

Ms. Fadeke Ayoola  
Independent Consultant/Ambassador  
107 Auckland Road, Potters Bar  
Hertfordshire, EN6 3HF  
UK

**Date of submission: 14 November 2015**

**Input to CDM-EB87-AA-A10**

**Re: Exploration for possible development of new methodologies and standardization of existing methodologies in food processing/storage and renewable energy for agriculture**

F.A.O. The Board of Directors,

As an ambassador for Farm Africa and an Independent Consultant, I am conducting research into renewal energy for the informal economy in the developing world. I have some recommendations with regard to the following two issues.

Food processing and/or food storage to reduce emissions in the agriculture sector:

(i) New methodology for mitigation actions in food processing and/or food storage;

Clean burning energy efficient stoves - an environmentally friendly technology to replace traditional inefficient cook stoves reduces air pollution in houses and improves the health condition of local people, as well as financial benefits. Clean burning energy also reduces the consumption of wood as fuel, which ultimately reduces the dependency on local forests, the mitigation of deforestation.

The materials used to build an energy efficient stove are simple to construct, cheap and locally sourced. Once trained the farmers can make or repair the stoves. Four main materials are used sand, clay, an iron rod, and chimney formulae. The sand and clay used to make bricks.

Research conducted recently in Tanzania by the FAO (2014), showed that 91% of villagers used wood as fuel. As a result, change in policy is required to enable renewable energy and address this issue.

Policy

- o To reduce dependency on the unsustainable use of fossil fuels and reduce GHG emissions, sustainable energy is required to feed the informal sector of the developing world.
- o The energy efficient stoves (EES) should become a policy instrument at governmental level across the developing world. Since according to the FAO, majority of the informal economy of developing countries require access to basic energy to alleviate energy poverty, and ensure a sustainable lifestyle, where cooking food, boiling drinking water is safe.

- o Stakeholder management is required to engage and provide capacity to local people.
- o Clean energy investment is required to enable adaptation to clean energy application.

(ii) Application of renewable energy for agriculture (e.g. solar-powered water pumps)

There are a number of renewable energy approaches for agriculture stated below to explore:

Bioenergy crops

Bio-energy crops are crops that are cultivated to provide biomass for conversion to liquid for transport and combined heat and power, crops such as corn, cassava, sugarcane, and rapeseed. For example, in Mauritius 40% of its total electricity supply is sourced from sugarcane. Once the sugar is extracted from the cane, the left over material is used for energy.

Biomass residues

Biomass is free, and is an alternative to using fossil fuels it takes the form of residue stalks, straw, leaves, roots, husk, nut or seed shells, and animal husbandry waste. According to UNEP, biomass residues left to rot or burn openly in the fields, especially in the developing world, can cause air pollution, posing risk to human and ecological health. Biomass is a renewable resource that causes problems when not used. Therefore, it is essential to convert the biomass into energy. Its use is carbon neutral and can displace the negative impacts of fossil fuels, helping to reduce GHG emissions.

Some examples of biomass waste used:

Crops Waste

Coconut - Fronds, husk, shell

Coffee - Hull, husk, ground

Corn - Cob, stover, stalks, leaves

Cotton - Stalks

Nuts - Hulls

Peanuts - Shells

Rice - Hull/husk, straw, stalks

Sugarcane - Bagasse

Agricultural Crops - Mixed agricultural crops, not limited to crop waste

Mixed type - Agricultural crops and waste including non-organic wastes

For further information, please see the report on the Global Assessment of Agricultural Biomass Waste Resources.

Policy recommendation

To develop a framework on waste biomass for developing countries, as a solution to the food and renewable energy nexus issue.

Enclosure: Report on the Global Assessment of Agricultural Biomass Waste  
Resources



# CONVERTING WASTE AGRICULTURAL BIOMASS INTO A RESOURCE

*Compendium of Technologies*

*Copyright © United Nations Environment Programme, 2009*

This publication may be reproduced in whole or in part and in any form for educational or non-profit purposes without special permission from the copyright holder, provided acknowledgement of the source is made. UNEP would appreciate receiving a copy of any publication that uses this publication as a source.

No use of this publication may be made for resale or for any other commercial purpose whatsoever without prior permission in writing from the United Nations Environment Programme.

**Disclaimer**

The designations employed and the presentation of the material in this publication do not imply the expression of any opinion whatsoever on the part of the United Nations Environment Programme concerning the legal status of any country, territory, city or area or of its authorities, or concerning delimitation of its frontiers or boundaries. Moreover, the views expressed do not necessarily represent the decision or the stated policy of the United Nations Environment Programme, nor does citing of trade names or commercial processes constitute endorsement.

# **Converting Waste Agricultural Biomass into a Resource**

## **Compendium of Technologies**

Compiled by



United Nations Environmental Programme  
Division of Technology, Industry and Economics  
International Environmental Technology Centre  
Osaka/Shiga, Japan

## Preface

Rapid increase in volume and types of waste agricultural biomass, as a result of intensive agriculture in the wake of population growth and improved living standards, is becoming a burgeoning problem as rotten waste agricultural biomass emits methane and leachate, and open burning by the farmers to clear the lands generate CO<sub>2</sub> and other local pollutants. Hence improper management of waste agricultural biomass is contributing towards climate change, water and soil contamination, and local air pollution. Furthermore, this waste is of high value with respect to material and energy recovery.

To manage waste agricultural biomass and to convert it into a material resource, considerable efforts are being made by many Governments and other entities, there are still major gaps to be filled, especially due to its “not in sight and not in mind” phenomenon. There is a lack of awareness and capacity to divert most of the waste for material and energy recovery. This would reduce the costs for waste disposal and would generate the revenue from the sale of the recovered materials and energy.

To raise the awareness and to build the capacity of local stakeholders, UNEP has started to promote **Integrated Solid Waste Management (ISWM) system based on 3R (reduce, reuse and recycle) principle**. This covers all the waste streams and all the stages of waste management chain, viz.: source segregation, collection and transportation, treatment and material/energy recovery and final disposal. It has been shown that with appropriate segregation and recycling system significant quantity of waste can be diverted from landfills and converted into resource.

Developing and implementing ISWM requires comprehensive data on present and anticipated waste situations, supportive policy frameworks, knowledge and capacity to develop plans/systems, proper use of environmentally sound technologies, and appropriate financial instruments to support its implementation.

Many national governments, therefore, have approached UNEP, [as reflected in the decision taken by the UNEP Governing Council/Global Ministerial Environment Forum during its 25<sup>th</sup> Session in February 2009 (**UNEP/GC.25/CW/L.3**)] to get further support for their national and local efforts in implementation of the Integrated Solid Waste Management (ISWM) programme.

In response to this decision and in line with the Bali Strategic Plan for Capacity Building and Technology Transfer, UNEP has developed a programme on integrated solid waste management. This programme includes support for capacity building and technology transfer for ISWM through a number of actions:

1. Guidelines to develop ISWM System: The four sets of guidelines on ISWM covering waste characterization and quantification, assessment of current waste management system, target

- setting and identification of stakeholders' issues of concern for ISWM, and how to develop ISWM Plan.
2. Pilot projects on ISWM and emerging waste streams including E-waste, waste agricultural biomass, waste plastics and so on
  3. Regional and sub-regional training for policy makers and experts on ISWM and emerging waste streams
  4. Interactive advisory support on ISWM and emerging waste streams

To raise the awareness and to build the local capacity for the designing and implementation of the projects on converting waste into material/resource source, UNEP has started compilation of compendium of technologies for various types of wastes.

This document is compilation of technologies which are in commercial use, under pilot implementation and under laboratory testing for converting waste agricultural biomass into material/energy source. This document is aimed to raise awareness on the available options vis-à-vis technologies as well as to assist the policy –makers and managers in the identification of appropriate technologies with respect to local economic, environmental, social and technical characteristics.

This document can also be of interest to other interested parties/organisations that aim at supporting decision-makers. They may be:

- consultants working on urban services, recycling, or waste management;
- representatives or staff of other local stakeholders including community groups, NGOs, and the private sector;
- entrepreneurs wishing to expand or strengthen their solid waste portfolios;
- academicians and scholars in urban environmental management;
- the press, especially when seeking background materials;
- donors interested in supporting future waste management activities;
- local experts interested in using or replicating the results.

This document and the information available at the website is compiled through best efforts with purpose of creating an information-base with periodic updates based on the feedback from technology experts, providers, suppliers and users. This document is not aimed to advertise or support any specific technology and errors and omissions are not intentional.



# Table of Contents

Preface	2
ACRONYMS	5
1. Introduction and Background	6
2. Rationale	7
3. Scope and Limitations	9
4. The Compendium	11
5. Conclusion	18
6. Recommendations	19
Annexure 1: EST for Energy Conversion - Commercial	20
Annexure 2: EST for Energy Conversion – Pilot	183
Annexure 3: EST for Energy Conversion - Research	228
Annexure 4: EST for Material Conversion – Commercial	264
Annexure 5: EST for Material Conversion – Pilot	392
Annexure 6: EST for Material Conversion - Research	414

## **ACRONYMS**

CO2	Carbon Dioxide
CV	Calorific Value
DAP	Development Academy of the Philippines
DTIE	Division of Technology, Industry and Economics
ESTs	Environmentally Sound Technologies
E-Waste	Electronic Waste
GDP	Gross Domestic Product
GHG	Greenhouse Gas
GIS	Geographic Information System
GPS	Global Positioning System
IETC	International Environmental Technology Centre
ISWM	Integrated Solid Waste Management
ISWMP	Integrated Solid Waste Management Plan
MBT	Mechanical and Biological Treatment
MC	Moisture Content
MRF	Materials Recovery Facility
MSW	Municipal Solid Waste
O&M	Operations and Maintenance
MEAs	Multilateral Environmental Agreements
3R	Reduce, Reuse and Recycle
SAT	Sustainability Assessment of Technologies
UNEP	United Nations Environment Programme
USD	The United States Dollar
WTE	Waste-to-Energy
WWTP	Wastewater Treatment Plant

## 1. Introduction and Background

Globally, 140 billion metric tons of biomass<sup>1</sup> is generated every year from agriculture. This volume of biomass can be converted to an enormous amount of energy and raw materials. Equivalent to approximately 50 billion tons of oil<sup>2</sup>, agricultural biomass waste converted to energy can substantially displace fossil fuel, reduce emissions of greenhouse gases and provide renewable energy to some 1.6 billion people in developing countries, which still lack access to electricity<sup>3</sup>. As raw materials, biomass wastes have attractive potentials for large-scale industries and community-level enterprises.

Biomass takes the form of residual stalks, straw, leaves, roots, husk, nut or seed shells, waste wood and animal husbandry waste. Widely available, renewable, and virtually free, waste biomass is an important resource.

With the global campaign to combat climate change, countries are now looking for alternative sources of energy to minimize green house gas (GHG) emissions. Aside from being carbon neutral, the use of biomass for energy reduces dependency on the consumption of fossil fuel; hence, contributing to energy security and climate change mitigation.

Although there is an emerging trend on the utilization of biomass conversion technologies -- from combustion of rice husk and sugarcane bagasse to gasification of other agricultural residues -- biomass is still largely under utilized and left to rot or openly burned in the fields, especially in developing countries that do not have strong regulatory instruments to control such pollutive practices. As a common practice, direct combustion of agricultural residue results in air pollution thereby posing risk to human and ecological health. Biomass is a renewable resource that causes problems when not used. The challenge, therefore, is to convert biomass as a resource for energy and other productive uses.

There are advantages in the use of biomass. Biomass is a renewable resource that has a steady and abundant supply, especially those biomass resources that are by-products of agricultural activity. Its use is carbon neutral, can displace fossil fuels, and helps reduce GHG emissions while closing the carbon cycle loop. As the debate on food versus fuel intensifies, biomass can provide added income to farmers without compromising the production of main food and even non-food crops.

---

<sup>1</sup> Biomass wastes include agricultural wastes, such as corn stalks, straw, sugarcane leavings, bagasse, nutshells, and manure from cattle, poultry, and hogs; forestry residues, such as wood chips, bark, sawdust, timber slash, and mill scrap; municipal waste, such as waste paper and yard clippings.

<sup>2</sup> Concept Paper, Using Agricultural Biomass Waste for Energy and Materials: Resource Conservation and GHG Emission Reduction, A Biomass Assessment and Compendium of Technologies Project, UNEP August 2007

<sup>3</sup> Annan calls for greater efforts to ensure access by poor to renewable energy, <http://www.un.org/apps/news/story.asp?NewsID=15483&Cr=development&Cr1=> August 19, 2005

## 2. Rationale

One of the critical activities of the United Nations Environment Program - Division of Technology, Industry and Economics - International Environmental Technology Center (UNEP-DTIE-IETC) is to promote sustainable consumption patterns. It also supports the Bali Strategic Plan for Capacity Building and Technology Support. Given these two thrusts, UNEP-DTIE-IETC conceptualized a project that would promote ecological solid waste management, reduction of greenhouse gases, maximum utilization of resources, and promote energy-efficient and environmentally-sound technologies.

Cognizant of the importance of converting waste biomass into a resource, UNEP-DTIE-IETC partnered with the Development Academy of the Philippines (DAP) in a project that would assess the global production and projection of waste biomass, compile data on existing biomass waste conversion technologies, evaluate these technologies based on the Sustainable Assessment of Technologies (SAT) Framework, develop a framework and conducive policy environment for the promotion of waste biomass use, and identify a site for a pilot demonstration project.

The main objectives of the project are to identify and assess environmentally-sound technologies for converting cellulosic biomass into energy and raw materials, and promote the use of biomass. Its outputs include a global assessment of biomass waste, development of a compendium of waste biomass conversion technologies, assessment of environmentally-sustainable technologies, selection of a project site for a demonstration project, and development of a policy framework for the increased use of waste biomass in a selected region in the Philippines. Overall, the project seeks to raise awareness on cellulosic biomass use globally, especially in developing countries, enable the implementation of such technologies to reduce GHG emissions from the use of fossil fuels, and augment material resources for a variety of products.

One of the major outputs of the project, the Compendium of Waste Biomass Conversion Technologies is an online resource site<sup>4</sup> of existing conversion systems and equipment utilizing agricultural residues, in commercial, pilot demonstration and research level of use. The Compendium is composed of the following parts:

Part I: Conversion of Waste Biomass to Energy

Part II: Conversion of Waste Biomass to Materials

The primary purpose of the Compendium is to respond to the information needs of decision-makers and end-users in selecting appropriate biomass

---

<sup>4</sup> Aside from the Compendium of Biomass Waste Conversion Technologies, the site also features other outputs of the UNEP-DAP Biomass Project such as a global assessment of biomass waste generation and projection, and data on the planned demonstration project.

waste conversion technologies given existing resources and local conditions. It was developed as a resource to provide access to real data and supplement guidance for sound judgment of project implementers.

By making the data on existing conversion technologies available on the internet, utilization of waste biomass is promoted globally. End-users in low income countries are also given equal access to available information. Ultimately, it is hoped that there will be a growing interest in biomass so that it would be seen no longer as waste but as a valuable resource. This interest could be translated into actual utilization of waste biomass especially in areas where it is most needed.

### 3. Scope and Limitations

In compiling the data for the Compendium, the primary methodology used is data gathering and review of published and online documents on waste biomass conversion technologies. Data from these documents are then organized into fact sheets, which include a summary of technology information, details of the biomass conversion process, and the equipment used<sup>5</sup>.

Technologies listed in the Compendium are limited to those that use cellulosic<sup>6</sup> agricultural waste biomass. Technologies using exclusively non-waste biomass, such as energy crops like poplars, willows, switchgrass, alfalfa, prairie bluestem, corn, soybean oil and others, are excluded from the Compendium. It also leaves out technologies using animal husbandry waste. However, some technologies included in the Compendium utilize a mix of biomass resources consisting of agricultural residues, energy crops, animal waste and even some inorganic materials such as those found in municipal solid wastes.

Part I compiles technologies that convert agricultural biomass waste into energy products such as heat and steam, electricity, producer gas, synthetic fuel oil, charcoal, methane, ethanol, bio-diesel and methanol. Part II lists down the technologies that convert agricultural biomass waste into raw materials or non-energy products such as cordage, textiles, paper products, upholstery and packaging materials, animal feed, insulators and panel boards, among many others. Each technology datasheet in the Compendium is coupled with a technology assessment sheet<sup>7</sup> to enable users to decide if the technology is applicable to their needs.

The geographical scope of the compendium is global. Thus, technologies listed range from highly sophisticated equipment from industrialized countries to simple technologies from the developing countries. Different levels of use are also considered, i.e., commercial use, demonstration projects, and research level technologies.

Data gathering was conducted from the September 2007 to May 2008. However, publication date is not a criterion for technology inclusion in the Compendium because the information gathered range from current to as old as five years, as available on the web and other publications. Moreover, a technology or equipment's inclusion in the Compendium does not constitute an endorsement of any kind by UNEP. Rather, it merely provides access to information needed by end users such as farmer groups, non-government organizations, local government units and industry.

---

<sup>5</sup> For details, see Part IV: The Compendium

<sup>6</sup> Cellulosic biomass is composed of cellulose, hemicellulose and lignin, with smaller amounts of proteins, lipids and ash. Examples of cellulosic biomass wastes are rice hull and stalks, coconut coir and shell.

<sup>7</sup> See annexes for sample of technology datasheet and accompanying assessment sheet

One limitation of the Compendium is insufficiency of data available on existing technologies. This is because online and printed resources do not include all data required in each technology data sheet in the Compendium. Consequently, not all data fields are filled with complete information, which pose a challenge to technology assessment. The online Compendium alone is not enough to meet the growing requirement for current data in the field of waste biomass utilization. To help address this concern, users who wish to get further information on any of the technologies are advised to communicate with suppliers or technology developers whose contact information are provided in the datasheets. They can also visit the website of suppliers which are updated more often. The URLs are provided in the footnotes of the datasheets.

## 4. The Compendium

### The Project Website

The Compendium of Waste Biomass Conversion Technologies is part of the website developed for the Project entitled “Using Agricultural Biomass Waste for Energy and Materials, Resource Conservation and GHG Reduction”. It can be accessed in the URL [http://cshd.dap.edu.ph/unep\\_biomass/](http://cshd.dap.edu.ph/unep_biomass/). The site shows three major project outputs:

- I. Global Assessment on Cellulosic Waste Biomass
- II. Compendium of Waste Biomass Conversion Technologies
- III. Other Documents

Under the Compendium are two links leading to conversion technologies, first for energy, and second for materials<sup>8</sup>. The point of reference for users is the crop type and the agricultural waste. From here the user can see the different conversion processes and the technologies under these processes. The technology then provides a link to the PDF files of the technology datasheet and technology assessment. It is so arranged so that end users facing solid waste management issues can immediately access information on technologies that utilize the kind of waste that they have or generate. And even before the users click on the link to the datasheet, they can already see what sort of product the conversion process generates.

Completed with the users’ needs in mind, the Compendium features the information materials presented below.

### A. Technology Data Sheets

- Crop – agricultural crop that generates the biomass waste
- Residue –waste biomass resulting from harvesting the primary crop, in the technology datasheet, it refers to the main raw material for conversion
- Auxiliary Materials- materials, which may or may not be biomass waste, added to the main raw material for processing
- Process- the biomass conversion procedure, such as combustion, gasification, densification, among others
- Equipment- machine/s used in the conversion process
- Main Products- result of waste biomass conversion, for energy, refers to fuel, heat or electricity, and for materials, whatever product resulting to the conversion process
- By Products- value added products to main product

---

<sup>8</sup> Website interface are placed in the annexes.



- Production capacity- refers to the capacity of the equipment to produce a certain amount of energy and non-energy products
- Technical Description of Technology- includes the detailed process description
- Job Potential- the number and nature of jobs that will be generated by technology application
- Parameters for Procurement Specifications- Considerations such as land area required, dimensions of the equipment and other details regarding purchase of equipment
- Operation and Maintenance Requirements- Personnel, technical and other factors necessary for the efficient operation and maintenance of the equipment
- Investment and Operating Cost- Financial considerations in procurement, installation and operation of the system or machinery
- Environmental Considerations- advantages and disadvantages for the environment
- Social Considerations- potential issues and concerns that may arise in the communities where the technology will be applied
- Specific Considerations for developing countries- advantages and/or disadvantages for developing countries
- Institutional and Regulatory Consideration or Requirements- Compliance to international or local regulatory standards
- Process Description- details of the conversion process, whenever available, from collection of raw materials to the conversion process down to the end use
- Price of Machine- cost of the equipment, including transport cost if to be imported
- GHG Emission Reduction Potential- a computation of GHG savings incurred by displacing the use of fossil fuels through use of the biomass conversion technology
- Examples of Real-life Applications- cites location of actual use of technology and level of use, whether commercial, pilot demonstration or research
- Supplier- name and contact information of equipment manufacturer or developer
- Justification/Profitability Indicator- Return of investment and payback period
- Illustrations/graphs/photographs
- Information sources

## **B. Technology Assessment Sheets**

Technology Assessment Sheets accompany each Technology Data Sheet to enable the end users to screen the technologies applicable to local implementation. Assessments include the following information:

- Basic technology information<sup>9</sup> such as those in the technology data sheets, including crop, residue, process, equipment, main product and by-product;
- Technical component- input and output capacity, equipment/s needed in the conversion process and efficiency of equipment;
- Environmental Component- pollution disposal and control, fossil fuel displacement, compliance to regulatory standards, among others;
- Social Component- potential hazard to community, local acceptability, job generation and other benefits;
- Economic Viability- capital outlay and return of investment, loans and subsidies and incentives, and
- Possible Barriers to Developing Countries- insufficient capability to operate machinery, lack of fiscal incentives to project holders, need for policy measures, among others

## Summary of Technology Entries

### A. Waste Biomass Resources

For a comprehensive global assessment of waste biomass resources, including waste biomass generation and projection, as well as potential use and equivalent GHG reduction, please see the Report on the Global Assessment of Agricultural Biomass Waste Resources.

The major crops and waste utilized in the Compendium's technology entries are the following:

<b>Crop</b>	<b>Waste</b>
▪ <b>Coconut</b>	- Fronds, husk, shell
▪ <b>Coffee</b>	- Hull, husk, ground
▪ <b>Corn</b>	- Cob, stover, stalks, leaves
▪ <b>Cotton</b>	- stalks
▪ <b>Nuts</b>	- Hulls
▪ <b>Peanuts</b>	- Shells
▪ <b>Rice</b>	- Hull/husk, straw, stalks
▪ <b>Sugarcane</b>	- Bagasse
▪ <b>Agricultural Crops</b>	- Mixed agricultural crops, not limited to crop waste
▪ <b>Mixed type</b>	- Agricultural crops and waste including non-organic wastes

---

<sup>9</sup> The same information is provided in the assessment to make it user-friendly.

## B. Major Waste Biomass Conversion Routes:

Acharya, on the initiatives of ADB on using waste biomass<sup>10</sup>, presented major waste biomass conversion routes to energy in a flowchart. Based on Acharya's Biomass Conversion Routes, the following flowchart was designed to include conversion technologies applicable only to agricultural biomass wastes. The flowchart, which does not include routes for energy crops and animal husbandry wastes, summarizes the entries on technology conversion for energy in the Compendium. Mapping out conversion processes down to energy products, the flowchart provides a useful guide to end-users on which technology to consider given their energy product requirement.

**Chart I: Conversion Routes for Cellulosic Agricultural Biomass Waste**

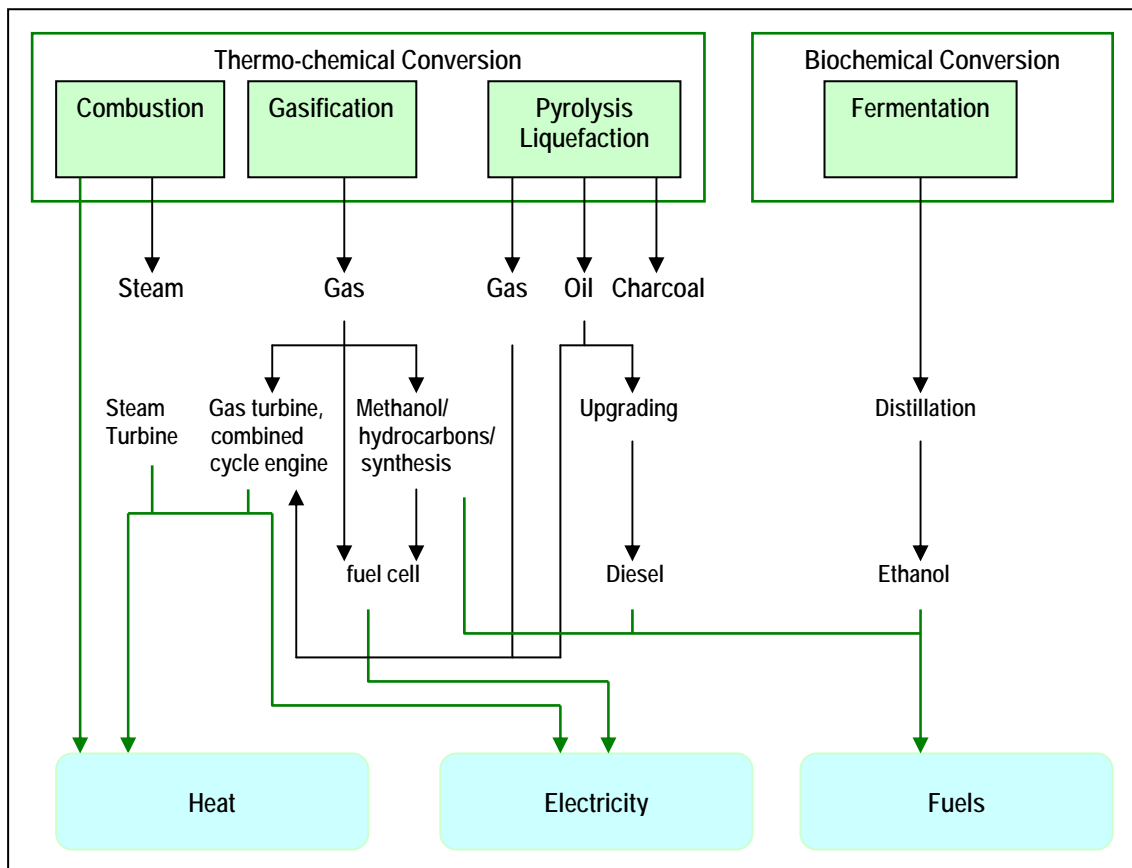

## C. Conversion to energy

Expanding the conversion routes to include the kind of biomass waste and the specific energy product generated, Table 1 is produced to sum up entries for Part I of the Compendium.

<sup>10</sup> ADB's Initiatives on Using Waste Biomass: Agricultural Waste Utilization Project in PRC, presented during the UNEP-DAP International Expert Group Workshop on Compendium of EST for Converting Waste Biomass into a Resource on Nov.13-14, 2007, at the Astoria Plaza, Pasig City, Philippines by Mr. Jiwan Acharya, of the Energy, Transport, and Water Division of the Asian Development Bank

**Table 1: Cellulosic Waste Biomass Conversion to Energy**

Technology	Conversion Process Type	Biomass Waste	Energy or Fuel Produced
<b>Biodiesel Production</b>	Chemical	rapeseed soy beans waste vegetable oil	biodiesel
<b>Direct Combustion</b>	Thermochemical	agricultural waste mixed waste	heat steam electricity
<b>Ethanol Production</b>	Biochemical (aerobic)	sugar or starch crops wood waste pulp sludge rice and corn straw	ethanol
<b>Gasification</b>	Thermochemical	agricultural waste mixed waste	low or medium-Btu producer gas
<b>Methanol Production</b>	Thermochemical	agricultural waste mixed waste	methanol
<b>Pyrolysis</b>	Thermochemical	agricultural waste municipal solid waste	synthetic fuel oil (biocrude) charcoal

**Chart 2: Level of Use for Energy Conversion**

		Household energy Briquetting Carbonization Combustion
Bio-chemicals	Bio-oil applications Gasification Pyrolysis	
Research	Pilot Demonstration	Commercial

Chart 2 shows the level of use of the different conversion technologies for energy. Household energy, mainly for cooking, heating and drying, are the most widely available technologies. Biomass cook stoves, for instance, have hundreds of versions all around the world. Those documented in the

Compendium shows existing samples in the Southeast Asia. Gasification and Pyrolysis have most technologies in the demonstration stage. These technologies are concentrated in Europe, USA, Japan and India. Bio-oil and bio-chemical applications are mostly in the research and development stage and are distributed in Europe, North America and Japan.

#### D. Conversion to materials

Table 2 shows the major conversion technologies for converting biomass waste to materials and their products. It summarizes entries in Part II of the Compendium. The table illustrates the great potential of waste biomass for conversion to a variety of materials.

**Table 2: Cellulosic Biomass Waste Conversion to Materials**

Conversion Process	Biomass Waste	Product
Bio-reduction	Pineapple leaves Sugarcane residues	Animal feed, industrial absorbents and additives for beverages
	Wheat straw Cotton gin	Wheat straw polypropylene Pelletized feedstock, fertilizer
Bio-refinery system	Rice husk	Silica, Metal Finishing, Water Soluble Oil & Synthetic Lubricant
	Sugarcane bagasse Wheat straw	Lumber materials Panel boards
Decortication	Abaca Leaves	Fiber craft, cordage, textile and fabrics, pulp, and specialty papers,
	Coconut husk	Coconut fiber Rope and twine, brooms and brushes, doormats, rugs, mattresses and upholstery, often in rubberized coir pads
	Pina leaves	Elegant pina cloth
Hot melt process	Kenaf Fibers, Sugarcane bagasse	Paper and packaging materials
Hydro-separation	Sugar mill boiler ash from bagasse	Filtration materials and absorbent products

Molding	Oil Palm fruit residues Sugarcane bagasse	Biodegradable packaging materials Paper and paper wares
Pulping	Kenaf Fibers	Soundproofing systems, thermal insulators
Tuxying	Abaca leaves	Abaca leaf sheath
Twining	Coconut Coir	Coconut twines

Chart 3 shows the level of use for biomass conversion to materials. It shows age-old conversion processes such as twining, decortication and tuxying as the most improved and commercially available technologies. However, it also shows that there is a growing trend in utilizing waste biomass for packaging and even as additive to building materials. Bio-refinery processes and reduction are mostly in research and development stage.

**Chart 3: Level of Use for Material Conversion**

Bio-refinery Bio-reduction	Molding Hot melt process Hydro-separation	Twining Decortication Tuxying Pulping
Research	Pilot Demonstration	Commercial

## 5. Conclusion

The Compendium does not claim to be a definitive collection of all existing cellulosic biomass technologies in the world. Although the scope of the Compendium is global, most of the technologies included therein are developed and being used in the USA, Canada, Europe, India and Southeast Asia. It is notable that there is no technology in the Compendium from the Middle East and only a handful come from Africa.

In Africa and other developing regions, dependence on biomass for household needs, such as cooking and drying food or community-level enterprise use, are known to exist but not extensively documented. The Compendium is only limited to data available on the net or in English publications. Another factor is that information on many research and pilot-level demonstration technologies are not yet available on the Internet or in other publications. The challenge now is how to ensure that the Compendium best captures technology available worldwide, especially those existing in developing countries, so that those who need it more can have the ease of access to information on these technologies.

The usability of the Compendium of Biomass Waste Conversion Technologies was tested with the selection of appropriate technologies for a proposed pilot project to be implemented in a selected region the Philippines. Based on the process undergone by the selection of technologies, the Sustainability Assessment of Technologies (SAT), a tool developed by UNEP, the Compendium proves valuable in screening, scoping and selecting technologies appropriate for project implementation<sup>11</sup>. Through the technology data sheets, the Compendium provided useful data needed to be able to select the appropriate technology for the pilot site.

However, given that some technologies have incomplete data fields, there is a need to intensify and deepen research on the growing number of technologies. Periodic updating and upgrading the Compendium is therefore imperative if it is to be continuously relevant in the future.

---

<sup>11</sup> See Report on Sustainable Assessment of Technologies for UNEP-DAP Biomass Waste Conversion Pilot Project in Nueva Ecija, Philippines.

## 6. Recommendations

The specific recommendations to improve the Compendium are as follows:

- Convert the existing html-based Compendium in the current website into a database type of content management system to enable ease of access and update of information, or better yet, allow posting of additional data by technology suppliers, users and developers using info-share approach;
- Conduct a wide-ranging public information and communication campaign to popularize the Compendium, especially in developing countries that would best benefit from its use, and
- Include a user-friendly version of SAT in the website so that those who access information on biomass waste conversion technologies will also be able to compare their efficiency and assess their applicability given their local condition and available cellulosic biomass.



## **Details of Technologies**

### **1. Waste to Energy Conversion**

#### **A. Technologies in Commercial Use**

**2-Drum Top Supported Boiler<sup>12</sup>**  
**USA, Commercial**

<b>Crop</b>	Sugar, coconut, coffee, corn, peanut, rice, switchgrass
<b>Residue</b>	Bagasse, coconut hulls, coffee grounds, corn cobs, peanut hulls, rice husks, switchgrass
<b>Process</b>	Combustion
<b>Equipment</b>	2-Drum Top Supported Boiler
<b>Main Products</b>	Heat and Steam

**Technical Description of Technology**

<b>2-Drum Bottom Supported Boiler Design Parameters</b>	
<b>•Steam capacities</b>	40,000 LB/hr to 200, 000 lb/hr (18 t/hr to 82 t/hr)
<b>•Maximum design pressure</b>	1200 psig (82 bar)
<b>•Maximum steam temperature</b>	900°F(482°C)
<b>•Furnace construction</b>	Tube & tile or membrane wall

**M2 Gasification Technology<sup>13</sup>**  
**USA, Commercial**

<b>Crop</b>	Sugarcane, forest
<b>Residue</b>	Tar sands, cane stock, forestry, pulp or paper waste
<b>Process</b>	Gasification
<b>Equipment</b>	M2 Gasifier
<b>Main Product</b>	Syngas

<sup>12</sup> <http://www.mcburney.com/biomass.htm#mod>

<sup>13</sup> <http://www.syngasinternational.com/technology.html>

## Technical Description of Technology

The M2 uses gasification processes to convert any carbon based material into a synthetic gas. Gasification uses heat and pressure which converts any carbon containing materials into synthetic gas composed primarily of carbon monoxide and hydrogen which has a large number of uses. Gasification adds value to low or negative value feedstock's by converting them to marketable fuels. The feed stocks used to create syngas depends on what's readily available. Cheap low grade coal is a readily available supply. In Alberta, Tar Sands provide an abundant fuel source. An application in India under consideration utilizes cane stock from farming waste. Urban applications include garbage and tires. Throughout North America, forestry, pulp and paper waste can be used to be recycled into syngas and fed back into power plants. Various other industrial wastes can be fed back into plants to recycle "lost energy", that would otherwise go to landfills.

According to the US department of energy, gasification may be one of the best ways to produce clean-burning hydrogen for tomorrow's automobiles and power generating fuel cells. Hydrogen and other coal gases can also be used to fuel power generating turbines or as the chemical "building blocks" for a wide range of commercial products.

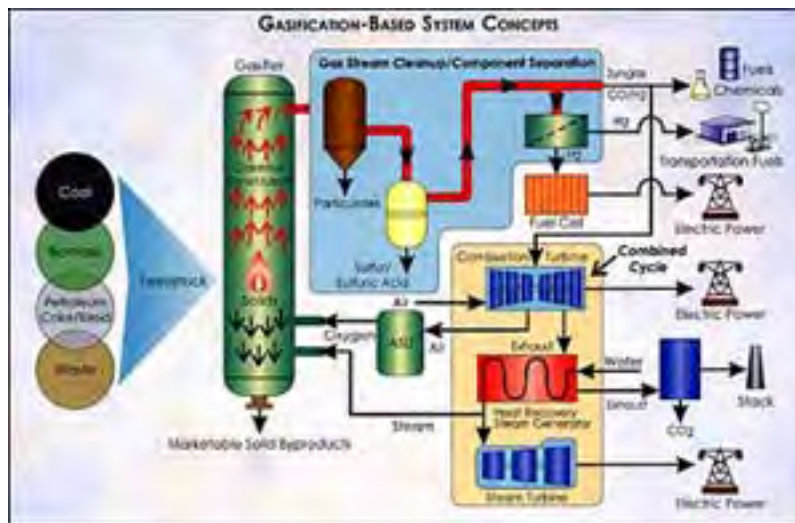

DOE IGCC Concept

### Supplier

Telephone: **1.702.568.4131**

Toll Free: **1.877.568.4137**

Fax: **1.702.366.0002**

### Energy Quest, Inc.

850 South Boulder Hwy, Suite 169

Henderson, Nevada, USA 89015 – 4131

Sales and Marketing : [info@nrqgst.com](mailto:info@nrqgst.com)

## HYBRID PF<sup>14</sup> USA, Commercial

<b>Crop</b>	Agricultural materials
<b>Residue</b>	Agricultural residue
<b>Process</b>	Gasification, combustion
<b>Equipment</b>	Boiler Hybrid PF
<b>Main Product</b>	High pressure steam or hot water

### Production Capacity

The Hybrid PF design is suitable for applications to produce high pressure steam or hot water in ranges from 3,450 - 60,000 lbs/hr (3.4 mm BTU - 60 mm BTU) output from 100 up to 400 PSI.



<sup>14</sup> <http://www.hurstboiler.com/biomass.html>

## Detailed Process Description

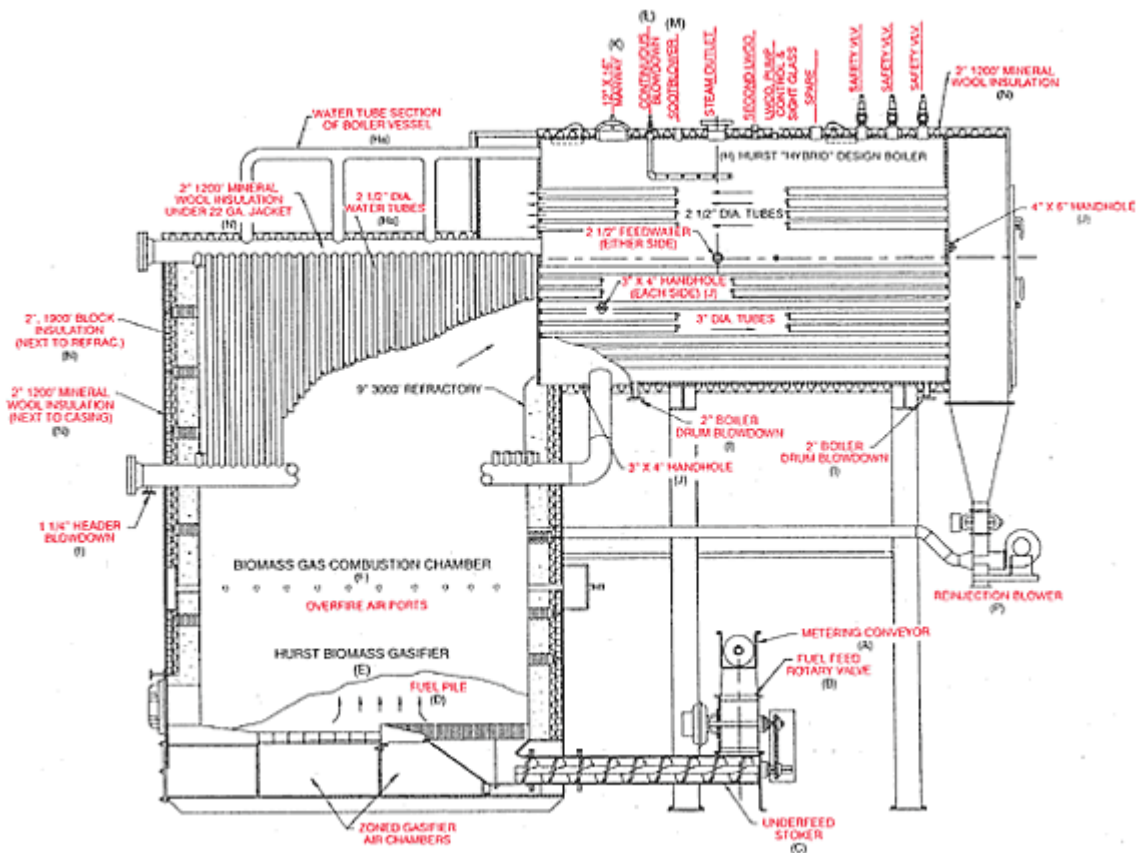

### A. Metering Conveyor

Extra Heavy Duty Screw Conveyor with Variable Frequency AC Drive

### B. Rotary Air Lock Valve

Limits Excess Air for Improved Combustion Control, Increased Efficiency and Emission Control

### C. "Frederick" Solid Fuel Stoker

Manufactured since 1918, it is unsurpassed in the dependable stoking of solid fuels

### D. Fuel Pile

The fuel pile, maintained by the stoker, covers all the grates for Improved Combustion Efficiency and Emission Control.

### E. Gasifier

A combination of the "Frederick" stoker, combustion air system, and lower combustion chamber. The Hurst "Gasifier" vaporizes the volatile gasses from the solid fuel, driven by the remaining carbon on the grates.

### F. Combustion Chamber

Combustion Air is mixed with the volatile gas created by the gasifier and burned in this area of the furnace.

### G. Combustion Air System

Two blowers, one under fire and one over fire, furnishes and controls the volume of air entering the Gasifier and Combustion Chamber. All above work in concert to reduce solid fuels into usable heat energy utilizing the most reliable system yet devised. Our "cruise control" system orchestrates the

operation of each to match the steam load and maintain efficient combustion. All above work in concert to reduce solid fuels into usable heat energy utilizing the most reliable system yet devised. Our "cruise control" system orchestrates the operation of each to match the steam load and maintain efficient combustion.

#### **H. "Hybrid" Design Boiler**

Originally built in Germany, the "Hybrid" design is unequalled in the heat recovery from solid fuels.

##### **Ha. Water Tube Section**

The watertube section of the "Hybrid" boiler allows for abundant radiant heating surface. This allows for quicker recovery and more efficient heat transfer than in the typical firetube boiler.

##### **Hb. Fire Tube Section**

The fire tube section of the "Hybrid" boiler allows for greater water volume and thermal reserve than the typical water tube boiler. Quick response with the additional capacity to handle spike loads is the result. In addition, the two pass design increases gas velocity and efficiency and a cleaner boiler result.

##### **Hc. Steam Space**

The fire tube section of the "Hybrid" also allows for several times the steam space of a typical boiler. The larger steamrelease surface is calmer, reducing carry over of unevaporated water. The resulting drier steam also reduces system scaling. In addition, dry steam helps eliminate unnecessary extra condensate. Energy and fuel are saved.

#### **I. Boiler Blowdown**

##### **J. Handhole**

The waterside openings are located in the most effective positions. The lower hand holes offer far better access for both clean out and inspection.

##### **K. Manway**

##### **L. Continuous Blowdown**

##### **M. Soot Blower**

Fixed zone

##### **N. Insulation And Jacketing**

2' High Density fiberglass insulation and 22 ga. zinc coated metal jacket.

##### **O. Rear Smoke Box**

Liberal and easy accessible gas turn around area. No large refractory doors or wet back to work around.

##### **P. Reinjection Blower**

Continuously cleans rear smoke box.

##### **Q. Skids and Support Structure**

Unit is skid mounted with rear supports for easy handling and set-up.

#### **Operation and Maintenance Requirements**

1. Ash removal is a manual operation.
2. The company stocks replacement parts for the boilers and other major competitors' boilers as well. Manufacturing facility is in Coolidge, GA, supports parts center with the latest technology and competitive rates, offering shipping with Emory, DHL, Fed Ex and "UPS On Line Shipping / Tracking" for speedy delivery of critical parts orders to any facility in a timely fashion.

**Examples of Real Life Applications**

Commercial use    Hybrid PF    Highway 319 N. Coolidge, GA 31738

**Supplier**

Hurst Boiler and Welding Co., Inc.

## HYBRID RG<sup>15</sup> USA, Commercial

<b>Crop</b>	Agricultural materials
<b>Residue</b>	Agricultural residue
<b>Process</b>	Gasification, combustion
<b>Equipment</b>	Boiler Hybrid RG
<b>Main Product</b>	high pressure steam or hot water

### Production Capacity

The Hybrid RG design is suitable for applications to produce high pressure steam or hot water in ranges from 3,450 - 60,000 lbs/hr (3.4 mm BTU - 60 mm BTU) output from 100 up to 400 PSI.

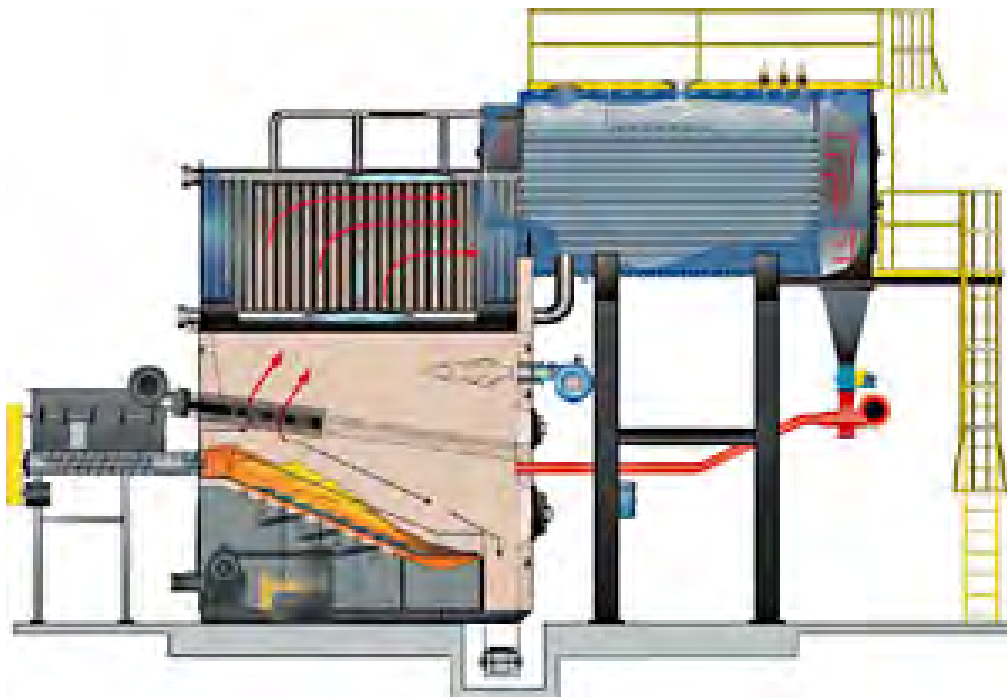

<sup>15</sup> <http://www.hurstboiler.com/biomass.htm>



## Detailed Process Description

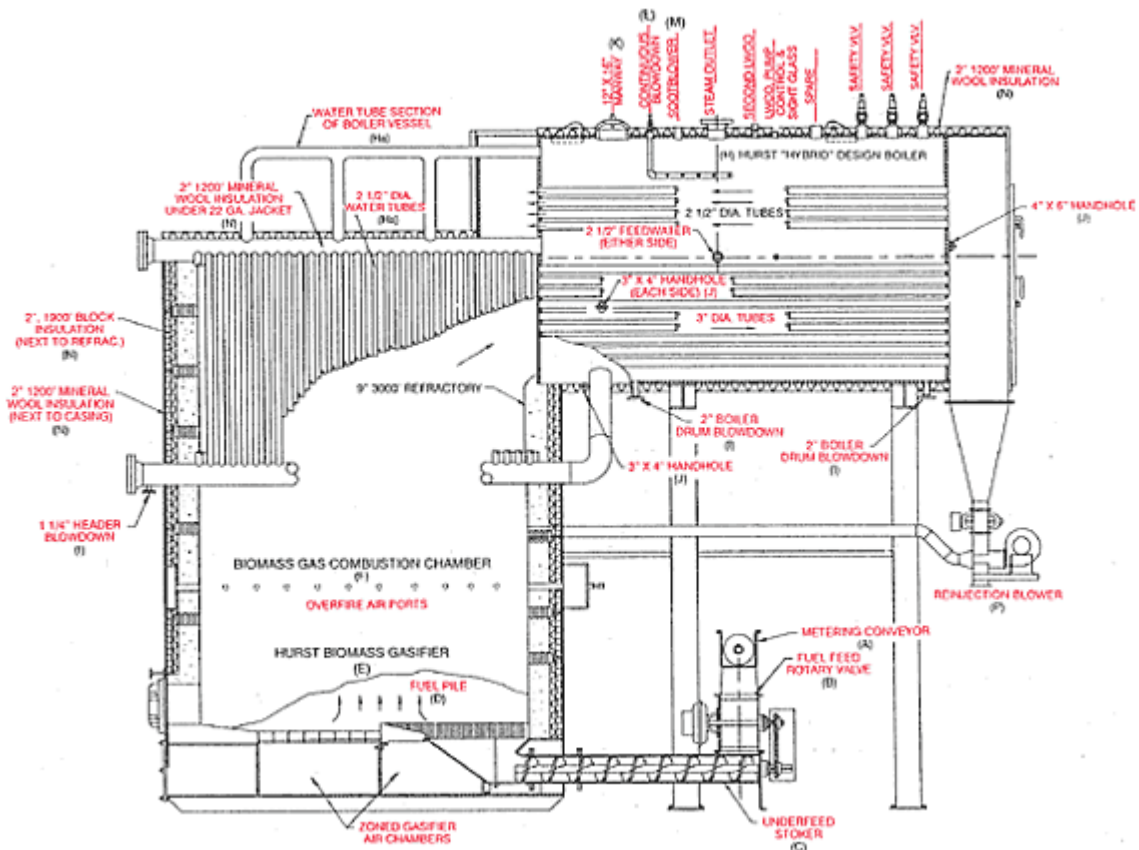

### A. Metering Conveyor

Extra Heavy Duty Screw Conveyor with Variable Frequency AC Drive

### B. Rotary Air Lock Valve

Limits Excess Air for Improved Combustion Control, Increased Efficiency and Emission Control

### C. "Frederick" Solid Fuel Stoker

Manufactured since 1918, it is unsurpassed in the dependable stoking of solid fuels

### D. Fuel Pile

The fuel pile, maintained by the stoker, covers all the grates for Improved Combustion Efficiency and Emission Control.

### E. Gasifier

A combination of the "Frederick" stoker, combustion air system, and lower combustion chamber. The Hurst "Gasifier" vaporizes the volatile gasses from the solid fuel, driven by the remaining carbon on the grates.

### F. Combustion Chamber

Combustion Air is mixed with the volatile gas created by the gasifier and burned in this area of the furnace.

### G. Combustion Air System

Two blowers, one under fire and one over fire, furnishes and controls the volume of air entering the Gasifier and Combustion Chamber. All above work in concert to reduce solid fuels into usable heat energy utilizing the most reliable system yet devised. Our "cruise control" system orchestrates the operation of each to match the steam load and maintain efficient combustion.

All above work in concert to reduce solid fuels into usable heat energy utilizing the most reliable system yet devised. Our “cruise control” system orchestrates the operation of each to match the steam load and maintain efficient combustion.

#### **H. “Hybrid” Design Boiler**

Originally built in Germany, the “Hybrid” design is unequalled in the heat recovery from solid fuels.

##### **Ha. Water Tube Section**

The watertube section of the “Hybrid” boiler allows for abundant radiant heating surface. This allows for quicker recovery and more efficient heat transfer than in the typical firetube boiler.

##### **Hb. Fire Tube Section**

The fire tube section of the “Hybrid” boiler allows for greater water volume and thermal reserve than the typical water tube boiler. Quick response with the additional capacity to handle spike loads is the result. In addition, the two pass design increases gas velocity and efficiency and a cleaner boiler result.

##### **Hc. Steam Space**

The fire tube section of the “Hybrid” also allows for several times the steam space of a typical boiler. The larger steamrelease surface is calmer, reducing carry over of unevaporated water. The resulting drier steam also reduces system scaling. In addition, dry steam helps eliminate unnecessary extra condensate. Energy and fuel are saved.

#### **I. Boiler Blowdown**

##### **J. Handhole**

The waterside openings are located in the most effective positions. The lower hand holes offer far better access for both clean out and inspection.

##### **K. Manway**

##### **L. Continuous Blowdown**

##### **M. Soot Blower**

Fixed zone

##### **N. Insulation And Jacketing**

2' High Density fiberglass insulation and 22 ga. zinc coated metal jacket.

##### **O. Rear Smoke Box**

Liberal and easy accessible gas turn around area. No large refractory doors or wet back to work around.

##### **P. Reinjection Blower**

Continuously cleans rear smoke box.

#### **Q. Skids and Support Structure**

Unit is skid mounted with rear supports for easy handling and set-up.

#### **Operation and Maintenance Requirements**

1. The new HBC chain grate-type stoker system permits a wide range of biomass fuels with high ash contents to be combusted in an efficient manner with the added advantage of automatic de-ashing.
2. The company stocks replacement parts for the boilers and other major competitors' boilers as well. Manufacturing facility is in Coolidge, GA, supports parts center with the latest technology and competitive rates, offering shipping with Emory, DHL, Fed Ex and "UPS On Line Shipping

/ Tracking" for speedy delivery of critical parts orders to any facility in a timely fashion.

**Example of Real Life Applications**

Commercial use    Hybrid RG    Highway 319 N. Coolidge, GA 31738

**Suppliers**

Hurst Boiler and Welding Co., Inc.

## HYBRID UF<sup>16</sup> USA, Commercial

<b>Crop</b>	Agricultural materials
<b>Residue</b>	Agricultural residue
<b>Process</b>	Gasification, combustion
<b>Equipment</b>	Boiler Hybrid UF
<b>Main Product</b>	High pressure steam or hot water

### Technical Description of Technology



### Production Capacity

The Hybrid PF design is suitable for applications to produce high pressure steam or hot water in ranges from 3,450 - 60,000 lbs/hr (3.4 mm BTU - 60 mm BTU) output from 100 up to 400 PSI.

---

<sup>16</sup> <http://www.hurstboiler.com/biomass.html>

## Detailed Process Description

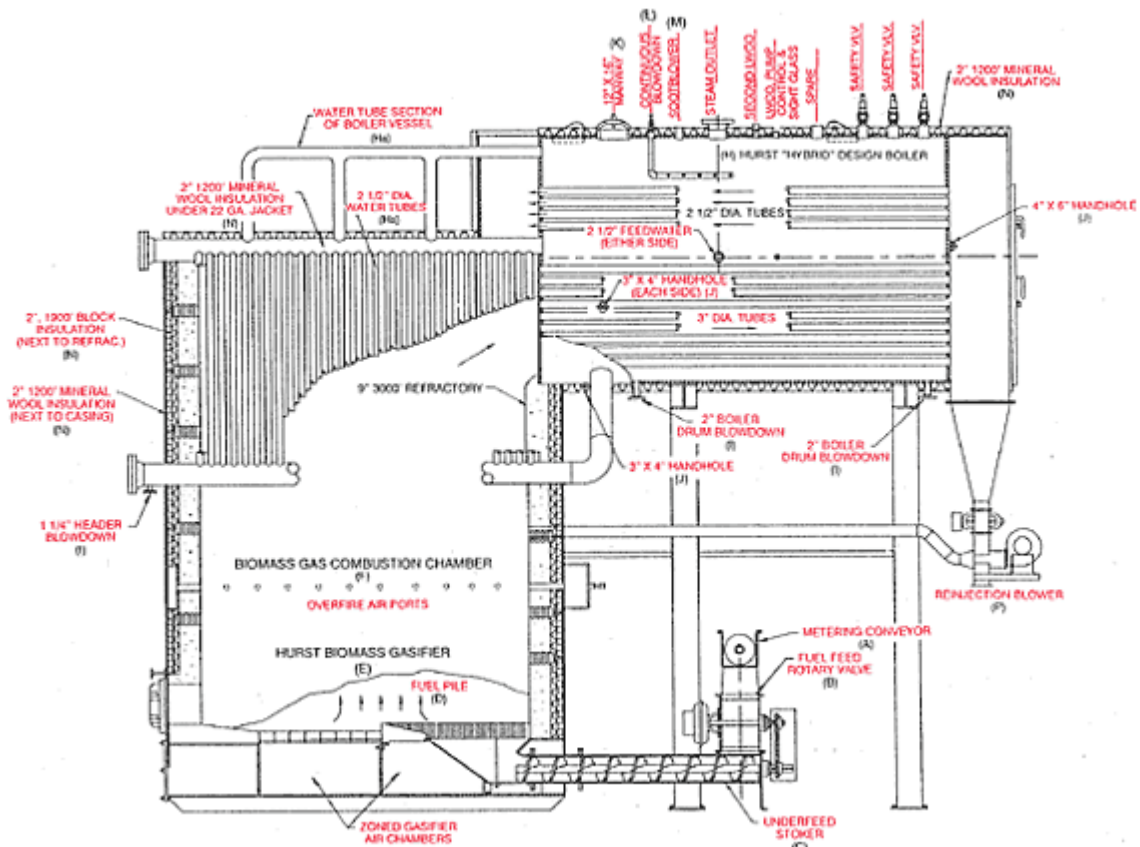

### A. Metering Conveyor

Extra Heavy Duty Screw Conveyor with Variable Frequency AC Drive

### B. Rotary Air Lock Valve

Limits Excess Air for Improved Combustion Control, Increased Efficiency and Emission Control

### C. "Frederick" Solid Fuel Stoker

Manufactured since 1918, it is unsurpassed in the dependable stoking of solid fuels

### D. Fuel Pile

The fuel pile, maintained by the stoker, covers all the grates for Improved Combustion Efficiency and Emission Control.

### E. Gasifier

A combination of the "Frederick" stoker, combustion air system, and lower combustion chamber. The Hurst "Gasifier" vaporizes the volatile gasses from the solid fuel, driven by the remaining carbon on the grates.

**F. Combustion Chamber** Combustion Air is mixed with the volatile gas created by the gasifier and burned in this area of the furnace.

### G. Combustion Air System

Two blowers, one under fire and one over fire, furnishes and controls the volume of air entering the Gasifier and Combustion Chamber. All above work in concert to reduce solid fuels into usable heat energy utilizing the most reliable system yet devised. Our "cruise control" system orchestrates the

operation of each to match the steam load and maintain efficient combustion. All above work in concert to reduce solid fuels into usable heat energy utilizing the most reliable system yet devised. Our "cruise control" system orchestrates the operation of each to match the steam load and maintain efficient combustion.

#### **H. "Hybrid" Design Boiler**

Originally built in Germany, the "Hybrid" design is unequalled in the heat recovery from solid fuels.

##### **Ha. Water Tube Section**

The watertube section of the "Hybrid" boiler allows for abundant radiant heating surface. This allows for quicker recovery and more efficient heat transfer than in the typical firetube boiler.

##### **Hb. Fire Tube Section**

The fire tube section of the "Hybrid" boiler allows for greater water volume and thermal reserve than the typical water tube boiler. Quick response with the additional capacity to handle spike loads is the result. In addition, the two pass design increases gas velocity and efficiency and a cleaner boiler result.

##### **Hc. Steam Space**

The fire tube section of the "Hybrid" also allows for several times the steam space of a typical boiler. The larger steam release surface is calmer, reducing carry over of unevaporated water. The resulting drier steam also reduces system scaling. In addition, dry steam helps eliminate unnecessary extra condensate. Energy and fuel are saved.

#### **I. Boiler Blowdown**

##### **J. Handhole**

The waterside openings are located in the most effective positions. The lower hand holes offer far better access for both clean out and inspection.

##### **K. Manway**

##### **L. Continuous Blowdown**

##### **M. Soot Blower**

Fixed zone

##### **N. Insulation And Jacketing**

2' High Density fiberglass insulation and 22 ga. zinc coated metal jacket.

##### **O. Rear Smoke Box**

Liberal and easy accessible gas turn around area. No large refractory doors or wet back to work around.

##### **P. Reinjection Blower**

Continuously cleans rear smoke box.

##### **Q. Skids and Support Structure**

Unit is skid mounted with rear supports for easy handling and set-up.

#### **Operation and Maintenance Requirements**

3. Ash removal is a manual operation.
4. The company stocks replacement parts for the boilers and other major competitors' boilers as well. Manufacturing facility is in Coolidge, GA, supports parts center with the latest technology and competitive rates, offering shipping with Emory, DHL, Fed Ex and "UPS On Line Shipping / Tracking" for speedy delivery of critical parts orders to any facility in a timely fashion

**Example of Real Life Applications**

Commercial Use    Hybrid UF    Highway 319 N. Coolidge, GA 31738

**Supplier**

Hurst Boiler and Welding Co., Inc.  
Highway 319 N. Coolidge, GA 31738

**TRI<sup>17</sup>**  
**USA, Commercial**

<b>Crop</b>	A wide variety renewable organic feedstock
<b>Residue</b>	Agricultural residue
<b>Process</b>	Gasification
<b>Equipment</b>	Gasifier
<b>Main Product</b>	Syngas

**Technical Description of Technology**

TRI's technology, which processes any organic biomass, including spent liquors, bark, forest residuals, agricultural residuals and energy crops, converts organic carbon to a hydrogen and carbon monoxide synthesis gas ("syngas") that can be used to displace natural gas, be burned in a combined cycle power generation system or be the fundamental building block for the production of biofuels and biochemicals.

TRI's biomass to syngas process can be used to displace or supplement existing chemical and energy recovery systems or integrate a biorefinery into a manufacturing process. The technology offers dramatic competitive advantages to industry in terms of energy efficiency, operating cost effectiveness, environmental compliance, new products, and new revenue streams.

**Environmental Considerations**

The TRI process is carbon neutral. TRI's biomass-to-energy processes are not water-intensive. Large-scale work with [Norampac](#) in Canada is all done with the client remaining a "zero effluent discharge facility," the highest standard for such a facility.

**Examples of Real Life Applications**

Norampac Trenton, Ontario, Canada

Norampac is the largest manufacturer of containerboard in Canada. Its Trenton mill produces 500 tons per day of corrugating medium from mixed hardwoods, semi-chem pulp and old corrugated containers (OCC). The mill is a zero effluent facility and is committed to the highest environmental standards and operating efficiency. Prior to installing the TRI spent liquor gasification system the mill had no chemical and energy recovery process. Spent liquor was stored in ponds and sold to local counties for use as a soil binder and dust suppressant on gravel and dirt roads. This practice was terminated in 2002. After reviewing all options for the processing of spent liquor, Norampac chose the TRI system because it would provide the

---

<sup>17</sup> [http://www.tri-inc.net/contact\\_us.html](http://www.tri-inc.net/contact_us.html)



capability for both chemical and energy recovery, have minimal environmental impact, have a scale-up and turndown capability to meet current and future mill needs, allow the mill to continue as a zero effluent operation, and be affordable.

The spent liquor gasifier is designed to process 115 Metric tons per day of black liquor solids (at 40% moisture content). The chemicals are recovered and sent to the mill for pulping and the energy is recovered as steam which offsets the production of steam using purchased natural gas. The process started up in September of 2003. The project completed its performance test in April of 2005 and it completed air emissions testing in October 2006 thereby transitioning from commissioning to full commercial operation. The gasifier has logged more than 18,000 hours of operation.

### ***Georgia-Pacific Corporation, Big Island, Virginia***

Georgia-Pacific Corporation, one of the world's largest paper companies. The Big Island mill produces 900 tons per day of linerboard from OCC and 600 tons per day of corrugating medium from mixed hardwoods semi-chem pulp. The project was environmentally driven and displaced two 50 year-old smelters that provided chemical recovery but no energy recovery. The project was funded 50% by the U.S. Department of Energy as a demonstration project for low temperature spent liquor gasification. The system was designed to process 200 tons per day of black liquor solids (at 40% moisture).

Starting in the first quarter of 2004, Georgia-Pacific commissioned TRI's steam reforming spent liquor gasification process at its Big Island, Virginia mill. The start-up and operation of the reformer system was not nearly as successful as the similar system at Norampac, and in October of 2006, Georgia-Pacific decided to no longer continue operation of their reformers. Their decision was based on the expected cost of modifying the reformer to improve performance. In contrast to Norampac, GP's system was designed by another engineering company and incorporated significantly different process designs than those implemented by TRI at Norampac.

### **Suppliers**

TRI

3700 Koppers Street, Suite 405 Baltimore, MD 21227

Telephone: 410-525-2400 Fax: 410-525-2408

## 2-Drum Bottom Supported Boiler<sup>18</sup> USA, Commercial

<b>Crop</b>	Sugarcane, coconut, coffee, corn, peanut, rice, switch grass
<b>Residue</b>	Bagasse, coconut hulls, coffee grounds, corn cobs, peanut hulls, rice husks, switch grass
<b>Process</b>	Combustion
<b>Equipment</b>	Boiler
<b>Main Products</b>	Heat and Steam
<b>Production Capacity</b>	

2-Drum Bottom Supported Boiler Design Parameters	
<b>•Steam capacities</b>	40,000 LB/hr to 200, 000 lb/hr (18 t/hr to 82 t/hr)
<b>•Maximum design pressure</b>	1200 psig (82 bar)
<b>•Maximum steam temperature</b>	900°F(482°C)
<b>•Furnace construction</b>	Tube & tile or membrane wall

<sup>18</sup> <http://www.mcburney.com/biomass.htm#mod>

## Detailed Process Description

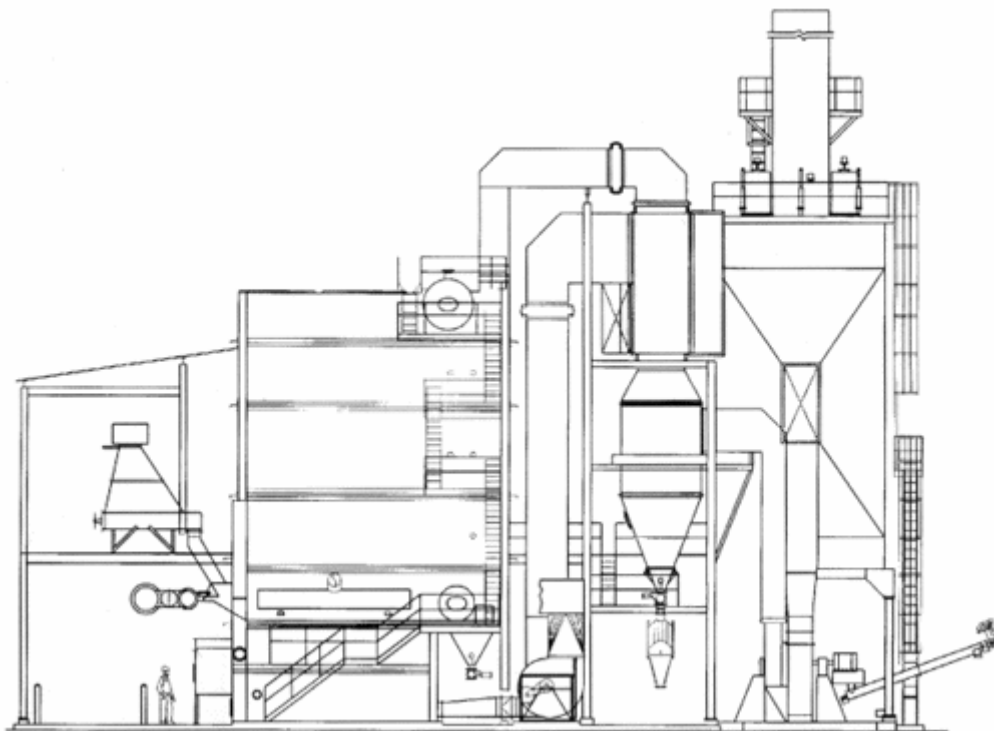

## Environmental Considerations

Company has air pollution control system

## Institutional and Regulatory Consideration or Requirements

- Performed in strict accordance with the applicable ASME Boiler and Pressure Vessel Codes, the National Board Inspection Code, and any jurisdictional requirements that may apply. McBurney currently holds the following ASME and National Board Certificates of Authorization:

- A** for the assembly of power boilers which are designed and manufactured by others.
- PP** for the design, alteration, manufacture, and erection of power piping.
- R** for in-kind repair of boilers and pressure vessels.
- S** for the design, alteration, manufacture, and erection of

power boilers.

**Examples of Real Life Applications**

Commercial use                      2-Drum Bottom Supported Boiler                      1650  
International Court

Suite 100 Norcross, GA

30093

**Supplier**

McBurney

**100 kWe Talbott's Biomass Generator  
United Kingdom, Commercial**

<b>Crop</b>	Energy and Agricultural crops
<b>Residue</b>	Forestry and agricultural wastes, woodchips, wood pellets and energy crops and Miscanthus
<b>Process</b>	Combustion
<b>Equipment</b>	Bunker, combustor, biomass turbine generator
<b>Main Product</b>	Combined heat and electricity

**By-Product**

**Technical Description of Technology**

The Biomass Generator (BG100) is a highly efficient technology capable of producing 100kW of renewable electricity and 200kW of renewable heat. Fuels that can be used in this unit include wood chips, forestry and agricultural residues, short rotation coppice, such as willow, and energy crops, such as Miscanthus. The BG100 converts this biomass, through combustion, into energy in the form of electricity and heat.

The size makes the BG100 ideal for installation on farms, large estates, woodworking factories and anywhere where there is a readily available source of fuel. This technology will lead to added value for crops and will offer an effective end use for energy crops. It will also provide an opportunity to the agricultural community for a much needed, viable diversification option.

The BG100 is a small, compact system designed for on-site power production. Transport of fuel is minimised through the utilisation of on-site or local fuel sources, achieving further emission reductions directly related to the use of this system.

Plant Specifications	
Electrical Power Output (rated)	80 to 100 kW
Generating Voltage/Frequency	415V/ 3 phase / 50 Hz
Grid Protection	Software G59 compliant
Fuel Type	Biomass
Thermal Output	200 to 250 kW
Heat Output Format	Hot water up to 90 degrees Celsius
Operation	Fully Automated Continuous Output

**Detailed Process Description**

A fully automated continuous system ensures proper fuel feeding to maintain the required energy output and the step-grate system helps to ensure even burn throughout the combustion chamber to improve the unit's efficiency.

A triple pass ceramic lined high temperature combustion zone helps maximise efficiency and high combustion temperature making it possible to use fuels with a higher moisture content than would otherwise have been possible. High combustion temperatures ensure clean combustion, meeting all environmental standards. Step grate system with auto de-asher ensures even burn throughout combustion chamber for improved efficiency.

Bunker fuel storage systems are used for ease of loading by a variety of methods with additional storage capacity. Robust, variable fuel mechanism allows varying sized specified biomass to be fed into the boiler.

The indirect fired micro turbine is an integral part of the BG100. High-speed direct drive engine coupled to power electronics to provide high levels of engine efficiency and remove the need for a reduction gearbox and the losses associated with it.

### **Main Products**

Combined heat and electricity

### **Environmental Considerations**

The 100kW of renewable electricity and the 200kW of renewable heat produced by the system will lead to a carbon dioxide emission reduction of around 600 tonnes per unit each year; this is compared to emissions from fossil fuel fired heat and electricity production. This is a significant saving which will greatly benefit the environment by reducing the release of carbon dioxide, a greenhouse gas, into the atmosphere.

### **Investment and Operating Cost**

Processed biomass fuel is ready to be fed into a biomass energy system The BG100 can be operational for approximately 8000 hours per annum.

### **Examples of Real Life Applications**

Harper Adams University College, a leading agricultural university in Shropshire, have installed a Talbott's Biomass Generator.

#### **Source:**

1. [www.talbotts.co.uk](http://www.talbotts.co.uk)

## FIREBOX LPD HF<sup>19</sup> USA, Commercial

<b>Crop</b>	Agricultural materials
<b>Residue</b>	Agricultural residue
<b>Process</b>	Gasification, combustion
<b>Equipment</b>	Boiler Firebox LPD HF
<b>Main Product</b>	Low pressure steam or hot water

### Production Capacity

The Firebox LPD HF design is suitable for applications to produce low-pressure steam or hot water in ranges from 3,450 - 20,700 lbs/hr (3.4 mm BTU - 20 mm BTU) output at 15-PSI steam or 30 PSI hot water.

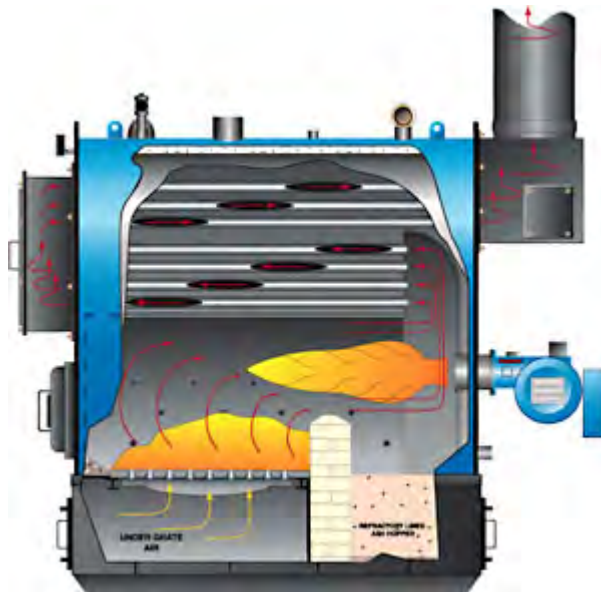

<sup>19</sup> <http://www.hurstboiler.com/biomass.htm>





All above work in concert to reduce solid fuels into usable heat energy utilizing the most reliable system yet devised. Our “cruise control” system orchestrates the operation of each to match the steam load and maintain efficient combustion.

#### **H. “Hybrid” Design Boiler**

Originally built in Germany, the “Hybrid” design is unequalled in the heat recovery from solid fuels.

##### **Ha. Water Tube Section**

The watertube section of the “Hybrid” boiler allows for abundant radiant heating surface. This allows for quicker recovery and more efficient heat transfer than in the typical firetube boiler.

##### **Hb. Fire Tube Section**

The fire tube section of the “Hybrid” boiler allows for greater water volume and thermal reserve than the typical water tube boiler. Quick response with the additional capacity to handle spike loads is the result. In addition, the two pass design increases gas velocity and efficiency and a cleaner boiler result.

##### **Hc. Steam Space**

The fire tube section of the “Hybrid” also allows for several times the steam space of a typical boiler. The larger steam release surface is calmer, reducing carry over of unevaporated water. The resulting drier steam also reduces system scaling. In addition, dry steam helps eliminate unnecessary extra condensate. Energy and fuel are saved.

#### **I. Boiler Blowdown**

##### **J. Handhole**

The waterside openings are located in the most effective positions. The lower hand holes offer far better access for both clean out and inspection.

##### **K. Manway**

##### **L. Continuous Blowdown**

##### **M. Soot Blower**

Fixed zone

##### **N. Insulation And Jacketing**

2' High Density fiberglass insulation and 22 ga. zinc coated metal jacket.

##### **O. Rear Smoke Box**

Liberal and easy accessible gas turn around area. No large refractory doors or wet back to work around.

##### **P. Reinjection Blower**

Continuously cleans rear smoke box.

##### **Q. Skids and Support Structure**

Unit is skid mounted with rear supports for easy handling and set-up.

#### **Operation and Maintenance Requirements**

5. Ash removal is a manual operation.
6. The company stocks replacement parts for the boilers and other major competitors' boilers as well. Manufacturing facility is in Coolidge, GA, supports parts center with the latest technology and competitive rates, offering shipping with Emory, DHL, Fed Ex and "UPS On Line Shipping / Tracking" for speedy delivery of critical parts orders to any facility in a timely fashion.

**Examples of Real Life Applications**

Commercial use FIREBOX LPD HF Highway 319 N. Coolidge, GA  
31738

**Supplier**

Hurst Boiler and Welding Co., Inc.

**FIREBOX LPD UF<sup>20</sup>**  
**USA, Commercial**

<b>Crop</b>	Agricultural materials
<b>Residue</b>	Agricultural residue
<b>Process</b>	Gasification, combustion
<b>Equipment</b>	Boiler Firebox LPD UF
<b>Main Product</b>	Low-pressure steam or hot water

**Production Capacity**

The Firebox LPD UF design is suitable for applications to produce low-pressure steam or hot water in ranges from 3,450 - 20,700 lbs/hr (3.4 mm BTU - 20 mm BTU) output at 15-PSI steam or 30 PSI hot water.

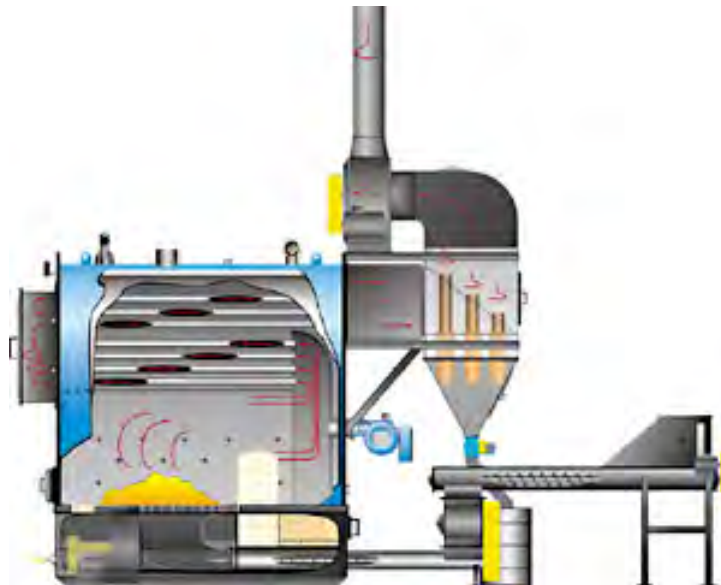

---

<sup>20</sup> <http://www.hurstboiler.com/biomass.htm>

## Detailed Process Description

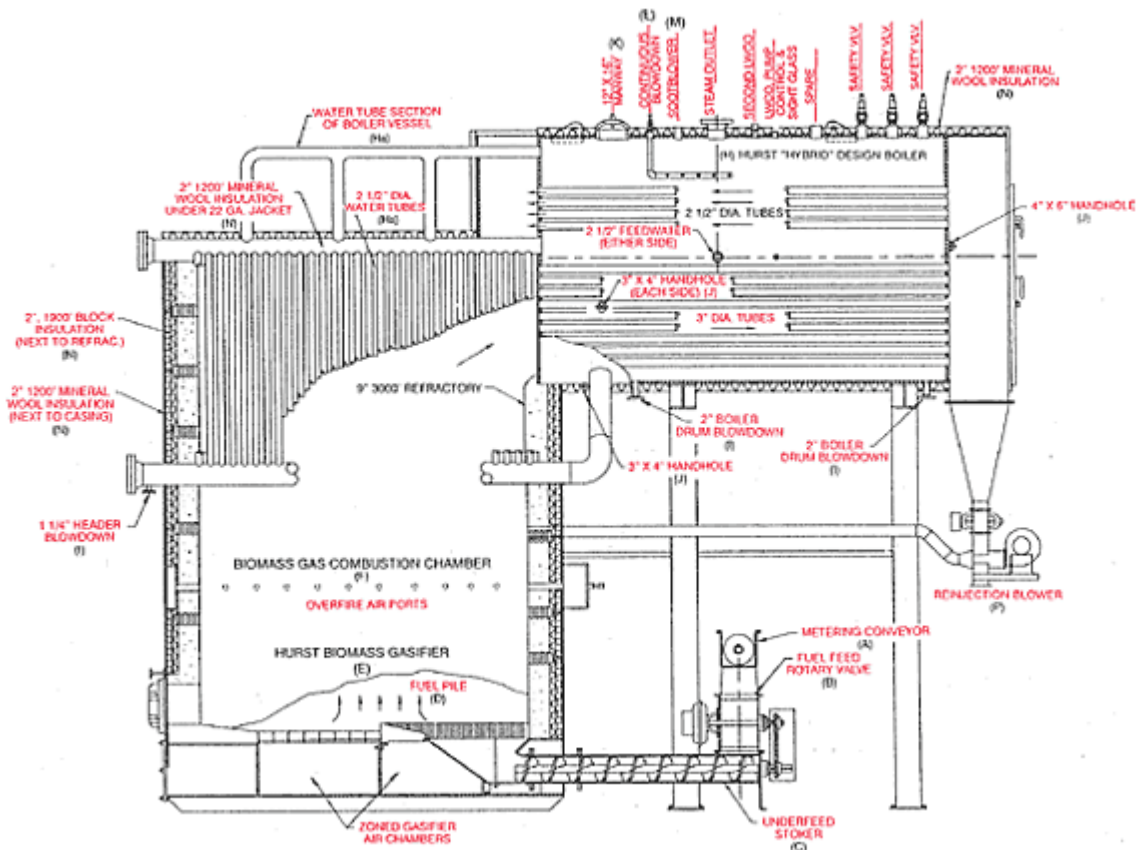

### A. Metering Conveyor

Extra Heavy Duty Screw Conveyor with Variable Frequency AC Drive

### B. Rotary Air Lock Valve

Limits Excess Air for Improved Combustion Control, Increased Efficiency and Emission Control

### C. "Frederick" Solid Fuel Stoker

Manufactured since 1918, it is unsurpassed in the dependable stoking of solid fuels

### D. Fuel Pile

The fuel pile, maintained by the stoker, covers all the grates for Improved Combustion Efficiency and Emission Control.

### E. Gasifier

A combination of the "Frederick" stoker, combustion air system, and lower combustion chamber. The Hurst "Gasifier" vaporizes the volatile gasses from the solid fuel, driven by the remaining carbon on the grates.

### F. Combustion Chamber

Combustion Air is mixed with the volatile gas created by the gasifier and burned in this area of the furnace.

### G. Combustion Air System

Two blowers, one under fire and one over fire, furnishes and controls the volume of air entering the Gasifier and Combustion Chamber. All above work in concert to reduce solid fuels into usable heat energy utilizing the most reliable system yet devised. Our "cruise control" system orchestrates the operation of each to match the steam load and maintain efficient combustion.

All above work in concert to reduce solid fuels into usable heat energy utilizing the most reliable system yet devised. Our “cruise control” system orchestrates the operation of each to match the steam load and maintain efficient combustion.

#### **H. “Hybrid” Design Boiler**

Originally built in Germany, the “Hybrid” design is unequalled in the heat recovery from solid fuels.

##### **Ha. Water Tube Section**

The watertube section of the “Hybrid” boiler allows for abundant radiant heating surface. This allows for quicker recovery and more efficient heat transfer than in the typical firetube boiler.

##### **Hb. Fire Tube Section**

The fire tube section of the “Hybrid” boiler allows for greater water volume and thermal reserve than the typical water tube boiler. Quick response with the additional capacity to handle spike loads is the result. In addition, the two pass design increases gas velocity and efficiency and a cleaner boiler result.

##### **Hc. Steam Space**

The fire tube section of the “Hybrid” also allows for several times the steam space of a typical boiler. The larger steamrelease surface is calmer, reducing carry over of unevaporated water. The resulting drier steam also reduces system scaling. In addition, dry steam helps eliminate unnecessary extra condensate. Energy and fuel are saved.

#### **Boiler Blowdown**

##### **J. Handhole**

The waterside openings are located in the most effective positions. The lower hand holes offer far better access for both clean out and inspection.

##### **K. Manway**

##### **L. Continuous Blowdown**

##### **M. Soot Blower**

Fixed zone

##### **N. Insulation And Jacketing**

2' High Density fiberglass insulation and 22 ga. zinc coated metal jacket.

##### **O. Rear Smoke Box**

Liberal and easy accessible gas turn around area. No large refractory doors or wet back to work around.

##### **P. Reinjection Blower**

Continuously cleans rear smoke box

##### **Q. Skids and Support Structure**

Unit is skid mounted with rear supports for easy handling and set-up.

#### **Operation and Maintenance Requirements**

7. Ash removal is a manual operation.
8. The company stocks replacement parts for the boilers and other major competitors' boilers as well. Manufacturing facility is in Coolidge, GA, supports parts center with the latest technology and competitive rates, offering shipping with Emory, DHL, Fed Ex and "UPS On Line Shipping / Tracking" for speedy delivery of critical parts orders to any facility in a timely fashion.

### **Examples of Real Life Applications**

Commercial use FIREBOX LPD UF Highway 319 N. Coolidge, GA 31738

### **Suppliers**

Hurst Boiler and Welding Co., Inc.

**Fibrowatt Technology producing Electricity from Poultry Litter and  
Agricultural Waste  
U.S.A., Commercial**

<b>Crop</b>	Alfalfa, Corn, Rice and poultry litter
<b>Residue</b>	Straw, Residues
<b>Process</b>	Combustion
<b>Equipment</b>	Boiler, Conveyor, Furnace, Condenser, Turbine
<b>Main Product</b>	Electricity
<b>By-Product</b>	

**Technical Description of Technology**

Fibrowatt has 15 years of operating experience using a proven technology that supplies enough electricity from three plants in the United Kingdom to serve 150,000 homes. Fibrominn generates enough electricity to serve 40,000 homes. Through long-term contracts and spot market purchases, Fibrowatt obtains poultry litter from surrounding farms. The process begins with poultry house cleaning, then the poultry litter is transported in tightly covered trucks to a fuel storage building, where jobs once operational (30 on-site jobs, 60 in litter transportation, and 10 at the ash fertilizer plant), and an economy boosted by increased local wages, spending, and tax revenues.

The technology used by Fibrowatt has been well proven by the management team in the three plants which they developed in the United Kingdom in the 1990s. Those plants, which have now been sold to a new owner, were the world's first three poultry litter fueled power plants. Over the past 15 years, they have turned more than seven million tons of poultry litter and other biomass into enough electricity to serve 150,000 British homes. Today, Fibrowatt is introducing its proven technology in select communities around the United States and continually improving upon its processes.

**Detailed Process Description**

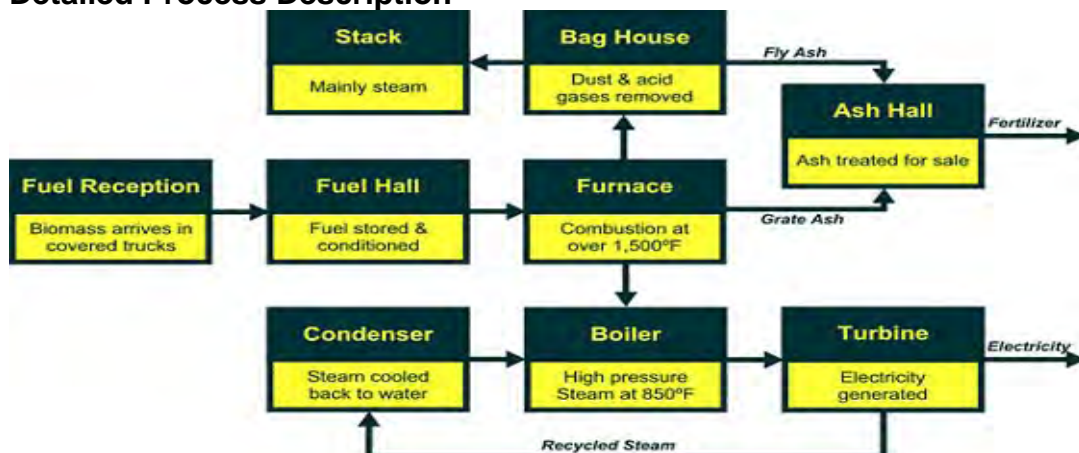

**Figure 1. Schematic Diagram of Fibrowatt Technology**

1. The Fibrowatt operation starts on the farm, where poultry house cleaning and litter removal are coordinated with the farmer.
2. Poultry litter is transported in tightly covered trucks on pre-arranged routes to the plant's fuel storage building. Truck routing is designed to minimize the biosecurity risk to existing poultry operations and reduce truck traffic impact on local communities.
3. Trucks unload the litter within a specially designed fuel storage building, which typically holds five to ten days' worth of fuel. The building is kept at negative pressure to prevent the escape of odors and, as a result, odors are undetectable beyond the plant site's boundaries.
4. From the fuel storage building, fuel travels on a conveyor system to the boiler. Fans draw air from the storage building into the boiler, where the litter is combusted at more than 1,500°F, ensuring the destruction of pathogens and complete combustion.
5. Water is heated in the boiler to produce high-pressure, high-temperature steam, which drives a turbine and generates electricity.
6. Renewable energy from poultry litter and other biomass, unlike fossil fuel-generated energy, results in no new carbon dioxide releases. Because Fibrowatt plants utilize a clean-burning fuel and advanced pollution-control equipment, the plants meet strict limits for each of the major gases emitted by the combustion process. Air emissions are regulated and monitored by a Continuous Emissions Monitoring System (CEMS) that logs and reports on emission performance.
7. Fibrowatt sells its renewable energy to electricity providers. The Fibrominn plant produces enough green electricity to serve 40,000 homes.
8. When poultry litter is combusted to produce electricity, a nutrient-rich by-product is produced in the form of ash. Fibrowatt plants recover this ash for processing. The fertilizer can be used to fertilize row crops, provide nutrients to managed forest farms, and in various other ways.

## **Main Products**

Electricity

## **Environmental Considerations**

Fibrowatt is the only experienced developer of power plants fueled by poultry litter and other agricultural biomass in the world. Its technology results in a variety of positive environmental impacts, including using locally abundant biomass, producing renewable energy, preventing over-application of poultry litter and recycling valuable nutrients.

Biomass used by the technology include:

- animal waste and bedding (such as poultry litter)
- dedicated energy crops
- agricultural by-products



- crop residues (such as alfalfa stems and corn residues)
- wood and wood wastes
- grasses

### **Investment and Operating Cost**

Communities with Fibrowatt plants benefit from an average of several hundred-construction jobs, 100 fulltime jobs once operational (30 on-site jobs, 60 in litter transportation, and 10 at the ash fertilizer plant), and an economy boosted by increased local wages, spending, and tax revenues.

### **Examples of Real Life Applications**

Minnesota: Fibrominn completed  
 North Carolina: Projects under development  
 Arkansas: Project under development  
 Mississippi: Fibromiss under development  
 Maryland: Fibroshore under development

### **Supplier:**

Pennsylvania headquarters  
 Fibrowatt LLC  
 One Summit Square, Suite 200  
 1717 Langhorne-Newtown Road  
 Langhorne, PA 19047  
 Phone: 267/352-0014  
 Fax: 267/352-0035  
 E-mail: info@FibrowattUSA.com

Kasia Wieronski, 267/352-0014  
 Fibrominn - Minnesota  
 Fibrominn, LLC  
 900 Industry Drive  
 PO Box 265  
 Benson, MN 56215  
 Telephone: (320)843-9013  
 Fax: (320)843-9014

### **Sources:**

1. <http://www.fibrowattusa.com/index.cfm>
2. <http://www.fibrowattusa.com/cm/pdfs/fibrowatt.pdf>

## HYBRID CG<sup>21</sup> USA, Commercial

<b>Crop</b>	Agricultural materials
<b>Residue</b>	Agricultural residue
<b>Process</b>	Gasification, combustion
<b>Equipment</b>	Boiler Hybrid CG
<b>Main Product</b>	High pressure steam or hot water

### Production Capacity

The Hybrid CG design is suitable for applications to produce high pressure steam or hot water in ranges from 3,450 - 60,000 lbs/hr (3.4 mm BTU - 60 mm BTU) output from 100 up to 400 PSI.

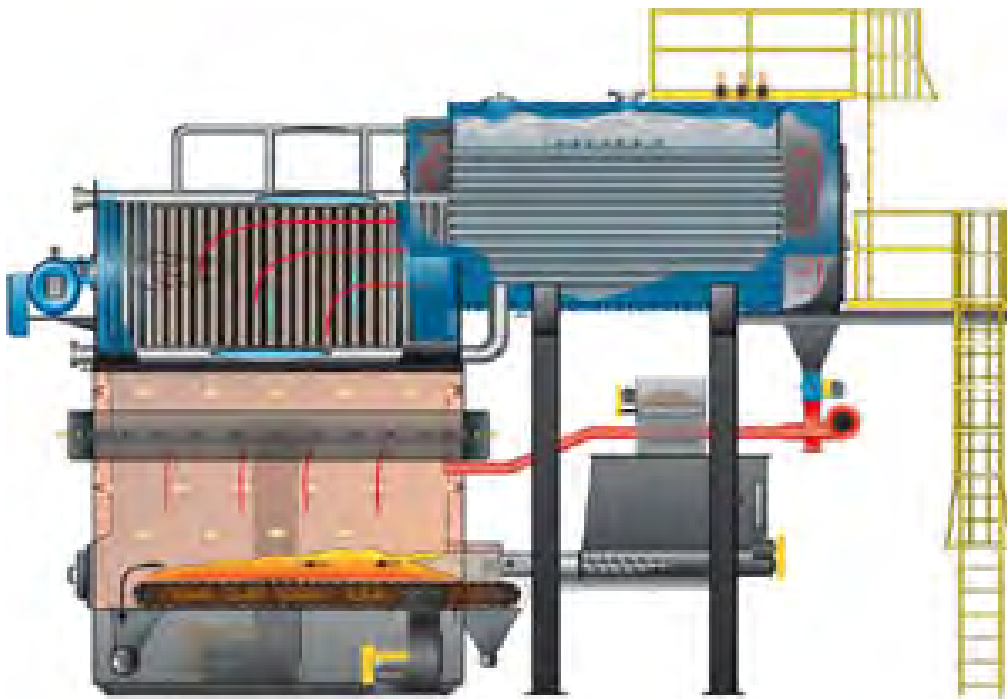

<sup>21</sup> <http://www.hurstboiler.com/biomass.html>

## Detailed Process Description

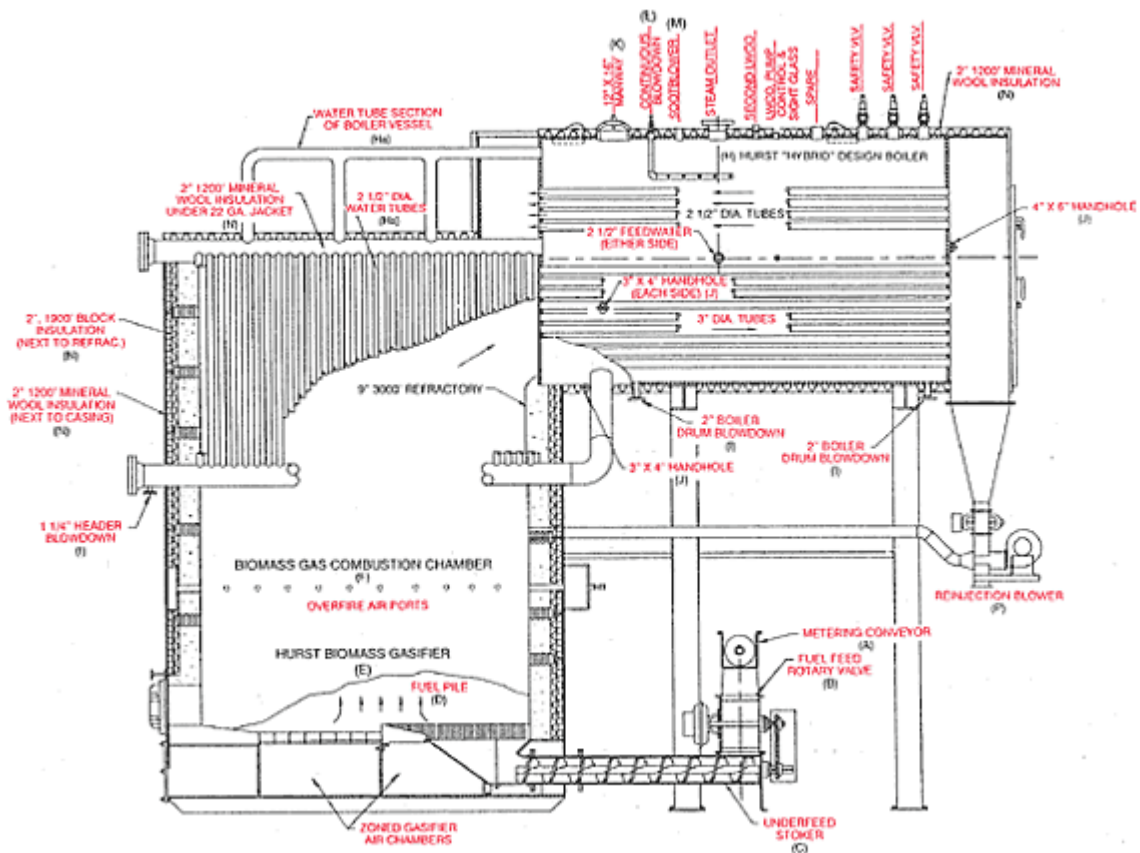

### A. Metering Conveyor

Extra Heavy Duty Screw Conveyor with Variable Frequency AC Drive

### B. Rotary Air Lock Valve

Limits Excess Air for Improved Combustion Control, Increased Efficiency and Emission Control

### C. "Frederick" Solid Fuel Stoker

Manufactured since 1918, it is unsurpassed in the dependable stoking of solid fuels

### D. Fuel Pile

The fuel pile, maintained by the stoker, covers all the grates for Improved Combustion Efficiency and Emission Control.

### E. Gasifier

A combination of the "Frederick" stoker, combustion air system, and lower combustion chamber. The Hurst "Gasifier" vaporizes the volatile gasses from the solid fuel, driven by the remaining carbon on the grates.

### F. Combustion Chamber

Combustion Air is mixed with the volatile gas created by the gasifier and burned in this area of the furnace.

### G. Combustion Air System

Two blowers, one under fire and one over fire, furnishes and controls the volume of air entering the Gasifier and Combustion Chamber. All above work in concert to reduce solid fuels into usable heat energy

utilizing the most reliable system yet devised. Our “cruise control” system orchestrates the operation of each to match the steam load and maintain efficient combustion. All above work in concert to reduce solid fuels into usable heat energy utilizing the most reliable system yet devised. Our “cruise control” system orchestrates the operation of each to match the steam load and maintain efficient combustion.

**H. “Hybrid” Design Boiler**

Originally built in Germany, the “Hybrid” design is unequalled in the heat recovery from solid fuels.

**Ha. Water Tube Section**

The watertube section of the “Hybrid” boiler allows for abundant radiant heating surface. This allows for quicker recovery and more efficient heat transfer than in the typical firetube boiler.

**Hb. Fire Tube Section**

The fire tube section of the “Hybrid” boiler allows for greater water volume and thermal reserve than the typical water tube boiler. Quick response with the additional capacity to handle spike loads is the result. In addition, the two pass design increases gas velocity and efficiency and a cleaner boiler result.

**Hc. Steam Space**

The fire tube section of the “Hybrid” also allows for several times the steam space of a typical boiler. The larger steam release surface is calmer, reducing carry over of unevaporated water. The resulting drier steam also reduces system scaling. In addition, dry steam helps eliminate unnecessary extra condensate. Energy and fuel are saved.

**I. Boiler Blowdown**

**J. Handhole**

The waterside openings are located in the most effective positions. The lower hand holes offer far better access for both clean out and inspection.

**K. Manway**

**L. Continuous Blowdown**

**M. Soot Blower**

Fixed zone

**N. Insulation And Jacketing**

2’ High Density fiberglass insulation and 22 ga. zinc coated metal jacket.

**O. Rear Smoke Box**

Liberal and easy accessible gas turn around area. No large refractory doors or wet back to work around.

**Operation and Maintenance Requirements**

9. The new HBC chain grate-type stoker system permits a wide range of biomass fuels with high ash contents to be combusted in an efficient manner with the added advantage of automatic de-ashing.
10. The company stocks replacement parts for the boilers and other major competitors' boilers as well. Manufacturing facility is in Coolidge, GA, supports parts center with the latest technology and competitive rates, offering shipping with Emory, DHL, Fed Ex and "UPS On Line Shipping / Tracking" for speedy delivery of critical parts orders to any facility in a timely fashion.

### **Examples of Real Life Applications**

Commercial use    Hybrid CG    Highway 319 N. Coolidge, GA 31738

### **Suppliers**

Hurst Boiler and Welding Co., Inc.

## BTG Flash Pyrolysis Netherlands, Commercial

<b>Crop</b>	Rice, Olives, Switchgrass
<b>Residue</b>	Wood residues, straw, husks
<b>Process</b>	Pyrolysis
<b>Equipment</b>	hopper feeder, stack, heat exchanger pyrolysis reactor, rotating cone reactor
<b>Main Product</b>	Oil, gas and char

### Technical Description of Technology

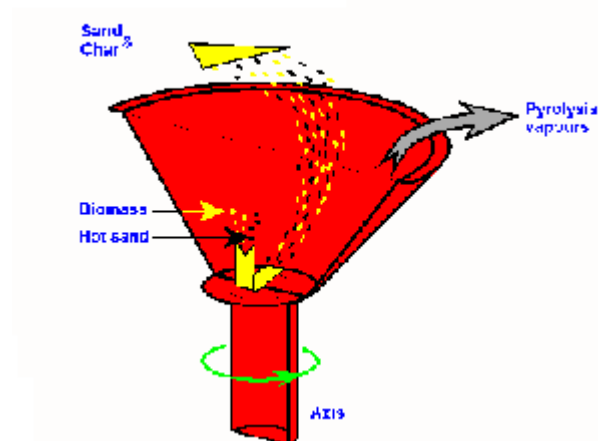

**Figure 1. Rotating Cone Reactor**

BTG's fast pyrolysis technology is based on the rotating cone reactor. It is a proven gas-solid contactor which has been developed at the University of Twente (Chem.Eng. Sci., 5109, (1994)). A schematic representation of the reactor is presented in the figure above. Biomass particles at room temperature and hot sand particles are introduced near the bottom of the cone where the solids are mixed and transported upwards by the rotating action of the cone. In this type of reactor, rapid heating and a short gas phase residence time can be realized.

Fast heating of biomass will prevent char forming reactions. In this mode, 75 wt.% bio-oil and only 15 wt.% char and gas are produced as primary products. Rapid removal of the pyrolysis vapours from the hot reactor enclosure ensures that less than 10 wt.% bio-oil is lost due to cracking reactions. Since no "inert" carrier gas is needed (unlike fluidized bed pyrolysis), the pyrolysis products are undiluted. This undiluted and hence small vapour flow results in downstream equipment of minimum size. Consequently, the capital costs of the complete unit are minimal.

In mechanical terms, the reactor technology is remarkably simple and robust. The rotational speed of the cone is only 300 rpm and after more than 1000 hours of operation in the current 250 kg/h pilot plant signs of abrasion or wear are absent

Scaling up of the rotating cone reactor is possible by increasing its diameter. For capacities, which require a cone diameter larger than 2 meters, stacking of multiply cones on a single axis leads to the lowest investment costs. This conventional approach is also encountered in centrifugal disk separators or rotating disks contactors. With these options all pilot plant capacities between 2 and 100 ton/hr can be served.

### Detailed Process Description

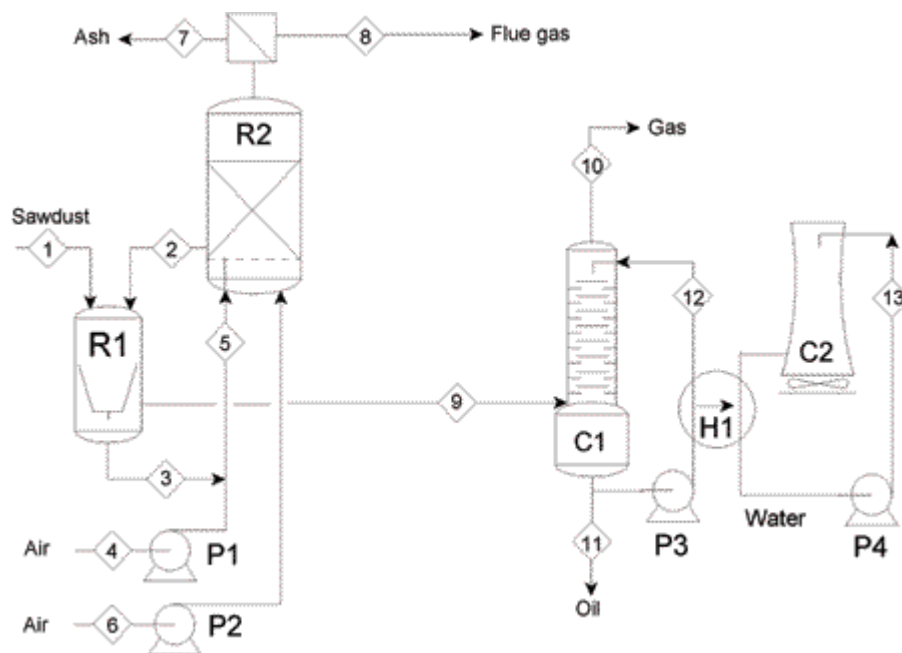

Biomass particles are fed near the bottom of the pyrolysis reactor together with an excess flow of hot heat carrier material such as sand, where it is being pyrolysed. The produced vapours pass through several cyclones (not shown) before entering the condenser, in which the vapours are quenched by re-circulated oil. The pyrolysis reactor is integrated in a circulating sand system composed of a riser, a fluidized bed char combustor, the pyrolysis reactor, and a down-comer. In this concept, char is burned with air to provide the heat required for the pyrolysis process. In this case the plant is self-sustaining. Oil is the main product; non-condensable pyrolysis gases are currently flared-off, but application in a gas engine is foreseen. Excess heat can be used for drying the feedstock.

### Main Products

Gas, bio-oil and char

### Operation and Maintenance Requirements

Before processing organic materials in a fast pyrolysis plant, the feedstock must have the following requirements:

particle size < 6 mm,  
moisture content < 10 wt.%

### **Environmental Considerations**

Bio-oil can substitute for fuel oil or diesel in many static applications including boilers, furnaces, engines and turbines for electricity generation. The gases 10 wt.% can be fired in a boiler or in a gas engine. Finally, the char 15 wt.% may be combusted in the pyrolysis unit to drive the process auto-thermally. Only the ash is left as a waste stream.

Other advantages include:

1. Bio-oil is cleaner than biomass.
2. The ash content in bio-oil is a factor 100 lower than biomass.
3. Minerals like K, Cr, and Cu remain in the char.
4. The cost of bio-oil production is relatively low due to the mild conditions.

### **Example of Real Life Application**

Aston University (UK), BHF-IWCT (GE), Wellman (UK), KARA (NL), Ormrod Diesels (UK)

### **Supplier**

BTG biomass technology group BV  
R&D Department  
Pantheon 12  
7521 PR Enschede  
The Netherlands  
Tel. + 31-53-4862287  
Fax +31-53-4325399  
E-mail: [wagenaar@btgworld.com](mailto:wagenaar@btgworld.com)  
Web: [www.btgworld.com](http://www.btgworld.com)



## Heat and Steam from Sugarcane Leaf and Bagasse India, Commercial

<b>Crop</b>	Sugar cane
<b>Residue</b>	Bagasse and leaf
<b>Process</b>	Gasification
<b>Equipment</b>	Gasification system
<b>Main Product</b>	Heat and Steam
<b>By-Product</b>	

### Technical Description of Technology

#### <sup>22</sup>GASIFICATION SYSTEM DESIGN

Certain critical engineering design norms of the gasification system were first developed on a laboratory-scale model and were then validated on a bench-scale model 6, 7 . These norms were then used to design a full-fledged commercial scale system with a thermal output of 1080 MJ h<sup>-1</sup> . This system (presently installed in the NARI campus) is seen in Fig. 1. It comprises of a reactor, a gas conditioning system, a biomass feeding system and the instrumentation and controls. A schematic diagram of this system is shown in Fig. 2. The salient features of these components are given below.



Fig 1.



Fig. 3.

<sup>22</sup> <http://nariphaltan.virtualave.net/Gasifier.pdf>

a. **Reactor** : This was a downdraft, throatless and open-top reactor with an internal diameter of 75 cm and an active bed height of 1.25 m. It was designed for a heavy-duty cycle of 7500 hour per year operation. High temperature resisting firebricks conforming to IS 8 grade were used for the hot face followed by a cold face insulation.

b. **Gas conditioning system** : A completely dry dust collection system eliminated altogether the problem of wastewater. This consisted of a high temperature char/ash coarse settler and a high efficiency cyclone separator. A specifically designed high temperature resisting induced-draft fan ensured that the entire system is under negative pressure so that in the event of leaks, outside air got sucked into the system, but the combustible gas did not leak out. Thus, this design is very environment-friendly. The char-ash from the coarse settler and the cyclone was collected in barrels and emptied in an ash pit once every forty-five minutes. This char-ash which typically has a gross calorific value of 18.9 MJ kg<sup>-1</sup> can be briquetted to form an excellent fuel, or can be used as a soil conditioner 8, 9 .

c. **Biomass feeding system** : This consisted of a scraper drag-out conveyor and a hopper to convey the biomass fuel from the storage pile to the reactor. The conveyor was completely enclosed.

d. **Instrumentation and Control System** : A Programmable Logic Controller (PLC)-based control system seen in Fig. 3 was designed to take automatic corrective actions under certain critical conditions. Thus, the biomass feeding and ash removal rates were fully controlled by this system. Besides, it also helped the operator in trouble-shooting by monitoring temperatures at various critical points in the gasification system. Automatic burner sequence controllers were provided for ignition of the producer gas.

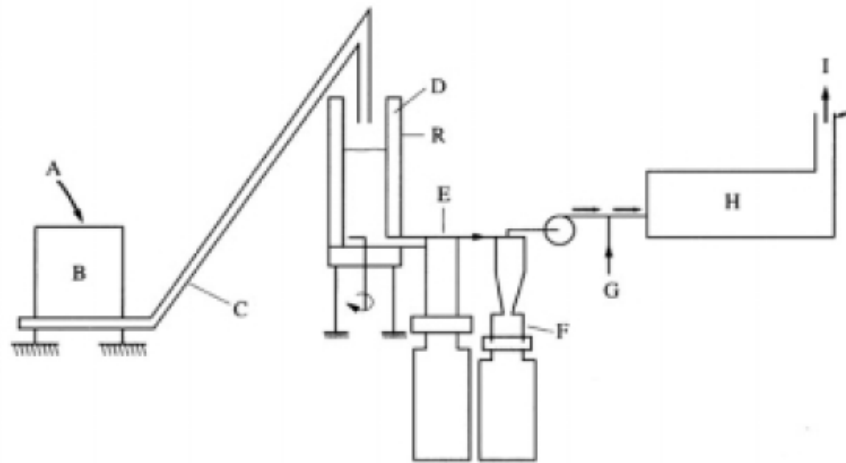

Fig. 2. Schematic diagram of sugarcane leaf-bagasse gasification system: A, biomass from storage piles; B, hopper; C, conveyor; D, refractory; E, char collector; F, cyclone; G, air; H, furnace ( $1080 \text{ MJ h}^{-1}$ ); I, chimney; R, reactor.

The gasification system was extremely simple to operate. A cold start took about ten-fifteen minutes whereas a hot start was effected in less than five minutes. Only two operators per shift of eight hours were required to operate the system, including the fuel and ash handling operations.

### 3. FUEL CHARACTERISTICS

The gasification system was successfully tested on sugarcane leaves and bagasse, sweet sorghum stalks and bagasse, bajra stalks etc. The physical properties of sugarcane leaves and bagasse under the actual operating conditions of the gasifier are given in Table 17 .

### Investment and Operating Cost

The economic analysis of the system was evaluated both at its rated capacity of  $1080 \text{ MJ h}^{-1}$  and at an output level of  $675 \text{ MJ h}^{-1}$  which was usually required during the field tests. The data used for this analysis are given in Table 5.

TABLE 5 : ECONOMICS OF THE NARI GASIFICATION SYSTEM

Economic data (Gasifier rating = 1080 MJ h <sup>-1</sup> )	
1. Cost of the gasifier system	: Rs. 5,25,000 (1 US \$ = Rs. 31) (1995 prices)
2. Civil construction cost	: Rs. 25,000
3. No. of intended hours of operation	: 7500 hours year <sup>-1</sup>
4. Depreciation	: 20% per annum by straight-line method
5. Interest	: 18% per annum annualized over 5 years
6. Wages + Salaries	: 2 persons/shift x 3 shifts/day x 365 days/ year x Rs. 50/person/day
7. Maintenance cost	: 20% of the capital cost spread over 5 years
8. Electricity cost	: 6 kW x Rs. 2.5 kWh <sup>-1</sup>
9. Biomass consumption	: 118 kg GJ <sup>-1</sup>

Table 6 gives the energy cost for a net landed biomass cost of Rs. 1,000 T<sup>-1</sup> (dry). The costing for other biomass prices is given in Fig. 5.

TABLE 6 : ENERGY COST DELIVERED TO THE FURNACE (1995 prices) (1 US \$ = Rs. 31)

A. Fixed Cost Components	Rs./year	
1. Depreciation	1,10,000	
2. Interest	53,750	
3. Maintenance	22,000	
4. Wages + Salaries	1,10,000	
5. Electricity	1,12,500	
Total fixed cost, Rs./year	4,08,250	
<b>ENERGY COST, Rs./GJ</b>	<b>Gasifier output</b>	
	<b>675 MJ h<sup>-1</sup></b>	<b>1080 MJ h<sup>-1</sup></b>
1. Fixed cost, Rs./GJ	79.6	50.4
2. Fuel cost, Rs./GJ (@ Rs. 1000/T)	118.0	118.0
TOTAL ENERGY COST, Rs./GJ	197.6	168.4
Light Diesel Oil (LDO) Cost, @Rs.7.5/l	Rs./GJ 280.3	

Fig. 5 shows that the system is economically attractive if the biomass cost (dried, sized and landed cost at the gasifier site) is less than Rs. 1,100 T<sup>-1</sup> (dry) when the LDO price is Rs. 7.51<sup>-1</sup> and when the

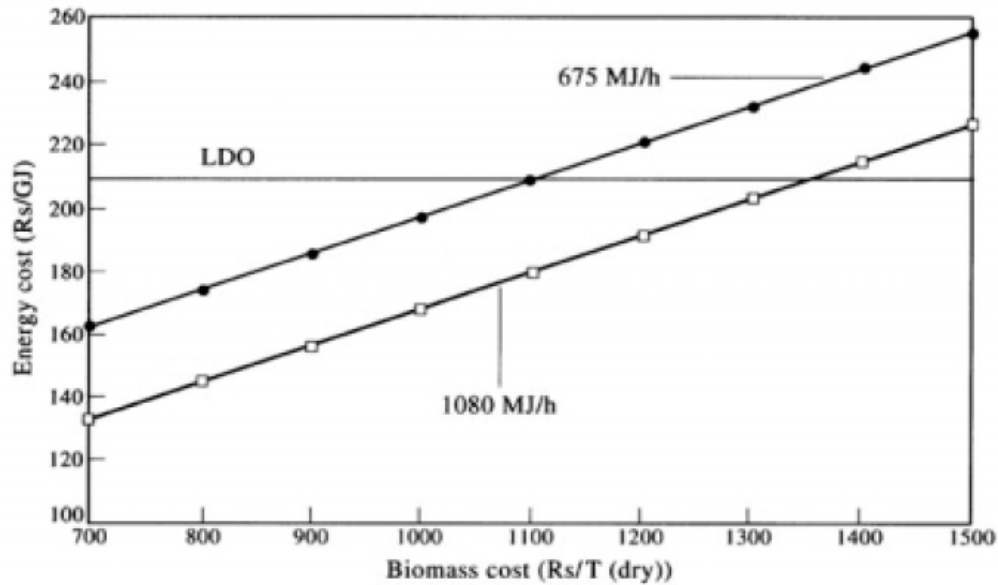

Fig. 5. Economics of the gasification system.

gasifier system is operating at 675 MJ h<sup>-1</sup>. However, if the gasifier system operates at its rated capacity of 1080 MJ h<sup>-1</sup>, the economics is attractive even for biomass cost of Rs. 1350 T<sup>-1</sup> (dry).

Data collected over two years in a sugarcane growing area show that the landed, sized and dried cost of sugarcane leaves is Rs. 900-1100 T<sup>-1</sup> if the material is procured from within a 20-30 km radial distance<sup>9</sup>. For industries located in such areas, the gasifier system can effect considerable savings in their fuel oil costs. Further, larger-scale units of capacities upto 3600 MJ h<sup>-1</sup> can be designed based on the engineering data generated on the present system.

### Examples of Real Life Applications

**Country:** India

**Level of application:** Commercial

**Supplier:**

Nimbkar Agricultural Research Institute (NARI).

P.O. Box 44, PHALTAN-415523, Maharashtra, INDIA

E-mail : [nariphaltan@sancharnet.in](mailto:nariphaltan@sancharnet.in)

## Dan Chang Bio-energy Project<sup>23</sup> Thailand, Commercial

<b>Crop</b>	Sugarcane
<b>Residue</b>	Bagasse
<b>Process</b>	Combustion
<b>Equipment</b>	Steam turbo generator, vibrating grate boiler
<b>Main Product</b>	Steam and electricity requirements of the sugar mill
<b>By-Product</b>	24 MW of excess electricity to be exported to the national grid through a firm contract of 21 years

### Production Capacity

- a 41 MWe extraction condensing steam turbo-generator;
- two vibrating grate boilers with an hourly capacity of 120 tonnes of steam at 68 bar (a) and 510oC each

### Detailed Process Description

The new 41 MWe bagasse-fired cogeneration project is designed not only to provide the steam and electricity requirements of the sugar mill but also to produce 24 MW of excess electricity to be exported to the national grid through a firm contract of 21 years.

The project consists of the following components:

- a 41 MWe extraction condensing steam turbo-generator;
- two vibrating grate boilers with an hourly capacity of 120 tonnes of steam at 68 bar (a) and 510oC each.

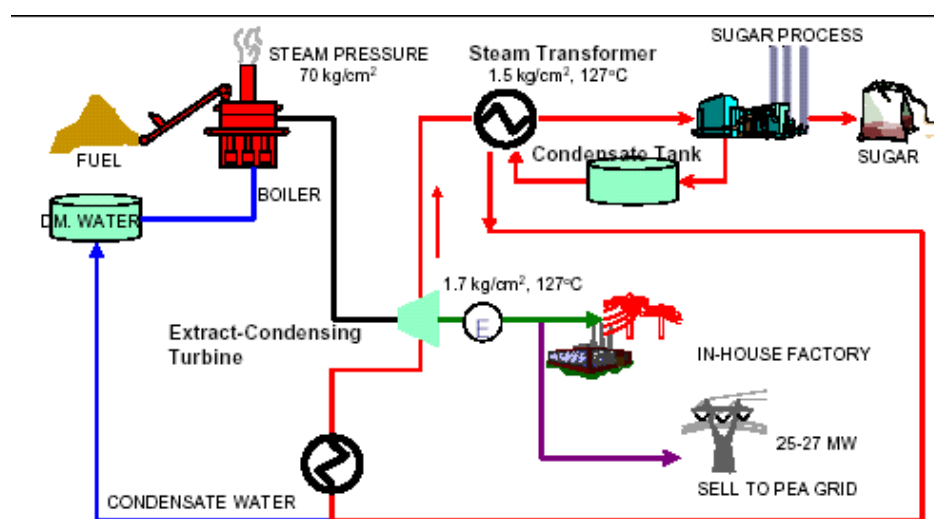

<sup>23</sup> <http://www.cogen3.net/doc/articles/CleanandefficientbiomassCogeneration.pdf>

**Price of Machine** The total investment cost for the project is around Euro 35.5 million, excluding civil works and building foundation. The expected payback period is 5 years after commissioning.

**GHG Emission Reduction Potential**

The total Green House Gas (GHG) Mitigation by implementing this bagasse-fired project is expected around 278,610 tonnes of CO2 equivalent per year.

**Examples of Real Life Applications**

Implemented since 2004 Dan Chang Bio-Energy project Thailand

## Biomass-based Cogeneration Plant Tanzania, Commercial

<b>Crop</b>	Sugar Cane
<b>Residue</b>	Bagasse
<b>Process</b>	Cogeneration
<b>Equipment</b>	
<b>Main Product</b>	Fuel

### Technical Description of Technology

The simplest plant setup of a Bagasse Cogeneration plant (see Figure 1) involves the installation of a boiler producing higher steam pressure than required for the process. This steam is passed through a steam turbine where some of the energy is used to generate mechanical power for driving an alternator for electricity. The steam exits the turbine at a reduced pressure and is then returned to the boiler as condensate or hot water. The primary objective of the energy system is the production of steam hence the electricity that is produced is governed by the demand for process steam. In some cases especially in sugar mills the electricity becomes a primary product when the steam is excess to requirements such as is the case after milling season. The turbine would then be a condensing one where the steam is returned to the boiler without having to pass through the process. Under these circumstances the plant operates as a bagasse fired power station.

**Figure 1. Structure of a Bagasse Cogeneration Plant**

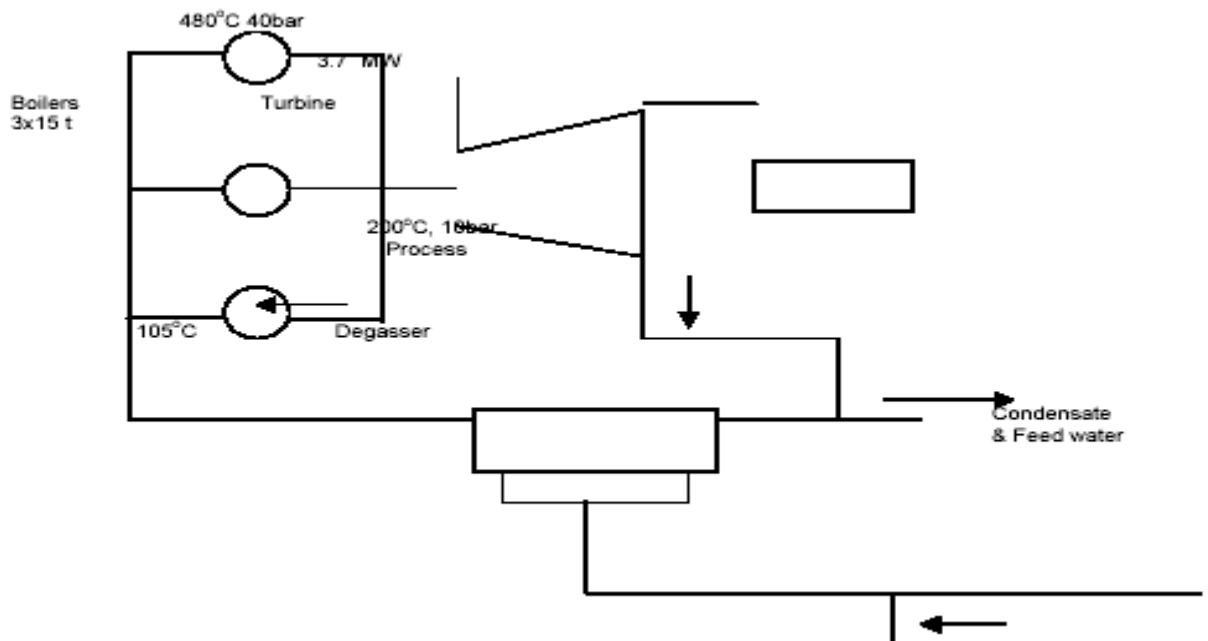



## **Main Products:**

The plant provides its own source of energy for sugar production in the form of bagasse. If well planned, the bagasse can relieve the pressure on the limited resources of fuel and fibre available in Tanzania. From the experiences in sugar industry (Mtibwa Sugar Estate- Cogeneration Workshop in SADC, November 2003), if processed in efficient manner, 1 hectare of cane field can yield 10 tonnes of valuable fibre for fuel, paper and board, 10 tonnes of food products including sugar, 1 m<sup>3</sup> of alcohol and 2 tonnes of fertilizers.

## **Job Potential:**

In Tanganyika Planting Company (TPC) in Tanzania, the factory has a total of 16,000 hectares of land out of which about 6,100 hectares is under cane cultivation. The tonnage of cane at present is about 604,000 tonnes but the field potential in cane production is more than 775,000 tonnes. Assuming that all seasonal employees work in the field during production period then:

636 persons cultivate 604,000 tonnes;  
Therefore 775,000 tonnes will require  $(775,000 \times 636) / 604,000 = 816$  person;  
636 persons generate 2.5 MW; 816 persons generate 12.9 MW;  
Therefore  $(816 - 636)$  persons generate  $(12.9 - 2.5)$  MW ;  
180 persons generate 10.4 MW > 17 person/MW.  
Therefore cogeneration can generate more than 17 jobs (persons/MW).

This concludes that the job creation potential is higher in cogeneration than in conventional energy technology. Likewise, the potential for the enterprises creation is higher with cogeneration technology than the conventional energy, depending on the cogeneration technology employed.

## **Operation and Maintenance Requirements:**

In order to generate electricity to cater only for the plant use, one boiler of capacity 90 tonnes MCR for steam generation and one turbo alternator (back pressure type) of 14 MW for power generation should be installed. Also the pressures and temperature should be raised to 45 bar and 430°C respectively. The total cost for this is estimated to be US\$ 28.5 million. On the other hand for further increase in electricity generation for exporting 7.6 MW to the national grid, one boiler of capacity 140 tonnes MCR for steam generation and one back pressure and condensing turbo alternator of 22 MW for power generation will be required. The temperature and pressure for the process will remain the same that is 430°C and 45 bar respectively. The cost for this is estimated to be US\$ 35.5 million.

## **Social Considerations**

By utilization of this technology it would be possible for Tanzania to reduce its spending of foreign currency on import of petroleum fuels. In a longer time perspective this technology would make it possible to eliminate the constraints upon economic development imposed on Tanzania by the limited amount of foreign currency available for import of petroleum fuels.

The local society would benefit from increased economic independence, primarily by substitution of fuels purchased from the outside by fuels produced locally. This means that a larger fraction of local earnings are spent locally. The users of the technology would benefit from lower energy costs and improved security of supply.

### **Environmental Consideration**

The options for increasing electricity generation in sugar factories have a positive environmental impact. The factory may contribute to the reduction of green house gas emissions by replacing fossil fuelled thermal power plants with biomass-powered plants. Compared to oil and coal fuels, biomass has much lower sulphur content. This reduces SO<sub>2</sub> emissions and lowers the risk of soil and water acidification. The ash content in biomass is lower than in coal, meaning fewer problems with ash disposal and leakage of heavy metals. Replacement of old boilers with more modern ones can be expected to reduce emissions, despite the fact that fuel through-put will be almost doubled.

### **Investments and Operating Cost**

Depending on type of cogeneration, the investment cost ranges between 1,600USD/kW to 3,500 USD/kW installed. This can be easily proved by using the data available from one of our sugar factories in Tanzania, TPC in Kilimanjaro region. From the above, the cost for investment of a cogeneration plant of 13 MW is about 2,210 US\$/kW and that of 20.5 MW is about 1,730 US\$/kW.

### **Economic Instruments for Overcoming Barriers**

At macro-economic level, cogeneration can reduce the growth of national debt as well as improve the national balance of payments by reducing the import of fossil fuels. Unfortunately cogeneration was not given due attention in the past national policy and planning.

Co-generation can be increasing gradually, that is in modular manner. This may enable the projects to be financed locally. Also this could help to gain more experience from other factories within the region.

### **Advantages to Developing Countries**

Cogeneration can be implemented in rural areas with women participation. The sugar factories buy sugar cane from some surrounding small-scale producers. Both men and women may participate in growing this plant. They can be employed by sugar cane small scale producers in planting, weeding and harvesting the sugar cane plant. Also those with transport may be hired to transport cane to the factory. This increases the income to rural people. Such activities could reduce rural to urban migration.

## **Disadvantages to Developing Countries**

1. Deterioration of some equipment due to old age. This requires frequent replacement of some spare parts which means more expenditure in forex for the spares whose raw materials like stainless steel, are not locally available.
2. There is a shortage of forex to service high technology and very sophisticated equipment. This means there is a need to shop around for technological levels that are manageable within the region.
3. Non-availability of credit facilities in the country makes it difficult to set up more cogeneration systems.

## **Examples of Real Life Applications**

Kilombero Sugar Company  
Morogoro, Tanzania

Mtibwa Sugar Estate  
Morogoro, Tanzania

Bagasse Tanganyika Planting Company  
Kilimanjaro, Tanzania

Bagasse Kagera Sugar Company  
Kagera, Tanzania

Bagasse Sao Hill Saw Mill , Iringa, Tanzania

## **Sugar Mill Bagasse Boilers<sup>24</sup>** **Uganda, Commercial**

<b>Crop</b>	Sugarcane
<b>Residue</b>	Bagasse
<b>Process</b>	Combustion
<b>Equipment</b>	Bagasse Boiler
<b>Main Product</b>	Heat for sugar mill boilers

### **Production Capacity**

Bagasse (moisture content of 50-55% water, and this is also the moisture content of the cane when it is fed into the boiler. None of the sugar factories in Uganda predry the bagasse before it enters the boiler. The ash content varies from 2.5-6%, and the season of the year and techniques of harvesting are determining the ash content. If the harvesting is done in terms of mechanical loading, the ash content increases, and this is also happening in wet weather because more mud etc. is following the canes into the process (Polzin, 2004).

Currently (2004) there are four boilers installed at Kakira Sugar Works. They have the

following technical specifications:

- Boiler 1: 24 tons of steam per hour
- Boiler 2: 22 tons of steam per hour
- Boiler 3: 22 tons of steam per hour
- Boiler 4: 24 tons of steam per hour

The boilers are all operating at 20 bar pressure, and a combustion temperature at 300 °C.

A fifth boiler will be ready July 1st 2004, and it will be operated at 30 t MCR.

There are two turbines at Kakira:

- Turbo Alternator 1: 3 MW and 18 bar pressure. The water rate is at 11 kg/kW
- Turbo Alternatio 2: 1.5 MW and 18 bar pressure. The water rate: 13 kg/kW

The boilers at Kinyara have the following specifications:

- Boiler number 1: 35 tons of steam per hour at 2350 kPa and 350 °C
- Boiler number 2: 35 tons of steam per hour at 2350 kPa and 350 °C.

There are two turbines installed at Kinyara, and they have the following specifications.

They both have 1 MW steam driven back pressure Allen turbines. The pressure is 2350

---

<sup>24</sup> Lars Petter Bingham, NTHU, Opportunities for Utilizing Waste Biomass for Energy in Uganda, 2004

## Detailed Process Description

### Kakira Sugar Works

The boilers are constructed for bagasse combustion. The bagasse is gravity fed into the combustion chamber through chutes at the top of the boilers. The primary and secondary combustion air is entering the combustion chamber through ports in the furnace walls. The combustion starts where the bagasse hits the surface pile.

### Kinyara Sugar Works

Recently the boilers have been modified, and pinhole grates have been installed to improve the combustion process. These grates promote suspension firing of bagasse instead of pile burning which gives a much better heat release from the fuel (Jobling, 2004).

Generally the turbines are operated 46 weeks of the year. However, maintenance work is done to the machines every third week when they are turned off 16 hours each time. The turbines are operated at a load of 750 kW each. To handle peaks in the system there are diesel generating plants, which consist of one generator at 800 kW and one at 400 kW.

### Examples of Real Life Applications

Commercial

Karika Sugar Works  
Uganda

Commercial

Kinraya Sugar Works

Uganda

## **Brick Making<sup>25</sup> (Hoffman Kiln or Ring Kiln) Uganda, Commercial**

<b>Crop</b>	Coffee
<b>Residue</b>	Husk
<b>Process</b>	Combustion
<b>Equipment</b>	Ring Kiln
<b>Main Product</b>	Heat for drying

### **Production Capacity**

The dimensions of the kiln are quite large. Four of the chambers in the kiln are fired a day. The capacity of these four chambers are 2400 Maxpan blocks, 16 000 Mangolone tiles (roofing tiles) and 6000 Half bricks. The fuel consumption for this quantity is two 7 tons lorries filled with coffee husks. The exact capacity of these lorries are not measured, but estimated to 3-4 tons of coffee husks.

### **Detailed Process Description**

The Hoffmann kiln is constructed in a ring. The main purpose of this design is to make it possible to recover the heat from the flue gases in the combustion process. This design makes it possible to use the hot flue gas to preheat and dry the bricks before they enter the hottest parts of the kiln. In the post combustion phase, the heat from the finished bricks are preheating and drying the newly entered bricks (Nturanabo2, 2001). The kiln is divided into different chambers, and the combustion process is taking place in one of these chambers at time. There are channels connecting the chambers, where hot air and flue gases are transporting heat through the kiln. The kiln is fired by coffee husks. The husks are fed automatically into the kiln from wholes in the ceiling of the kiln. The rate of fuel entering the combustion chambers is regulated by measurements of the temperature inside the kiln.

When the feeders of coffee husks are moved to the next chamber, the temperature in that chamber is approximately 700 °C. Then, when the fuel starts pouring in, the temperature rises from 700 °C towards 900 °C which is reached after 1.5 or 2 hours. When the feeding of coffee husks is stopped, it takes around 1.5 to 2 hours before the temperature drops to 700 °C. When the combustion zone are moved further away, the temperature will decrease further from 700 °C and reach lower levels until around 100 °C when the bricks are ready to be removed from the kiln (Kayando, 2004). The kiln is emptied and filled up again opposite the combustion zone, because this area is the temperature is at its lowest. In this way, the combustion zone is moving constantly around in the kiln, and the combustion has lasted continuously since the kiln was opened.

---

<sup>25</sup> Lars Petter Bingham, NTHU, Opportunities for Utilizing Waste Biomass for Energy in Uganda, 2004

## Example of Real Life Applications

Commercial Use Hoffman Kiln  
Road, Uganda

Uganda Clays Ltd. Entebbe



Figure 11: The entrance to one of the chambers in the Hoffmann kiln at Uganda Clays can be seen to the left. The right picture is showing the wholes in the ceiling of the kiln used to feed coffee husks into the kiln.

### Coffee Husk Cement Kiln<sup>26</sup> Uganda, Commercial

<b>Crop</b>	Coffee
<b>Residue</b>	Husk
<b>Process</b>	Combustion
<b>Equipment</b>	Rotary Kiln
<b>Main Product</b>	Heat

#### Production Capacity

The consumption of coffee husks for that purpose is approximately 20 tons per day in 2003 (Norplan, 2003). No information is available on the number of operating days a year, but assumed that the factory produce 320 days (Kakira Sugar Works operates 320 days a year according to Polzin (2004)) a year, the total amount of coffee husks used is 6 400 tons.

---

<sup>26</sup> Lars Petter Bingham, NTHU, Opportunities for Utilizing Waste Biomass for Energy in Uganda, 2004

### **Detailed Process Description**

Hima cement is utilizing coffee husks in their production process. Cement is produced from limestone, which is crushed and grinded. The materials are calcinated in a rotary kiln, where the so called clinker is produced. The clinker is cooled until it is mixed with gypsum. When the cement is finished it is milled, stored and bagged. The coffee husks are used in preheating of the lime.

### **Examples of Real Life Applications**

Commercial

Hima Cement

Uganda



## **Aqueous Phase Reforming (APR)<sup>27</sup> USA, Commercial**

<b>Crop</b>	Corn
<b>Residue</b>	Syrup
<b>Process</b>	Gasification, Aqueous Steam Reforming
<b>Equipment</b>	
<b>Main Product</b>	Electricity

### **Technical Description of Technology**

The technology will be used for the first time to continuously produce electricity from a small 10-kilowatt generator at the company's facility in Madison. The unit is fueled by corn syrup, similar to the kind used by soft drinks manufacturers. The vast majority of hydrogen is currently made from fossil fuels -- oil, coal, and, most commonly, natural gas, through a process called steam reforming. In this process, a mixture of steam and methane is heated to temperatures above 800 degrees Celsius, and then reacts with a catalyst to produce hydrogen and carbon monoxide.

Although it's possible to use a similar process to generate hydrogen from biomass-derived ethanol, there are disadvantages in doing so. The high temperatures required and use of pressurized steam mean the conversion process only practical on the industrial scale. Virent's conversion process, which is called aqueous phase reforming (APR), avoids these problems by carrying out the reformation at relatively low temperatures and with liquids rather than steam. It means that there is no need to put as much energy into the system to make steam, and at the same time you're working with liquids, which have a higher energy density than gases for a given volume.

Furthermore, the process uses extremely active catalysts, which allow 15 times more hydrogen to be converted per gram of catalyst, compared with steam reforming. This efficiency allows 90 percent of the feedstock to be converted in the first cycle, and the rest to be recycled. As a result, Virent claims it's able to produce hydrogen for \$2-3 per kilogram -- competitive with natural-gas-derived hydrogen.

### **Examples of Real Life Applications**

The technology will be used for the first time (2005) to continuously produce electricity from a small 10-kilowatt generator at the company's facility in Madison.

---

<sup>27</sup> [http://www.technologyreview.com/read\\_article.aspx?id=16841](http://www.technologyreview.com/read_article.aspx?id=16841)

**Suppliers****Virent Energy Systems, Inc<sup>28</sup>.**

3571 Anderson Street

Madison , WI 53704

Phone:+1.608.663.0228

Fax: +1.608.663.1630

Email: [info@virent.com](mailto:info@virent.com)

Webmaster: [webmaster@virent.com](mailto:webmaster@virent.com)

---

<sup>28</sup> <http://www.virent.com/ContactUs/contactus.html>

## Shelled Corn as Fuel<sup>29</sup> USA, Commercial

<b>Crop</b>	Corn
<b>Residue</b>	Shelled Corn
<b>Process</b>	Combustion
<b>Equipment</b>	Stoves and boilers
<b>Main Product</b>	Heat

### Technical Description of Technology

Burning shelled corn as a fuel can be a feasible way of dealing with the high prices of more conventional fuels such as fuel oil, propane, natural gas, coal, and firewood. Utilizing corn as a fuel does not compete with the food supply needed for nourishment throughout the world. While it is recognized that malnutrition is a serious global problem, the world is not experiencing a food production problem. Instead the world faces political challenges associated with providing infrastructure systems for food distribution and storage.

Contemporary agricultural systems can produce sufficient quality and quantity of food for the world's population, with additional resources available so that agricultural products can be used as fuel, pharmaceuticals, and chemical feedstocks.

### Additional Information

[Heat Energy Content of Shelled Corn](#) — The combustion energy content of shelled corn is a critical factor in making energy comparisons of fuels.

[Corn Energy Equivalents](#) — This table provides a method of calculating how much shelled corn would be required to replace the fuel currently being used for heating.

[EnergySelector](#) — EnergySelector is a user-friendly decision-aide to easily compare the heating values available from any two energy sources.

[Shopping for a Corn-Burning Stove?](#) — Questions to ask when considering the purchase of a corn-burning stove.

[Locating a Supplier of Shelled Corn](#) — Do not purchase a corn-burning stove without first identifying a reliable supplier of shelled corn.

[Quality of Shelled Corn](#) — For best results, the quality of shelled corn burned in a corn-burning stove must be specified.

[Storage Requirements of Shelled Corn](#) — Proper storage of shelled corn is important for good performance of a corn-burning stove.

[Disposal of Corn Ash](#) — A plan for the proper disposal of corn ash needs to be developed before purchasing a corn-burning stove.

---

<sup>29</sup> <http://burncorn.cas.psu.edu/>



### **Environmental Considerations**

Shelled corn is a fuel that can be produced within 180 days, compared to the millennia needed to produce fossil fuels.

### **Suppliers**

For more information please contact:

Dennis Buffington  
Professor of Agricultural and Biological Engineering  
Penn State University  
Email: [dbuffington@psu.edu](mailto:dbuffington@psu.edu)  
814-865-2971 (Voice)  
814-863-1031 (FAX)

MANUFACTURERS OF CORN-BURNING STOVES AND BOILERS

### **FOR RESIDENTIAL APPLICATIONS**

Alternate Energy Solutions/Sedore Stoves USA  
47909 County Road 37  
Deer River, Minnesota 56636  
218-246-2908  
<http://www.sedoreusa.com>

Amaizablaze/Nesco, Inc.  
P. O. Box 3498  
Cookeville, TN 38502  
931-372-0130  
<http://www.cornstoves.info>

American Energy Systems, Inc.  
150 Michigan Street SE  
Hutchinson, MN 55350  
800-495-3196  
<http://www.hearthdirect.com>

America's Heat/LMF Mfg.  
601 Woods Avenue  
Lock Haven, PA 17745  
800-582-4317  
<http://www.americasheat.com>

Big M Manufacturing Co.  
Box 319A  
928 East 1090 N. Road  
Taylorville, IL 62568  
217-824-9372 Bixby Energy  
9300 75th Avenue North  
Minneapolis, MN 55428  
877-500-2800  
<http://www.bixbyenergy.com>

CANECO Manufacturing Inc.  
Box 9042, Sub.40  
London, ON  
N6E 1V0 Canada  
519-686-7298  
<http://www.cornstove.ca>

CornGlo Industries, LLC  
P.O. Box 548  
3990 Highway 25E  
Beanstation, TN 37708  
865-993-4436  
[www.cornnglo.com](http://www.cornnglo.com)

Corn King Furnaces  
3332 Hosner Rd.  
Dryden, Michigan 48428  
810-796-9805  
<http://www.cornkingfurnaces.com/>

Country Flame Technologies, Inc.  
1200 E. Industrial Park Drive  
Mt. Vernon, MO 65712  
417-466-7161  
<http://www.countryflame.com>

**Dansons Group, Inc.**  
26319 Township Road 531  
Acheson, Alberta  
Canada T7X 5A3  
877-303-3135  
<http://www.dansons.com>

**Eagle Manufacturing, Inc.**  
1120 East 2nd Street  
Webster City, IA 50595  
515-832-4655  
<http://www.eaglemfginc.com>

**Fahrenheit Technologies, Inc.**  
526 East 64th Street  
Holland, MI 49423  
616-392-7410  
<http://www.fahrenheittech.com>

Golden Grain Corn Stove  
P.O. Box 5000  
Sterling, CO 80751  
800-634-6097  
<http://www.goldengrainstove.com>

Grain Stoves, Inc.  
R.R. 3  
Blyth, Ontario  
Canada NOM 1HO  
519-523-9897  
<http://www.grainstovesinc.com>

Harman Stove Company  
352 Mountain House Road  
Halifax, PA 17032  
717-362-1422  
<http://harmanstoves.com>

HS-Tarm  
5 Main Street, P.O. Box 285  
Lyme, NH 03768  
800-782-9927  
<http://www.pelletboiler.com>

Ja-Ran Enterprises, Inc.  
3541 Babcock Road  
Lexington, MI 48450  
810-359-7985  
<http://www.ja-ran.com>

K-C Cornburners, Inc.  
1433 Northstar Drive  
Zumbrota, MN 55992  
507-732-4666  
<http://kccornburners.com>

Kernelburner  
46304 Jeffery Street  
Hartford, SD 57033  
605-528-4700  
<http://www.kernelburner.com>

Kozy Heat Fireplaces  
204 Industrial Park Drive  
Lakefield, MN 56150  
800-253-4904  
[www.kozyheat.com](http://www.kozyheat.com)

LDJ Manufacturing  
1833 Hwy 163  
Pella, IA 50219  
866-535-7667  
<http://www.ldj-products.com>

Lennox Hearth Products  
1110 West Taft Avenue  
Orange, CA 92865  
714-921-6100  
<http://www.earthstove.com>

Pinnacle Stove Sales, Inc.  
1089 Highway 97 North  
Quesnel, B. C.  
Canada V2J 2Y3  
250-992-5050  
<http://www.pinnaclestove.com>

Quadra-Fire  
Hearth & Home Technologies  
1445 North Highway  
Colville, WA 99114-2008  
<http://www.quadrafire.com>

RJM Manufacturing, Inc.  
1875 Olson Drive  
Chippewa Falls, WI 54729  
715-720-1794  
<http://www.energyking.com>

SAR Biomass Energy Systems LLC  
P.O. Box 203  
Pocahontas IA, 50574  
712-335-4616  
[www.sarcornfurnace.com](http://www.sarcornfurnace.com)

Sedore Multi-Fuel Stoves and Furnaces  
P. O. Box 103  
Oro, Ontario L0L 2X0  
705-487-1921  
<http://www.sedoremultifuelstoves.com>

Snow Flame, Inc.  
4076 Haywood Road  
Mills River, NC 28742  
828-891-1006  
<http://www.snowflame.com>

Thor Manufacturing LLC  
1460 Timber Avenue  
Hansell, IA 50441  
641-257-4220  
<http://www.thorfrostbuster.com>

United States Stove Company  
108 Garner Road  
Bridgeport, AL 35740  
423-837-2100  
<http://www.usstove.com>

**MANUFACTURERS OF CORN-BURNING STOVES AND BOILERS  
FOR COMMERCIAL APPLICATIONS  
(100,000 TO 500,000 BTU/HOUR)**

America's Heat/LMF Mfg.  
601 Woods Avenue



Lock Haven, PA 17745  
800-582-4317  
<http://www.americasheat.com>

Big M Manufacturing Co.  
(A-Maize-Ing Heat)  
Box 319A  
928 East 1090 N. Road  
Taylorville, IL 62568  
217-824-9372

**Corn King Furnaces**  
3332 Hosner Rd.  
Dryden, Michigan 48428  
(810) 627-9646  
<http://www.thecornfurnace.com>

**Eagle Manufacturing, Inc.**  
1120 East 2nd Street  
Webster City, IA 50595  
515-832-4655  
<http://www.eaglemfqinc.com>

Golden Grain Corn Stove  
P.O. Box 5000  
Sterling, CO 80751  
800-634-6097  
<http://www.goldengrainstove.com>

HS-Tarm  
5 Main Street, P.O. Box 285  
Lyme, NH 03768  
800-782-9927  
<http://www.pelletboiler.com>

Ja-Ran Enterprises, Inc.  
3541 Babcock Road  
Lexington, MI 48450  
810-359-7985  
<http://www.ja-ran.com>

K-C Cornburners, Inc.  
1433 Northstar Drive  
Zumbrota, MN 55992  
507-732-4666  
<http://kccornburners.com>

Kernelburner  
25198 421st Ave.

Alexandria, SD 57311  
605-239-4690  
<http://www.kernelburner.com>

LDJ Manufacturing  
1833 Hwy 163  
Pella, IA 50219  
866-535-7667  
<http://www.ldj-products.com>

Pinnacle Stove Sales, Inc.  
1089 Highway 97 North  
Quesnel, B. C.  
Canada V2J 2Y3  
250-992-5050  
<http://www.pinnaclestove.com>

Quality Manitoban Products  
Box 398  
Morris, MB Canada  
204-746-6894  
<http://www.topline-dist.com>

RJM Manufacturing, Inc.  
1875 Olson Drive  
Chippewa Falls, WI 54729  
715-720-1794  
<http://www.energyking.com>

SAR Biomass Energy Systems LLC  
P.O. Box 203  
Pocahontas IA, 50574  
712-335-4616  
[www.sarcornfurnace.com](http://www.sarcornfurnace.com)

Solagen  
33993 Lawrence Road  
Deer Island, OR 97054  
503-366-4210  
<http://www.solageninc.com>

**Thor Manufacturing LLC**  
1460 Timber Avenue  
Hansell, IA 50441  
641-257-4220  
<http://www.thorfrostbuster.com>

**Year-A-Round Corporation**  
110 West Lind Street

P.O. Box 2075, Mankato, MN 56002  
800-418-9390  
<http://www.year-a-round.com>

MANUFACTURERS OF CORN-BURNING STOVES AND BOILERS

**FOR INDUSTRIAL APPLICATIONS**  
(500,000 BTU/HOUR AND LARGER)

Advanced Recycling Equipment, Inc.  
850 Washington Road  
St. Marys, PA 15857  
800-611-6599  
<http://advancedrecyclingequip.com>

RIMACO  
P. O. Box 41  
Beavertown, PA 17813  
570-658-7491  
<http://www.ricemachineryco.com>

SAR Biomass Energy Systems LLC  
P.O. Box 203  
Pocahontas IA, 50574  
712-335-4616  
[www.sarcornfurnace.com](http://www.sarcornfurnace.com)

Smart Building Products  
1658 Route 300  
Newburgh, NY 12550  
Ph:845-566-9329  
<http://www.smartbuildingproducts.com>

**Year-A-Round Corporation**  
110 West Lind Street  
P.O. Box 2075  
Mankato, MN 56002  
800-418-9390  
<http://www.year-a-round.com>

## **Carbon Diversion Flash Carbonization System USA, Commercial**

<b>Crop</b>	Corn, garden and tree trimmings etc.
<b>Residue</b>	Corn cobs and stover, trimmings
<b>Process</b>	Flash Carbonization
<b>Equipment</b>	Transportable reactor system
<b>Main Product</b>	Carbon and electricity

### **Main Raw Materials Used:** <sup>30</sup>

#### Green Waste

1. Urban tree Trimming
2. Household Garden Trimming
3. Landscape Trimming

#### Agricultural Waste

1. Corn cobs and corn stover
2. Manures

#### Logging and Mill Products

#### Food Processing Waste

#### Waste Hydrocarbons

#### Special Waste such as medical waste

### **Technical Description of Technology:**

The system reactor converts waste materials into valuable products: carbon and electricity. A typical installation consists of two to four reactors, each capable of handling a one-ton load an hour. Two people staff this installation. One person loads and unloads the containers that fit into the reactor while the other person operates the reactor. A carbon diversion system requires ½ acre of land. This includes room to store materials to be processed, the reactor and its associated equipment, loading containers and bin to store carbon.

### **Detailed Process Descriptions:**

To begin the Flash Carbonization process, biomass is loaded with a crane and packed into a vertical reactor chamber. The chamber is sealed and a flash fire is ignited at the base of the chamber. Heat released by the fire triggers the transformation of biomass into charcoal, sped up by a continuous flow of oxygen being pumped into the sealed reactor. Many organic materials as well as tires and biomedical waste can substitute wood and other forms of biomass.

### **Main Products:** Charcoal Briquettes<sup>31</sup>

---

<sup>30</sup> <http://www.carbondiversion.com/>

<sup>31</sup> <http://www.world-wire.com/news/0606190001.html>

The result is wood (biomass) can be converted into charcoal as quickly as 30 minutes, not 3 to 10 days, and has 200% more energy value than current commercial technologies.

### **Operation and Maintenance Requirements:**

The reactor used in the Flash Carbonization process stands nine feet tall, three feet in diameter and requires only a ½ acre for operations. Unlike larger refineries, these reactors are easily transported, have lower capital requirements and are neighborhood friendly to serve small and rural communities. The reactors systems are simple to use, requiring a minimum of two on-site operators.

### **Social Considerations<sup>32</sup>**

The technology is an ideal solution as a renewable energy source in developing countries and is a needed recycling system for industrialized nations (green waste in the United States accounts for 1/3 of the waste stream and emits green house emissions when it decomposes).

### **Investments and Operating Cost<sup>33</sup>**

The University of Hawaii developed the technology in 2001 with money provided by the federal government, the University and the private sector. More than \$2 million was spent developing the patented technology, which also is licensed to Pacific Carbon and Graphite LLC and Waipahu-based Carbon Diversion Inc. Carbon Diversion, which has exclusive rights to manufacture charcoal using the UH process here in Hawai'i and other parts of the Pacific basin, said it recently landed its largest investment — \$2 million — which will be used to build eight charcoal production units in Kapolei.

### **Advantages to Developing Countries<sup>34</sup>**

Carbon Diversion, situated in Hawaii, is in an extremely strategic position to service partners in North America as well as Pacific Rim Countries including Asia, Australia and the smaller Countries of the Pacific Basin. The reactor and entire system have been designed to be portable and scalable – there is a mobile model for developing communities that is mounted on a truck and

driven around from one village to the next. As part of a dedication to bring the technology to the greatest number of markets, the company's strategy is to lease the technology to partners thereby reducing the upfront capital investment.

### **Examples of Real Life Applications**

Campbell Industrial Park Kapolei, Oahu, Hawaii

---

<sup>32</sup> <http://www.lohas.com/articles/81547.html>

<sup>33</sup> <http://the.honoluluadvertiser.com/article/2007/Jul/28/In/hawaii707280348.html>

<sup>34</sup> <http://www.world-wire.com/news/0606190001.html>

**Suppliers:**

Michael Lurvey, CEO  
Carbon Diversion, Inc.  
94-1031 B Maiiau Street  
Waipahu, Hawai'i 96796  
Phone/Fax: 808-671-1858  
lurvey@carbondiversion.com  
<http://www.carbondiversion.com>

## Biomass Heating System<sup>35</sup> UK, Commercial

<b>Crop</b>	Wheat, oats and barley
<b>Residue</b>	Dry biomass waste
<b>Process</b>	Combustion
<b>Equipment</b>	Biomass Boilers
<b>Main Product</b>	Heat and steam

### Production Capacity

High quality automatic wood-fuel boilers can operate between 20% and 100% of their maximum continuous rating (MCR) without a serious loss of efficiency. This enables a single boiler to be operated over a range of outputs and follow the heat demand more closely.

### Detailed Process Description

Biomass heating systems are typically designed to replace either oil or gas fired boilers. Due to the nature of biomass fuels the boilers tend to be physically larger than those for oil or gas, they require more space and need to be located in a position that is easily accessible to fuel delivery vehicles. All automatic biomass-fired boiler plants are essentially similar, consisting of four key elements: Fuel storage, fuel feed mechanism, grate or hearth and heat exchanger.

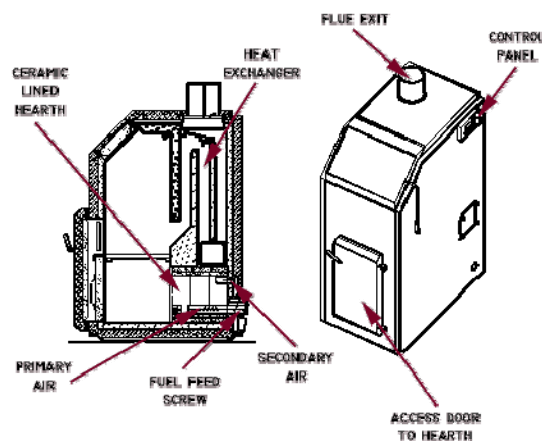

Typical KSM Domestic Boiler Features

### Operation and Maintenance Requirements

- Computer controlled for optimum efficiency and are easy to maintain and operate

<sup>35</sup> [http://www.asgard-biomass.co.uk/biomass\\_heating.php](http://www.asgard-biomass.co.uk/biomass_heating.php)

- Maintenance and operating procedures are similar to oil or gas boilers with the exception of some cleaning every one or two months

Wood combustion produces about 0.5 – 1.5% by weight of ash depending on fuel quality. This ash collects in an ash pan under the grate. It has to be removed manually in regular intervals depending upon heating demand. Automatic de-ash systems into a large ash bin (see Figure 7) reduce the amount of work required but the ashbin still requires removal and emptying periodically. This ash is safe for use as a soil fertilizer. It should be noted that all KSM boilers are fitted with automatic de-ash as standard. Boilers that incorporate cyclone separators trap minute particles passing through the boiler. Depending upon the operating conditions these separators will need cleaning every three to six months. For manually operated boilers the boilerplates and tubes will need to be scraped clean every six months to a year. Chimney flues will collect deposits of the tar and soot depending upon operating conditions. It is therefore advised that flues are checked annually and swept clean as necessary, which may be once a year or every two years. Motor and auger bearings need checking twice every year and greased according to the manufacturers specifications.

### **Environmental Considerations**

- Subject to Pollution Prevention and Control Regulations 2000 (PPC)
- Installation uses the Best Available Techniques (BAT) in the design and operation of the plant to prevent pollution

### **Institutional and Regulatory Consideration or Requirements**

- Subject to both the Waste Incineration Directive (WID) and the Pollution Prevention and Control Regulations 2000 (PPC)

The WID applies to all incineration and co-incineration plants. Co-incineration includes installations where waste is used as a fuel where energy generation is the main purpose.

All co-incinerators that fall within the WID are also subject to control under the PPC. Larger plant will be regulated by the Environment Agency under Part A (1) of Section 5.1 and smaller plant will be regulated by the local authority under Part A(2) of Section 5.1. Part A(2) applies to plant burning non-hazardous waste with a capacity of less than 1 Tonne per hour.

If a plant or 'installation' comes under the PPC Regulations then there must be an application made to operate such a facility.

### **Examples of Real Life Applications**

Commercial use Biomass Heating System Unit 20, The Acorn Centre, Chestnut Ave., Biggleswade, Beds, SG18 0ra



## Supplier

R.D. Associates, Ltd.

## Fuel Delivery and Storage

Fuel is either supplied by an external contractor or as a self-supply operation, for example a farm or estate with its own wood harvesting operation. There are a number of mechanisms to deliver the fuel to the bunker. The simplest option is to tip the chips or pellets directly from a tipper truck or trailer into a subterranean bunker. Other options include dump bag systems, front-end loaders; purpose built containers, or pneumatic delivery. The options for fuel delivery and storage are mostly determined by the position of the boiler and the access to the premises being heated. The fuel delivery and storage system can account for a large proportion of the overall cost of installing biomass-heating systems. In new building applications, consideration to the location and operation of a biomass boiler and store should be undertaken as early as possible to avoid additional costs in the future.



Figure 2: Fuel Delivery  
(tanker picture kindly supplied by [The Energy Crops Company Ltd.](http://www.energy-crops.com))

## Fuel feed systems

Biomass fuels such as woodchip and oilseed cake are not free flowing materials and have a tendency to bridge, and so storage bunkers, or silos, are fitted with some type of agitator system. Small systems use rotating sweeper arm devices that drag the material over an auger as shown below.



Figure 3: Typical Sweeping Floor System

Larger woodchip storage systems require moving floors that move the material to an auger placed at the end of the bunker.

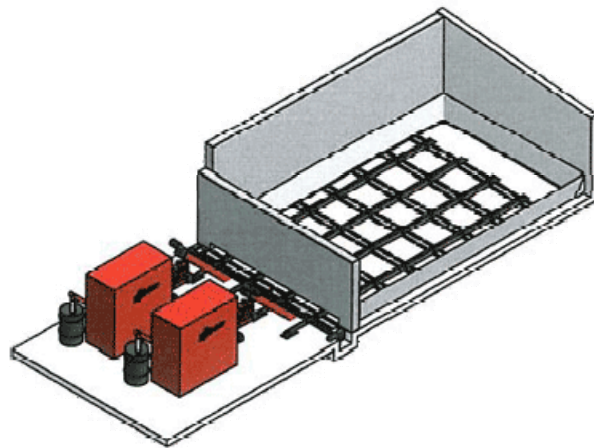

4: Typical Moving Floor System

Wood pellets flow very easily and do not need special agitator systems. The fuel is removed from the store by an auger, which lifts the fuel and deposits it in a drop cell, which has three key functions:

- It prevents air being drawn into the boiler
- It measures the woodchips being fed onto the boiler stoker conveyor
- It assists in preventing burn back from the boiler

The precise arrangements of the drop cell vary with individual suppliers. The KSM unit is shown in Figure 5.



Figure 5: KSM Drop Cell Unit

Some of the smaller, simple woodchip systems units may dispense with the drop cell and use a single short auger to feed fuel directly to the burner.

### **Grate (Hearth)**

Comprises a short auger that feeds the fuel directly into the combustion zone. The type and design of the grate varies between individual manufactures. 'Underfed grates', as used in KSM boilers, are typically used with wood-fuels with moisture contents of 30% or less, 'Overfed grates' are used for small wood pellet burners and 'Moving step grates' are used for fuels with moisture contents of 30% to 60%.

Wood requires relatively little primary air (air supplied at the point of solids combustion, usually under the grate) but requires a good supply of secondary air (over-grate) to ensure that complete combustion takes place. All modern woodchip and wood pellet burners have provision for separate

control of the primary and secondary air supply, in order that combustion can be properly balanced. The combustion zone is usually insulated and comprises a primary and secondary chamber to ensure thorough mixing (turbulence) and time for the combustion reactions to occur.

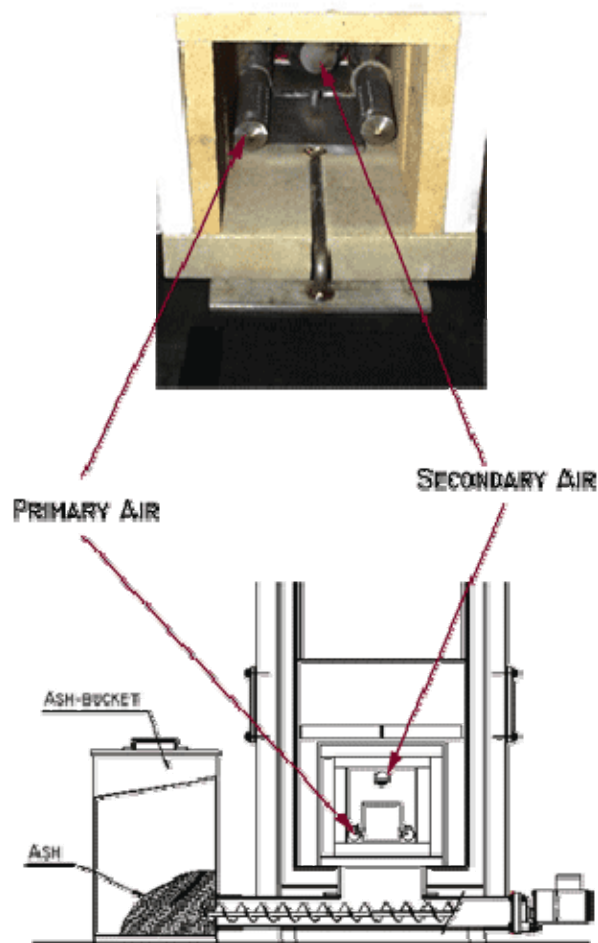

Figure 6: Typical KSM Hearth

Boilers are fitted with a number of control features. The inlet, outlet and room temperatures are monitored and linked to sensors that control the feed auger and determine the rate that fuel is supplied to the combustion zone. Sensors in the exhaust, monitoring oxygen and carbon monoxide levels (lambda sensors), are used to regulate the air supply and/or the fuel feed to maintain the correct air to fuel ratio for clean combustion and low emissions. In general wood fuel is a low sulphur fuel but has higher NO<sub>x</sub> emissions than gas or oil boilers due to the inherent high nitrogen content of the fuel.

### Heat Exchanger

These are conventional heat exchangers similar to those used for gas or oil fired boiler systems. They comprise either a simple water jacket or multi-pass fire tube positioned either horizontally or vertical. The boilers are highly efficient with typical efficiencies of 80% to over 90% for woodchip and wood pellet systems.

**It should be noted that the KSM range of boilers have efficiencies of over 90%.**

There is a tendency for fly ash to accumulate in the fire tubes, especially those set in a horizontal position, which then require cleaning at regular intervals dependent upon the fuel quality. A number of manufactures now offer automatic tube cleaning for larger boiler plant as a standard feature. This is recommended for ensuring high efficiencies and low maintenance costs. The larger systems are also fitted with cyclone separators to collect any fly ash passing through the boilers and into the environment.

Many boilers are also fitted with flue gas recirculation, which helps to control combustion temperatures and reduce NO<sub>x</sub> formation.

## **Bio-oil from Forest Waste Canada, Commercial**

<b>Crop</b>	Forest products
<b>Residue</b>	Forest waste
<b>Process</b>	Bio-refinery
<b>Equipment</b>	Transportable bio-refinery plant
<b>Main Product</b>	Heat and electricity
<b>By-Product</b>	Plastics and glues

### **Technical Description of Technology**

To promote a more diverse and sustainable supply of electricity in the future, the Ontario government is building a bio-refinery to convert forest waste to bio-oil.

The transportable bio-refinery plant will convert unused forest waste into a bio-oil that can be used as fuel. The \$771,000 investment is part of ReNew Ontario, the McGuinty government's strategic five-year, \$30-billion infrastructure investment plan.

Under a three-year partnership with Advanced BioRefinery, the transportable bio-refinery plant will convert unused forest waste into a bio-oil that can be used as fuel to provide heat and electricity, and to make byproducts such as plastics and glues.

A sustainable supply of unused forest waste or biomass is available in Ontario's forests, such as tree tops, limbs and waste left after logging operations; trees destroyed by fire, insects and disease; and logs that can't be sold.

### **Investment Cost**

\$771,000 investment

### **Example of Real Life Applications**

Toronto, Ontario, Canada

### **Supplier**

Advanced Biorefinery Inc  
1391 Normandy cres. Ottawa, Ontario K2C 0N4  
Peter Fransham, pfransham@advbiorefineryinc.ca

**AgriPower<sup>36</sup>**  
**USA, Commercial**

<b>Crop</b>	Mixed crops
<b>Residue</b>	Crop residue
<b>Process</b>	Combustion, "open" Brayton cycle
<b>Equipment</b>	Fluid bed combustor and several heat exchangers
<b>Main Product</b>	Electricity and heat
<b>By-Product</b>	Hot air

**Technical Description of Technology**

AgriPower is an energy conversion technology fueled with biomass to produce electricity and heat energy. The system operates with an "open" Brayton cycle using a fluid bed combustor and several heat exchangers to heat compressed air that in turn drives a turbine generator set.

**Value-Added Product - Hot Air**

The system discharges clean hot air that can be used for cogeneration. This supply of clean hot air (500 degree) is a value-added product that can be used for absorption chilling, ice making, food processing, etc. Also, the flue gas is available for fuel drying.

**Modular and Transportable**

The size and modularity adds economy to both the manufacturing process and the operation and maintenance. This project's concept of on-site energy production limits or eliminates the normal biomass risks and uncertainties regarding biomass feedstock price, quantity, timing of delivery, transportation, storage and handling costs.

---

<sup>36</sup> <http://www.agripowerinc.com/renewables.html>

## Examples of Real Life Applications



### Supplier

MPR ASSOCIATES, INC. | 320 KING STREET | ALEXANDRIA | VIRGINIA |  
22314-3230 | **PHONE 703.519.0200** | FAX 703.519.0224

AGRIPOWER INC | 11428 ELKS CIRCLE | RANCHO CORDOVA | CA |  
95742 | **PHONE 650 941-4131** | FAX 650 941-4134



**BioMax 25<sup>37</sup>**  
**USA, Commercial**

<b>Crop</b>	Woods, nutshells, pellets, corn, grasses
<b>Residue</b>	Sawdust, rice husks, leaves
<b>Process</b>	Gasification, polygeneration system
<b>Equipment</b>	Biomax 25 Gasifier
<b>Main Product</b>	Electricity and thermal application for lumber drying

**Technical Description of Technology**

System Hardware (25 kW) – 300 sq. ft. max

Biomass Storage Area- determined by the user

24/6 operation: ~1.2 MWhe/day + 12 MM Btu/day – greater control of gasifier, automatic char and ash extraction, continuous dry filtration

**Detailed Process Description**

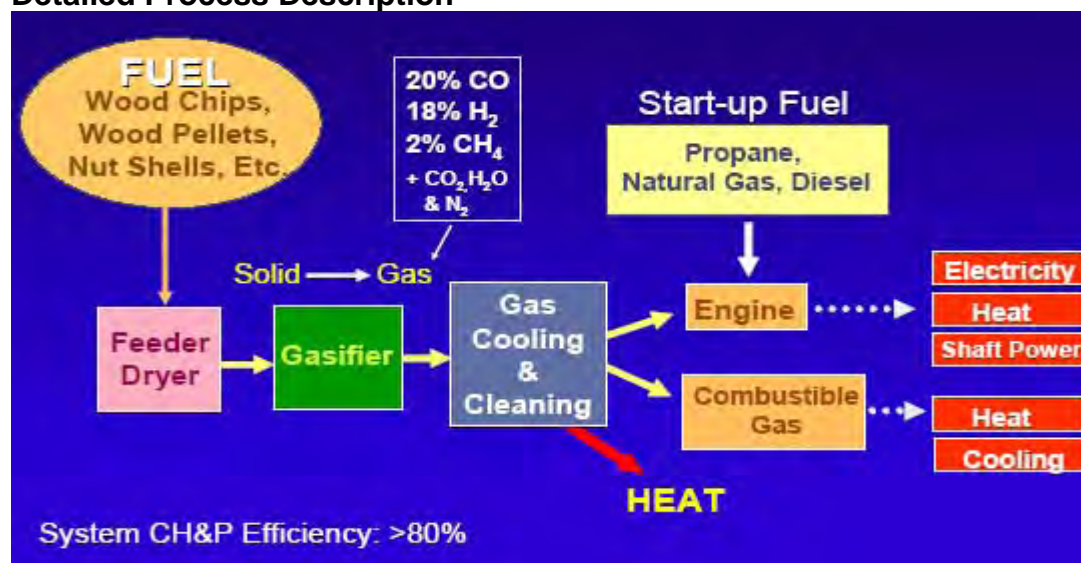

**Drying Capacity** 93,500 board foot capacity, Primarily softwood

**Operation and Maintenance Requirements**

**Biomass Required:**

~ 2 lb will yield 1 kWhe + 2 kWht

50 dry lb/hr for 25 kW BioMax

**Manpower:**

<sup>37</sup> [www.gocpc.com](http://www.gocpc.com)

The system does not need a full time operator but requires part time attendant duties to handle:

Start and stop system, replenishment of biomass, inspection and maintenance, respond to alarms.

**Maintenance Requirements:**

Filter and Oil Change, Cleaning of ash hopper once a week, Inspection of gasifier internals once per month to remove tramp materials.

**Environmental Considerations**

BioMax meets current CARB (California Air Quality Resources Board Standards for distributed Power and Heat) standards. No water, no smoke, no smell, no harmful effluents. The waste stream neither exhibits hazardous waste characteristics, nor it is a listed hazardous waste. Emits dry ash.

**GHG Emission Reduction Potential**

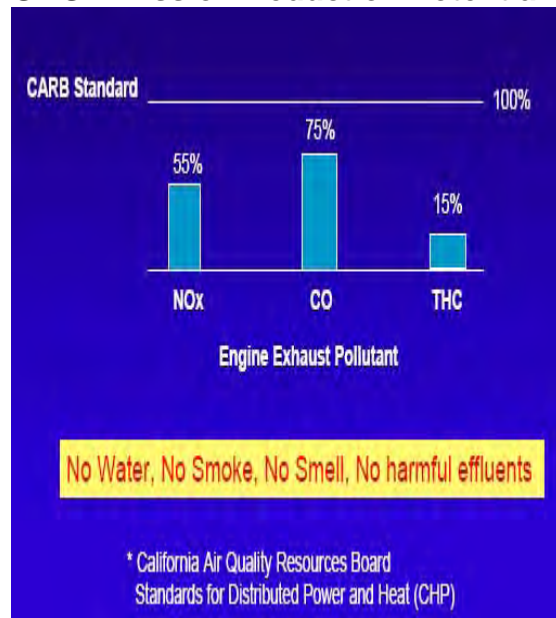

**Example of Real Life Applications**

Commercial Application BioMax 25 Corporation,

Community Power

Colorado, U.S. A.

**Supplier**

Community Power Corporation, 8110 Shaffer Parkway, Littleton Colorado, USA.

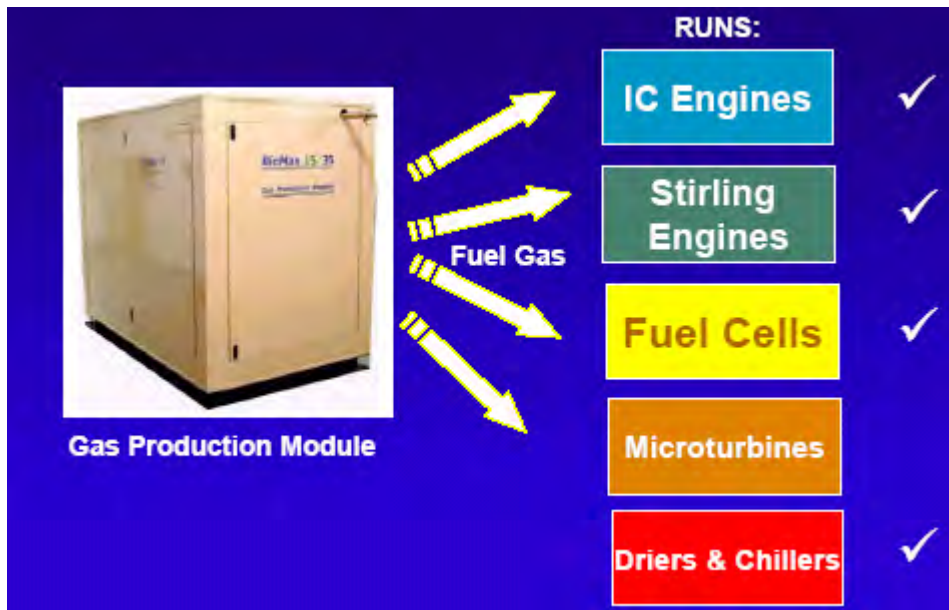

## **Brompton Mill Cogeneration Plant<sup>38</sup> Canada, Commercial**

<b>Crop</b>	Wood, etc.
<b>Residue</b>	Paper mill sludge, bark and other wood residues
<b>Process</b>	Combustion
<b>Equipment</b>	Boiler, steam turbine
<b>Main Product</b>	100 MW of electricity

### **Technical Description of Technology**

The project will be completed in two stages. The first will entail the installation of a boiler to burn paper mill sludge, bark and other wood residues. In the second phase, a steam turbine will be installed downstream from the boiler to generate electricity and supply the steam required for mill operations. The company plans to take the necessary measures to mitigate noise, odor, steam, and visual impacts caused by daily operations for residents living nearby.

### **Job Potential**

Almost 500 jobs

### **Environmental Considerations**

Environmental benefits include an annual reduction in greenhouse gases equivalent to removing 18,000 vehicles from the road; reduction in future landfilling of paper mill sludge, bark, and particle waste; reduction in the risk of leachate contamination as a result of reduced landfilling of bark; reduction in fossil fuel consumption; and an overall improvement in air quality.

### **Investment and Operating Cost**

\$85-million investment

### **GHG Emission Reduction Potential**

Annual reduction in greenhouse gases equivalent to removing 18,000 vehicles from the road

### **Example of Real Life Applications**

2005 construction of its 23 MW biomass cogeneration plant in the company's Brompton mill, located in the Eastern Townships of Quebec. The plant will supply 100 MW of electricity generated from biomass.

### **Suppliers**

Kruger's Energy Group

---

<sup>38</sup> <http://www.renewableenergyaccess.com/rea/news/story?id=35103>

## Solar-Biomass Hybrid Cabinet Dryer<sup>39</sup> Thailand, Commercial

<b>Crop</b>	Rice, wood, coconut
<b>Residue</b>	Rice husk briquettes, wood chips, coconut shells
<b>Auxiliary Materials</b>	Solar PV
<b>Process</b>	Gasification
<b>Equipment</b>	Solar-biomass hybrid cabinet dryer
<b>Main Product</b>	Heat for drying

### Technical Description of Technology

Small-scale drying based on electricity, coal, LPG and other fossil fuels is normally expensive. Moreover, combustion of fossil fuels emits greenhouse and other gases. Solar drying is an attractive option to solve some of these problems. However, an inherent problem of solar drying is that it depends entirely on the weather and is not possible to use during nighttime. A hybrid cabinet dryer with an automatic temperature control mechanism has been developed at Asian Institute of Technology (AIT), Thailand for drying agricultural products. The hybrid pairs a domestic gasifier stove (DGS), developed at AIT, and a flat plate solar air heater to supply hot air for drying products inside a cabinet. The technical specifications of the dryer are presented in Table 2.1.

### Size of Machine/ Production Capacity

Table 2.1: Technical specifications of solar-biomass hybrid cabinet dryer

Sl. No. Parameter	Specifications
1. Solar Collector type	Flat plate air-heating solar collector
2. Solar Collector size	2m x 2m
3. Drying chamber dimensions (height)	2m (length) x 2m (breadth) x 1.95m
4. Drying chamber construction	Bricks and mortar
5. No. of trays	16 nos.
6. Total tray area	14 m <sup>2</sup>
7. No. of doors for loading/	unloading 4 nos., two at each side
8. Stove type	Natural convection cross-flow gasifier stove

<sup>39</sup> <http://www.retsasia.ait.ac.th/booklets/Dissemination%20Booklets-Phase%20III/Tech%20pack-Dry-low%20resl.pdf>

- |                                       |  |
|---------------------------------------|--|
| 9. Gasifier stove capacity            | 4.5 kW (thermal)                           |
| 10. Fuel for gasifier stove           | Wood chips, wood twigs, briquette pieces   |
| 11. Heat exchanger type               | Pipe heat exchanger                        |
| 12. Airflow inside the drying chamber | Natural convection, with chimneys          |
| 13. Temperature controller            | Thermostat-based, mechanical lever control |

**Design Details**

***Drying Chamber***

The drying chamber is 2m x 2m in cross-section and has a height of 1.95m. The foundation is made of 1m deep concrete pile. Figures 2.1, 2.2 and 2.3 illustrate the dryer. The drying chamber has brick walls on all four sides. The doors, as shown in Figure 2.3, were made of two layers of G.I. sheet with fiberglass insulation in between to reduce the heat loss; a narrow transparent area allows viewing of the products from outside during drying (Figure 2.1)

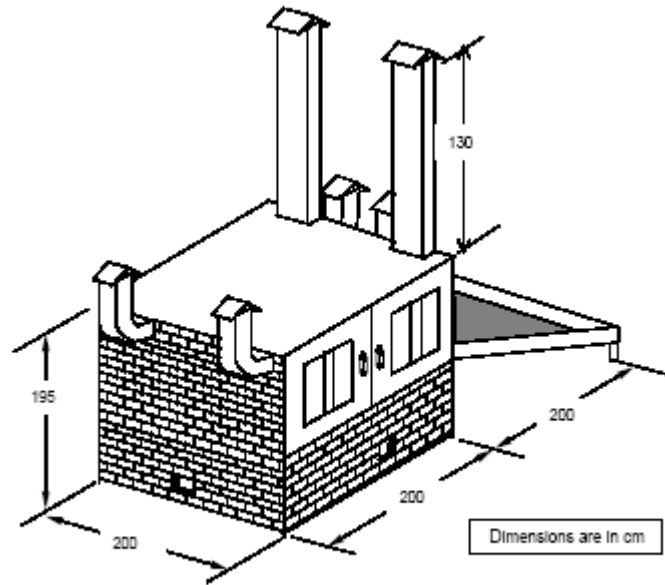

*Figure 2.1: Configuration of the drying chamber*



*Figure 2.2 Solar-biomass hybrid cabinet dryer*

Two doors were designed for easy loading and unloading of the products. There are four process air outlets from the drying chamber; the outlet air flow can be adjusted by slide plates to partially close these outlet openings. The product to be dried can be loaded inside the dryer at four levels. Each level has four trays (Figure 2.3).



Figure 2.3: Inside view of the drying chamber

### **Gasifier Stove**

The gasifier-gas burner component of the stove (Figure 2.4) consists of four main parts – fuel chamber, reaction chamber, primary air inlet and combustion chamber; these parts are assembled using bolts and nuts.

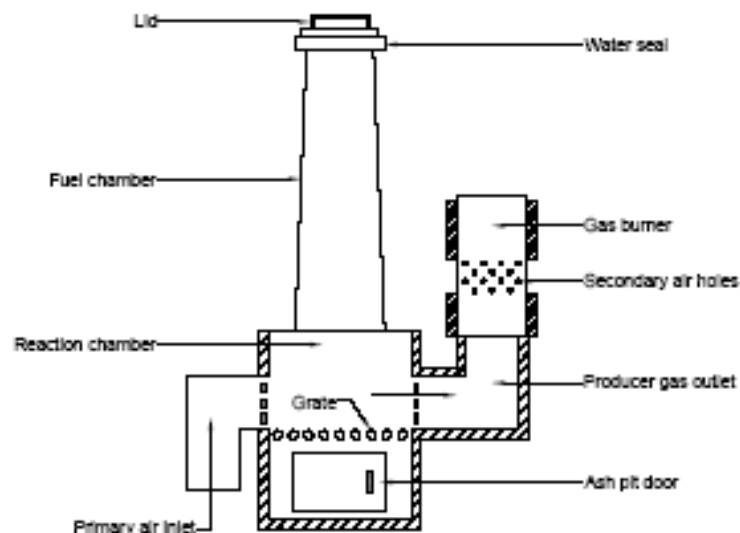

Figure 2.4: Schematic diagram of the domestic gasifier stove DGS2

A photograph of the stove is presented in Figure 2.5. The stove's components are illustrated in the following sections.





Figure 2.5: Fully assembled domestic gasifier stove

An exploded view of the gasifier-gas burner component of the stove is shown in Figure 2.6.

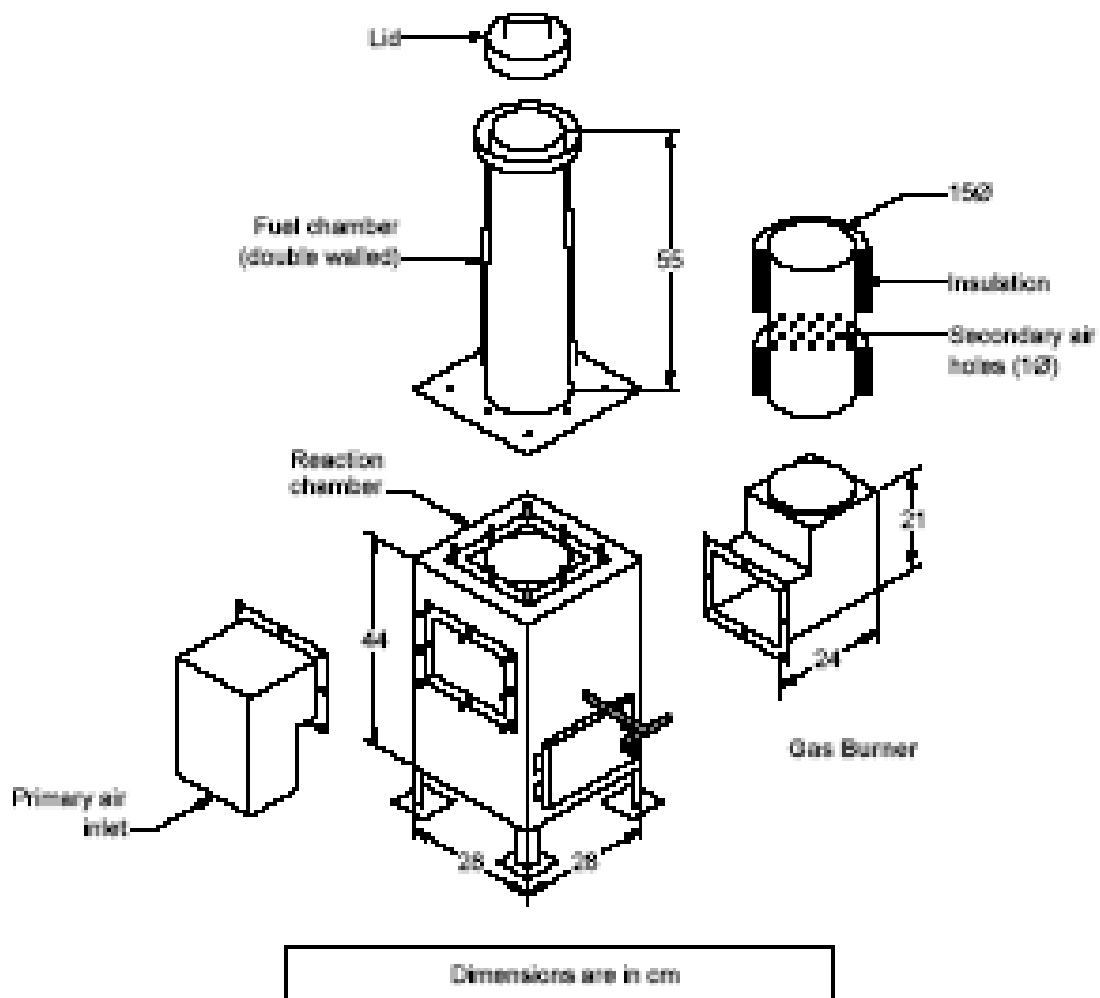

Figure 2.6: Exploded view of the gasifier stove.



Asbestos gaskets are used while connecting the different parts together. To prevent rusting, before and after assembling, the metal parts are painted with a high temperature spray paint (e.g.: No. 1200 HI-TEMP 1200°F Flat Black Spray Paint, of Bosny brand) available in hardware stores. *Reaction chamber*: The reaction chamber (Figures 2.7 and 2.8) is the key component of the stove where producer gas is generated. The outside wall of the chamber is made of 2 mm thick mild steel sheet, and fabricated over an L-angle frame of outside dimensions 28cm x 28cm x 44cm. The inside wall is made of a slotted mild steel cylinder; a layer of bricks, cemented together by Castable-13 refractory cement is placed between the two walls for thermal insulation.

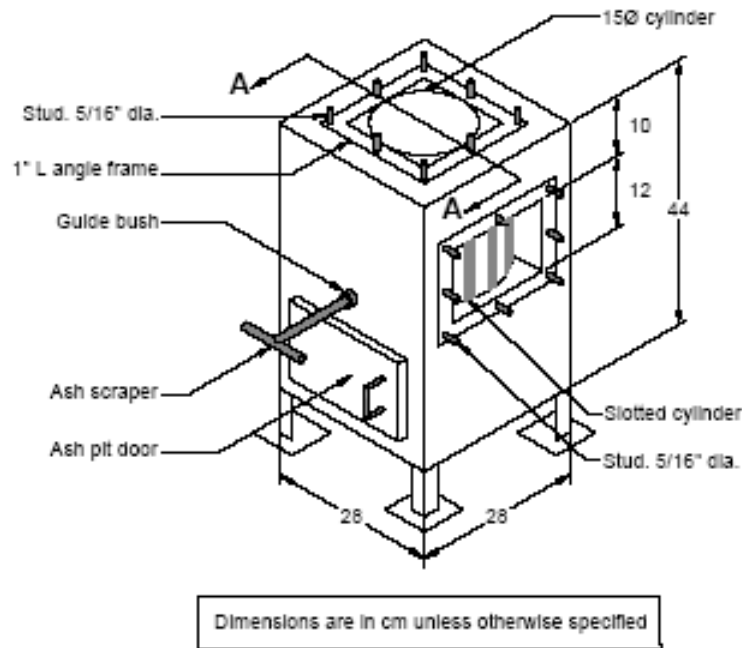

Figure 2.7: Isometric view of the reaction chamber

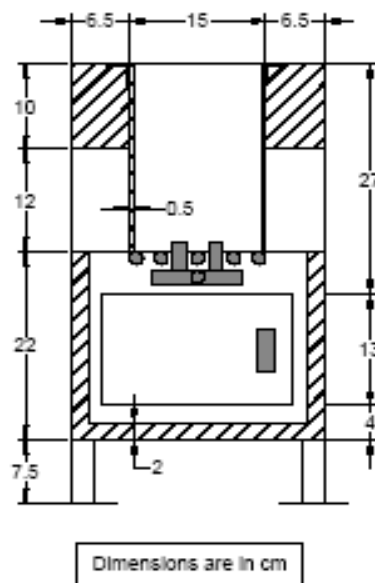

Figure 2.8: Cross-sectional view of reaction chamber

The slotted cylinder, forming the inner wall of the reaction chamber, is of 5 mm thick mild steel sheet, with an open top and a grate welded to its base. The cylinder has slots for air inlet and gas outlet, through which primary air enters into the reaction chamber at one side, and the producer gas exits the reaction chamber at the other side. The slots, six at each side, are provided as illustrated in Figure 2.9.

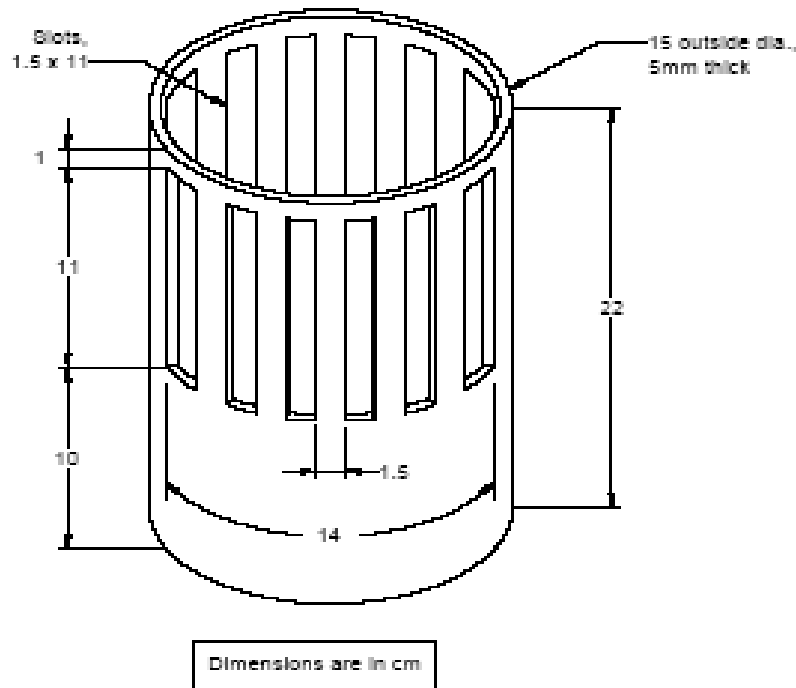

Figure 2.9: Slotted cylinder (shown upside down)

A mild steel grate is welded to the base of the cylinder. The grate (Figure 2.10) is made of round mild steel rods of 12.5 mm diameter, and allows ash to fall through it into the ash pit. An ash scraper (Figure 2.11) is fixed below the grate, to remove ash accumulated inside the reaction chamber. The ash scraper is especially useful while using fuels of high ash content, such as ricehusk briquettes, since accumulated ash could otherwise block the flow of fresh fuel from the fuel chamber into the reaction chamber.

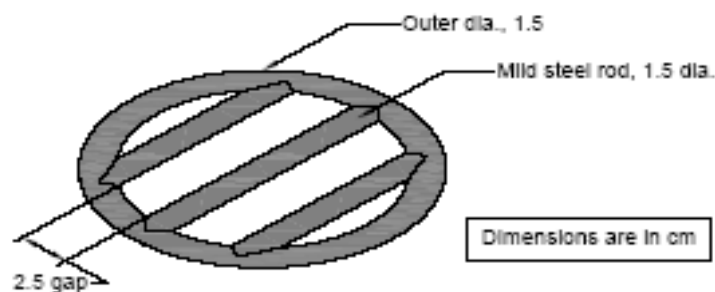

Figure 2.10: Grate (welded at the base of the perforated cylinder)

The ash scraper slides through a cylindrical guide bush, which is welded to the body of the reaction chamber. For easy assembling, the slider rod is connected to the 'fingers' of the scraper by a threaded joint. The ash scraper is operated by sliding it in and out horizontally, generally once in 10-20 minutes, depending on the ash content of the fuel.

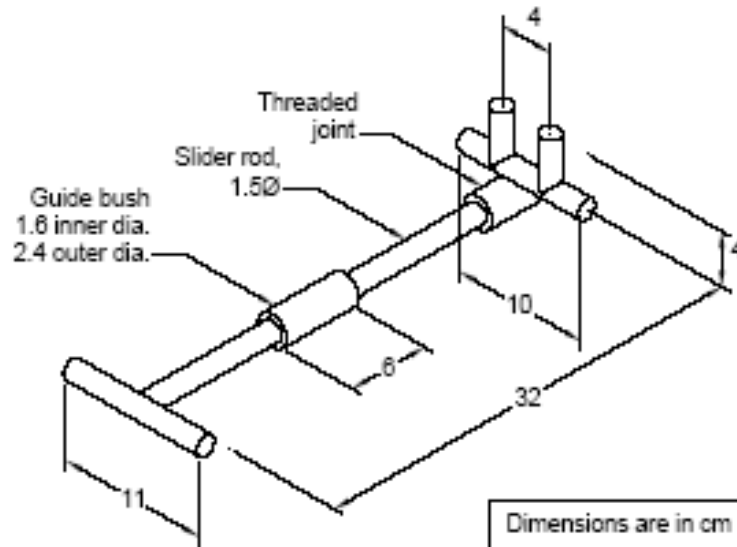

Figure 2.11: Ash scraper (with support bush)

A door is provided below the grate level in the reaction chamber, to access the ash pit. The door, made of 2 mm thick mild steel sheet, is fixed to the reaction chamber body using two hinges. A handle is welded to the door for easy opening and closing. The door is insulated with a refractory cement (Castable 13) layer of 1.5 cm thickness (Figure 2.12).

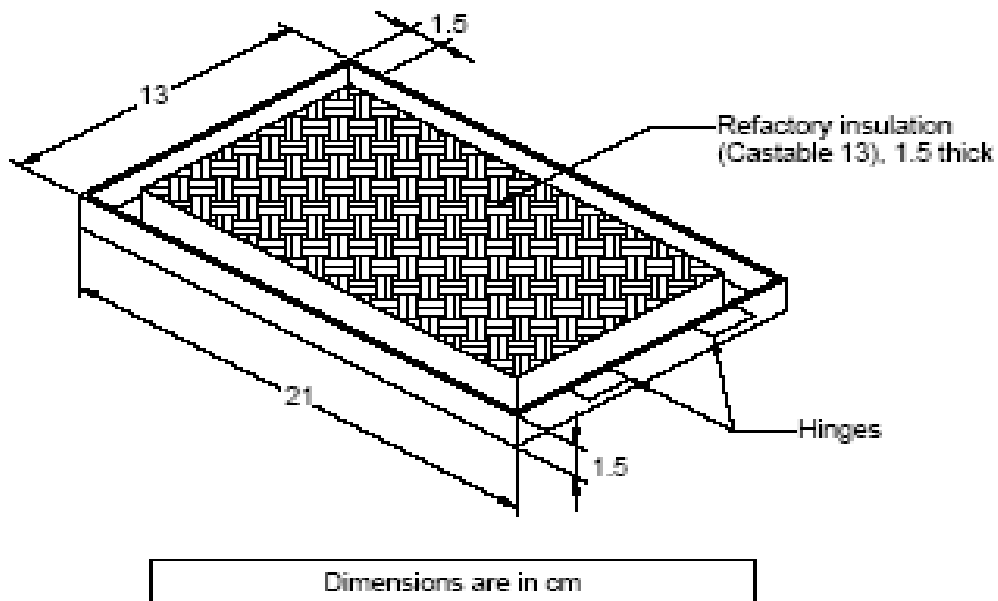

Figure 2.12: Ash pit door (Inside view)

The ash accumulated in the ash pit is periodically removed by opening this door. The door is also used while igniting the stove, by introducing a flame torch from below the grate, which supports the fuel bed inside the reaction chamber. *Fuel chamber*: The fuel chamber (Figure 2.13) is made of 2 mm thick mild steel sheet and is located above the reaction chamber. Fuel from the fuel chamber flows into the reaction chamber by gravity. The chamber is designed to be conical in shape, to avoid 'fuel bridging' inside the chamber, and to facilitate easy flow of fuel. The top end of the chamber has a water seal and a cup-type lid for easy loading of fuel; the water seal also prevents gas leakage from the joint during operation.

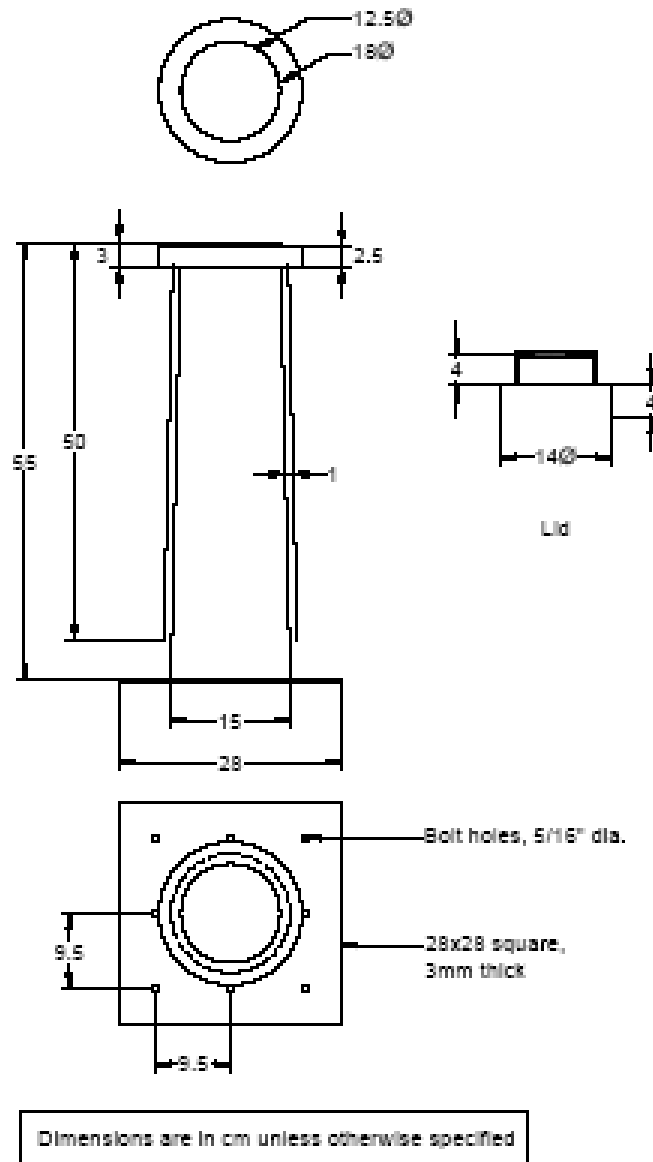

Figure 2.13: Fuel chamber

To protect the stove operator from accidental burns, and to reduce the heat losses further, the outside of the fuel chamber is covered with a mild steel shell, which is welded at the top with the water seal. The fuel chamber has a

flange attached at its bottom; this is used for connecting the fuel chamber with the reaction chamber. *Primary air inlet:* The primary air inlet (Figure 2.14) is made of 2 mm thick mild steel sheet, and is attached on one side of the reaction chamber. It is provided with a butterfly valve, which can be used to control the gasification rate inside the reaction chamber by controlling the primary air flow.

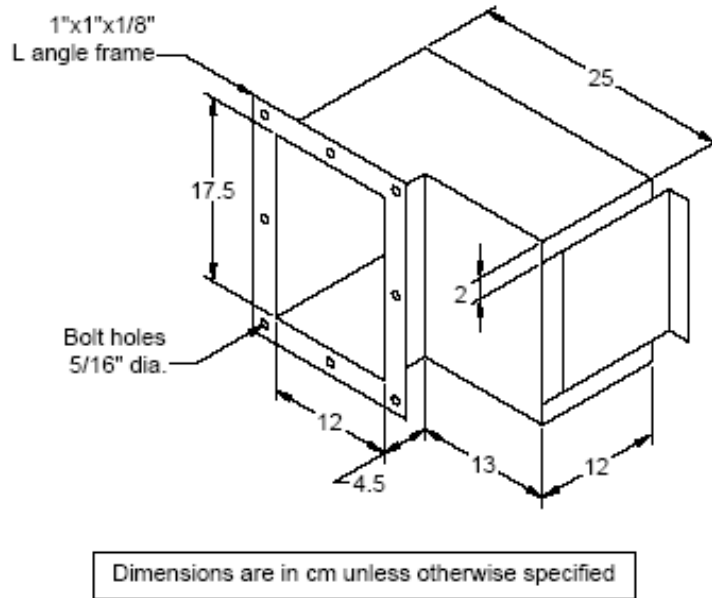

Figure 2.14: Isometric view of primary air inlet manifold

*Gas Burner:* The gas burner has two parts: the support at the bottom or gas burner base (Figure 2.15) and the burner pipe (Figure 2.16) which is fitted over the base.

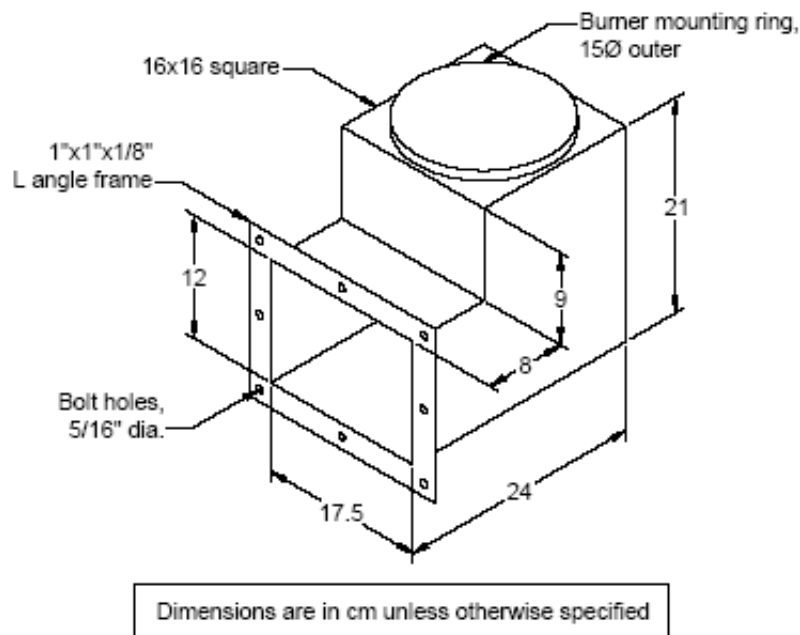

Figure 2.15: Isometric view of gas burner base

The burner pipe has forty-four holes of diameter 10 mm drilled into it in four rows, through which secondary air flows in, for combustion of the producer gas. To reduce heat losses, the surfaces above and below the secondary air holes are insulated with rockwool and clad with 1 mm thick GI sheet.

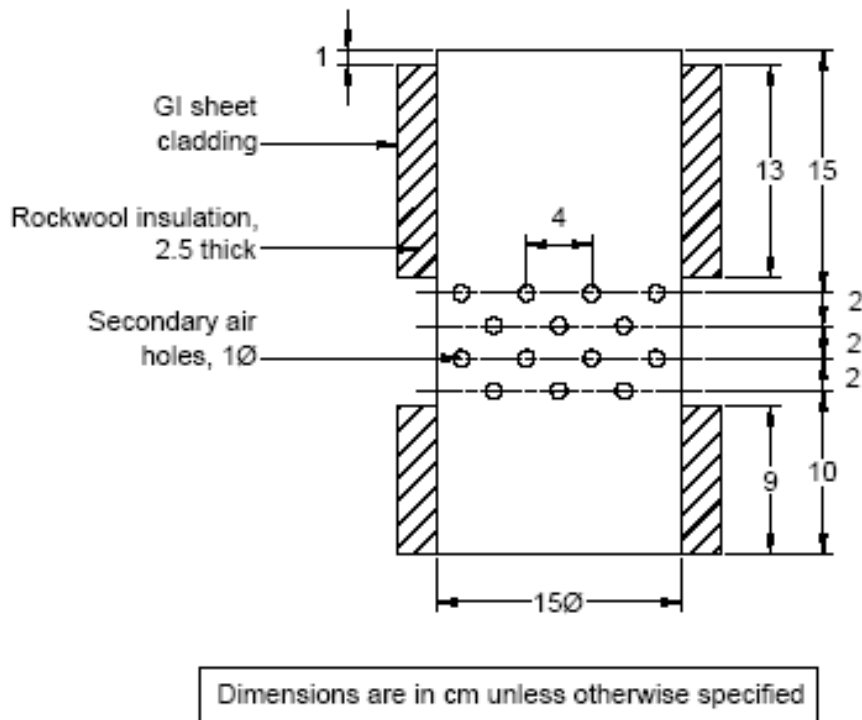

Figure 2.16: Sectional view of the gas burner

The gas burner base is insulated with a 2 cm layer of refractory cement (Castable 13) on its entire inner surface. The insulation reduces heat loss from the gases as they exit the reaction chamber before their combustion in the gas burner. Asbestos gaskets are used in the assembly of the individual components together. Three gaskets, of size 28cm x 28cm, 17.5cm x 12cm and 17cm x 20cm (outer dimensions), are used for connecting the fuel chamber, primary air inlet and the gas burner respectively, to the reaction chamber.

**Fuel Characteristics:** The gasifier stove is reasonably versatile in terms of the types of fuels it can handle. Ricehusk briquettes, wood chips and coconut shells were tested and found to be suitable for use in the gasifier stove.



Figure 2.17: Fuels used in the gasifier stove

Other fuels such as saw dust briquettes and wood twigs can also be used in the stove. The fuel should be sized before loading into the fuel chamber.

Figure 2.17

illustrates the types of fuels used in the stove. One inch is the average size of fuel pieces that can be used. *Stove ignition:* Fuel is first loaded in the fuel hopper, the lid is closed and the water seal is filled with water. The fuel is then ignited from below the grate using a flame torch through the ash pit door. About five minutes later, the torch is removed and the ash pit door is closed. The ignition builds up slowly, taking about 20 minutes for the combustible gases (producer gas) to generate at the gas burner side. The gases are then ignited in the gas burner by introducing a flame through the secondary air holes in the burner. Once the gas is ignited, the flow of gas becomes smooth. The stove can operate continuously for several hours, until the fuel in the fuel chamber is used up.

Additional fuel can be loaded through the top of the fuel chamber to extend operation.

### ***Flat Plate Solar Collector***

The dimensions of the flat plate solar air heater are 2m x 2m. The cover glazing is 4 mm thick tempered glass. Glass wool insulation is provided below the absorber sheet. The absorber and insulation materials are placed inside a mild steel box, which protects the interior from moisture/rain. The air inlet to the collector is fitted with a fine stainless steel wire mesh. The solar collector is placed facing south at an angle of 15° to the horizontal for absorbing maximum solar radiation during summer.

### ***Heat Exchanger***

A heat exchanger transfers heat from the flue gas from the gasifier stove to the drying air entering from the solar collector and bottom air blowers/openings of the drying chamber. The heat exchanger, fitted above the level of the solar collector air outlet, is of cross-flow type with hot flue gas flowing through horizontal pipes and process air flowing up across these pipes. The central pipe of the heat exchanger (6" diameter) and two side pipes (4" diameter) are fabricated from mild steel sheet. The center pipe and side pipes are connected with eighteen 2" diameter steel pipes.

### ***Temperature Controller***

A temperature controller using a thermostat is provided to maintain the temperature of hot air within specified limits. The thermostat controls the primary air supply to the biomass stove. A car radiator thermostat with a working temperature of 76.5°C is used as a temperature controller in the drying system. The thermostat is fixed inside a housing which has eight copper fins, each of size 7cm x 3cm welded to an annular cylinder. This housing has been provided to enhance the heat transfer from the hot air to the sensing element in the thermostat. The thermostat is fixed on the central heat exchanger pipe near the entrance of flue gas from the gasifier stove. The temperature of drying air inside of the dryer can be set to a particular value by adjusting the height of the thermostat expander rod above the heat exchanger pipe. When the average temperature inside the dryer rises above the desired level, the thermostatic element will extend and push the short arm of a lever;

the long arm of the lever pulls a vertical rod to close the butterfly valve at the stove's inlet so that flow of primary air to the gasifier stove will be reduced. When the airflow to the reaction chamber is reduced, the amount of producer gas generated for combustion is also reduced, so that the temperature in the drying chamber drops. When the temperature drops to a set level, the thermostat will move back to the normal position and the butterfly valve will be opened. The mechanism of the control system of the thermostat is illustrated in Figure 2.18. A photograph of the thermostat, fixed inside the drying chamber, is presented in Figure 2.19.

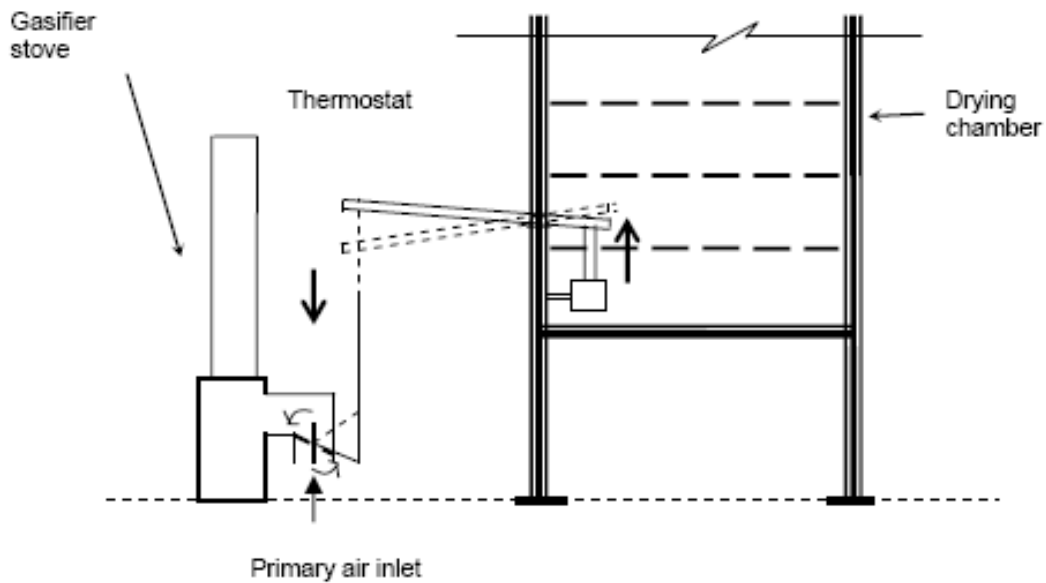

*Figure 2.18: Thermostat working principle*

Using the temperature controller, the inside temperature of air inside the drying chamber can be maintained in the range of 55-65°C.





*Figure 2.19: Thermostat used in the temperature control mechanism*

The completed hybrid solar-biomass cabinet dryer is presented in Figure 2.20. The dryer has been tested with products such as banana, mushroom, chilly and radish, and the performance is found to be good.



*Figure 2.20: The solar-biomass hybrid cabinet dryer*

### **Operation and Maintenance Requirements**

The main advantage of using the gasifier stove is that the dryer can be operated continuously for several hours with a steady heat input, with minimum attention. This dryer is constructed of bricks and mortar, and is more efficient than a conventional solar cabinet dryer made of steel or aluminum. The hot flue gases from the biomass gasifier stove are used to heat the process air inside the drying chamber, using a pipe heat exchanger and an

automatic temperature control mechanism that allows the temperature of air inside the drying cabinet to be maintained in the range 55-65°C.

### **Specific Considerations for Developing Countries**

Biomass is locally available in rural areas of developing countries and is often the cheapest source of energy. In addition, biomass fuels can provide an uninterrupted supply of thermal energy needed for continuous operation of dryers. Hybrid drying powered by biomass and solar energy is a potentially important option for small-scale operations since it combines the advantages of drying systems operated by solar energy alone and those operated by biomass alone. During sunny weather, the dryer is operated in the solar mode which reduces the need for biomass fuels and associated costs. Use of biomass fuels, however, enables a continuous day and night operation even during cloudy or rainy weather.

### **Examples of Real Life Applications**

Asian Institute of Technology (AIT), Thailand

### **Suppliers**

Asian Institute of Technology (AIT), Thailand<sup>40</sup>

P.O. Box 4, Klong Luang, Pathumthani 12120, Thailand

Telephone: (66 2) 5160144 or (66 2) 5245000 Fax: (66 2) 516 2126

---

<sup>40</sup> [http://www.ait.ac.th/interimage/ait\\_visitor/index.asp?screen=&res=800x600](http://www.ait.ac.th/interimage/ait_visitor/index.asp?screen=&res=800x600)

**Greenfire™<sup>41</sup>**  
**USA, Commercial**

<b>Crop</b>	Wood, corn, wheat
<b>Residue</b>	Wood pellets, shelled corn and hulled wheat
<b>Process</b>	Combustion
<b>Equipment</b>	Stove
<b>Main Product</b>	Heat

**Technical Description of Technology**

Type	Estimated annual cost
Electric	\$1,505
Propane	\$1,390
Oil furnace	\$1,005
Natural Gas	\$884
Pellet	\$658
Corn	\$385



<sup>41</sup> [http://greenfire.pelletstove.com/europa\\_productinfo.php](http://greenfire.pelletstove.com/europa_productinfo.php)

The Europa 75 is a multi-fuel stove with Greenfire™ technology inside. The first stove of its kind, the Europa 75 burns natural bioenergy materials like wood pellets, shelled corn and hulled wheat with an amazing 86% efficiency.

In addition to heating efficiently, the Europa 75 burns cleanly. It is certified by the US environmental Protection Agency (EPA) and received the lowest emissions rating of any certified non-catalytic product in EPA history, less than 0.6 grams per hour - 12.5 times below the allowable limit.

Electricity, gas, oil and propane are non-renewable resources that will continue to increase in cost as global demand for fuel increases. Heating with the Europa multi-fuel stove, renewable bioenergy materials like wood, corn and wheat are burned, these fuels are affordable and readily available in North America. In addition, these bioenergy fuels do not contribute to climate change.

### **Examples of Real Life Applications**

Commercial level at homes across Europe and America

### **Suppliers**

Dell-Point Technologies, Inc.

Mark Drisdelle

[drisdelle@pelletstove.com](mailto:drisdelle@pelletstove.com)

## Mayon Turbo Stove and Lo Trau Stove<sup>42</sup> Philippines, Commercial

<b>Crop</b>	Rice, peanut, coffee, corn, coconut, wood
<b>Residue</b>	Peanut shells, coffee shells, corn cobs, crushed coconut shells, and sawdust (mix at a level of 1/3-1/2 rice hull)
<b>Process</b>	Combustion
<b>Equipment</b>	Mayon Turbo Stove and Lo Trau Stove
<b>Main Product</b>	Heat for cooking

### Technical Description of Technology

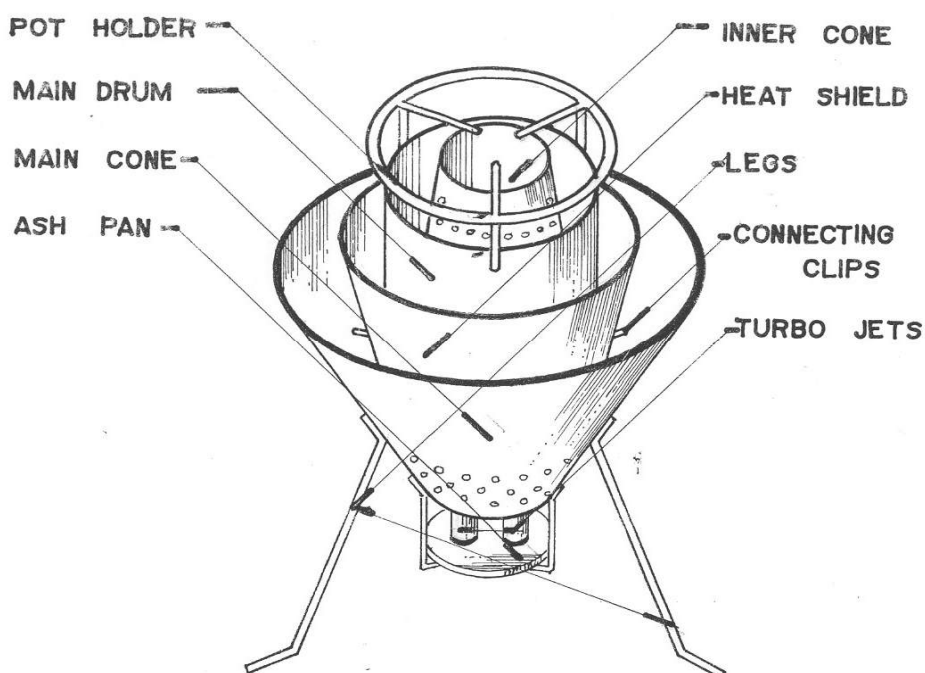

### Detailed Process Description<sup>43</sup>

After a 3-5 minute start-up period, a blue or non-luminous flame was present throughout the inner cone of the MTS. Maintenance of the stove is also reduced, with tapping required only after approximately 7-10 minutes from start-up to introduce additional fuel. The stove is now thought to possess a near optimal air flow; there appears to be no excess air and no oxygen deficient areas of the cone or oxygen deficient periods during the entire burn cycle. Following start-up, smoke only begins to appear again when additional

<sup>42</sup> Sustainable Household Cooking in the Philippines , The Development of the Mayon Turbo Stove by: Roger Samson and Claudia Ho Lem, REAP-CANADA

<sup>43</sup> [http://www.reap-canada.com/bio\\_and\\_climate\\_3\\_3\\_2.htm](http://www.reap-canada.com/bio_and_climate_3_3_2.htm)

fuel is required to maintain combustion. There is no smoke events related to lack of air when adequate fuel is present. The burnt ash is now a whitish-grey colour, indicating more complete biofuel combustion.

### Job Potential<sup>44</sup>

The stove reduces the laborious task for women of fuelwood gathering, which typically requires 60-120 days per year of work in upland communities in Negros Occidental. The economic savings increased when the analysis projected the costs of stove users who were entirely purchasing their fuel supplies. Rice hull stove users were estimated to have annual cooking costs of only \$4.87 USD per year compared to \$61.98, \$67.54 and \$77.32 for cooking with purchased firewood, charcoal, and LPG respectively. The projected savings from 100% displacement of rice hulls for other purchased fuels represented 7.6-9.6% of the total annual family income.

### Parameters for Procurement Specifications<sup>45</sup>

The stoves were made at a local small tool fabrication workshop operated by PDG and MAPISAN in Negros, as well as farmers association in Panay. The stoves were sold and distributed in Negros mainly by PDG and affiliated farmer's federations belonging to the MAPISAN Farmer's Alliance.

### Operation and Maintenance Requirements<sup>46</sup>

A smaller model of stove the MTS 6500 (having a 6.5 inch diameter fuelbed) has also been developed. The original MTS-7000 model (having a 7-inch diameter fuelbed) appears best suited to larger households (10 or more members) or small commercial applications. There has been favorable feedback from Philippine communities using the new MTS models with some reporting 100% substitution of conventional fuels. The new MTS 6500 stove can allow a family of 6 to cook with approximately one tonne of rice hull per year. With a simple level of training, families are now enjoying a high quality non-luminescent flame cooker that is becoming locally known as the poor man 's gas stove.

### Greenhouse Gas Emission Reductions<sup>47</sup>

Fuel	Greenhouse Gas Emission Reductions (kg CO <sub>2</sub> equiv)					GWC*
	CO <sub>2</sub>	CH <sub>4</sub>	N <sub>2</sub> O	CO	TNMOC	
Fuelwood	0	243.75	150.17	216.39	152.78	0.44
Charcoal	0	43.36	10.54	53.48	68.65	3.26
LPG	22.21	0.01	0.73	0.22	1.35	3.41
Kerosene	16.69	0.04	0.30	0.19	0.82	2.64
<i>Direct GHG = 487.8</i>				<i>Indirect GHG = 493.9</i>		
<b>Total GHG Emissions = 981.7 kg CO<sub>2</sub> Equiv per year</b>						

<sup>44</sup> [http://www.reap-canada.com/bio\\_and\\_climate\\_3\\_3\\_4.htm](http://www.reap-canada.com/bio_and_climate_3_3_4.htm)

<sup>45</sup> [http://www.reapcanada.com/online\\_library/Reports%20and%20Newsletters/International%20Development/8%20Philippines%20Agricultural.pdf](http://www.reapcanada.com/online_library/Reports%20and%20Newsletters/International%20Development/8%20Philippines%20Agricultural.pdf)

<sup>46</sup> [http://www.reap-canada.com/bio\\_and\\_climate\\_3\\_3\\_2.htm](http://www.reap-canada.com/bio_and_climate_3_3_2.htm)

<sup>47</sup> Sustainable Household Cooking in the Philippines , The Development of the Mayon Turbo Stove by: Roger Samson and Claudia Ho Lem, REAP-CANADA

### **Social Considerations**

The stove was found to largely displace gathered and purchased fuelwood, as well as some charcoal and LPG use. On average, the introduction of a \$7 USD (although the stove is currently being produced at \$10 USD) rice hull stove reduced the annual fuel expenditures for cooking (fuel and firestarter costs) from \$35.58 to \$13.17 (De Maio et al., 2002).

### **Investment and Operating Cost**

For \$10 USD per cooker, impoverished families are gaining access to this new stove to reduce their household cooking expenses and to improve indoor air quality.

### **GHG Emission Reduction Potential**

Same table as Environmental Considerations

### **Advantages to Developing Countries**

- **High efficiency and clean combustion:** high quality, swirling blue flames are created from the twin primary air injectors and the extended inner cone with secondary air holes
- **Economical:** Average annual cooking costs and stove purchase is approximately \$10 USD for the MTS, compared to \$60-100 USD for cooking with purchased firewood, charcoal and LPG
- **Fast boiling:** 1 litre of water can boil in 6-7 minutes
- **Convenient to use:** tapping to introduce new fuel is required approximately only every 7-10 minutes
- **Low fuel consumption:** Approximately 2.5 sacks (25 kg) of rice hull/family/week
- **Portable and lightweight:** steel construction, weighing approximately 4 kg; can be used both indoors and outdoors
- **Uses a variety of biofuels:** Enables the use of many fuels to be used in conjunction with rice hull including corn cobs, peanut shells, cocoa shells, crushed coconut shells, millet husk, and sawdust
- **Safety:** a ring structured holder provides excellent pot stability
- **Holistic Use of Fuel:** ashes can be reused as a soil conditioner, fertilizer, and pest repellent around plants.

### **Example of Real Life Applications<sup>48</sup>**

Commercial Level REAP-Canada -Mayon Turbo Stove and Lo Trau Stove  
Panay and  
Negros Occidental

### **Supplier**

PDG and MAPISAN Farmer's Alliance in Negros Occidental (REAP-Canada and CIDA)

---

<sup>48</sup> [http://www.reap-canada.com/bio\\_and\\_climate\\_3\\_3\\_4.htm](http://www.reap-canada.com/bio_and_climate_3_3_4.htm)







## Commercial Gasifier<sup>49</sup> Philippines, Commercial

<b>Crop</b>	Wood, cotton, rice
<b>Residue</b>	Wood chips, cotton stalks, briquettes, rice hull
<b>Process</b>	Gasification
<b>Equipment</b>	Gasifier
<b>Main Product</b>	Producer Gas

### Technical Description of Technology

A gasifier is a device that converts various biomass materials such as wood chips, cotton stalks, briquettes, rice hull etc. into a combustible gas called producer gas. This gas is a mixture of hydrogen, carbon monoxide, methane and traces of other hydrocarbon, which is formed under incomplete combustion at high temperatures. Gasifiers are however, not so popular because of uncertainty in biomass fuels and also because the integration of gasifier into an existing process is often not straight forward, and it involves some developmental work which most are not willing spend for.



### Examples of Real Life Applications Philippines

---

<sup>49</sup> <http://www.teriin.org/news/terivsn/issue30/biomass.htm>

**Modul-Pak<sup>50</sup>**  
**USA, Commercial**

<b>Crop</b>	Sugarcane, coconut, coffee, corn, peanut, rice
<b>Residue</b>	Bagasse, coconut hulls, coffee grounds, corn cobs, peanut hulls, rice husks, switchgrass
<b>Process</b>	Combustion
<b>Equipment</b>	Modul-Pak <sup>®</sup> Boiler
<b>Main Product</b>	Steam

**Production Capacity**

<b>Modul-Pak<sup>®</sup> Design Parameters</b>	
•Steam capacities	10,000 LB/hr to 55, 000 lb/hr (4.5 t/hr to 25 t/hr)
•Maximum design pressure	325 psig (22.5 bar)
•Maximum steam temperature	Saturated
•Furnace construction	Refractory & membrane wall

**Detailed Process Description**

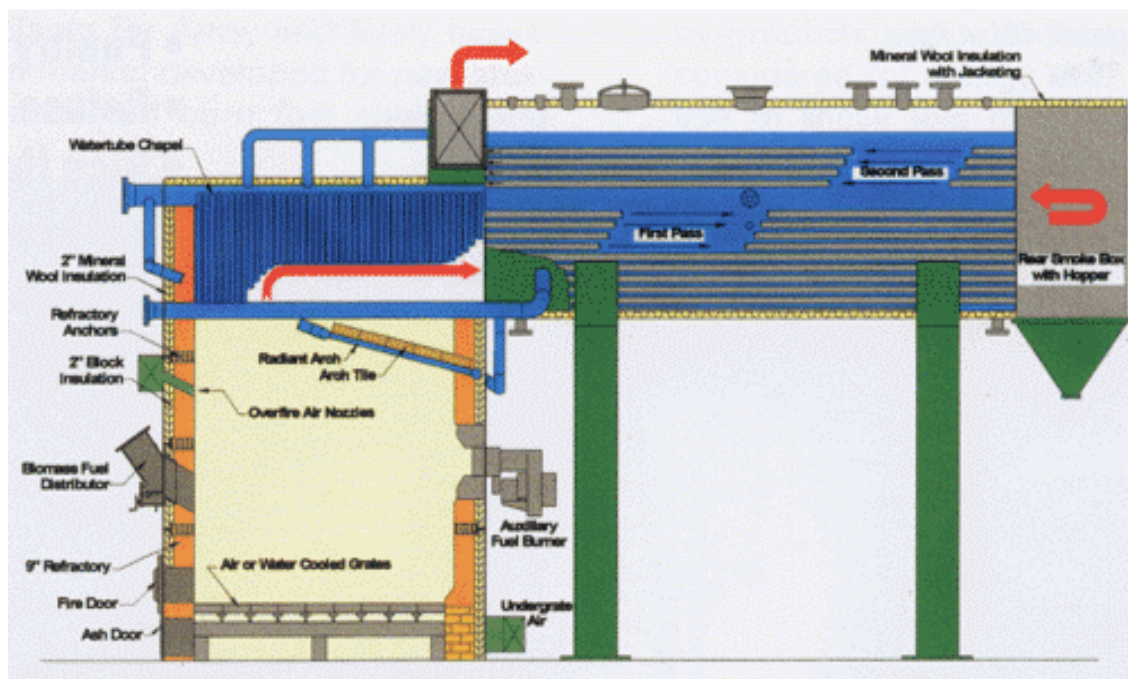

<sup>50</sup> <http://www.mcburney.com/biomass.htm#mod>



The Modul-Pak<sup>®</sup> boiler is a hybrid design that combines the benefits of a watertube furnace and a multipass firetube boiler. The results are a value engineered modular package boiler that offers unique advantages for solid fuel firing.

#### **Institutional and Regulatory Consideration or Requirements**

- Performed in strict accordance with the applicable ASME Boiler and Pressure Vessel Codes, the National Board Inspection Code, and any jurisdictional requirements that may apply. McBurney currently holds the following ASME and National Board Certificates of Authorization:
  - A** for the assembly of power boilers which are designed and manufactured by others.
  - PP** for the design, alteration, manufacture, and erection of power piping.
  - R** for in-kind repair of boilers and pressure vessels.
  - S** for the design, alteration, manufacture, and erection of power boilers.

#### **Examples of Real Life Applications**

Commercial use                      Modul Pak1650                      International Court  
    Suite 100 Norcross,  
    GA 30093

**Supplier**  
 Mcburney

## PyStR™ (Pyrolysis Steam Reforming)<sup>51</sup> USA, Commercial

<b>Crop</b>	Mixed
<b>Residue</b>	A range of carbon-bearing feedstock (biomass, tire waste, petroleum coke, etc.)
<b>Process</b>	Pyrolysis
<b>Equipment</b>	PyStR
<b>Main Product</b>	Purified hydrogen

### Technical Description of Technology

The PyStR process converts synthesis gas produced by the gasification unit using a range of carbon-bearing feedstocks (biomass, tire waste, petroleum coke and so on) into hydrogen or methane by reacting the CO- and hydrogen-rich syngas with steam and calcium oxide (lime).

The reaction creates  $\text{CaO}_3$  as a byproduct, which is then transformed back into calcium oxide and carbon dioxide. The  $\text{CO}_2$  is partially reintroduced into the hydrogen production process, or can be captured and used or sequestered.

During PyStR “Proof of Concept” testing, 96%  $\text{H}_2$  purity was achieved. This will greatly reduce the cost of hydrogen purification in contrast to existing conventional commercial systems. For this reason we believe PyStR will reduce hydrogen cost significantly below the DOE (Department of Energy) goal.

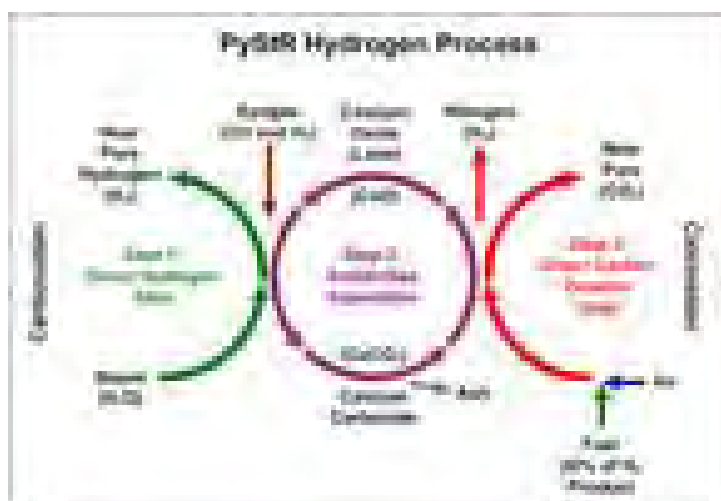

### Example of Real Life Applications

Energyquest anticipates commercialization of PyStR in fiscal 2007.

<sup>51</sup> [http://www.greencarcongress.com/2006/05/gasification\\_co.html](http://www.greencarcongress.com/2006/05/gasification_co.html)

## Suppliers

Energy Quest, Inc.  
850 South Boulder Hwy, Suite 169  
Henderson, Nevada, USA  
89015 – 4131

Sales and Marketing : [info@nrggst.com](mailto:info@nrggst.com)

Telephone: 1.702.568.4131

Toll Free: 1.877.568.4137

Fax: 1.702.366.0002



## **Rapid Thermal Processing (RTP™)<sup>52</sup> USA, Commercial**

<b>Crop</b>	Biomass
<b>Residue</b>	Carbon-based materials, including either wood (biomass) or petroleum hydrocarbons
<b>Process</b>	Thermal Conversion
<b>Equipment</b>	RTP system
<b>Main Product</b>	Bio oil
<b>By-Product</b>	Chemical and fuel products

### **Technical Description of Technology**

Ensyn's patented core technology, Rapid Thermal Processing or RTP™, is an extremely fast thermal conversion process characterized by moderate temperatures and atmospheric pressure. In the RTP™ system, carbon-based materials, including either wood (biomass) or petroleum hydrocarbons, are quickly transformed to more valuable chemical and fuel products by the rapid addition of heat. The process is simple, achieves high capacities utilizing a compact design and has a relatively low capital cost.

Ensyn's current bio-oil production capacity is 5 million gallons annually. The bio-oil is further processed to produce final chemical, fuel and carbon products that consistently meet stringent customer specifications.

When biomass and petroleum are processed using a combination of rapid heat addition and very short processing times (typically less than a few seconds), high yields of value-added products are obtained. In commercial RTP™ operations, processing times are usually less than one second and product yields are significantly higher than with any other available industrial technology.

Ensyn believes that RTP™ is the only bio-oil technology in the world that is operating commercially, and that RTP™ is the only technology capable of producing large quantities of bio-fuel from industrial operations.

In support of the core RTP™ process, Ensyn owns a significant array of additional intellectual property (I.P.). Such I.P. covers unique RTP™ products,

---

<sup>52</sup> <http://www.ensyn.com/what/rtp.htm>

as well as the extraction, recovery and use of certain chemicals and upgraded RTP™ products.

### **Specific Considerations for Developing Countries**

RTP™ is:

- Proven;
- Adaptable;
- Scalable and cost-effective

### **Examples of Real Life Applications**

The 70 ton per day RTP™ facility in Wisconsin is owned by Red Arrow Products Company, Inc. and operated by Ensyn. This facility produces a number of food, natural chemical, and liquid "bio-fuel" products and operates with an availability exceeding 95%.

### **Supplier**

Ensyn Corporation  
Head Office, 400 W 9th Street  
Willmington , Delaware  
Telephone: +1 302 425-3740  
Fax: +1 302 425-3742

Ensyn Corp Subsidiaries:

Ensyn Technologies Inc.  
Corporate Offices and Engineering  
2 Gurdwara Road, Suite 210  
Ottawa, Ontario, Canada K2E 1A2  
Telephone: +1 613 248-2257  
Fax: +1 613 248-2260

Ensyn Renewables Inc.  
400 W 9th Street, Willmington, Delaware  
Telephone: +1 302 425-3740  
Fax: +1 302 425-3742

Ensyn International Ltd.  
Broughton House, 6-8 Sackville Street  
London W1X 1DD, United Kingdom  
Telephone: +1 44 20 7434-1821  
Fax: +1 44 20 7434-1908

## 30 MW Cogeneration System<sup>53</sup> Spain, Commercial

<b>Crop</b>	Olives
<b>Residue</b>	Waste products from the olive oil production process
<b>Process</b>	Incineration
<b>Equipment</b>	Gas turbine and steam turbine generator
<b>Products</b>	Electricity

### Technical Description of Technology

**Table 1. Main plant data**

Electrical power (kWe)	Minimum	Nominal	Maximum
Steam turbine power	14,015	14,711	15,600
Gas turbine power	13,112	13,112	13,112
Internal consumption	1434	1530	1620
Total exported (after transformer losses)	25,483	26,076	26,862
Fuel: biomass (orujillo)		Fuel: liquid natural gas (LNG)	
Total combustion heat	47,000 kW	Storage capacity	700 m <sup>3</sup>
Consumption	9872 kg/hour	Consumption	3480 Nm <sup>3</sup> /hour
Specific consumption	3.28 kW/kWe	Specific consumption	2.88 kW/kWe
Amount burnt	77,000 tonnes/year	–	–
Humidity after drying	12%	–	–
LHV	4000 kcal/kg	–	–

### Detailed Process Description

#### Phase I: Production of pomace oil

The alperujo from various olive oil mills within a 70 km radius of Lucena (which includes the provinces of the Community of Andalusia, such as Córdoba, Jaén, Málaga, Seville and Granada) is stored in two new evaporation ponds with a total capacity of 170,000 tonnes.

The pond-filling process is known as *campana* (referring to the annual harvest) and lasts approximately five months, which is the length of the olive

<sup>53</sup> [http://www.cospp.com/display\\_article/296041/122/CRTIS/none/none/A-cultivated-choice---30-MW-biomass-project-in-C%C3%B3rdoba,-Spain](http://www.cospp.com/display_article/296041/122/CRTIS/none/none/A-cultivated-choice---30-MW-biomass-project-in-C%C3%B3rdoba,-Spain)



oil production period in the mills. The stored product is processed in some six months.

The alperujo is then put through a physical process using decanters, or horizontal centrifuges, to extract pomace oil and further alperujo. An annual production of some 2000 tonnes of pomace oil is expected, which will be sent to the refineries before being used for human consumption.

The alperujo has good heating value but also contains a high level of moisture, rendering it unviable for combustion. Therefore this residue must be dried before being used as fuel.

## **Phase II: drying the alperujo**

About 240,000 tonnes/year of olive oil residue (orujo) is available. This residue has a moisture level of 65% - 70% and must be dried before it can be recycled. The drying system consists of a horizontal drier (trommel-type) which uses hot gases from a combustion chamber for drying.

In the past, the dried pulp residue (orujillo), normally with the stones removed, was combusted in a chamber to generate hot gases of 500°C. The drying process consisted of two phases. In the first phase, approximately 48% of the moisture was driven out. Then the material went into a second dryer where its moisture was reduced to 10% - 12%. Some of the dried orujillo obtained was used as fuel for the drying process itself and the remainder sold to industrial facilities such as brick factories. However, the introduction of natural gas in Spain has considerably decreased the demand for orujillo.

In view of the special characteristics of the dryer, the heat required appeared very well in line to the latent heat in a gas turbine generator package, which produces gases at a temperature of around 500°C. This led to the development of a drying phase along with the use of the TBM-T-130 gas turbine generator, which is able to supply heat for the dryers while producing electrical energy. The special combustion characteristics of the gas turbine generator package ensure that the exhaust gases are clean, without any traces of lubrication oil or pollutants.

At the end of the process, two different products with a high specific value are obtained. Of these, orujillo with a moisture content of 10% - 12% is suitable for direct combustion. It is also recyclable,

either for sale to third parties or for use in the new cogeneration plant, which is connected to the Endesa grid. The dried orujillo, the other product, is stored in a silo in an area near the cogeneration plant.

## **Job Potential**

<sup>1</sup> The plant is being operated in three shifts with two operators and a supervisor. Furthermore there are two maintenance engineers and two plant managers. The project provides 19 jobs in total.

## **Parameters for Procurement Specifications**

<sup>1</sup> Turbomach earned the contract for the engineering, procurement and construction (EPC) of the biomass-fired power plant in Lucena, Córdoba. The plant is based on a 14.3 MWe gas turbine generator package, an olive oil residue incinerator and heat recovery system, and a 14.8 MWe steam turbine generator package. Turbomach has been acting as the main contractor and O&M contractor for the plant. The gas turbine and steam turbine generator packages are products from Turbomach.

## **Operation and Maintenance**

<sup>1</sup> As discussed, the heat requirement for the drying process, on the basis of operating more than 8200 hours/year, permitted the installation of a 14.3 MWe gas turbine generator package based on the Solar Titan 130 industrial gas turbine which generates more than 100,000 MWh/year. The exhaust gases are supplied directly and in parallel to two tram-mel-type dryers. Gases exit the gas turbine generator at 45 kg/s at about 495°C. About 10% of the exhaust gases from the gas turbine is conducted to the biomass boiler to increase the plant efficiency by pre-heating the boiler's combustion air, which will be regulated to minimize the formation of NOx and CO.

The fuel efficiency of the cogeneration plant is close to 90%, whereas the electrical efficiency is 34%. Approximately 1.5 MWe is used for the plant's own consumption. The gas turbine is fed with LNG stored at the site. In the future the plant will connect to the gas pipeline at the town of Lucena in Córdoba.

Out of the approximately 92,600 tonnes/year of orujillo with 10% - 12% moisture and around 4000 kcal/kg of heating value, around 77,000 tonnes are burnt per year in the biomass plant. The rest will be provided as fuel to the Hermanos Santamaría plant.

Orujillo is combusted in the biomass boiler that produces steam at highpressure and temperature. The biomass boiler will produce superheated steam at about 65 bars and 450°C, at about 55 tonnes/hour. The boiler has a high heat output so that the efficiency of the biomass plant surpasses 30%. The flue gas from the boiler is filtered to prevent the emission of particles into the atmosphere.

The steam produced is expanded up to 0.08 bar in a Turbomach-TV2 steam turbine generator package. The steam turbine is a MARC4C01 system manufactured by B+V Industrietechnik. It is equipped with an intermediate bleed to feed the thermal de-aerator. The steam turbine generator package has a capacity of about 14.8 MWe, with the export of some 104,000 MWh/year of electrical energy.

The electrical power generated by the plant at 11 kV will be connected to the Sevillana-Endesa grid at 66 kV via a step-up transformer station. The plant is furthermore provided with its own utilities for compressed air and low-voltage power (400 V). Both the gas turbine generator package and the steam turbine generator package are installed outdoor with their own individual

weatherproof and sound-attenuating enclosures. The electrical substations are also located outdoor. The plant is provided with one main building where the auxiliary services and control room is located.

In order to increase plant efficiency and taking into account the climate of the site (high temperature and low humidity in summer), an evaporative cooler system is installed in the gas turbine combustion air inlet system to reduce the temperature of the combustion air to a maximum of 20°C. This increases the power output of the gas turbine generator from 12,400 kW to 12,800 kW in periods of extreme heat. This cooler will be fed by osmotized water from the biomass plant. The steam will be condensed in a condenser, which will be cooled by water from cooling towers.

### **Requirements**

The facility has been designed to work non-stop and at 100% load for some 7800 hours per year. Virtually all of the olive oil plant's auxiliary services will be shared with the cogeneration plant.

Together with the turnkey supply agreement, Turbomach has signed a contract for the operation and maintenance of the cogeneration and biomass plant for a period of 20 years. The plant is being operated in three shifts with two operators and a supervisor. Furthermore there are two maintenance engineers and two plant managers. The project provides 19 jobs in total.

### **Environmental Considerations**

<sup>1</sup> The incineration of biomass can be considered CO<sub>2</sub>-neutral as the CO<sub>2</sub> captured during the growth of the olives (via photosynthesis) is being released again to the atmosphere. In comparison to a coal-fired power plant, biomass incineration at the plant reduces the emission of CO<sub>2</sub> by about 110,000 tonnes per year.

### **Social Considerations**

<sup>1</sup> The European regulations on the disposal of agricultural waste and the associated cost of this disposal can have a big impact on the economics of the olive oil production process - costs that are ultimately passed on to end-users. Therefore it is essential to find solutions for the utilization and valorization of the olive oil waste.

The use of biomass for drying, incineration and power generation is economically feasible and can be easily integrated into a factory's existing equipment. The technology has great economic and environmental benefits compared with open combustion of the waste. With the world producing about 2 million tonnes of olive oil per year (including 660,000 tonnes in Spain alone, 500,000 tonnes in Italy, and 360,000 tonnes in Greece), there is a large potential for this well proven technology.

### **GHG Emission Reduction Potential**

The incineration of biomass can be considered CO<sub>2</sub>-neutral as the CO<sub>2</sub> captured during the growth of the olives (via photosynthesis) is being released again to the atmosphere. In comparison to a coal-fired power plant, biomass

incineration at the plant reduces the emission of CO<sub>2</sub> by about 110,000 tonnes per year.

### **Examples of Real Life Applications**

Commercial Use Bioenergía Santamaría 30 MW biomass project  
Córdoba, Spain

### **Suppliers**

Turbomach SA is a well-established name in the world power market. The company is wholly owned by Caterpillar (USA). The company has accumulated more than 25 years of knowledge and experience in technical design, application engineering, and manufacturing of power plants based on its gas and steam turbine packages.



**Primenergy R-18 Gasifier producing Energy from Olive Waste  
U.S.A., Commercial**

<b>Crop</b>	Olive
<b>Residue</b>	Olive Waste
<b>Process</b>	Gasification
<b>Equipment</b>	Synthesis gas cooling and conditioning system, control system with man-machine interface and ancillary equipment, pumps, piping, structural steel, motors, motor controls.
<b>Main Product</b>	Electrical Energy
<b>By-Product</b>	Char

**Technical Description of Technology**

For this project, Primenergy provided a Model R-18 gasifier, the synthesis gas cooling and conditioning system, a process control system with man-machine interface and ancillary equipment, pumps, piping, structural steel, motors, motor controls, etc. The complete scope of supply was manufactured and major equipment was pre-assembled in Tulsa prior to overseas shipment.

The ultimate job site location is near an olive oil manufacturer located on the southern coast of Italy. Upon arrival in Italy, the gasification and cleaning system will be coupled to multiple turbo-charged engine driven electrical generators.

Primenergy dispatched a field representative to provide technical assistance in the construction and installation of the imported equipment. Start-up and commissioning of the integrated facility occurred in the spring of 2002. All of the electrical energy output from the conversion of the olive waste into energy will be sold to the national grid.

**Detailed Process Description**

Primenergy designs and manufactures a biomass gasification system. The gasification of biomass produces a hot (over 1,000° F) synthesis gas that contains combustible gases such as methane, hydrogen, carbon monoxide and others. However, in addition to this calorific content, the evolved gases contain ash and tar contaminants. Until recently, these contaminants presented a seemingly unsolvable problem. When consumed as a fuel in engines or turbines, their presence damages and debilitates internal moving surfaces of the engine or turbine.

Primenergy, after considerable expense and several years of research, development, testing and demonstration, invented on a novel, patented

synthesis gas cooling and conditioning process. Initial cooling of the gas is accomplished with an indirect gas cooler. This is followed by direct contact cooling. After the synthesis gases are sufficiently cooled, the gases are mechanically cleansed of any residual entrained ash and aerosol tars. Synthesis gases treated in the patented process are suitable as fuel for internal combustion devices.

### **Main Products**

Electrical Energy

### **Environmental Considerations**

However, in addition to this calorific content, the evolved gases contain ash and tar contaminants. Until recently, these contaminants presented a seemingly unsolvable problem. When consumed as a fuel in engines or turbines, their presence damages and debilitates internal moving surfaces of the engine or turbine.

### **Investment and Operating Cost**

At Primenergy's Tulsa location, there is a full commercial scale demonstration gasifier. This gasifier has been retro-fitted with the gas cooling and cleansing system. To demonstrate the proof of concept, olive waste from Italy was imported. An internal combustion engine was installed and operated under load.

### **Examples of Real Life Applications**

Olive Waste to Electrical Energy  
Project Location: Rossano, Italy

Gasification of 4.5 US Tons per Hour of Olive Waste with Electrical Power Generation, via Internal Combustion Engines, of over 4.0 Megawatts

### **Supplier:**

Primenergy, L.L.C

P O Box 581742 Tulsa Oklahoma 74158

Phone: (918) 835-1011 Fax: (918) 835-1058

### **Sources:**

1. [http://www.primenergy.com/Projects\\_detail\\_Rossano.htm](http://www.primenergy.com/Projects_detail_Rossano.htm)

## Low-cost 500 kW thermal rice hull combustion system<sup>54</sup> Netherlands, Commercial

<b>Crop</b>	Rice
<b>Residue</b>	Hull
<b>Process</b>	Combustion
<b>Equipment</b>	500kW oven
<b>Product</b>	Heat for industrial use

### Technical Description of Technology

BTG has developed a low-cost 500 kW thermal rice hull combustion system to generate heat for industrial heating. The two-stage system has been specifically designed for developing countries. The technology is interesting for its good performance, local manufacturing possibilities and its potential to substitute conventional fuels.

The system consists of the following main components:

- Feeding system ? Combustion chamber
- Air supply ? Heat exchanger
- Chimney

Rice hull enters the combustion chamber at the top and moves downward over a fixed hot bed by gravity. The two-stage technology refers to two air inlets ports; primary air is coming through small holes entering at the bottom of the bed. Secondary air enters above the bed and ensures complete combustion. Hot combustion gases are led through a heat exchanger and heats up ambient air to 100 – 200 .C dependent on the application. The resulting hot air is led into the dryers using existing or – if necessary – additional blowers.



Burning rice hull



Drying ovens in Costa Rica

<sup>54</sup> <http://www.btgworld.com/2005/pdf/technologies/leaflet-rice-hull-combustion.pdf>

For drying rice, like in Bolivia, the best results are obtained with high drying air flows (some 25,000 m<sup>3</sup>/hr) at low temperatures (leaving the oven at some 100 .C and further brought down by mixing with environment air to 60 .C).

### **Investment and Operating Cost**

Costs of one 500 kWth oven are around € 15,000 – 20,000, depending on local costs of materials and transport, costs of feeding system, dryer connection and necessity for additional air suction. Depending on costs of conventional fuels, the investment typically pays itself back in 2-3 years.

### **Examples of Real Life Applications**

The technology was first being used in Columbia and Costa Rica and has been further improved and tested in Bolivia. The technology is fully commercial available in Columbia and Costa Rica. BTG has improved the design and is currently introducing the oven together with local manufacturers in a number of other countries. By adjusting the secondary airflow, a wide range of temperatures can be maintained making the concept flexible for many applications. Design and construction of rice hull combustion oven for rice drying in Yapacani in Bolivia



Oven to dryers connection in Bolivian rice mill



Rice hull oven in Yapacani in Bolivia

### **Supplier**

Frans Feil  
BTG Biomass Technology Group BV  
PO Box 217  
7500 AE Enschede  
The Netherlands  
Tel. +31 (0) 53 489 28 97  
Fax.+31 (0) 53 489 31 16  
E-mail: [Feil@btgworld.com](mailto:Feil@btgworld.com)  
Web. [www.btgworld.com](http://www.btgworld.com)



## Kansai Carbonized Rice Husk Gasifier

Japan, Commercial

<b>Crop</b>	Rice
<b>Residue</b>	Husks
<b>Process</b>	Gasifier
<b>Equipment</b>	gasifier, scrubber, gas filter, and gasholder
<b>Main Product</b>	Electricity
<b>By-Product</b>	Ash

### Technical Description of Technology

The gasification system was developed to produce low calorific gas for electricity generation and at the same time to produce carbonized rice husk (CRH) or ash.

The basic design of the system consisted of gasifier, scrubber, gas filter, and gasholder. The system was coupled to the gas engine to drive an electric generator of 20 kW. The gasifier developed in the experiment was the updraft type with an automatic feeding hopper as shown in Figure 1.

Figure 1. Carbonized Rice Husk Gasifier

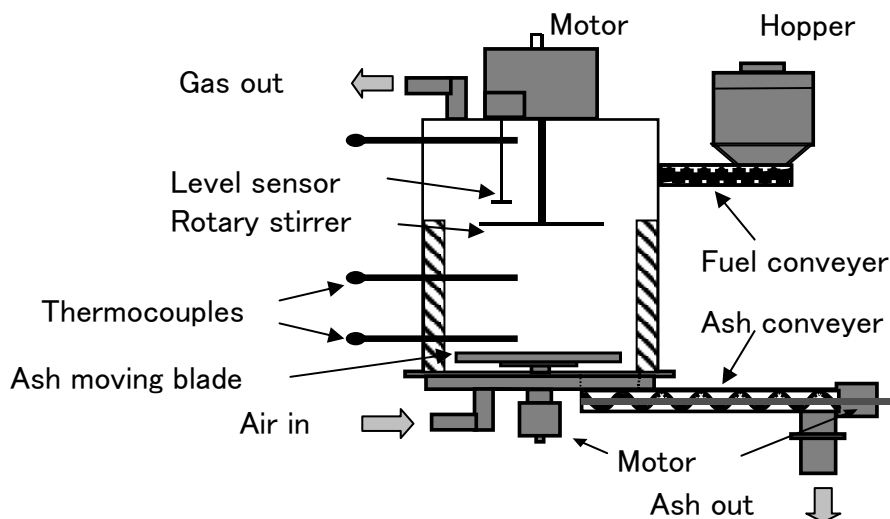

The lower part of gasifier was fabricated by refractory concrete with steel plating. The rice husk in the hopper was fed by the screw conveyor into the gasifier. A rotary stirrer driven slowly was used to have a uniform piling of rice husk to avoid uneven combustion. The rice husk was combusted in the lower part of the gasifier.

The gas introduced to the engine was found to be capable of producing 8-12 kW. The efficiency of gas conversion and electric conversion of rice husk was found to be 30 % and 8 % respectively. The rate of CRH conversion was 22 % in weight of rice husk input, which is equivalent to 30 % in terms of the energy contained in the rice husk.

### **Detailed Process Description**

In the gasification process, combustible gases were produced by burning the rice husk with restricted air supply through the bottom of the gasifier.

The blade moved ash into a hole on the fire lattice. Then screw conveyer carried the ash to the outlet. This device was used to lower the combustion zone and keep the combustion temperature to desired level by discharging ash or carbonized rice husk (CRH). The CRH was discharged 3-4 times per hour depending upon the temperature inside the gasifier.

The temperature measurements inside the gasifier were made by thermocouples, which were connected, to a data logger. Gas samples were collected from the gasholder for analysis of gas composition and heating value.

### **Main Products**

Electricity

### **Environmental Considerations**

The gasifier was equipped with ash discharging device at the bottom. This system consisted of the ash moving blades and the ash conveyer.

### **Investment and Operating Cost**

The electric power generated ranged 8-12 kW depending upon the operating condition. Gas temperature at the outlet of gasifier was 900C.

The CRH was discharged from the gasifier as needed. The CRH recovery rate was about 25 % depending upon the operating conditions. The CRH is being studied to mix with organic fertilizer for sustainable crop and vegetable production.

### **Examples of Real Life Applications**

ISSI Corporation, Kameoka City 621-0124, Japan  
Kansai Corporation, Hikone City 522-0222, Japan  
PhilRice, Science City of Munoz, Nueva Ecija 3119, Philippines

### **Sources:**

1. NEDO AAAE technical paper

## Colusa Rice Straw / Hulls Technology<sup>55</sup> USA, Commercial

<b>Crop</b>	Rice
<b>Residue</b>	Straw and Husk
<b>Process</b>	Fermentation, Distillation
<b>Equipment</b>	Bio-refinery system
<b>Main Product</b>	Fuel Ethanol
<b>By Products</b>	Silica, Metal Finishing, Water Soluble Oil & Synthetic Lubricant Coolants, Latex and Latex Paint, Pulp and Paper, Chemical & Metallurgical, Textile & Dye.

### Technical Description of Technology<sup>56</sup>

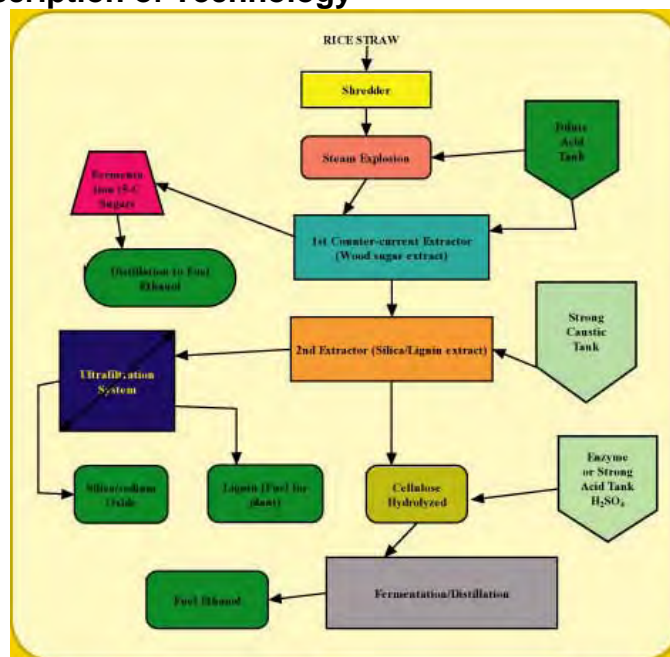

\*Green boxes are valuable secondary plant products

<sup>55</sup> <http://www.colusabiomass.com/straw.htm>

<sup>56</sup> *ibid*

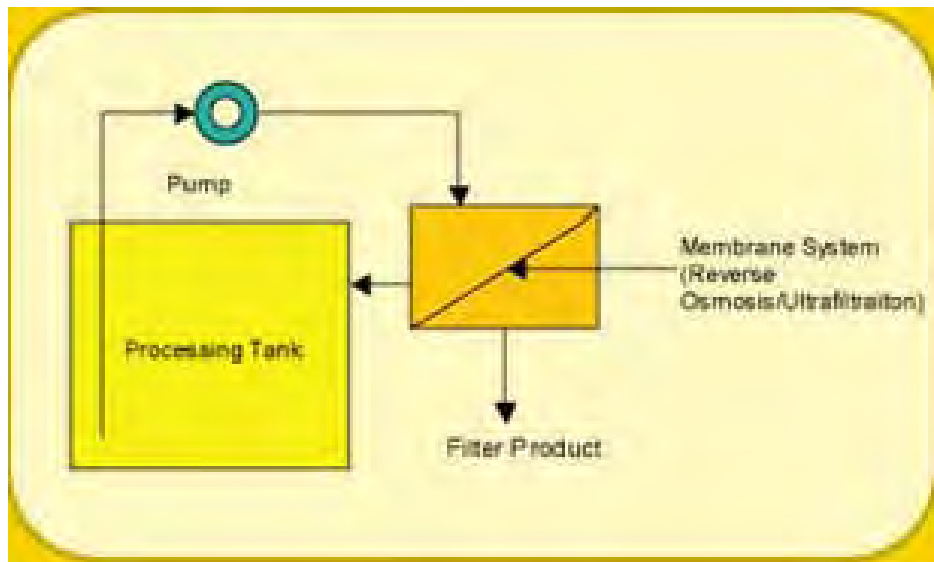

### Detailed Process Description<sup>57</sup>

1. Rice straw/hulls pass through a shredder
2. Shredded material passes to a steam explosion where dilute sulfuric acid is added to the material
3. The material then passes to a counter current extractor containing NaOH solution. This process will place the silica and the lignin in solution
4. The lignin-silicate solution passes to our ultrafiltration system where the silicate solution passes through the membrane and the lignin solution is concentrated
5. The material leaving the counter-current extractor is washed and hydrolyzed, fermented and converted to fuel ethanol, or
6. The lignin fuel separated by the ultrafiltration system is used to provide energy for the operation of the plant.

### Operation and Maintenance Requirements<sup>58</sup>

Colusa facility consumes approximately 130,000 tons of waste biomass annually, producing 12.5 million gallons of ethanol and 16,800 tons of silica/sodium oxide.

### Environmental and Social Considerations<sup>59</sup>

Uses low cost plant waste rather than high-cost corn and grain to produce ethanol for fuel and various by-products such as lignin and silica. Highly efficient fermentation steps produce only trace amounts of CO<sub>2</sub>. Simply leaving the straw on the ground for soil nutrition requires chopping it up and re-flooding the fields with water.

### Investment and Operating Cost

The company bought a patent—U.S. Patent No. 5,735,916 in October 2004, with the \$40 million cost of capitalizing this relatively small facility, decided to take the company public.<sup>60</sup>

<sup>57</sup> [ibid.](#)

<sup>58</sup> <http://www.colusabiomass.com/news.htm>

<sup>59</sup> [http://www.ethanolproducer.com/article.jsp?article\\_id=3175](http://www.ethanolproducer.com/article.jsp?article_id=3175)

The customized harvester collects the waste, bursts the straw's cylindrical tubes and chops it into 3/8-inch pieces. The material is blown into trailers that hold from nine to 14 tons and it is transported to one of company's three satellite storage facilities. These storage sites have a harvesting radius of approximately 17 miles each and are located to the north, east and south of the biorefinery project location.<sup>61</sup>

### **Economic instruments for overcoming barriers<sup>62</sup>**

Several hundred million dollars in grant money the U.S. DOE has awarded to ethanol producers to develop commercial cellulosic technologies. The state of California also has specific grant money available for the utilization of rice straw.

### **Advantages to Developing Countries<sup>63</sup>**

Ideal for an organization that produces and must dispose of plant waste, or that has a cheap local supply of plant waste from others who must dispose of it.

- High ethanol yield per ton of feed stock [94 gallons].
- Low cost of feedstock [waste straw].
- Feed stock most plentiful in world [800,000,000 tons annually].
- Low production costs of ethanol.
- Two income streams: ethanol and silica sodium oxide.
- No feed stock taken from food stream, all are Ag wastes and residues.

### **Examples of Real Life Applications**

**Level of Use:** Commercial Use  
**Name of Project:** Colusa Rice Straw / Hulls Technology  
**Location:** Colusa Biomass Energy Corporation  
California, USA

### **Suppliers<sup>64</sup>**

Colusa Biomass Energy Corp.  
1023 Main Street  
Colusa CA, 95932  
Telephone: 530.458.8101  
Fax: 530.458.8106

---

<sup>60</sup> [http://www.ethanolproducer.com/article.jsp?article\\_id=3175&q=&page=2](http://www.ethanolproducer.com/article.jsp?article_id=3175&q=&page=2)

<sup>61</sup> [http://www.ethanolproducer.com/article.jsp?article\\_id=3175](http://www.ethanolproducer.com/article.jsp?article_id=3175)

<sup>62</sup> *ibid.*

<sup>63</sup> [http://www.colusabiomass.com/news/Colusa-County-Sun-Herald\\_Chinese-delegation-visits-Colusa.pdf](http://www.colusabiomass.com/news/Colusa-County-Sun-Herald_Chinese-delegation-visits-Colusa.pdf)

<sup>64</sup> <http://www.colusabiomass.com/contact.htm>



## **Rice Husk Gasifier Philippines, Commercial**

<b>Crop</b>	Rice, Corn and other agriwaste
<b>Residue</b>	Husk, corncobs
<b>Process</b>	Gasification
<b>Equipment</b>	Gasifier Combustor
<b>Main Product</b>	Heat, fuel
<b>By-Product</b>	

### **Technical and Process Description of Technology:**

The ITDI rice hull gasifier combustor has the following major parts:

1. Air delivery system - air is introduced inside the gasifier reactor through a pipe using an electric centrifugal blower.
2. Reactor body - the reactor contains the rice hull being gasified and where the gasification reaction occurs. This is made of B.I plate insulated by ordinary red bricks.
3. Fuel feeding system - the gasifier fuel inlet assembly is located at the topmost section with reactor, feeding is done by pouring the rice hull into the reactor. To avoid air leaks, the cover of hopper is tightly locked after the feeding.
4. Grate and ash removal system - Ash is removed after each batch of operation. This is done by opening the bottom cover, and pulling out the grate out of the reactor, and ash residue fall down to the ash can.

To start it up, burn 3 kg of charcoal that will serve as the starter for the gasifier. Drop the burning charcoal on top of the grate. Make sure that charcoal is properly scattered through out the grate surface so that fuel will be evenly burned. For the succeeding batch of operation, burned charcoal is no longer needed. Dry wood chips and coconut husk can also serve as starter for combustion.

### **Main Products:**

To date a total of 95 units of ITDI rice hull gasifier combustor have been installed in different locations around the country, through different applications such as heat source for palay drying, traditional bakery oven, citronella extraction, candle making, bagasse processing, noodle toasting, noodle frying, cornick production, brick & pottery making, micro dressing plant, and other similar thermal equipment using woodfuel or fuel oil.

To convert the existing thermal equipment using woodfuel or fuel oil into a gasifier one, the nozzle of gas/flame pipe of gasifier combustor is retrofitted directly to the firebox of the system.

### **Social Considerations**

The use of this technology is a profitable method of disposing bio-mass fuel particularly rice hull, which are often burned or left to rot in dumpsite causing clogged stream and waterways. As a substitute for wood fuel, massive cutting of trees can be controlled. This would prevent depletion of our forests, which is causing heavy floods in various parts of the country.

### **Investments and Operating Cost**

Total Project Cost: P 3,022,800  
Financing Scheme (Equity): 100%  
Unit Production Cost/unit: P 21,639.36  
Commercial Price/unit/Selling Price/unit: P 25,000  
Return on Investment (IRR): 38%  
Cash Payback period (yrs): 2.5

### **Advantages to Developing Countries**

There are advantages of using the combustor over direct burning of biomass fuel. The combustor is capable of producing clean gas/flame. Temperature control is easier when utilizing solid biomass fuel. The combustor is designed in such a way that it can be conveniently installed to any type of existing furnace, palay drier, boiling vessel, traditional bakery oven and other similar thermal equipment using woodfuel or fuel oil.

### **Examples of Real Life Applications**

Industrial Technology Development Institute (ITDI)  
DOST Complex, Gen. Santos Ave., Bicutan, Taguig, Metro Manila  
Phone: 8372071 to 82 loc 2182  
Fax: 8373167  
Web Site: <http://mis.dost.gov.ph/itdi>  
E-mail: [admhrd@dost.gov.ph](mailto:admhrd@dost.gov.ph)

### **Sources:**



## 2.5 MW Cogeneration Plant<sup>65</sup> Thailand, Commercial

<b>Crop</b>	Rice
<b>Residue</b>	Husk
<b>Process</b>	Combustion
<b>Equipment</b>	Boiler
<b>Main Products</b>	Super heated steam to generate hot water for paddy dryers

### Production Capacity

- a step grate/boiler producing 17 tonnes of superheated steam at 35 bar and equipped with automatic ash removal system;
- a 2.5 MW multi-stage fully condensing turbo-generator

### Detailed Process Description

- a rice husk silo, a conveying and automatic boiler feeding system;
- a step grate/boiler producing 17 tonnes of superheated steam at 35 bar and equipped with automatic ash removal system;
- a 2.5 MW multi-stage fully condensing turbo-generator;
- heat exchangers using boiler flue gas and/or superheated steam to generate hot water for paddy dryers.

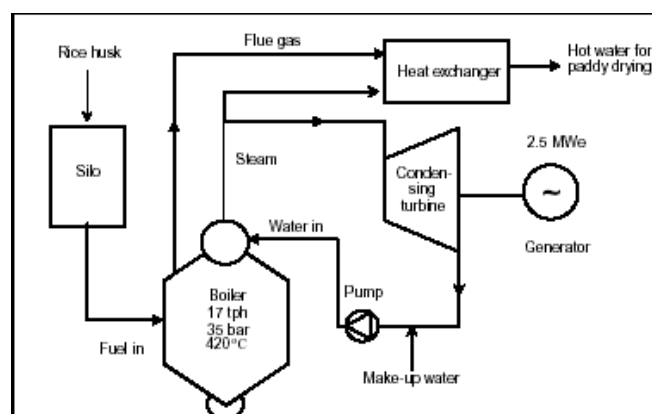

### Price of Machine

The total investment cost of the project was Euro 3.6 million, excluding civil works and building structures.

### GHG Emission Reduction Potential

Total GHG avoided by implementing this rice husk boiler is around 7,000 tonnes of CO<sub>2</sub> equivalent per year.

<sup>65</sup> <http://www.cogen3.net/doc/articles/CleanandefficientbiomassCogeneration.pdf>

### **Examples of Real Life Applications**

Commercial      Chia Meng Rice Mill 2.5 MW cogeneration plant Nakhon  
Ratchasima  
Province, Thailand

## San San Rice Husk Stove Myanmar, Commercial

<b>Crop</b>	Rice, fresh biomass, etc.
<b>Residue</b>	Rice Husks, chopped kitchen wastes, leaves and fresh biomass
<b>Process</b>	Smokeless combustion
<b>Equipment</b>	Gasifier
<b>Main Product</b>	Fuel for household cooking

### Technical Description of Technology:<sup>66</sup>

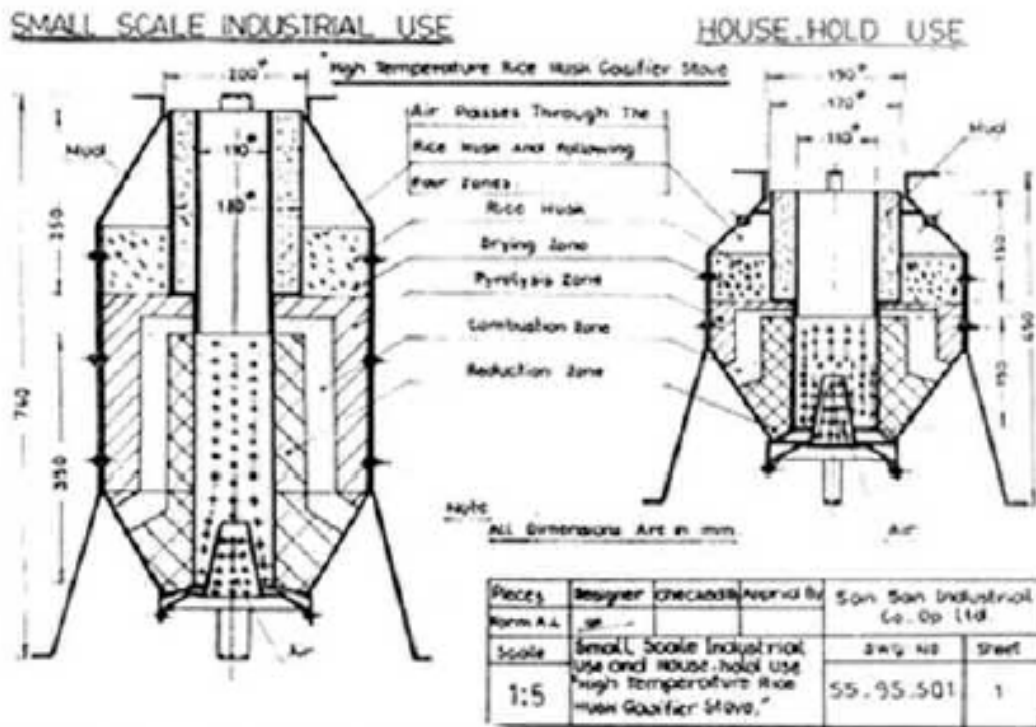

Figure 1. San San Rice Husk Stove

San San Industrial Cooperative Ltd. of Myanmar, with support from the Indian Institute of Technology, has devised a rice husk gasifier stove for smokeless combustion of rice husk. The path of air flow in the new stove is from the top to the bottom. Air passes from the rice husk portion at the top of the stove through the drying, pyrolysis, combustion and reduction zones, creating gas and char/ash by this reverse air flow system. Holes are provided for air flow and a hinged shutter aids char or ash removal.

<sup>66</sup> [http://www.techmonitor.net/techmon/03sep\\_oct/nce/nce\\_biomass.htm](http://www.techmonitor.net/techmon/03sep_oct/nce/nce_biomass.htm)

Primary air flows directly into the producer gas burning zone at the bottom of the stove through air passage holes. Secondary air from the top passes through the four zones. In the drying zone, the temperature is just adequate to remove moisture present in the rice husk, but not high enough to initiate any chemical reaction. The organic structure of rice husk is broken down in the pyrolysis zone, through heat released from the combustion zone. Products of the pyrolysis step are water vapour, methanol, acetic acid, heavy hydrocarbon, tars and carbon. In the combustion zone, oxidation of carbon to produce carbon dioxide (CO<sub>2</sub>) is the main chemical reaction.

The gas being processed passes through carbon in the high temperature reduction zone to change into producer gas. From the set of reactions in the reduction zone, the most important is that in which CO<sub>2</sub> from the combustion zone is converted to carbon monoxide. Producer gasification can be improved by adding biomass, including potato peels and green stems of flowers or vegetables, which are dried along with rice husk in the drying zone.

#### **Detailed Process Description:<sup>67</sup>**

The stove burns rice husks directly by allowing the air to pass through the perforated bottom of the stove going to the top. The primary air flows directly in the producer gas burning zone at the bottom of the stove. A hinge shutter allows the removal of ash as necessary. The secondary air passes through the four zones of the stove. The stove can also be fueled with a mixture of chopped kitchen wastes, leaves and fresh biomass, and rice husks. The problem of frequent tapping the ash in the stove is minimized and the smoke emitted was found to be negligible and less polluting as reported.

#### **Operation and Maintenance Requirements:**

The most significant cost element is the quality and quantity of feedstock. The demand of feedstock should not disrupt markets for agricultural commodities. Process utilities and transportation should be able to support the scale of production.

#### **Social Considerations<sup>68</sup>**

Exposure to smoke from indoor biomass burning is known to cause acute respiratory infection and chronic lung disease. As pointed out by Kammen (1999), some studies have also linked smoke to an increased incidence of eye infections, low birth weight and cancer. Considering the severity of indoor air problem, Reddy et al. (1997) cautions because a large portion of the population is exposed, the total indoor air pollution exposure (from domestic biomass combustion) is likely to be greater for most pollutants than from outdoor urban pollution in all the world's cities combined. The stove's simple design facilitates easy fabrication.

#### **Investments and Operating Cost<sup>69</sup>**

---

<sup>67</sup> [http://www.crest.org/discussiongroups/resources/stoves/Belonio/Belonio\\_gasifier.pdf](http://www.crest.org/discussiongroups/resources/stoves/Belonio/Belonio_gasifier.pdf)

<sup>68</sup> <http://www.retsasia.ait.ac.th/Publications/An%20Improved%20Gasifier%20Stove%20for%20Institutional%20Cooking.pdf>

<sup>69</sup> <http://www.dede-acmeccs.com/ENGLISH/Lao4/sum-lao4-eng.html>

The technology of rice husk gasifier could be effectively used in households which were agreed with the spread of husks that were all over the places. In Lao, the economic value of rice husk gasifier is compared to that of LPG stove. The study of the economic value is done based on 5 year lifetime of the gasifier. The cost of 15 kg LPG is 350 Baht. The fuel consumed per year of the gasifier is equivalent to 6 units of 15 kg LPG. As the cost of gasifier is 5,000 Baht per unit, the savings on LPG is 3,600 Baht per year, resulting in 1.4 years of payback period and 61.95% IRR.

### **Advantages to Developing Countries<sup>70</sup>**

According to a recent study, the total potential of saving biomass used for domestic cooking through substitution of the traditional stoves by improved ones in six Asian countries (China, India, Nepal, Pakistan, Philippines and Sri Lanka) is about 277 million tons/year (Bhattacharya et. al, 1999); the saving amounts to about 36% of the biomass consumption for cooking in these countries at present.

### **Examples of Real Life Applications**

San San Industrial Cooperative Ltd.  
279, Shwegondine Road, Bahan Township,  
Yangon, Myanmar (Burma).  
Tel: (+95-1) 554957 extension - 28

---

<sup>70</sup><http://www.retsasia.ait.ac.th/Publications/An%20Improved%20Gasifier%20Stove%20for%20Institutional%20Cooking.pdf>

## ITDI Rice Hull Gasifier<sup>71</sup> Philippines, Commercial

<b>Crop</b>	Rice, corn, coffee, etc.
<b>Residue</b>	Rice hull, corncobs, coffee hulls and similar biomass materials
<b>Process</b>	Gasification
<b>Equipment</b>	Industrial Technology Development Institute Rice Hull Gasifier
<b>Main Product</b>	Heat

### Technical and Process Description of Technology:

The ITDI rice hull gasifier combustor has the following major parts:

5. Air delivery system - air is introduced inside the gasifier reactor through a pipe using an electric centrifugal blower.
6. Reactor body - the reactor contains the rice hull being gasified and where the gasification reaction occurs. This is made of B.I plate insulated by ordinary red bricks.
7. Fuel feeding system - the gasifier fuel inlet assembly is located at the topmost section with reactor, feeding is done by pouring the rice hull into the reactor. To avoid air leaks, the cover of hopper is tightly locked after the feeding.
8. Grate and ash removal system - Ash is removed after each batch of operation. This is done by opening the bottom cover, and pulling out the grate out of the reactor, and ash residue fall down to the ash can.

To start it up, burn 3 kg of charcoal that will serve as the starter for the gasifier. Drop the burning charcoal on top of the grate. Make sure that charcoal is properly scattered through out the grate surface so that fuel will be evenly burned. For the succeeding batch of operation, burned charcoal is no longer needed. Dry wood chips and coconut husk can also serve as starter for combustion.

To convert the existing thermal equipment using woodfuel or fuel oil into a gasifier one, the nozzle of gas/flame pipe of gasifier combustor is retrofitted directly to the firebox of the system.

### Social Considerations

The use of this technology is a profitable method of disposing bio-mass fuel particularly rice hull, which are often burned or left to rot in dumpsite causing clogged stream and waterways. As a substitute for wood fuel, massive cutting

---

<sup>71</sup> [http://setup.dost.gov.ph/c\\_commerce.php?view=219](http://setup.dost.gov.ph/c_commerce.php?view=219)

of trees can be controlled. This would prevent depletion of our forests, which is causing heavy floods in various parts of the country.

### **Investments and Operating Cost**

Total Project Cost: P 3,022,800

Financing Scheme (Equity): 100%

Unit Production Cost/unit: P 21,639.36

Commercial Price/unit/Selling Price/unit: P 25,000

Return on Investment (IRR): 38%

Cash Payback period (yrs): 2.5

### **Advantages to Developing Countries**

There are advantages of using the combustor over direct burning of biomass fuel. The combustor is capable of producing clean gas/flame. Temperature control is easier when utilizing solid biomass fuel. The combustor is designed in such a way that it can be conveniently installed to any type of existing furnace, palay drier, boiling vessel, traditional bakery oven and other similar thermal equipment using woodfuel or fuel oil.

### **Examples of Real Life Applications**

To date a total of 95 units of ITDI rice hull gasifier combustor have been installed in different locations around the country, through different applications such as heat source for palay drying, traditional bakery oven, citronella extraction, candle making, bagasse processing, noodle toasting, noodle frying, cornick production, brick & pottery making, micro dressing plant, and other similar thermal equipment using woodfuel or fuel oil.

Industrial Technology Development Institute (ITDI)

DOST Complex, Gen. Santos Ave., Bicutan, Taguig, Metro Manila

Phone: 8372071 to 82 loc 2182

Fax: 8373167

Web Site: <http://mis.dost.gov.ph/itdi>

E-mail: [admhrd@dost.gov.ph](mailto:admhrd@dost.gov.ph)

**PADISCOR Rice Hull Cylconic Furnace  
Philippines, Commercial**

<b>Crop</b>	Rice
<b>Residue</b>	Hulls
<b>Process</b>	Combustion
<b>Equipment</b>	Furnace
<b>Main Product</b>	Heat for crop drying

**Technical Description of Technology:<sup>72</sup>**

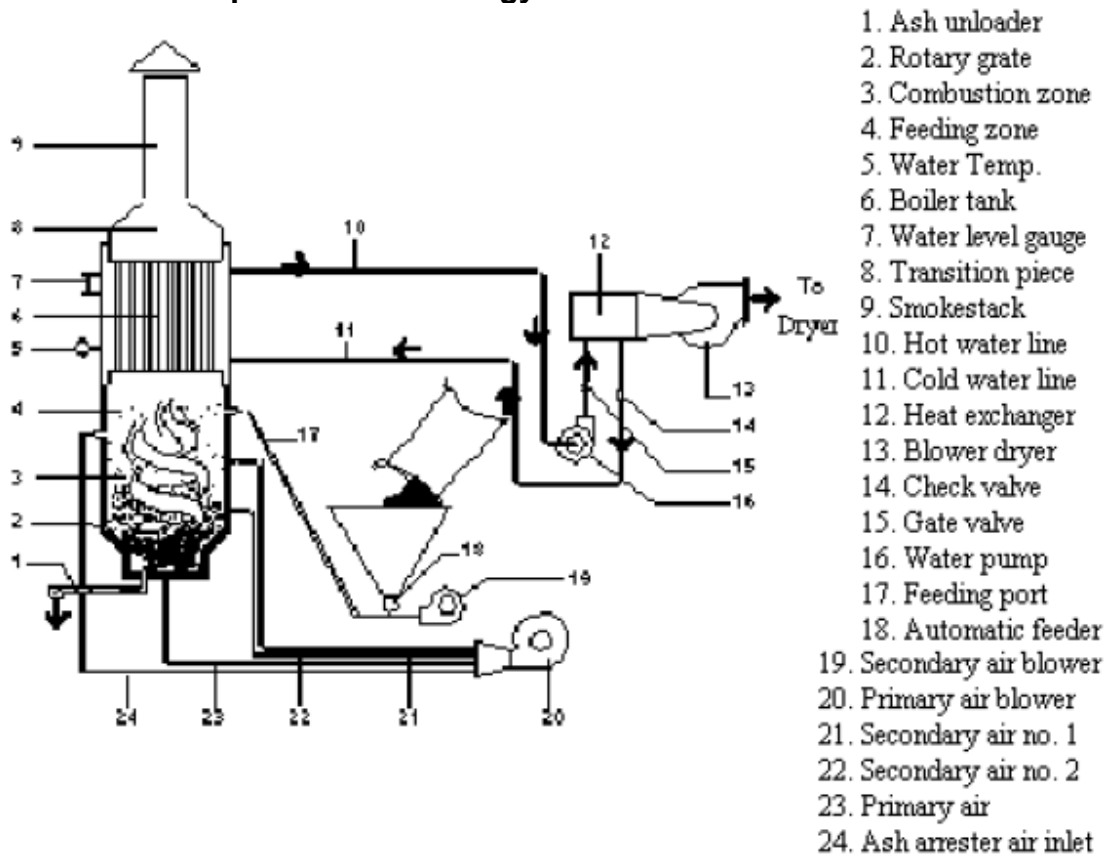

Figure 1. Rice Hull Cyclonic Furnace

Rice hulls are fed into the furnace (Fig. 1) in a cyclonic motion inside the combustion chamber. The cyclonic motion allows the rice hulls to be burned while in suspension. Suspension burning of rice hulls allows the separation of its ash from the air, thus producing a clean flue gas. The flue gas is released on top of the furnace and directed to a fire tube hot water heat exchanger. The hot water is then pumped to another hot water – air heat exchanger where drying air is passed through before the drying plenum. The furnace

<sup>72</sup> <http://www.bpre.gov.ph/scripts/cornmecfinder.asp?categ=13>



includes an automatic feeder, which controls the fuel carried by air jet and injected tangentially inside the combustion chamber. A rotating grate at the bottom of the furnace discharges the ash continuously at the rate synchronized with the fuel feed rate. Three air inlets strategically located along the periphery of the furnace provide secondary air for better combustion efficiency and temperature control. It reduces the risk of overheating the furnace and at the same time avoids the crystallization of the ash.

The furnace has a grate surface area of 0.203 m<sup>2</sup> and a combustion space volume of 0.514 m<sup>3</sup>. It is constructed mainly out of 12.7 cm thick refractory firebricks and enclosed by 0.48 cm thick mild steel plates. An automatic feeder coupled with 2.55 m<sup>3</sup>/min centrifugal blower feeds the rice hull.

Combustion air is supplied by a 4.53 m<sup>3</sup>/min centrifugal blower through three ports.

#### **Detailed Process Descriptions:**

1. Biomass fuel is feed into the furnace in cyclonic motion inside the combustion chamber.
2. The cyclonic motion allows the biomass fuel to be burned while in suspension.
3. Suspension burning of the biomass fuel also allows separation of the ash of combustion from the air thus producing a pollution-free flue gas.
4. Water is heated by the fire-tube boiler
5. The hot water is pumped to the hot water heat exchanger where the drying air is passed through before the drying column.

#### **Operation and Maintenance Requirements:<sup>73</sup>**

1. It must provide uniform feeding of rice hull for uniform combustion.
2. Primary air and secondary air must be provided at certain ratio to provide complete combustion of rice hull. Assumed ratio of primary to secondary air is 25/75 to 35/65.
3. Excess air of over 60 percent is recommended.
4. Ash must be discharged at regular rate to prevent clogging of the combustion chamber. Ash disposal must be synchronized with fuel feeding.
5. Grate area must be 50 to 60 kg/h.m<sup>2</sup> or 840 MJ/h.m<sup>2</sup>.
6. Combustion chamber volume must be 40 to 60 kg/h.m<sup>3</sup> or 840 MJ/h.m<sup>3</sup>.

The biomass furnace that was developed can consume an average of 39 kg of rice hull per hour. Estimated overall thermal efficiency is 61 percent. The average burning efficiency obtained was 96.7%. The relatively high burning efficiency of the furnace may be due to the longer retention time of the char in the grate and sufficient supply of combustion air.

#### **Social Considerations**

---

<sup>73</sup> <http://www.retsasia.ait.ac.th/Publications/WREC%202000-UPLB.pdf>

The furnace required less labor compared to the traditional rice hull step-grate furnaces. Labor was needed only in loading the rice hull into the feed hopper. Resource assessment made on rice hull indicated that there are a number of rice mills where the drying plant can get fuel.

### **Advantages to Developing Countries**

Most if not all of the mills dispose the hulls along the highway. However, after the commissioning of the plant, millers started selling their rice hulls instead of giving it for free. The rice hull cyclonic furnace that was developed can also be used in the rural areas to provide heat for crop drying. It can be modified according to the heat load requirement of the clientele.

### **Examples of Real Life Applications**

Manufacturer: PADISCOR  
Supplier: Pasig Agr'l Dev't. & Ind'l Supply Corp  
Address: 1 Lopez Jaena St. Kapasigan, Pasig  
City  
Telephone No: 916-0701; 643-5736; 641-1804

## **Maligaya Rice Hull Stove<sup>74</sup>** **Philippines, Commercial**

<b>Crop</b>	Rice
<b>Residue</b>	Hull
<b>Process</b>	Combustion
<b>Equipment</b>	Maligaya Rice Hull Stove
<b>Main Product</b>	Heat for cooking

### **Technical Description of Technology**

Developed by the Philippine Rice Research Institute. The current design is an improvement of Vietnamese and Indonesian rice hull stoves. After testing their performance with other rice hull stove designs (local and foreign), both stoves were found to possess outstanding features that were incorporated in this new design. It is environment-friendly, practically smokeless, ignites after 36 seconds after dropping a burning paper, consumes 1 kg of rice hull per hour, can reach a temperature of around 600-700°C for 15 minutes and one load can continuously burn for 28 min, enough to cook rice and vegetable viand for a household of five members.



### **Example of Real Life Application**

Commercial Philippines

### **Supplier**

PhilRice, Science city of Munoz, Nueva Ecija  
Philippines

---

<sup>74</sup> <http://www.philrice.gov.ph/machinery/stove.htm>

## TSerong Cogeneration Plant<sup>75</sup> Malaysia, Commercial

<b>Crop</b>	Rice
<b>Residue</b>	Husk
<b>Process</b>	Combustion
<b>Equipment</b>	Combi-Boiler
<b>Main Product</b>	Electricity and Heat
<b>By-Product</b>	High quality ash is produced as by-product.

### Technical Description of Technology

The plant consists of:

- a rice husk firing system with a combi-boiler generating 12 tonnes of superheated steam at 25 bar (a) and 300 0C;
- an extraction-condensing turbine coupled to a 1.5 Mwe alternator;
- a complete system for conveying and storage of rice husk ash.

### Detailed Process Description<sup>76</sup>

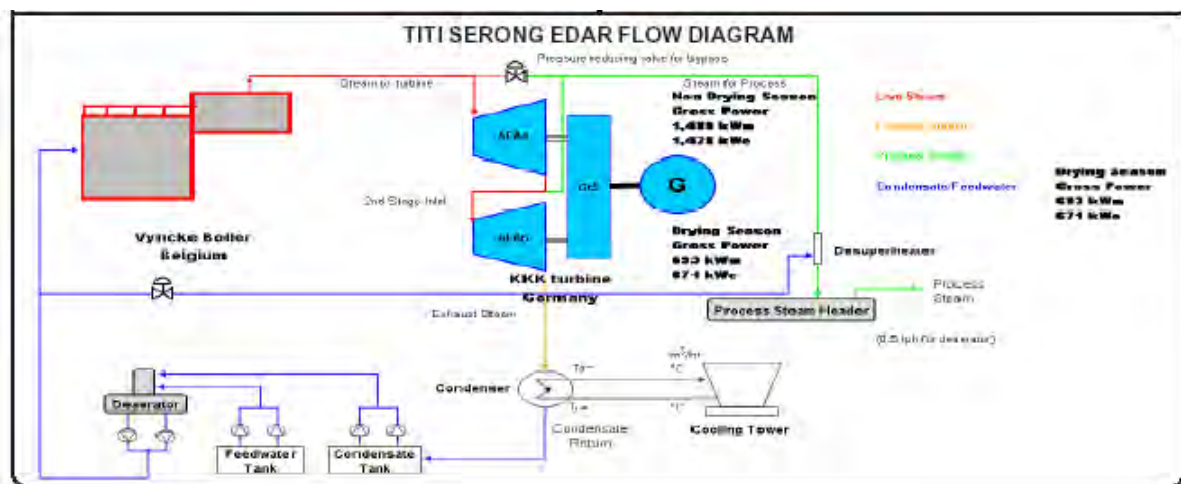

### Job Potential<sup>77</sup>

The addition of a new 10-tonnes per hour high quality rice mill to the present parboiling plant of Titi Serong Edar Sdn. Bhd has led the management to invest in the new cogeneration plant. It generates between 700 and 1500 kW of electricity and low-pressure steam for the process.

<sup>75</sup> <http://www.cogen3.net/doc/articles/ImplementingBiomassCogenASEAN.pdf>

<sup>76</sup> <http://www.biomatnet.org/publications/2032br.pdf>

<sup>77</sup> [www.serid.ait.ac.th/cogen/62/campaign/3titi%20serong-final.pdf](http://www.serid.ait.ac.th/cogen/62/campaign/3titi%20serong-final.pdf)

### **Parameters for Procurement Specifications**

The plant was engineered and supplied by Vyncke NV (Belgium) and KKK GmbH Germany). The expected pay back period is about 3.5 years after commissioning.

### **Operation and Maintenance Requirements**

For a 16 tonnes per hour rice mill, with seasonal demand for process heating and power throughout the year, the technology was cost effective in taking care of both the seasonal imbalance of heat and power demand.

### **Specific Considerations for Developing Countries**

#### **Financing Considerations**

The main obstacle is a lack of awareness of benefits of cogeneration among the industry, policymakers and financiers.

### **Environmental Considerations**

It has a KKK twin extraction-condensing steam turbine. The flexibility of this system is that it can run in extraction-condensing mode to supply heat and power during the drying season, but can also run in a fully condensing mode for power generation alone during the non-drying season. The heat load changes need a customized solution for the cooling system to cater for heat load changes in the condenser during these two modes of operation.

### **Social Considerations<sup>78</sup>**

The cogeneration plant enables the operation of the rice mill at its peak capacity. The competitive advantage of the plant is definitely enhanced as it gets reliable and steady power and steam supply from the cogeneration plant. With the latter, the management solved the rice husk disposal problem. Moreover, it replaces the current supply of electricity from the grid and current supply of steam using diesel-fired boilers.

### **Investment and Operating Cost<sup>79</sup>**

The total investment cost amounts to Euro 1.65 million, excluding civil works and building foundations. The expected pay back period is about 3.5 years after commissioning.

### **GHG Emission Reduction Potential<sup>80</sup>**

The boiler efficiency was found to be around 70%, based on the LHV of the rice husk at a boiler load of 55%. The system includes the conveying system and storage of rice husk ash. The gross cogeneration efficiency during the non-drying season was 34%. Thus, it is estimated that the net greenhouse gas (GHG) emission reduction resulting from the process is equivalent to 7,900 tonnes

of CO<sub>2</sub>. The CO, NO<sub>x</sub>, SO<sub>x</sub> and particulate emissions are well below the allowable limits set by the Malaysian Authorities. Ash and waste water are properly disposed.

---

<sup>78</sup> [ibid](#)

<sup>79</sup> <http://www.biomatnet.org/publications/2032br.pdf>

<sup>80</sup> [www.serid.ait.ac.th/cogen/62/campaign/3titi%20serong-final.pdf](http://www.serid.ait.ac.th/cogen/62/campaign/3titi%20serong-final.pdf)

### **Economic instruments for overcoming barriers**

A pre-tax IRR of 39 % (with a payback period of 3.7 years) was obtained based on the revised investment and operating costs and potential energy saving figures. With a Net Present Value of Euro 5,406,000, the project appears highly viable. The decrease in the total project costs and the increase in the value of electricity and steam sold to the host rice mill resulted in a better profitability and a shorter payback.

### **Advantages to Developing Countries<sup>81</sup>**

Cogeneration is an efficient way to simultaneously produce electricity and heat from a single primary source (gas or fuel). At present, most of the heat generated by generators or machines is merely wasted as it is released into the air. Cogeneration technology captures and harnesses the heat from the machines and re-channels the energy to generate electricity or for heating purposes, eliminating the need for industries to buy expensive heaters.

### **Examples of Real Life Applications**

Commercial

Titi Serong Cogeneration Plant  
Malaysia

### **Suppliers<sup>82</sup>**

These European companies include Vyncke nv (Belgium) for the boiler, KKK (Germany) for the turbine and Cimbria A/S (Denmark) for the complete power plant erection and installation, as well as the supply of the drying, storage and conveying systems.

#### **BOILER MAIN OFFICE:**

Vyncke Energietechnik NV  
Gentsesteenweg, 224, B-8530 Harelbeke, BELGIUM  
Tel: +32 56 730 630  
Fax: +32 56 704 160

#### **LOCAL REPRESENTATIVE:**

Vyncke (East Asia) Sdn Bhd  
No. 10, Section 14/44, 46100 Petaling Jaya, MALAYSIA  
Tel: +603 7954 1408  
Fax: +603 7954 1409

#### **TURBINE MAIN OFFICE:**

AG Kuhnle, Kopp & Kausch (KKK)  
D-67227 Frankenthal, GERMANY  
Tel: +49 6233 852446  
Fax: +49 6233 852660

#### **AUTHORISED DEALER:**

Jebsen & Jessen Technology (M) Sdn Bhd  
16, Jalan 51A/225, 46100, Petaling Jaya, Selangor Darul Ehsan, MALAYSIA  
Tel: + 603 7876 9333  
Fax: + 603 7877 1033

---

<sup>81</sup> <http://www.biomatnet.org/publications/2032br.pdf>

<sup>82</sup> <http://www.biomatnet.org/publications/2032br.pdf>



## **Rice-Husk Based Gasifier<sup>83</sup>** **India, Commercial**

<b>Crop</b>	Rice
<b>Residue</b>	Husk
<b>Process</b>	Gasification
<b>Equipment</b>	Biomass gasifier
<b>Main Product</b>	Electricity

### **Description**

Biomass gasifiers capable of producing power from a few KW up to 1 MW capacity have been successfully developed indigenously.

- Indigenously developed small biomass gasifiers have successfully undergone stringent testing abroad.
- Biomass Gasifiers are now being exported not only to developing countries of Asia and Latin America, but also to Europe and USA.
- A large number of installations for providing power to small-scale industries and for electrification of a village or group of villages have been undertaken.
- The [Biomass Gasifier Programme](#) has been re-casted to bring about better quality and cost effectiveness.
- The programmes on biomass briquetting and biomass production are being reviewed and a new programme on power production linked to energy plantations on waste lands is proposed to be developed.

---

<sup>83</sup> <http://mnes.nic.in/po5.htm>





a 100KW capacity Rice-Husk based Gasifier installed in a rice mill in Andhra Pradesh

## Examples of Real Life Applications

### Installations:

- A total capacity of 55.105 MW has so far been installed, mainly for stand-alone applications.
- A 5 x 100 KW biomass gasifier installation on Gosaba Island in Sunderbans area of West Bengal is being successfully run on a commercial basis to provide electricity to the inhabitants of the Island through a local grid.
- A 500 KW grid interactive biomass gasifier, linked to an energy plantation, has been commissioned under a demonstration project.
- A 4X250 kW (1.00 MW) Biomass Gasifier based project has recently been commissioned at Khtrichera, Tripura for village electrification.

### Suppliers

#### Gasifier Systems Manufacturers

M/s. Ankur Scientific Energy Technologies Pvt. Ltd.,  
Near Old Sama Jakat Naka,  
Vadodara - 390 008.  
Telephone: 793098, 794021.  
Fax: 0265-794042.

M/s. Associated Engineering Works,  
PB No. 17, Chivatam Road,

Tanuku - 534 211.  
Telephone: 08819 - 22950  
Fax: 08819-24801.

M/s. Cosmo Products,  
Devpuri, Opp. Jain Public School,  
Dhamtari Road, Raipur - 492 015.  
Telephone: 0771 - 226927,  
Fax: 0771 - 226927.

M/s. Grain Processing Industries (India) Pvt. Ltd.,  
29, Strand Road, Calcutta - 700 001.  
Telephone: 033-2431639,  
Fax: 033-2204508.

Netpro Renewable Energy (India) Ltd.,  
139/B, 10<sup>th</sup> Main, Rajamahal Vilas Extension,  
Bangalore - 560 080.  
Telephone: ++91 80 3360 202.  
Fax NO: ++ 91 80 3360 199.  
E-mail : [netpro@blr.vsnl.net.in](mailto:netpro@blr.vsnl.net.in)

M/s. Electrotech  
E61-Industrial Phase III  
SAS Nagar Mohali  
Chandigarh

The Energy Resource Institute,  
Darbari Seth Block, Indian Habitat Centre,  
Lodhi Road, New Delhi  
Tel. No.: 24682111, 24682100

M/s. Chanderpur Works,  
Village Jorian, Radaur Road,  
Yamuna Nagar, Haryana

## Rice husk briquette fuel<sup>84</sup> Bangladesh, Commercial

<b>Crop</b>	Rice
<b>Residue</b>	Husk
<b>Process</b>	Densification
<b>Equipment</b>	Heated die screw press
<b>Main Product</b>	Briquettes

### Production Capacity

The raw material rice husk has a low bulk density (117.0 kg/m<sup>3</sup>); whereas, after densification its bulk density raised to 825.4 kg/m<sup>3</sup>. This higher bulk density ensures the easy handling, storing and transportability of this resource (Photo 3). The energy consumption by briquette machine was found to be about 175 kWh (field survey in 2006) to produce one metric ton (about 4200 kWh) of rice husk briquette fuel at producer level. Dasgupta et al. (2003) conducted a field survey in 2001 and found that the energy consumption for briquette production in producer level was quite high 250 kWh/ton. These results show that the system performances are improving day by day in production level. In laboratory research, average energy consumption was to be 116 kWh/ton only. This indicates there is a scope to find out the problem why the energy consumption in producer level is high and proper corrective measures can be undertaken to overcome this problem. Total rice husk is available for densification is estimated and 1.0462 million metric. Total production of rice husk briquette fuel was estimated as 0.942 million metric ton (Table 3) equivalent to 0.493 million ton of coal which is 2.34 times of imported coal (0.211 million ton) in the year 2002-2003 in Bangladesh (BBS 2004).

### Detailed Process Description

The waste loose biomass materials are compressed into solid fuel by densification process or briquetting process. The most widely used densification process in the developing countries is screw extrusion process, known as heated die screw press briquetting. Compaction ratio ranged from 2.5: 1 to 6:1 or even more (Reed et al. 1978 quoted in Moral 1999). "During this process the biomass is forced into intimate and substantially sliding contact with the barrel walls. This also causes frictional effects due to shearing and working of biomass. The combined effects of the friction caused at the barrel wall, the heat due to internal friction in the material and high rotational speed (~600 rpm) of the screw cause an increase in temperature in

---

<sup>84</sup> <http://cigr-ejournal.tamu.edu/submissions/volume9/Invited%20Overview%20Ahiduzzaman%20Final%20draft%2031Jan2007.pdf>

the closed system, which helps in heating the biomass. Then it is forced through the extrusion die, where the briquette with the required shape is formed.” (Grover et al. 1996).



### Job Potential

The employment generated due to production and use of densified biofuel is calculated as 3.73 man-day for producing each ton of densified biofuel (Table 4). Another study on technoeconomical aspects of biomass densification in India was conducted by Ghosh et al. (2002) and they estimated that about 4.32 man-day employment could be generated for producing each ton rice husk densified fuel which is almost similar to the results obtained in this study. Fung and Jenkins (2003) also reported that biomass energy projects could create employment for rural people. The total employment generated was estimated as 14048 employees for whole year in Bangladesh.

### Employment generated in densified biofuel flows

Raw material collection, *man-day/ton	0.75
Production process, man-day/ton	2.40
Transportation, man-day/ton	0.25
Trading, man-day/ton	0.33
Total employment, man-day/ton product	3.73
Total potential production of densified biofuel at present situation, million ton	= 0.942
Total number of employee for a year, man-year	= 14048

One man-day = 8 hr; (Field survey report, Oct-Dec 2005)

### Environmental Considerations

The data were analyzed using the GEMIS (Global Emission Model for Integrated Systems) to compare the CO<sub>2</sub> reduction with rice husk briquette fuel over firewood in Mymensingh district town (Table 5). It was found that about 1.81 kg CO<sub>2</sub> could be saved for each kg rice husk briquette fuel use over each kg of non-sustainable firewood use and about US\$ 65.65 thousand could be achieved. If it is considered as whole country this figure would be

raised to US\$ 6.84 million from the existing production of rice husk briquette in Bangladesh. Fung and Jenkins (2003) also reported that biomass energy projects could protect environment.

Table 5. Global emission CO<sub>2</sub> saving with rice husk briquette fuel options over wood fuel in Mymensingh district, Bangladesh

Option	Annual demand × 10 <sup>6</sup>	CO <sub>2</sub> equivalent × 10 <sup>6</sup> kg/year	CO <sub>2</sub> emission, kg/unit	CO <sub>2</sub> saving over 100% fuel wood system × 10 <sup>6</sup> kg/year	Return from CO <sub>2</sub> × 10 <sup>6</sup> BDT/year	Return from CO <sub>2</sub> , × 10 <sup>3</sup> US\$/year
1. 100% rice husk briquette	9.039 kg	0.954	0.105	16.42	4.33	65.65
2. 100% wood	14.244 kg	17.37	1.219	0	0	0

CO<sub>2</sub> reduction trade, US\$ 4.00/ton (Sohel 2002, p.266), 1 US\$ = 66 BDT

### Social Considerations

The time spent for collecting the rice husk briquette ranged from one sixth to one third an hour. The amount of time saving for collecting rice husk briquette over firewood was calculated as 24 mad-day/year which could save almost one month labor cost in a small restaurant (1 man-day = 8 hr works by a person or 1 labor working in a day).

### Advantages to Developing Countries

Could create employment in the rural areas

### Example of Real Life Applications

Commercial Use Rice Husk Densification Technology Bangladesh

## **Super Turbo Rice Husk Gasifier Stove Philippines, Commercial**

<b>Crop</b>	Rice
<b>Residue</b>	Rice husk
<b>Process</b>	Gasification
<b>Equipment</b>	Burner Assembly, Reactor Assembly, and Char Chamber Assembly
<b>Main Product</b>	Gas used for cooking
<b>By-Product</b>	Char

### **Technical Description of Technology**

Performance evaluation showed that the stove has a power output of 1.4 to 1.9 kw. It consumes rice husk at a rate of 1.4 to 1.7 kg per hour. Gas can be generated within 10 for 10 cm reactor and 40 minutes for 60 cm reactor from the time the fuel is ignited using a burning piece of paper. One and a half liter of water can be boiled within 6 to 9 minutes. Flame temperature measured directly at the bottom of the pot ranges from 400 to 470 C. Results of the analysis revealed that the stove has a specific gasification rate of 81.5 to 97.1 kg/hr-m<sup>2</sup> and a fire zone rate of 1.6 to 1.9 cm/min. Thermal efficiency is relatively high for this stove which ranges from 23.2 to 36.9 % especially with the use of a burner sleeve. The stove comes in four different heights of reactors – 30, 40, 50 and 60 cm. The 30 and 40 cm reactors are recommended for short time cooking, like heating water for coffee or for heating food. The 50 and 60 cm reactors are applicable for meal preparation (which include rice and simple dishes) and other home cooking activities. The stove can be used for a longer operation by disposing the char and refilling the reactor with fuel.

### **Detailed Process Description**

The stove basically is a modular type consisting of the following components: (1) Burner Assembly, (2) Reactor Assembly, and (3) Char Chamber Assembly. The burner is where combustible gas is burned to produce the required heat for cooking. It consists of a rectangular holder that support the pot in place during cooking, a burner plate that distributes the gas for even heating, air holes for the entry of the secondary air needed for the combustion of gas, and a handle for ease of removal of the burner especially when reloading fuel. The reactor assembly is where rice husk is gasified by introducing limited amount of air, just enough to cause combustion of fuel. It basically consists of an inner and an outer cylinder having a diameter of 15 and 20 cm, respectively. Between the cylinders is a rice husk ash insulation to confine heat inside the reactor. The char chamber assembly is where char is discharged. It consists of the cylindrical chamber for the storage of char having a diameter of 30 cm and a height of 15 cm, a sliding-type exit door for

ease of removal of the char, a grate that holds the rice husk fuel in place and to discharge it for disposal, and an air inlet port where the 220V-0.15 Amp fan is placed to supply the air needed by the fuel to gasify.

### **Main Products**

Gas used for cooking

### **Environmental Considerations**

The stove is convenient to use, almost similar to LPG stove. Almost no smoke is observed during operation. It can be considered an environment-friendly technology since it can address the problem of rice husk disposal and CO<sub>2</sub> emission is very minimal compared with the traditional direct combustion stoves.

### **Investment and Operating Cost**

The stove costs Rp 200,000.00 (1 US\$ = Rp 9,200) for the unit made of ordinary steel sheet while Rp250, 000.00 for the unit with parts made of stainless steel. Operating cost analysis disclosed that the stove operates at a cost of Rp663.97 per hour of cooking. A yearly savings of Rp2, 596,455.00 or Rp467, 612.14 can be derived from using the stove compared with kerosene or LPG fuel, respectively.

### **Examples of Real Life Applications**

A low-cost rice husk gas stove has recently been developed for use by households. This stove is very cheap; equivalent to only 25 percent of the production cost of its prototype model developed a couple of years ago at the CPU Appropriate Technology Center, Philippines. It has improved design but simpler, uses locally available materials, and follows simple fabrication procedure, which all together contributed to the significant reduction in the cost of the stove. The design improvement was done by a group of researchers from the PT Minang Jordanindo Approtech – Research and Development Division namely Franciscus Trya Garleman and Daniel Belonio.

### **Supplier:**

Interested individuals or organizations who would like to adopt this technology may contact The President Director, PT Minang Jordanindo Approtech, Adhi Graha Bldg., 15th Floor Suite 1502A, Jl. Gatot Subroto Kav. 56, Jakarta Selatan 12950, Indonesia. Telephone: 62-21-5262545, Fax: 62-62-215262416; and Email: [djoewito@yahoo.co.id](mailto:djoewito@yahoo.co.id) or CPU Appropriate Technology Center, College of Agriculture, Central Philippine University, Iloilo at [agriculture@cpu.edu.ph](mailto:agriculture@cpu.edu.ph).

### **Sources:**

2. <http://www.bioenergylists.org/en/beloniolowcostrhstove#attachments>



## **Rice Husk Gas Burner Philippines, Commercial**

<b>Crop</b>	Rice
<b>Residue</b>	Rice husk
<b>Process</b>	Gasification
<b>Equipment</b>	Gas burner, Dual Fuel Reactors, Char Chamber, Blower, Char Lever, Control Switch, Gas Pipe, Chimney
<b>Main Product</b>	Heat
<b>By products</b>	Carbonized Rice Husk used for composting

### **Technical Description of Technology**







The rice husk gas burner for bakery ovens is another breakthrough in the area of rice husk gasification, which is carried out by the Department of Agricultural Engineering and Environmental Management of the College of Agriculture, Central Philippine University in Iloilo City, Philippines. This technology was developed with the assistance from the group of undergraduate agricultural engineering students Lucio Larano, Daniel Belonio, Yvone Herbo, and Jeffrey Cocjin.

The rice husk gas burner for bakery ovens consists of the following components:

- (1) Dual Fuel Reactors - where rice husks are gasified during operation by burning them with limited amount of air;
- (2) Char Chamber – where burnt fuel is discharged from the reactor after gasification;

- (3) Blower – which supplies the needed amount of air for gasification;
- (4) Char Lever – which discharges burnt rice husk after gasification;
- (5) Control Switch – which intensifies or lowers the flame;
- (6) Gas Pipe – which conveys the gas generated from the reactor to the burner;
- (7) Chimney – which discharges unwanted gases; and
- (8) Gas Burner - where the gas is burned.

The fuel reactors have a diameter of 25 cm and a height of 1 meter. They are located outside the baking room for ease of operation. The burners are extended from the reactor to the oven through a pipeline. Operation is being done by dual mode so that continuous firing in the oven can be achieved.

Flammable gases, primarily of carbon monoxide and hydrogen, are produced during operation as the burning fuel moves down the reactor. The by-product after gasification is carbonized rice husk, which is a good material for composting.

The rice husk gas burner supplies energy to two 12-plate ovens simultaneously. One or two minutes is required to start firing the rice husks in the reactor. Once the rice husk are ignited, continuous operation is achieved for 30 to 40 minutes before shifting to the other reactor.

The rice husk gas burner featured in this article is owned by Mr. Gil Cordon, a baker from Jaro, Iloilo City. According to him, he uses LPG fuel for 10 minutes to start-up the oven and after that shifts to the rice husk gas burner until operation is done. He also uses LPG fuel as back up in case of power failure. Both ovens are simultaneously used when baking “Pande leche,” “Pande sal,” and other similar bread. When baking “Mamon” and “Hopia” either one or two ovens LPG back-up is used.

### **Economic Benefit**

Cost analysis showed that for an investment of P30,000.00 for the rice husk gas burner, the cost of operation is only P16.59 per hour. This amount is significantly lower as compared when using the LPG burner, which is P41.67 per hour. With a difference of P25.08 per hour in operating cost, a yearly savings of P115,562.65 can be realized when using the rice husk gas burner instead of the LPG burner. The payback period was computed at 0.25 year, equivalent to 3 months. The return on investment is 385.21% and the benefit cost ratio is 1.51.

### **Example of Real Life Applications**

**Country:** Philippines

**Level of use:** Commercial

### **Supplier**

The technology is now in commercialization stage. Interested individuals or organizations who wish to order this baking technology may contact the Project Director, Appropriate Technology Center, Department of Agricultural

Engineering and Environmental Management, College of Agriculture, Central Philippine University, Iloilo City, Philippines. Telephone number 063-33-3291971 loc 1071, email ad [atbelonio@yahoo.com](mailto:atbelonio@yahoo.com), and mobile phone 063-0916-7115222.

**Sources:**

1. [http://www.repp.org/discussiongroups/resources/gasification/Belonio/Rice\\_Husk\\_Gasifier\\_for\\_Bakery\\_Oven-Agri\\_Magazine.pdf](http://www.repp.org/discussiongroups/resources/gasification/Belonio/Rice_Husk_Gasifier_for_Bakery_Oven-Agri_Magazine.pdf)

**MXP 10 Technology  
India, Commercial**

<b>Crop</b>	Rice and Coconut
<b>Residue</b>	Husks, Shells
<b>Process</b>	Combined Heat and Power
<b>Equipment</b>	boiler
<b>Main Product</b>	Electricity and heat
<b>By-Product</b>	

**Technical Description of Technology**

This fuel fired boilers are offered in capacities upto 25 tons of steaming per hour. These boilers are offered in Shell and tube type construction, water tube construction and composite design. Thermax Solid fuel fired boilers are available designed to fire a wide range of solid fuels including agrowastes and other solid waste. These boilers are known for their ruggedness, and high efficiency, even when firing difficult fuels.

**Table 1. Technical Description of MXP 10 Technology**

Sr. No.	Details	Units	MXP-10
1.	PERFORMANCE		
1.1	Maximum output (F&A 100 °C)	kg/h	1000
1.2	Safety Valve set pressure	kg/cm <sup>2</sup>	10.54 / 17.5
1.3	Fuel		Rice Husk / Coco Shell
1.4	Thermal Efficiency (on GCV)		
	Without WPH	%	62 ± 2
*	With WPH	%	68 ± 2
1.5	Minimum calorific value	kcal/kg	3000
1.6	Maximum moisture content in fuel	%	25
	Flue gas temperature		
	At WPH outlet	°C	180
	At Boiler outlet	°C	280
1.7	Type of grate		Horizontal
1.8	Fuel condition / water quality		Refer Annexure

**Detailed Process Description**

The technology is a smoke tube; single pass boiler which can be fired on a number of fuels e.g. coal, husk, baggase and wood.

Depending on the type of fuel it has either a balanced draught or an induced draught system. The boiler consists mainly of three parts.

1. Refractory lined external furnace
2. Shell and tube exchanger pressure part.
3. Atmospheric water preheater (optional)

The furnace has a step grate or a fixed grate depending on the fuel e.g. for husk it has a step grate whereas for coal it has fixed grate. The fuel is charged through charging door to keep the fire going. The furnace is lined with refractory and insulation bricks. Furnace and steam generating section are placed in line. The draught is made available through the openings under the grate. In the case of coal firing an FD fan provides air for combustion. With the combination of FD and ID fan, balanced draught is maintained. Ash doors are provided to remove the ash from beneath the grate.

### **Main Products**

Electricity and heat

### **Environmental Considerations**

Thermax is a ISO 9000 & 14000 accredited company with its own Quality control system.

### **Investment and Operating Cost**

The output and other performance parameters of the boiler is good only if fuel has the following specification charged to the boiler. Any variation in the specifications of fuel will alter the performance parameters. The rice husk should have GCV 3100 kCal/kg and maximum moisture content 10%.

The price for supply of 1 unit MXP10 is USD 70,000.

### **Examples of Real Life Applications**

India, Philippines

### **Sources:**

1. [www.thermaxindia.com](http://www.thermaxindia.com)

**Primenergy Gasifier producing Electrical Energy & Process Steam  
U.S.A., Commercial**

<b>Crop</b>	Rice
<b>Residue</b>	Rice Straw
<b>Process</b>	Gasification
<b>Equipment</b>	Boiler, baghouse, boilers, turbine
<b>Main Product</b>	Electrical Energy and Process Steam
<b>By-Product</b>	

**Technical Description of Technology**

The technology that Primenergy employs to convert rice hulls into energy is called gasification. In the process of gasification, or the conversion of a solid into a gas, there is an insufficient amount of oxygen to completely burn the hull. The controlled atmosphere within the gasifier prohibits the formation of molten silica from the hull.

Primenergy provided a Model R-318 gasifier system, which is comprised of three gasifiers operating in parallel. The conceptual design of the process incorporated three design cases; maximum electricity production, maximum steam production and normal electrical power and concurrent process steam production. To accommodate the three design criteria, an extraction turbine with a controlled extraction lobe was selected.

Primenergy provided a Model R-318 gasifier system, which is comprised of three gasifiers operating in parallel. The conceptual design of the process incorporated three design cases; maximum electricity production, maximum steam production and normal electrical power and concurrent process steam production. To accommodate the three design criteria, an extraction turbine with a controlled extraction lobe was selected.

**Detailed Process Description**

Hot synthesis gases are generated in the gasification process and are burned in stages, for nitrogen oxide control, with final oxidation occurring within two waste heat recovery boilers. For compliance with particulate matter in vent stacks, the products of combustion exiting the boiler are filtered of fly ash in a conventional baghouse. An induced draft fan, which maintains a slight negative pressure through out the entire process, is located after the baghouse. The induced draft fan discharges into a vent stack.

High pressure, superheated, turbine quality steam from the boilers is piped to a fifteen megawatt, 13,800 volt, reconditioned turbine/generator. Located immediately beneath the turbine is a steam condenser, which operates at near full vacuum conditions. In the maximum electrical power generation

mode, all of the steam directed to the turbine is condensed and returned to the boiler via boiler feedwater pumps. The turbine selected for this application does have an extractive lobe which allows the extraction of up to 100,000 pounds per hour of medium pressure steam. The extracted steam is piped to a re-boiler, which generates utility steam for consumption in the adjoining food processing plant. By incorporating a re-boiler into the design, turbine quality feedwater is segregated from process plant quality water and avoids the possible contamination resulting from use in food processing.

The entire system, from the receipt of the rice hulls to the generation of electricity is controlled by a human machine interface located in a control room. The control room adjoins the turbine generator building and crew quarters. From the central CTR's each function of the overall process can be individually adjusted, or the overall process can operate in a fully automatic mode.

### **Main Products**

Electrical Energy and Process Steam

### **Environmental Considerations**

For compliance with particulate matter in vent stacks, the products of combustion exiting the boiler are filtered of fly ash in a conventional baghouse. An induced draft fan, which maintains a slight negative pressure through out the entire process, is located after the baghouse. The induced draft fan discharges into a vent stack.

### **Investment and Operating Cost**

All fabricated equipment was manufactured in Tulsa by Primenergy's sister company, Heater Specialists, L.L.C. and major equipment was pre-assembled prior to shipment to Arkansas. The project duration from final contact signing until initial commissioning was less that one calendar year.

### **Examples of Real Life Applications**

Rice Hulls to Electrical Energy & Process Steam  
Stuttgart, Arkansas

### **Supplier:**

Primenergy, L.L.C

P O Box 581742 Tulsa Oklahoma 74158

Phone: (918) 835-1011 Fax: (918) 835-1058

### **Sources:**

1. [http://www.primenergy.com/Projects\\_detail\\_Stuttgart.htm](http://www.primenergy.com/Projects_detail_Stuttgart.htm)

## **Carbo-V<sup>®</sup> Process<sup>85</sup>** **Germany, Commercial**

<b>Crop</b>	Solid biomass and other feed materials
<b>Residue</b>	Biomass waste
<b>Process</b>	<a href="#">Carbo-V<sup>®</sup> Process</a> , using multi-stage gasification process
<b>Equipment</b>	Multi-stage gasifier
<b>Main Product</b>	Syngas

### **Biomass**

Biomass is an infinite resource. Throughout history people have used it as food or fodder or as a fuel to generate heat. High-energy biomass containing carbon is made from CO<sub>2</sub>, water and small amounts of plant nutrients with sunlight acting as the driving force.

### **Technology**

The globally patented [Carbo-V<sup>®</sup> Process](#) lies at the heart of CHOREN technology. Using this multi-stage gasification process, it is possible to convert solid biomass and other feed materials containing carbon into combustion or synthesis gas.

### **Energy**

The gas that is produced is either directly converted into electricity and heat in gas engines or is re-synthesized using what is known as Fischer-Tropsch synthesis – a catalytic process for liquefying gas – to form a synthetic biofuel known as SunDiesel.

### **Technology**

The Carbo-V<sup>®</sup> Process is a three-stage gasification process involving the following sub-processes:

- low temperature gasification,
- high temperature gasification and
- endothermic entrained bed gasification.

During the first stage of the process, the biomass (with a water content of 15 – 20 %) is continually carbonized through partial oxidation (low temperature

---

<sup>85</sup> [http://www.choren.com/en/biomass\\_to\\_energy/carbo-v\\_technology/](http://www.choren.com/en/biomass_to_energy/carbo-v_technology/)



pyrolysis) with air or oxygen at temperatures between 400 and 500°C, i.e. it is broken down into a gas containing tar (volatile parts) and solid carbon (char).

During the second stage of the process, the gas containing tar is post-oxidized hypostoichiometrically using air and/or oxygen in a combustion chamber operating above the melting point of the fuel's ash to turn it into a hot gasification medium.

During the third stage of the process, the char is ground down into pulverized fuel and is blown into the hot gasification medium. The pulverized fuel and the gasification medium react endothermically in the gasification reactor and are converted into a raw synthesis gas. Once this has been treated in the appropriate manner, it can be used as a combustible gas for generating electricity, steam and heat or as a synthesis gas for producing SunDiesel.

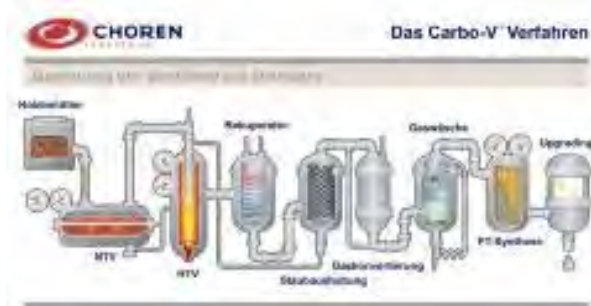

**Supplier**  
**CHOREN Industries GmbH**

Frauensteiner Strasse 59  
09599 Freiberg

Telephone: +49 (0)3731 26 62-0  
Fax: +49 (0)3731 26 62-25  
E-Mail: [info@choren.com](mailto:info@choren.com)

## Detailed Process Description

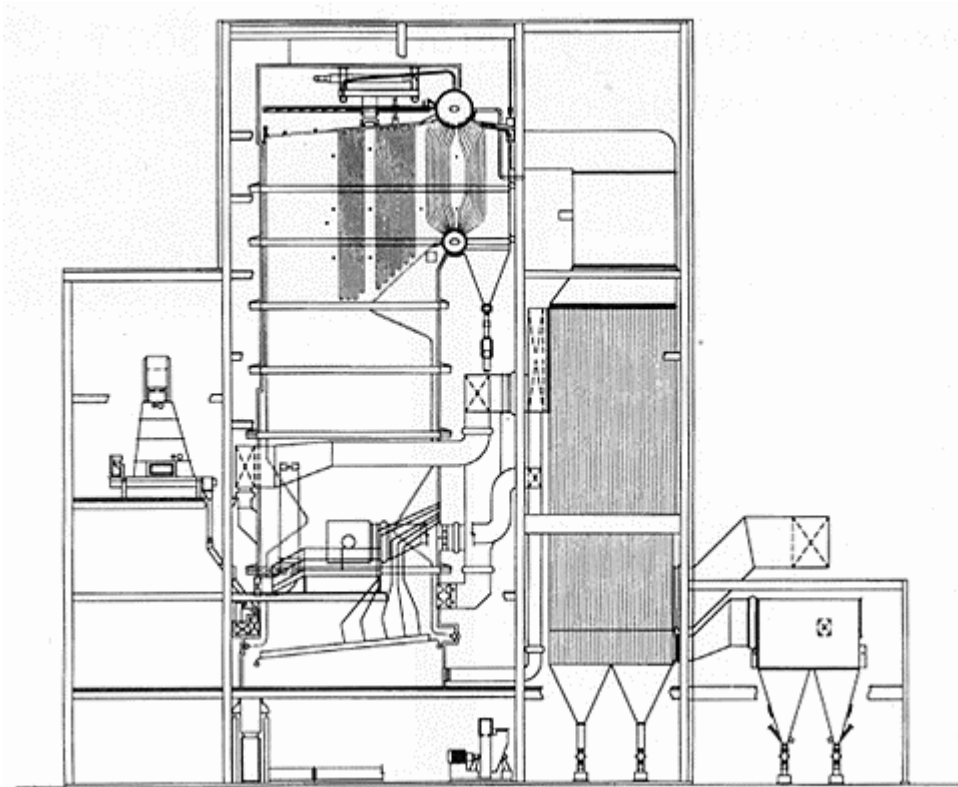

### Environmental Considerations

Company has air pollution control system

### Institutional and Regulatory Consideration or Requirements

- Performed in strict accordance with the applicable ASME Boiler and Pressure Vessel Codes, the National Board Inspection Code, and any jurisdictional requirements that may apply. McBurney currently holds the following ASME and National Board Certificates of Authorization:

**A** for the assembly of power boilers which are designed and manufactured by others.

**PP** for the design, alteration, manufacture, and erection of power piping.



## **Details of Technologies**

### **1. Waste to Energy Conversion**

#### **B. Technologies under Pilot Testing**

## Wood Biomass Electricity Generator<sup>86</sup> Japan, Pilot Demonstration

<b>Crop</b>	Wood
<b>Residue</b>	construction waste woodchips, lumber from thinning
<b>Process</b>	Direct Combustion
<b>Equipment</b>	Bioler for large electric power generator
<b>Main Product</b>	Electricity

### Production Capacity

Bioler for large electric power generator 35%	Generation efficiency above
Biomass Fuel above 70% (high content)	Electricity 50,000kW

### Detailed Process Description

Outline the facility is planned to efficiently burn woodchips with a circulating fluidized bed boiler for efficient electricity generation. Electricity may be sold to plants and electricity retailers.

### Environmental Considerations

Incinerated ash used for cement , Waste free power station

### Examples of Real Life Applications

Pilot Plant Demonstration Wood Biomass Electricity Generator<sup>87</sup> Itoigawa, Niigata Prefecture

Suppliers Operator: Summit Myogo Power Corporation



---

<sup>86</sup> Toward Expansion of Biomass Energy Introduction, Ministry of Economy, Trade and Industry, Hurihuko Ando, Nov. 15, 2006 (Plenary3.pdf)

<sup>87</sup> Toward Expansion of Biomass Energy Introduction, Ministry of Economy, Trade and Industry, Hurihuko Ando, Nov. 15, 2006 (Plenary3.pdf)

## **Modular downdraft gasifier<sup>88</sup> USA, Pilot Demonstration**

<b>Crop</b>	Coconut, sugarcane, rice, wood, palm
<b>Residue</b>	coconut shells and husks, bagasse, rice hulls, wood residues, rubber wood, and palm nutshells
<b>Process</b>	Gasification
<b>Equipment</b>	Prototype modular downdraft biomass gasifier coupled with an internal combustion engine
<b>Main Product</b>	Electricity

### **Technical Description of Technology**

The prototype modular down-draft biomass gasifier coupled with an internal combustion engine was developed by Community Power Corporation (CPC) through a cost-fund sharing with the US DOE. The units are designed to generate power in the 5kW to 25kW range by gasifying biomass fuels such as coconut shells and husks, bagasse, rice hulls, wood residues, rubber wood, and palm nut shells.

Biomass Program support through subcontracted efforts with private sector companies over the past several years, has advanced several versions of the technology to the point where they are now approaching commercialization. By adopting a standardized modular design, these 5 kW-to-5 MW systems are expected to lend themselves to high volume manufacturing techniques to bring them on a competitive level with large stand-alone plants. Using locally available biomass fuels such as wood, crop waste, animal manures, and landfill gas, small modular systems can be brought to the source of the fuel rather than incurring transportation costs to bring biomass fuels to a large centrally located plant. Small modular biomass systems also fulfill the great market potential for distributed, on-site, electric power and heat generation throughout the world.

Small modular biomass systems typically convert a solid biomass fuel into a gaseous fuel through a process called gasification. The resulting gas, comprised primarily of carbon monoxide and hydrogen, is then cleaned before use in gas turbine or internal combustion engine connected to an electrical generator. Waste heat from the turbine or engine can also be captured and directed to useful applications. Small modular systems lend themselves to such combined heat and power operations much better than large central facilities.<sup>89</sup>

---

<sup>88</sup> [http://www.eren.doe.gov/biopower/projects/ia\\_pr\\_sm\\_CO.htm](http://www.eren.doe.gov/biopower/projects/ia_pr_sm_CO.htm)

<sup>89</sup> [http://www1.eere.energy.gov/biomass/small\\_modular\\_gasification.html](http://www1.eere.energy.gov/biomass/small_modular_gasification.html)

## Small Modular Applications Biomass Gasification via Partial Oxidation (Auto Thermal)

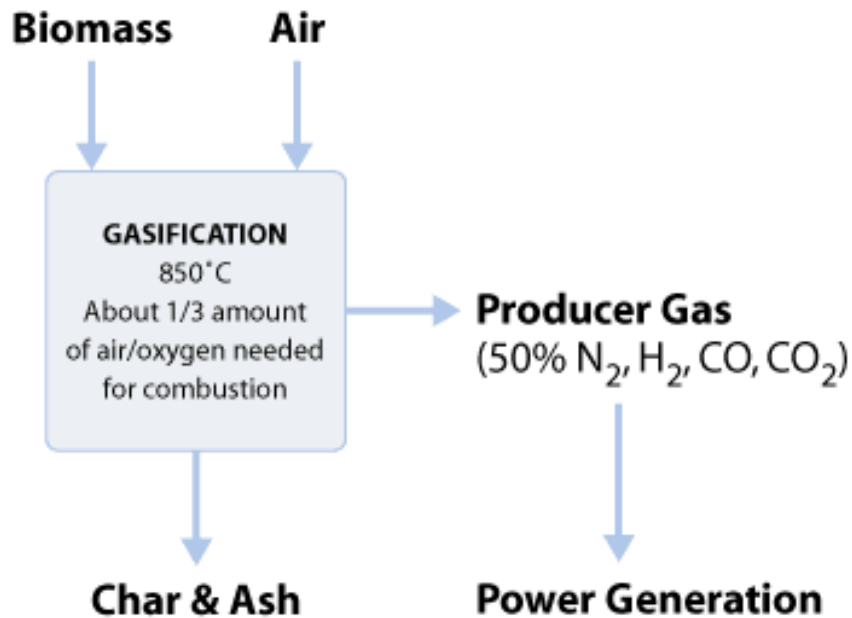

### Advantages to Developing Countries

Benefits of Small Modular Systems<sup>90</sup>

Small Modular biomass systems offer many benefits to potential customers. They have minimal environmental impact when compared to other existing technologies using coal or biomass as the fuel. On the one hand, economics can be attractive when owners connect the unit to a power grid that will buy

<sup>90</sup> [http://www1.eere.energy.gov/biomass/small\\_modular\\_gasification.html](http://www1.eere.energy.gov/biomass/small_modular_gasification.html)

unused power. On the other, small modular systems can electrify isolated areas for which the cost of connection to the grid is prohibitive. Another economic benefit may be realized if the customer has a biomass waste stream that can be converted into a source of energy rather than being an economic burden.

The flexibility to use more than one fuel also appeals to many users. Modern microprocessor control has been coupled to gasification technology to result in systems requiring minimal operator attention. And, in off-grid locations small modular biomass systems offer the potential for lights, refrigeration, heat and power to enable small cottage industries to become economically viable.

### **Examples of Real Life Applications**

In partnership with Shell International Renewables, CPC expects to initially market the systems for electrification of off-grid communities in the Philippines, Indonesia, Brazil. CPC has built a small (7 kW) prototype unit for laboratory evaluation in Colorado, and will install and evaluate field prototypes in the Philippines and United States.

### **Supplier**

Community Power Corporation (CPC)

Art Lilley [artsolar@aol.com](mailto:artsolar@aol.com)

Robb Walt [rwalt@gocpc.com](mailto:rwalt@gocpc.com)

Telephone (303) 933-3135

Fax (303) 933-1497

8110 Shaffer Parkway

Suite 120

Littleton, CO 80127



## Celunol's "wet" biomass conversion process<sup>91</sup> USA, Pilot Demonstration

<b>Crop</b>	Sugarcane, wood, etc.
<b>Residue</b>	sugarcane bagasse and wood, cellulosic biomass
<b>Process</b>	Fermentation
<b>Equipment</b>	SunOpta's patented pre-treatment equipment
<b>Main Product</b>	Ethanol

### Technical Description of Technology

Celunol is a leader in the effort to commercialize the production of **cellulosic ethanol**. The Company's technology achieves high ethanol yields from cellulosic biomass at costs competitive with conventional ethanol processes using sugar and starch crops as feedstock.

Celunol's technology enables almost complete conversion of all the sugars found in cellulosic biomass. This efficiency advantage, combined with the low input cost of cellulosic biomass, results in superior economics in the production of ethanol.

## Celunol Corp. Ethanol from Biomass Process

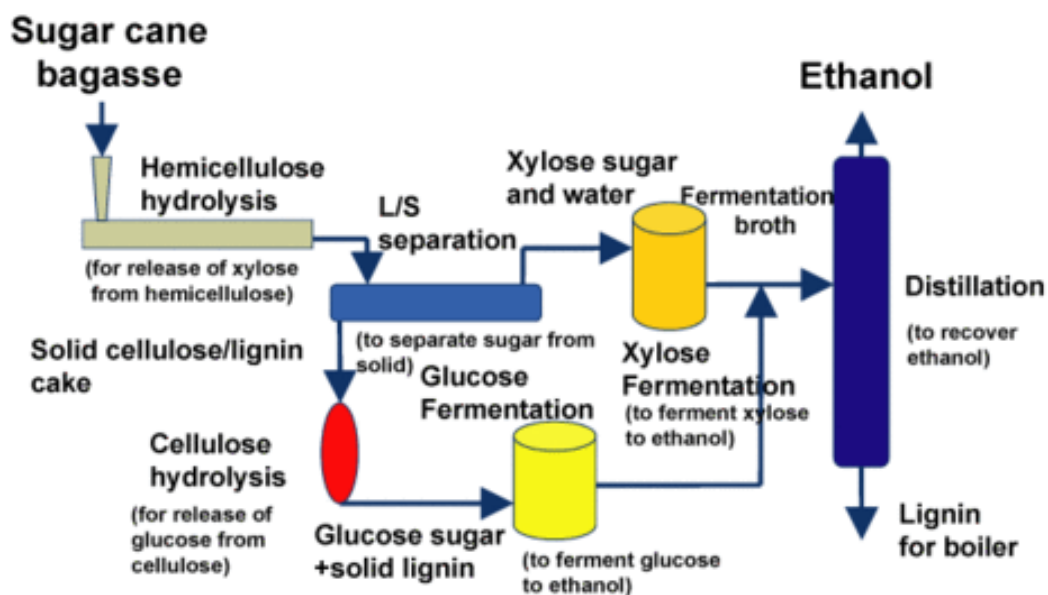

<sup>91</sup> [http://thefraserdomain.typepad.com/energy/2007/02/celunol\\_cellulose.html](http://thefraserdomain.typepad.com/energy/2007/02/celunol_cellulose.html)

Cellulose contains glucose, the same type of sugar—a six-carbon (C6) sugar—that is found in cornstarch and that can be fermented to ethanol using conventional yeasts. However, hemicellulose contains mainly non-glucose sugars—five-carbon (C5) sugars. Conventional yeasts cannot ferment most non-glucose sugars to ethanol with commercially acceptable yields.

Celunol's technology is based on the metabolic engineering of microorganisms. Its key element is a set of genetically engineered strains of *Escherichia coli* bacteria that are capable of fermenting, into ethanol, essentially all of the sugars released from many types of cellulosic biomass. This trait enables Celunol to achieve the required efficiency to make the process commercially feasible.

Celunol will use SunOpta's patented pre-treatment equipment and technology in the Jennings facility. SunOpta's pretreatment and hydrolysis technology will prepare sugar cane bagasse and possibly hard wood waste for conversion into ethanol.

### **Specific Considerations for Developing Countries**

Celunol's biomass ethanol technology offers numerous marketplace advantages:

- Feedstocks costs will be lower, and less volatile, than corn.
- Cellulosic ethanol facilities can be fueled by lignin waste streams derived from the process itself, avoiding the high and volatile price of natural gas as a boiler fuel for steam and electricity.
- Plants can be located outside traditional ethanol manufacturing areas and near end-use markets, creating a transportation cost advantage.
- Plants handling agricultural or urban wastes, pulp and paper sludge, etc. can simultaneously meet acute waste remediation needs, earn tipping fees, and yield valuable products.

### **Examples of Real Life Applications**

Celunol operates the Jennings pilot facility, on a 140-acre company-owned site in Jennings LA, designed to produce up to 50,000 gallons of ethanol per year. Celunol commenced operation of its newly expanded pilot facility in November 2006.

It is building a 1.4 million gallon demonstration facility to produce ethanol from sugarcane bagasse and wood, targeted for completion in mid 2007. This will be the first commercial scale cellulosic ethanol plant in the United States. Later, the Company is planning a commercial-scale cellulosic ethanol facility at the site.

The company has also licensed its technology to Marubeni Corp., a Japanese conglomerate, which has recently started up, the world's first commercial cellulosic ethanol facility in Osaka, Japan that employs wood waste as a feedstock. The Osaka Project utilizes wood waste as feedstock in producing

up to 1.3 million liters of cellulosic ethanol annually. A second phase, planned for completion in 2008, will increase production to 4 million liters per year.

**Supplier**

Corporate Headquarters (formerly Celunol)  
Verenium Corporation  
55 Cambridge Parkway  
Cambridge, MA 02142  
TEL 617.674.5300

## **Solid Fuel Block<sup>92</sup> Cuba, Trial**

<b>Crop</b>	Biomass
<b>Residue</b>	Biomass residues
<b>Process</b>	Densification
<b>Equipment</b>	Hand press
<b>Main Product</b>	Solid fuel blocks

### **Production Capacity**

Machinery: The machine used for the densification of the block must comply with the following requirements:

- a) Easy to operate
- b) Mechanical operation, without electrical power
- c) Productive
- d) Relatively cheap
- e) Lightweight

A new model of hand press using a hand driven screw press. This machine consists of (see fig. 4) a frame that holds a rectangular form 24 x 13 x 10 cm size. There is a lever, which holds the bottom of the form, and pushes it up after the block has been molded. A piston driven by a screw applies the pressure to the wet mass in the form to the final molding. This hand operated screw press can produce a pressure between 8-12 MPa, depending on the strength of who applies the force at the driving levers tied to the end of the screw. Field-testing performed by the authors has proven that this machine provides the necessary energy for the compaction of the SFB.

The machine has an average productivity of 150-180 blocks 1-1.5 kg each approximately per 8h journey. The cost of this machine ranges around \$US 200. It is estimated that a normal production at a workshop demands for a minimum of two machines. CIDEM is launching a new design of the machine, which over performs the former machine, mainly in compacting energy and operation.

Optionally a workshop could be equipped with a simple biomass shredder, which could eventually shred the waste biomass source in large fibers. There are many practical prototypes in the market, out of which the authors chose one, known as "hammer mill". This machine, still in a testing stage can shred the biomass fiber to a desired fiber size.

### **Production process**

The selection and screening of the biomass depends on its properties of each residue. The screened material is then shredded to fragmenting it into small pieces that could be easily bonded.

---

<sup>92</sup> SFBCuba.pdf

This process is done in shredder machines of simple operation and reasonably high productivity that are available in the market.

The most important step is the densification of the biomass. It seeks to optimize fuel disposal by increasing density. This project intends to use the existing stock of hand presses, formerly used to manufacture earth pressed blocks to shaping the SFB.

These machines attain low compacting pressure, which implies the need of a binder. Clay will be used as binder. The idea of the SFB considers both binding properties of clays. Before combustion, the clay acts as the binder that helps compacting the biomass; when the SFB is burnt, the clay present in it is thermally activated, thus becoming a reactive pozzolana that is suitable to be used for the manufacture of lime-pozzolana binders.

The resulting SFB is composed approximately of 20%-30% binder, for a moisture content (maximum) of 20%. The combustion residues account for 25-35% of the initial weight, depending on the moisture content (water). As thumb rule, the specific heat potentially generated by the active part of the fuel (biomass) is approximately half the heat produced by the same weight of coal.

The production of the SFB involves a series of aspects ranging from the preparation of raw materials, the production itself, the drying and final storage and transportation of the product. These processes will be explained below:

Biomass processing: the waste biomass used for the manufacture of the SFB has to be shredded to a fiber size not exceeding 5 mm. There are types of biomass like pulverized sawdust, which do not need shredding but normal sieving. However other types of biomass, such as roots and leaves of crops have to be pre-processed before mixing with clay.

Clay processing: The clay has to undergo a process of moisturizing, which could last some 2-4 days before it is ready for mixing. This allows breaking the clay structure and dissolving it into small grains. As the clay is kept in water for this relative long period of time, it becomes low viscosity sludge. The water / clay proportion for this sludge should be kept within 1 and 2.5 per weight. For relatively large production facilities similar to those of fired clay bricks workshops for clay processing are recommended.

Mixing of raw materials: mixing is done manually in most cases, except when a drum mixer is available. The sludge is poured into the dry biomass. Both are mixed until homogeneity is accomplished.

Pressing: before pouring the mixture in the form, a flat wooden piece must be laid on the bottom of the form. The formed block will rest on the wooden piece until it is hard enough to be removed. The wet mixture must be fed into the press. Then it must be pressed for some 15-20 seconds, until the extra water is leaked. Finally a lever pushes up the already formed block, which rests on the wooden piece. Then it is ready for handling.

Wet storage and drying: The wet block resting on the wooden piece has to be laid in flat position for initial drying. After 24 hours the block must be moved to up-right position (see fig. 5), in order to remove the wooden piece. The block must rest in this position for at least 5 days before it is moved to final storage

position. Completion of drying must be assessed directly on site. However drying must be completed before the second week after manufacture.

Transport: For transports, heaps of 160 blocks (8 x 4 x 5) of blocks should be stocked and most desirably wrapped with some tissue or paper in order to prevent disintegration. Each stock must be conveniently tied and packed for transport. The packages can be smaller, depending on the clients demand.

Final storage: The blocks can be piled up in heaps having less than 10 rows of blocks to avoid crushing. The blocks must be preferably stored in cover areas indoors, to prevent them from getting wet.

### **Job Potential**

Labor-intensive production. It is more productive and easier to operate, thus making it gender-sensible.

### **Specific Considerations for Developing Countries**

SFB is a profitable and quite viable technology, which can be implemented at very small scale with minimal resources. This represents obviously an alternative to traditional fuels, specifically in Developing Countries.

### **Environmental Considerations**

Smoke: to the technical team's surprise, the amount of smoke dramatically decreased in comparison with the firewood earlier used. As the stove is indoors, this is obviously an advantage, also seen by the workers who witness the trial.

Ash content: as expected, approximately 40% of the weight of the block was converted into ashes. However ash removal was not a problem for the continuous operation of the stove.

### **Investment and Operating Cost**

The cost of this machine ranges around \$US 200. It is estimated that a normal production at a workshop demands for a minimum of two machines.

The costs of production are described below:

1. Fixed production costs: basically include cost of indirect labor force, financial costs, transport, maintenance and other costs. As the production is very simply organized, financial costs are not considered in this analysis. The machines are paid up-front by TEDIS. Also, they use their own financial resources; therefore they do not need to go for bank loans. Fix production costs represent approximately 40% of the total production cost; most of their share (38.5%) taken by transport costs (sawdust collection with tri-wheeler cycles)

2. Variable production costs: basically include the cost of raw materials such as sawdust and clay, the cost of commodities like water and electricity, and finally the cost of direct labor force. All these costs have been set according to information provided by TEDIS. Variable costs represent 60% of the production costs. 3. Profitability margin: they usually assume it as of 20% profit. This is relatively easy to achieve, since they have been momentarily released from the production and sales taxes, as a means to stimulate production of this environmentally friendly product.

The minimal price established is \$CUP 0.09 /kg. This could be expressed in volume as \$CUP 39.06/m<sup>3</sup>. The price of a piece would then be \$CUP 0.09. The alternative product traded in the market (firewood) is sold at approximately \$CUP 58.8/m<sup>3</sup>. In this minimal profit scenario the SFB could be traded at prices approximately 34% lower than that of firewood. The break-even point for this minimal scenario is reached for 80% of sales approximately; this can be accomplished by maintaining 19 continuous working days in the month.

In a more profitable price scenario, the SFB could be traded at the same price as firewood. This would yield a price of \$CUP 0.13 apiece. The break-even point is reached after 14 days of continuous work. Table 1 summarizes the two analyzed scenarios.

Table 1: Economic analysis of SFB production in comparison with firewood.

Firewood Price x m <sup>3</sup>	SFB optimal scenario			SFB minimal scenario		
Price x m <sup>3</sup>	Price x unit	Days for BEP	Price x m <sup>3</sup>	Price x unit	Days for BEP	
58.80	58.80	0.13	14	39.06	0.09	18

### Advantages to Developing Countries

SFB is a profitable and quite viable technology, which can be implemented at very small scale with minimal resources. This represents obviously an alternative to traditional fuels, specifically in Developing Countries.

### Examples of Real Life Applications

Trial

SFB Social Kitchens  
Sta. Clara City, Cuba

### Supplier

Dr. Fernando Martirena and Engr Pedro Seijo  
CIDEM Central University of las Villas, Santa Clara, Villa Clara

[f.Martirena@ip.etecsa.cu](mailto:f.Martirena@ip.etecsa.cu)

Tel. +53 42 281539



Fig. 4: a) Hand press used for the SFB manufacture, b) Discarded CINVA-RAM press

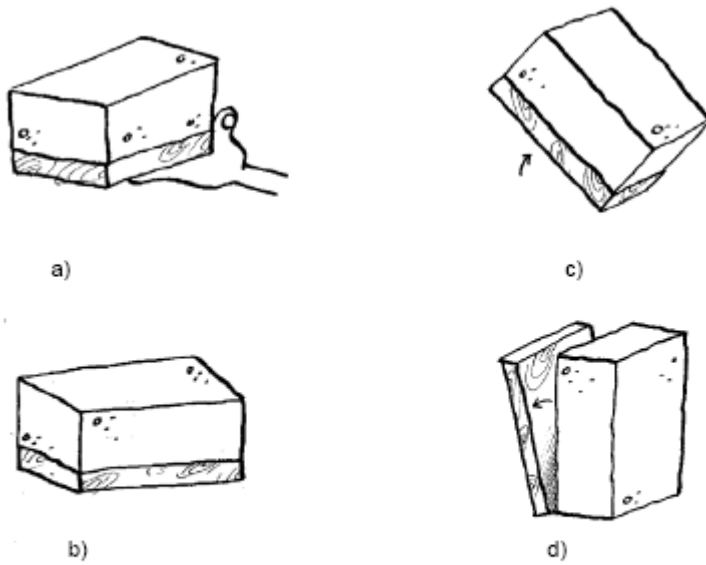

Fig. 5: Block handling after manufacture: a) The block just after pressing, b) The block should be laid for the first 24 hours, c) After 24 hrs. the block should be folded, and d) The wooden piece should be then removed





Fig. 8: SFBs packed for transportation before the trial



Fig. 9: SFBs feeding in the burning chamber

## 15kW Small Modular Biomass Systems<sup>93</sup> USA, Demonstration

<b>Crop</b>	Crops, wood
<b>Residue</b>	wood, crop waste, animal manures
<b>Process</b>	Gasification
<b>Equipment</b>	Small modular gasifier
<b>Main Product</b>	Electricity

### Production Capacity

Electric capacities of five and 15 KW have been produced. The first of these, built by Community Power Corporation, demonstrated integrated systems capability by operating in a Philippine village. This small modular technology combines a wood chip or other biomass gasifier with an engine generator to burn the gas and produce electricity. Electric capacities of five and 15 kW have been produced. At least six more demonstration locations will use Community Power combined gasifier and generator small units with installations scheduled through 2002 and 2003.

### Detailed Process Description

Users may attach the systems to existing transmission and distribution grids close to where consumers use electricity. Consumers may connect their units to the power grid on the customer's side of the electric meter.

### Specific Considerations for Developing Countries

Modular biomass systems offer many benefits to potential customers. They have little environmental impact. Economics is attractive, especially when owners connect the unit to a power grid that will buy unused power. Efficiency and the flexibility to use more than one fuel appeal to many users. Simplicity of operation means that they need no special skills to run the units. And, where no electricity now exists, biomass greatly improves quality of life with lights, refrigeration, and the comforts of home.

### Examples of Real Life Applications

Demonstration	Philippines
Demonstration	California

### Supplier

Community Power Corporation

Art Lilley [artsolar@aol.com](mailto:artsolar@aol.com)

Robb Walt [rwalt@gocpc.com](mailto:rwalt@gocpc.com)

---

<sup>93</sup> Biomass Fact sheet: Small Modular Biomass Systems, US DOE 2002

**Telephone** (303) 933-3135  
**FAX** (303) 933-1497  
8110 Shaffer Parkway  
Suite 120  
Littleton, CO 80127



Community Power Corporation/PIX12220

15 kW unit by Community Power Corporation



Rob-Valli, Community Power Corporation/PIX12220

Small modular unit connected to a power line.

## APA Gasifier<sup>94</sup> USA, Trial

<b>Crop</b>	Cotton, soybeans, wood, kenaf, sugarcane, etc.
<b>Residue</b>	cotton stalks, soybean plant residues, wood chips, kenaf, forestry residues, chicken litter, sugarcane bagasse
<b>Process</b>	Combustion
<b>Equipment</b>	Gasifier
<b>Main Product</b>	Heat

### **Production Capacity**

It can produce over 1 million Btu per hour, with 99 percent combustion efficiency

In a test in early August, using hard wood chips, the output was 1.2 million Btu from 260 pounds of chips per hour.

The equipment utilizes hydrogen and water to combust oils — soybean, cottonseed, and other heavy oils work well — and generate large amounts of heat.

### **Environmental Considerations**

Clean burning, no smoke, no soot, no odors.

Waste is minimal: from 1,400 pounds of chips, there remained only 11 pounds of very clean ash.

### **Examples of Real Life Applications**

Trials      APA Gasifier      Greenwood, Mississippi

### **Supplier**

Associated Physics of America (APA).

---

<sup>94</sup> Energy from stuff nobody wants.htm

## Solar-Biomass Hybrid Cabinet Dryer<sup>95</sup> Nepal, Pilot Demonstration

<b>Crop</b>	Wood, etc.
<b>Residue</b>	Fuel wood, wood chips, twigs, and briquettes
<b>Process</b>	Combustion
<b>Equipment</b>	Solar-biomass hybrid cabinet dryer
<b>Main Product</b>	Heat for drying

### Technical Description of Technology

The hybrid cabinet dryer (Figure 7.1) consists of an air-heating solar collector, a drying chamber, a biomass stove-heat exchanger-chimney assembly, and a chimney attached to the drying chamber at the top. During daytime, ambient air is heated by the solar collector, and the hot air is passed through trays kept inside the drying chamber where products to be dried are loaded. During poor weather conditions and at night if required, the biomass stove provides the hot air required for drying. A heat exchanger is used to avoid direct contact of flue gas with the product. Direct contact of flue gas might contaminate the product as the flue gas generally contains smoke, soot, and other harmful gases.



Figure 7.1: The solar-biomass hybrid cabinet dryer

The stove can be operated using fuels such as fuelwood, wood chips, twigs, and briquettes. As honeycomb briquette is a popular fuel in certain parts of Nepal, production of honeycomb briquette is explained in detail in this package. The products are spread in thin layers on several trays inside the drying chamber. Warm moist air from inside the drying chamber exits to the atmosphere through the chimney at the top, assisted by draft created in the chimney. Technical specifications of the solar-biomass hybrid cabinet dryer

<sup>95</sup> <http://www.retsasia.ait.ac.th/booklets/Dissemination%20Booklets-Phase%20III/Tech%20pack-Dry-low%20resl.pdf>

are given in Table 7.1. The dimensions of the drying chamber are optimized for convenient loading and unloading of the products. The drying chamber was also partitioned to minimize heat losses during handling of the product during the drying process.

### Design Details

The hybrid dryer is a modified version of the solar cabinet dryer described in Package 5. The design of the flat plate solar collector, drying chamber, and supporting stand are similar to that already presented in Package 5. The biomass stove-heat exchanger-chimney assembly is the only addition to the solar cabinet dryer. Therefore, only the design details of biomass stove-heat exchanger-chimney assembly is described here.

*Table 7.1: Technical specifications of the solar-biomass hybrid cabinet dryer*

Sl. No.	Parameter	Specifications
1.	Solar collector area	3.2 m <sup>2</sup>
2.	No. of glazing	Single
3.	Loading	Opening of doors at backside
4.	No. of doors	3
5.	No. of trays	9
6.	Air circulation	Natural
7.	Biomass stove type	Combustion type stove
8.	Fuels for stove	fuels: fuelwood, wood chips, twigs, honeycomb briquettes
9.	Stove size	0.6m x 0.3m x 0.15m
10.	Heat exchanger	Finned aluminum pipe (rectangular)
11.	Height of flue gas chimney	1.7 m
12.	Drying capacity	10 kg-fresh
13.	Construction materials	Wood, steel sections, window glass, GI sheets, aluminum sheets, MS sheets, glass wool, aluminium screws & rivets
14.	Approx. cost	NRs. 50,000*

\*1 US\$ = 74 NRs (Nepalese Rupees), March 2004

### Biomass Stove

Honeycomb charcoal-briquettes are a popular and cheap cooking fuel in certain parts of rural Nepal. The briquettes are made by mixing charcoal and clay and moulding cylindrical briquettes with a honeycomb-like cross section. A stove which can utilise the honeycomb briquettes to supply hot air for drying was therefore thought to be an attractive option for solar-biomass hybrid dryers. This stove was developed at AIT under the RETs in Asia programme within a fellowship study by RECAST, Nepal. The honeycomb briquette stove was found to provide hot air a steady temperature of 50-60°C inside the drying chamber. Only minimum supervision was needed for the stove during operation. The dried products were also of excellent quality due to indirect contact drying.

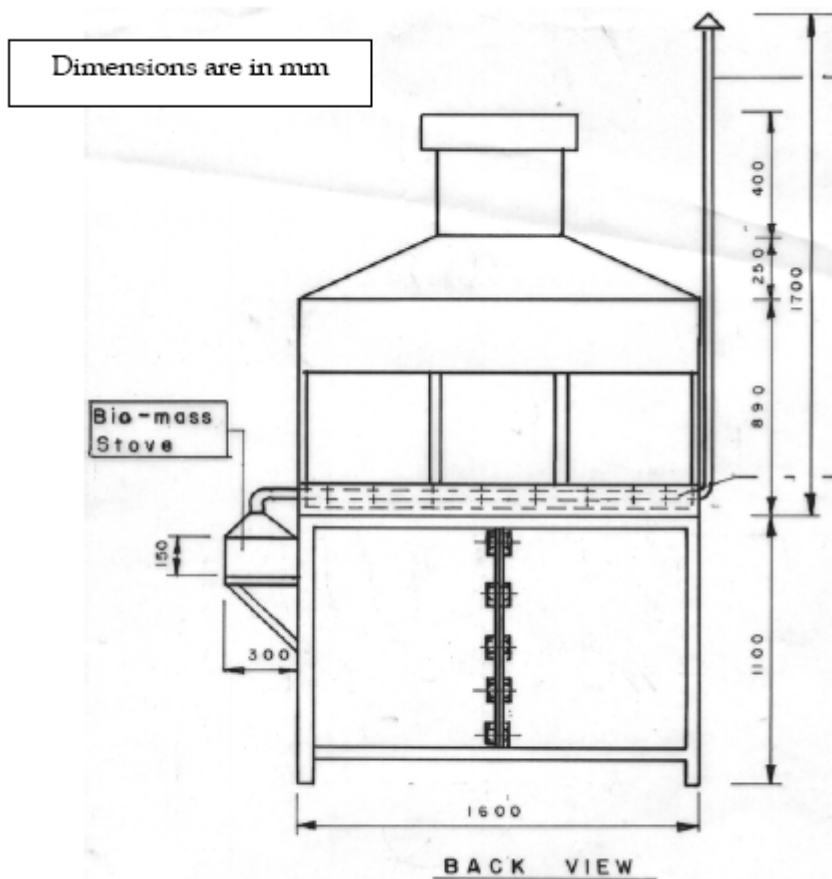

Figure 7.2: Backside view of the hybrid cabinet dryer

The stove uses cylindrical honeycomb briquettes, each of 13 cm diameter and 9 cm height, and can accommodate eight briquettes simultaneously. The stove is made of 2 mm thick mild steel sheet and is rectangular in shape. It is 30 cm x 60 cm in size, with a height of 15 cm. A grate is fixed about 5 cm above the base of the stove. Figure 7.3 illustrates the dimensional details of the stove.

The grate is made of 5mm steel rods. The distance between two rods in the grate is 6 cm. Towards the base are four rectangular openings for the entry of primary air and also for the ignition of the honeycomb briquettes. There are rectangular sliding covers in the holes, which can be adjusted to regulate the flow of primary air. The stove is covered with a hood at the top, which is connected to the heat exchanger through a connector. The hood channels the hot flue gases from the stove into the heat exchanger unit inside the drying chamber. The stove is attached to the dryer stand with mild steel angles. During start-up, honeycomb briquettes are placed over the grates, and ignited from the bottom using a flame torch. Depending on the heat requirement, one to eight honeycomb briquettes can be ignited in the stove simultaneously.

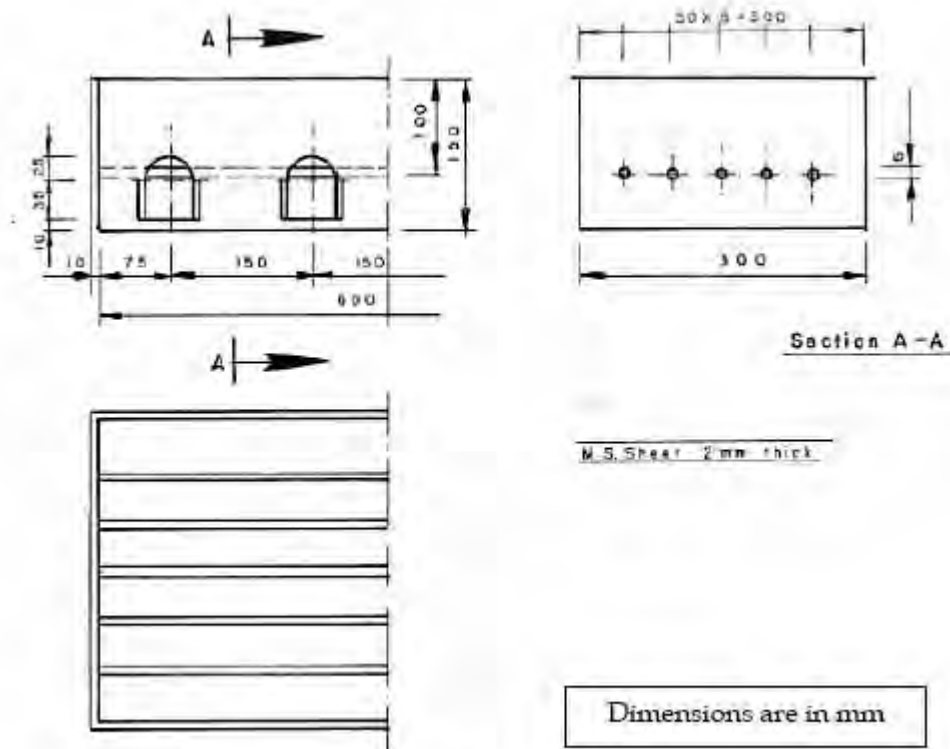

Figure 7.3: Dimensional details of the biomass stove

Although designed for honeycomb briquettes, the stove has been found to work well with other biomass fuels as well, such as fuelwood, wood chips and twigs. In locations where honeycomb briquettes are not available, this stove can thus be operated using these other fuels.

### **Heat Exchanger**

A heat exchanger transfers heat from the hot flue gas from the biomass stove to the drying air entering the drying chamber through the solar collector. The heat exchanger, made of 24 SGW aluminum sheet, is fitted above the level of the solar collector's air outlet. It is of fin and tube design, with a rectangular tube, on which aluminum fins are attached to enhance the heat transfer surface area. Hot flue gases from the biomass stove enter the heat exchanger at one side, and leave through a chimney at the other side. Process air, which gets heated up by the heat exchanger surface, flows up through the trays which hold the products to be dried. The dryer will be useful for commercial scale users for processing products such as fruits, vegetables and fish. The dryer has been tested for drying products such as radish, carrot, ginger and mushroom. As uninterrupted continuous drying is possible with this type of dryer, the quality of the dried product is better than that dried in the open sun or in the solar dryer.

### **Examples of Real Life Applications**



Research Centre for Applied Science and Technology (RECAST)<sup>96</sup>  
Tribhuvan University, Kirtipur

**Suppliers**

Research Centre for Applied Science and Technology (RECAST)  
Tribhuvan University, Kirtipur  
P.O. Box 1030  
Kathmandu, Nepal  
Tel: 977-1-330348  
Fax: 977-1-331303  
E-mail: [tu@recast.mof.com.np](mailto:tu@recast.mof.com.np)

---

<sup>96</sup> <http://sarn.ssrc.org/centres/nepal.shtml>

**Biomass Gasifier<sup>97</sup>**  
**India, Pilot Demonstration**

<b>Crop</b>	Eucalyptus, Pongamia, Suvery, Neem, Coconut Fronds, Sababul
<b>Residue</b>	Crop residues
<b>Process</b>	Gasification
<b>Equipment</b>	Gasifier with 100% producer gas engine
<b>Main Product</b>	Producer gas

**Technical Description of Technology**

250 kwe biomass gasifier at Adichunchangiri Institute of Medical Science, Balagangadharanatha Nagar, Bellur Cross, Nagamangala Taluk, Mandya District, India.

Capacity : 250 Kwe

Gross Output : 250Kwe

Net Output : 220 Kwe

Continuous output : 205 Kwe

Technology : Gasifier With 100% producer gas engine

Biomass required : 5300 Kg per day

Units generated : 3840 units per day

Biomass consumption per unit : 1.4 Kg

No of labours employed: 20 (direct employment

Indirect employment : 100 ( for collection ,transportation of biomass )

Cost of the plant : Rs 69.52 lakhs

Subsidy from MNES : Rs 37.5 lakhs

**Detailed Process Description**

The biomass gasifier is essentially a chemical reactor where various complex physical and chemical processes take place. Four distinct processes take place in a gasifier, namely drying of the fuel (woody biomass), pyrolysis, combustion and reduction. Biomass is fed into gasifier at regular intervals. The equipment is designed in such a way that it takes air in controlled quantities, resulting in partial oxidation of biomass into producer gas. One Kg of biomass gets converted into 2.5 to 3.0 Nm<sup>3</sup> of gas with a calorific value of 1000-1300 Kcal per Nm<sup>3</sup>, which would have the following composition. CO-15-20% CH<sub>4</sub>- 1-4% Co<sub>2</sub>-8-5%, N<sub>2</sub> –45-55%. The gas coming out of the gasifier is hot (200-250<sup>0</sup>C) and contains some contaminants, particulates and volatiles, which needs to be cooled and cleaned before feeding into the generators. The cooling cleaning system consists of scrubbers and associated accessories. Cold clean gas produced is fed to engine along with

---

<sup>97</sup> <http://www.kredl.kar.nic.in/Events.htm>

air. Woody biomass available in plenty around the area is collected at the rate of Rs 800 per Ton and transported to the gasifier through a skip charger.

### **Job Potential**

No of labours employed	20 (direct employment)
Indirect employment	100 (for collection, transportation of biomass)

### **Cost of the plant**

Rs 69.52 lakhs

### **Environmental Considerations<sup>98</sup>**

- It converts a traditional low quantity fuel inconvenient for use in to high quantity, combustible gaseous fuel with associated convenience
- Such conversions are relatively at high efficiencies and result in total convenience and process control
- Almost all environment pollution associated with biomass use can be eliminated
- Initial investment and also the cost of generation of energy are just about the lowest amongst all known alternatives
- Gestation period is very less and can be completed with in 3 to 6 months

### **Investment and Operating Cost**

<sup>1</sup>The cost of the gasifier works out to Rs 69.52 lakes. Considering that 70% is taken as loan and 30% is put in as equity and gasifier is run for 24 Hrs the cost of generation works out to Rs 2.46 per Kwh till the loan is paid back. After the loan is paid back the cost of generation merely works out to Rs1.92 per Kwh. If the investment is entirely made by the beneficiary, the cost of generation works out to Rs 2.68 per Kwh, Rs 2.80 per Kwh and Rs 2.92 per Kwh for the 1<sup>st</sup>, 2<sup>nd</sup> and 3<sup>rd</sup> year respectively taking 5% escalation in the fuel cost. The tariff for power for the educational institution in Karnataka is Rs 4.60 per Kwh. The Institution of Medical science is saving substantial amount after installation of the biomass gasifier. Employment of about 50.000 Kwh of energy from the date of its installation. The biomass required per Kwh is about 1.4 K.g. Total biomass consumed per day to generated about 3800 Khr is about 5300 kg. At present the energy generated is meeting the requirement of Hospital and other hostel building in the premises.

### **Examples of Real Life Applications**

Pilot Plant Demonstration Karnataka Renewable Energy Development limited's Demonstration 250 Kwe Biomass Gasifer Project.

Adichuchanagiri Institute of Medical Sciences, Balagangadharanatha Nagar, Bellur Cross, Nagamangala Taluk, Mandya District.

### **Supplier**

M/s Ankur Scientific Energy Technologies limited, Vadodara

---

<sup>98</sup> <http://kredl.kar.nic.in/BioMass.htm>



## Dry Grind Ethanol<sup>99</sup> USA, Under Construction

<b>Crop</b>	Rice
<b>Residue</b>	Straw and hull
<b>Process</b>	Fermentation
<b>Equipment</b>	Colusa Ethanol Production Facility
<b>Main Product</b>	Ethanol
<b>By-Product</b>	Silica/Sodium oxide and lignin

### Production Capacity



- Colusa facility will consume approximately 130,000 tons of waste biomass annually, producing 12.5 million gallons of ethanol and 16,800 tons of silica/sodium oxide

### Detailed Process Description

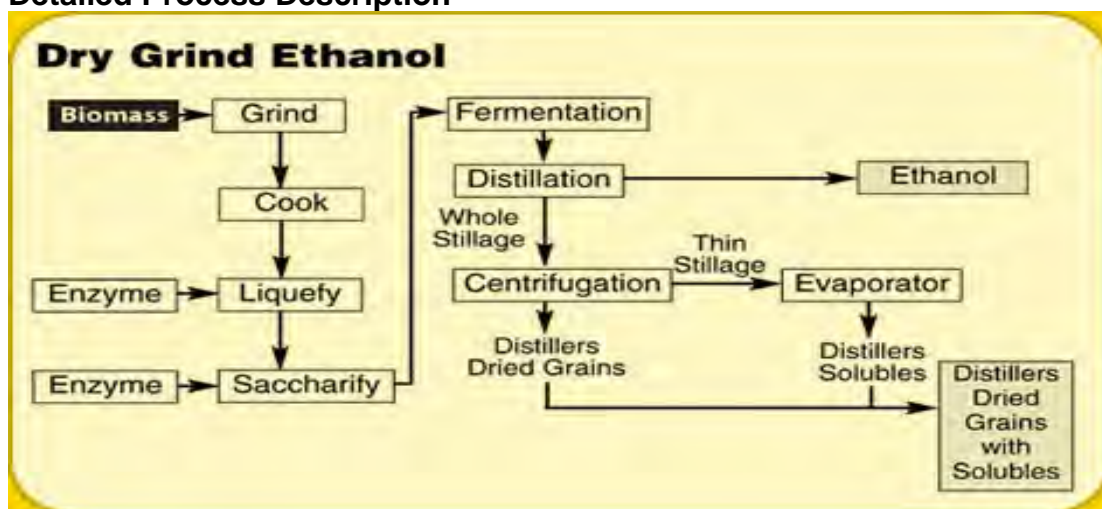

<sup>99</sup> <http://www.colusabiomass.com/about.htm>

**The Rice Straw / Hulls Technology basic process is as follows:**

- Rice straw/hulls pass through a shredder
- Shredded material passes to a steam explosion where dilute sulfuric acid is added to the material
- The material then passes to a counter current extractor containing NaOH solution. This process will place the silica and the lignin in solution
- The lignin-silicate solution passes to our ultrafiltration system where the silicate solution passes through the membrane and the lignin solution is concentrated
- The material leaving the counter-current extractor is washed and hydrolyzed, fermented and converted to fuel ethanol, or the lignin fuel separated by the ultrafiltration system is used to provide energy for the operation of the plant.

**A Block Diagram of the Colusa Biomass Energy Corporation process - Process Drawing & RO/UF Drawing**

Note: The “green” blocks are products

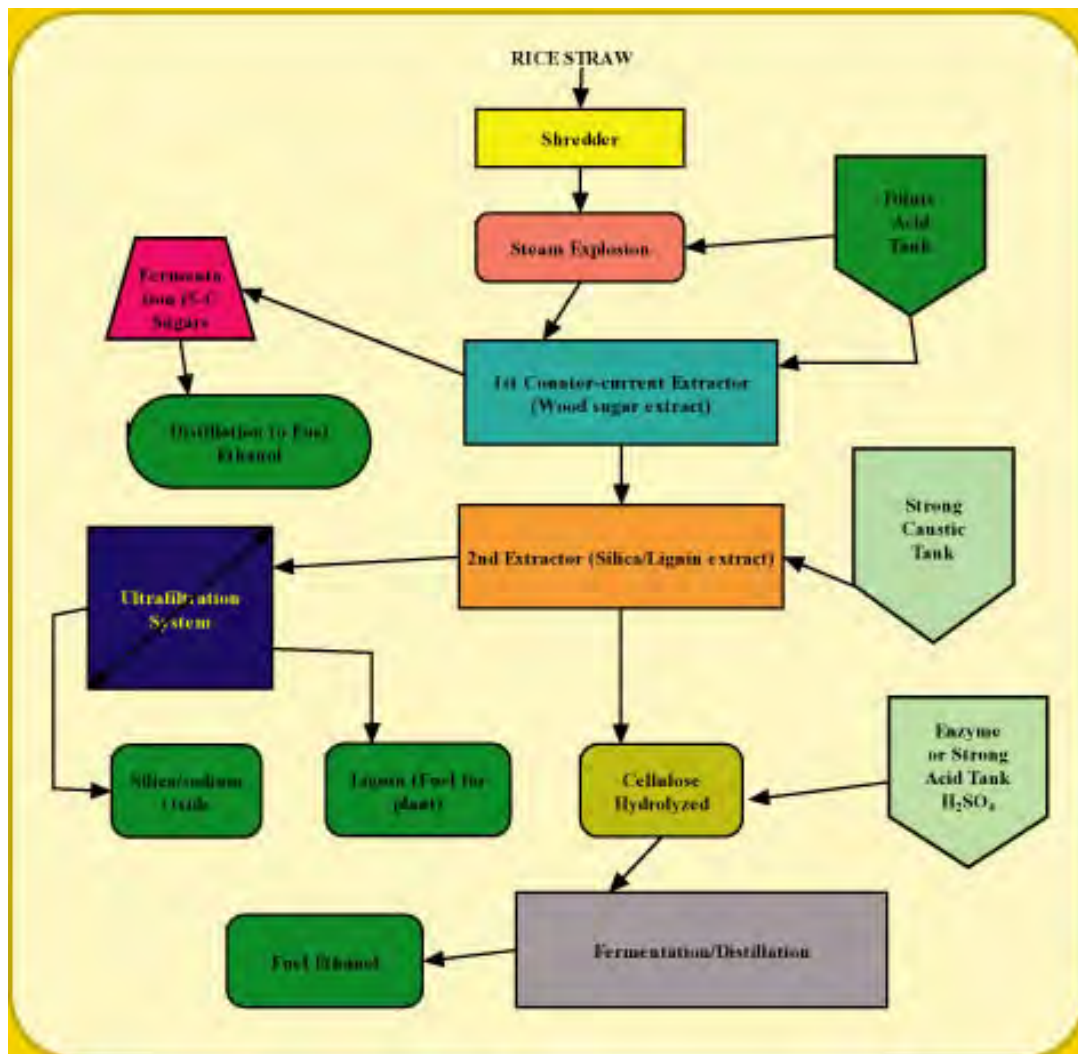

**Price**

Ethanol sells as a commodity priced (as of June '06) at \$3.36 per gallon

**Institutional and Regulatory Consideration or Requirements**

Short Abstract for US Patent 5,735,916

UNITED STATES PATENT Patent Number: 5,735,916

Lucas et al. Date of Patent: Apr. 7, 1998

PROCESS FOR PRODUCTION OF LIGNIN FUEL, ETHYL ALCOHOL,  
CELLULOSE, SILICA/SILICATES, AND CELLULOSE DERIVATIVES FROM  
PLANT BIOMASS

**References Cited**

U.S. Patent Documents

4,797,135 1/1989 Kubat et al.

5,114,541 5/1992 Bayer

5,186,722 2/1993 Cantrell et al.

**ABSTRACT**

This invention relates to a series of treatments, both physical and chemical, to plant biomass resulting in the production of ethanol, lignin, and a high protein animal feed supplement. In plants having a high silica content, a fourth product is obtained, silica/caustic oxide (silicates solution, waterglass.) Both 5-Carbon and 6-Carbon sugars are fermented to ethanol using an existing closed-loop fermentation system employing a genetically engineered thermophilic bacteria developed by Agrol, Ltd. The lignin and absolute ethanol are mixed producing a high-energy fuel.

5 Claims, No Drawings

Process For Production Of Lignin Fuel,  
Ethyl Alcohol, Cellulose,  
Silica/Silicates, And Cellulose  
Derivatives From Plant Biomass

This application is a continuation in part of application Ser. No. 08/460,493,  
filed Jul. 13, 1995, now abandoned.

**Examples of Real Life Applications**

The Colusa Biomass processing facility will be commissioned in the fourth  
quarter of 2008 Biomass to Biofuel for transportation  
1023 Main Street  
Colusa CA, 95932

**Supplier**

Colusa Energy Biomass Corporation



## Rice Husk-fuelled Cabinet Dryer<sup>100</sup> Philippines, Pilot Demonstration

<b>Crop</b>	Rice
<b>Residue</b>	Husks
<b>Process</b>	Combustion
<b>Equipment</b>	Cabinet type biomass dryer
<b>Main Product</b>	Heat for drying

### Technical Description of Technology

The dryer consists of a drying chamber and a biomass furnace-heat exchanger unit. The biomass furnace uses ricehusk as fuel, which is fed to the furnace by an automatic feeder arrangement. An air distribution system distributes hot air evenly to the several trays inside the drying chamber. The technical specifications of the dryer are given in Table 1. The design of the dryer is illustrated in Figure 1.

**Table 1. Technical Specifications of the Dryer**

Sl. No.	Parameter	Specification
1.	Drying capacity per batch	200 kg (sliced mango)
2.	Average drying air temperature	53°C
3.	Airflow rate	0.37 m <sup>3</sup> /hr
4.	Dryer Dimensions	2.90 x 1.37 x 2.00 m
5.	No. of trays	52 of 0.98x0.97 m size
6.	Total tray area	48.4 m <sup>2</sup>
7.	Fuel type, and consumption	Rice husk; 11-15 kg/hr
8.	Heat exchanger type	Shell and tube

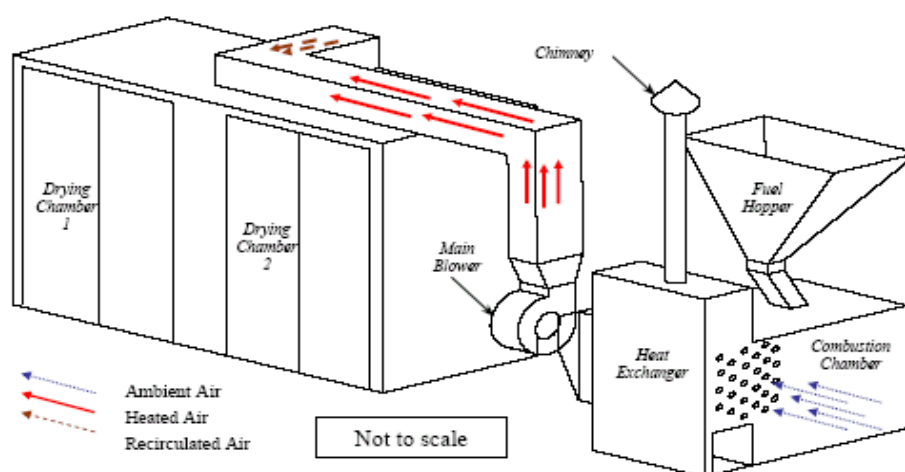

<sup>100</sup> <http://www.retsasia.ait.ac.th/booklets/Dissemination%20Booklets-Phase%20III/Tech%20pack-Dry-low%20resl.pdf>



<sup>1</sup>Figure 1. Design of the dryer

## **Detailed Process Description**

### **Drying chamber**

The drying chamber, 1.37m wide, 2m tall and 2.9m long, contains two movable tray carts having 26 trays each. It is made of galvanized iron sheets framed together by angular steel bars. The trays (of dimensions 0.98m x 0.97m) are made of polyethylene plastic mesh reinforced with aluminum bars. The total area of the drying trays can accommodate 200 kg of mango slices. The chamber also has an air distribution system, which ensures distribution of air into the entire height of the chamber. The air distribution system is composed of an axial fan (with a 0.35m dia. rotor) and a distributor duct. The distributor duct has a converging shape from top to bottom, and has thirteen concentric rings of varying diameter, arranged one above the other, at specific spacing. This system can deliver an air volume of up to 0.37 m<sup>3</sup>/sec.

### **Biomass furnace - Heat exchanger**

The rice husk-fuelled furnace is composed of five parts: the combustion chamber, heat exchanger system, fuel hopper, air inlet duct, and the chimney. The combustion chamber is made of bricks enclosed in galvanized sheet metal while the heat exchanger system is made of 27 boiler tubes arranged in a rectangular array. All other parts of the furnace are made of galvanized iron sheet. A butterfly valve controlled by a variable speed electric motor (0.5 hp) controls the feed rate of rice husk; the fuel hopper is inclined at 45° (angle of repose of rice husk) to allow free flow of rice husk into the combustion chamber. An auxiliary blower (0.5 hp) was installed in the combustion chamber to supply the primary air required for complete combustion. The primary air supply to the furnace can be controlled by adjusting the opening of the blower air inlet.

The main blower installed between the furnace and the drying chamber draws the ambient air through the furnace-heat exchanger unit, and supplies hot air to the drying chamber. An S-shaped duct is installed at the air inlet to the heat exchanger. The mouth of the duct is located away from the combustion chamber to avoid suction of ashes that may otherwise contaminate the product to be dried. The fuel hopper has a capacity of three sacks of rice hull per loading which lasts for about 3 to 4 hours of dryer operation.

### **Investment and Operating Cost**

The total cost of fabricating this dryer is about US\$1,800.

### **Example of Real Life Application**

For drying agricultural products  
Research UPLB Philippines

### **Supplier**

University of the Philippines Los Banos  
Laguna, Philippines

## Solar-Biomass Hybrid Tunnel Dryer<sup>101</sup> Thailand, Pilot Demonstration

<b>Crop</b>	Biomass
<b>Residue</b>	Waste Biomass
<b>Process</b>	Combustion
<b>Equipment</b>	Solar-Biomass Hybrid Tunnel Dryer
<b>Main Product</b>	Heat for drying

### Technical Description of Technology

This dryer is an adaptation of the tunnel dryer developed at the University of Hohenheim, Germany. The prototype described here is suitable for drying 115 kg of fruits (banana) and has been designed and fabricated at AIT. The dimensions and other design parameters of the AIT solar-biomass hybrid dryer are presented

### Size of Machine/ Production Capacity

*Table 3.1: Technical specifications of solar-biomass hybrid tunnel dryer*

Width	1.8 m
Length (collector)	4.00 m
Length (dryer)	4.25 m
Length (total)	8.25 m
Collector Area	7.2 m <sup>2</sup>
Drying area	7.65 m <sup>2</sup>
Total number of fans	5
Approx. air flow rate (single fan)	130 m <sup>3</sup> /h
Power consumption (single fan)	14 Watts
Top cover	0.2 mm thick UV-treated PE
Bottom insulation	4 cm-two layers of 25mm glass wool

### Design Details

The dryer (Figure 3.1) consists of a flat plate air-heating solar collector, integrated with a drying chamber. A common glazing, provided for both the collector and the drying chamber, forms a tunnel. A biomass stove-heat exchanger assembly is fitted at one end of the tunnel, at the collector side. The biomass stove is used as an alternate heat source for the dryer when solar energy is not available. The integrated collector-dryer unit rests on

<sup>101</sup> <http://www.retsasia.ait.ac.th/booklets/Dissemination%20Booklets-Phase%20III/Tech%20pack-Dry-low%20resl.pdf>

footings made of brick and mortar. The exact size of the brick column depends on the size of locally available bricks and may vary from place to place. Several trays are provided inside the drying chamber, on which the products are loaded in a thin layer. During daytime, the dryer is operated as a solar dryer. In cloudy weather conditions or at night, the biomass stove may be used.



*Figure 3.1: The solar-biomass hybrid tunnel dryer*

Two GI sheets are riveted together, with glass wool or any material with good thermal insulation properties and a square steel tube sandwiched in-between them, to form a module. The base of the integrated collector-dryer unit is made of such modules. Individual modules are joined together by riveting GI strips placed above and below the adjacent modules; the base is next made to fit inside the side support. The base slides through grooves in the side supports. The side support is made to hold both the base of the collector-dryer unit and its top polythene cover. The polythene cover rests on the roof supports. Each roof support has a hole drilled in the middle, and is fixed to the side support by riveting. A square pipe is attached to the module by using nuts and bolts on the two ends of the solar dryer. A steel wire that provides extra support for the roof passes through the holes made on the roof supports and is attached to the square pipes using clamps. Rubber gaskets (curved) are fixed with superglue (or Loctite) to cover all the sharp edges of the side support (top edge) that comes in contact with the polythene cover.

The polythene cover is fixed to the side support at one side along the length of the dryer. Plastic clamps (car window washers) are used to press the polythene sheet against the sealed edge of the side support. At the other side, it is rolled on a G.I. pipe of diameter 1 inch. A crank attached to the GI pipe serves to roll the polythene cover further to open the drying chamber while loading and unloading the trays. During normal operation, the polythene sheet covers the whole dryer. The zinc coating on the GI sheet of the collector base is abraded using sand paper.

This surface is then painted with matt black paint.

Table 3.2: Construction materials used for solar-biomass hybrid dryer

S.No	Item Description	Unit	Quantity
1.	Galvanised Iron (GI) sheet, #18, 4'x8'	sheet	3
2.	Galvanised Iron (GI) sheet, #28, 3'x6'	sheet	18
3.	Galvanised Iron (GI) pipe, $\phi = 1''$	meter	6
4.	Mild Steel (MS) pipe (square), 3/4''	meter	12
5.	Mild Steel (MS) pipe (square), 1.5''	meter	36
6.	Aluminium 'L' angle, 1''x1'', 3 mm thick	meter	24
7.	Aluminium split bar, 1/2''x 1mm thick	meter	24
8.	Aluminium flat bar, 1/2''	meter	6
9.	Aluminium flat bar, 1''	meter	24
10.	Aluminium wire mesh, 1mm sieve	meter	10
11.	Aluminium washers	pcs.	
12.	Aluminium rivets, 1/8''x1/2''	pcs.	1,000
13.	ACSR (Alu. Conductor, Steel Reinforced) wire, 1/4''	meter	12
14.	Super Glue	tube	4
15.	Silicone sealant, 330 ml	tube	1
16.	Glasswool, 1.22m*30.50m*2mm(blanket)	kg	22.3
17.	Electric Fan, 220 V/AC, 14 W	pcs.	5
18.	Car window/ door seal	meter	18
19.	Rubber gasket (flat)	meter	22
20.	Rubber gasket (curved)	meter	5
21.	U.V-treated polythene sheet, 3m wide, 0.2 mm thick	meter	10
22.	Misc. electrical items (wire, switches, connector etc.)		
23.	Black paint (flat) and thinner		

The dryer end is fitted with a wire net of appropriate size to prevent insects and flies from entering the drying chamber. Trays to hold the products to be dried are made from aluminum frames and stainless steel wire mesh.

A biomass stove-heat exchanger assembly is placed at the inlet of the tunnel dryer to improve the reliability of the dryer and the quality of the dried product. The heat exchanger is of cross-flow type with flue gas from the stove passing through the tubes and the ambient air flowing over the tubes before entering the dryer. Five fans, each of 14 W capacity, are used to force ambient air into the dryer, through the bank of heat exchanger tubes. The 'tubes' of the heat exchanger are connected to a biomass stove at one end and a chimney at the other. Noting that the maximum permissible temperature for fruits and vegetable drying is about 60°C, the design temperature at the outlet of the heat exchanger should not be less than this value. Eight galvanised iron (GI) pipes with outer diameter 50 mm and inner diameter 44 mm are used to provide the required heat transfer area of the heat exchanger; the tubes are arranged in a staggered manner, as shown in Figure 3.2. The tube bank is

placed inside mild steel shell of length: 1.72 m, width: 0.6 m and height: 0.16 m.

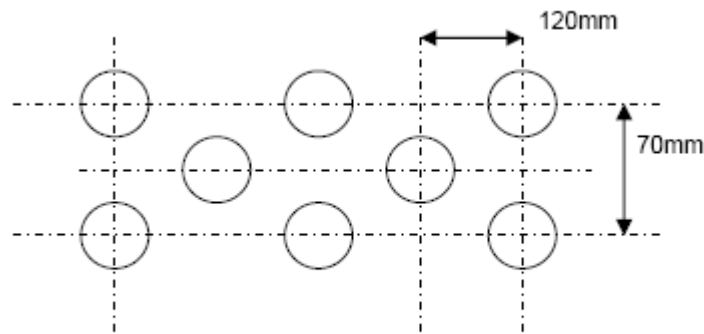

*Figure 3.2: Arrangement of tubes in the heat exchanger*

The stove is made of mild steel and has a cross-sectional area of 0.3m x 0.275m and height 0.4 m; it has a grate punched with 44 holes of diameter 1.5 cm. The inside walls of the stove are insulated with castable refractory cement. For supplying drying air at 70°C, the rate of briquette consumption is about 2.45 kg/hr. The chimney, which provides the draft needed for flue gas from the stove to flow through the heat exchanger tubes, has a cross-sectional area of 0.275m x 0.16m and height 1 m.



*Figure 3.3: Biomass stove-heat exchanger unit without insulation*

Figure 3.3 shows the biomass stove-heat exchanger unit, with the chimney attached to it. The heat exchanger is insulated with a 100 mm thick layer of rockwool and clad with 1 mm thick aluminium sheet, to reduce thermal losses. To reduce the uneven temperature distribution across the tunnel, two 12 V/6 W DC fans are used downstream of the heat exchanger to mix the hot air so that the air temperature is uniform across the tunnel, before it enters the dryer.

### **Specific Considerations for Developing Countries**

Considering the low land-holding of marginalized rural farmers in developing countries, a solar tunnel dryer has been designed for drying small quantities of agricultural products that are harvested by the farmers in the region.

### **Examples of Real Life Applications**

Asian Institute of Technology (AIT), Thailand

### **Suppliers**

Asian Institute of Technology (AIT), Thailand<sup>102</sup>

P.O. Box 4, Klong Luang, Pathumthani 12120, Thailand

Telephone: (66 2) 5160144 or (66 2) 5245000 Fax: (66 2) 516 2126

---

<sup>102</sup> [http://www.ait.ac.th/interimpage/ait\\_visitor/index.asp?screen=&res=800x600](http://www.ait.ac.th/interimpage/ait_visitor/index.asp?screen=&res=800x600)

## Biological Hydrogen Production from Sorghum by Thermophilic Bacteria Netherlands, Pilot

<b>Crop</b>	Sorghum
<b>Residue</b>	Straw and Leaves
<b>Process</b>	Biological Conversion
<b>Equipment</b>	(sodium-hydroxide) and (sulfuric acid) as catalyst, <i>Caldicellulosiruptor saccharolyticus</i> grown on glucose
<b>Main Product</b>	H <sub>2</sub> and CO <sub>2</sub>
<b>By-Product</b>	Biofuels (Ethanol and Hydrogen)

### Technical Description of Technology

Biomass is one of the renewable resources that enable a sustainable hydrogen production. The focus of this study is on the biological conversion of biomass to hydrogen. The best-known, but often not recognized, site of biological hydrogen production is in the production of biogas. Here bacteria convert organic matter to lower metabolites like organic acids, carbon dioxide and hydrogen. This hydrogen is immediately consumed by methanogenic bacteria, and methane is the final endproduct which becomes available. By decoupling hydrogen production from methane production, a complete conversion of the organic matter to hydrogen can be realised.

Hydrogen fermentations by the extreme thermophilic bacterium, *Caldicellulosiruptor saccharolyticus*, using sweet sorghum juice as carbon and energy substrate showed that it is an excellent substrate with a H<sub>2</sub> yield of 58% of the theoretical maximum at a maximal production rate of 21 mmol/L.h. Besides the sugary juice, 15 ton/ha bagasse (dry weight) is obtained from the sweet sorghum crop. The pre-treatment of bagasse for increasing biomass fermentability was optimised. After hydrolysis with commercial enzymes, 37 g glucose and 26 g xylose from 100 g bagasse could be obtained which corresponded to conversion efficiencies of 60% for cellulose and 100% for xylan. Defined media with glucose, xylose or a mixture corresponding to the sugars in the sweet sorghum bagasse hydrolysate supported growth and hydrogen production by *Caldicellulosiruptor saccharolyticus*. The theoretical production in the complete bioprocess under consideration from the 14.5 t sugars/ha could amount to 1.3 ton hydrogen/ha and to 2.1 ton when the bagasse is also converted to hydrogen.

### Detailed Process Description

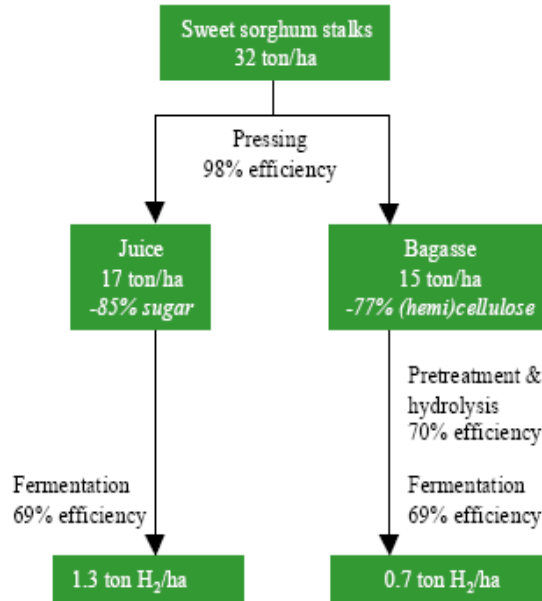

Figure 1. Flow sheet for hydrogen production from sweet sorghum  
With efficiencies which are realistic in the medium to long term.

The first step in this process is the fermentation of organic matter to hydrogen and acetic acid. This is done using thermophilic bacteria which are highly efficient and prevent growth of methanogenic bacteria. The second step is the conversion of acetic acid in the effluent of the thermophilic reactor to hydrogen. Because of unfavourable thermodynamics of this reaction, extra energy must be provided. By using photo-heterotrophic bacteria which obtain energy from light and organic matter, this drawback is overcome. The distinctive merit of the biological conversion is the efficient production of very pure hydrogen from wet biomass.

### Main Products

H<sub>2</sub> and CO<sub>2</sub>

### Environmental Considerations

Historically, syrup production was the main use of sweet sorghum, but nowadays this crop is gaining attention as a potential alternative feedstock for energy and industry, because of its high yield in biomass and, particularly, fermentable sugars. Sweet sorghum can be converted into energy carriers through either one of two pathways: biochemical and thermo-chemical. Through biochemical processes the crop sugars can be converted to biofuels (ethanol, hydrogen). Thermo-chemical processes such as combustion and gasification can be used for the conversion of the sweet sorghum bagasse (the residual cake from crop pressing) to heat and electricity. Pulp for paper, compost, and composites materials are some other products that can also be derived from sweet sorghum bagasse.

### Investment and Operating Cost

If 2.1 ton of hydrogen/ha is produced with one crop of sweet sorghum per year, the productivity would amount to 0.24 kg hydrogen/ha.h. The aim of a



bioprocess for hydrogen production from biomass is hydrogen production at small, decentralized communities. Previously [2], the goal was set at production plants with a productivity of 40 kg hydrogen/h, which would enable the supply of electricity in approximately 2000 households. Such a plant would need to be supplied by the harvest of 166 ha of sweet sorghum in Greece, and proportionally more when this crop is grown at suboptimal latitudes.

### **Examples of Real Life Applications**

South West Greece

National Technical University of Athens

Zografou Campus, GR-15700 Athens, Greece

### **Sources:**

1. [http://www.biomassandbioenergy.nl/filesdwnld/Claassen%20et%20al%20\(2004\)%20Rome%20hydrogen.pdf](http://www.biomassandbioenergy.nl/filesdwnld/Claassen%20et%20al%20(2004)%20Rome%20hydrogen.pdf)

## **Nimbkar Agricultural Research Institute (NARI) Gasifier India, Pilot**

<b>Crop</b>	Sweet Sorghum, Sugarcane
<b>Residue</b>	Leaves, Bagasse and Stalks
<b>Process</b>	Gasification
<b>Equipment</b>	Reactor, Gas Conditioning System, Biomass Feeding System, Control System, Furnace, Chimney
<b>Main Product</b>	Heat for thermal applications
<b>By products</b>	Soil Conditioners from char

### **Technical Description of Technology**

Certain critical engineering design norms of the gasification system were first developed on a laboratory-scale model and were then validated on a bench-scale model. These norms were then used to design a full-fledged commercial scale system with a thermal output of 1080 MJ h<sup>-1</sup>. This system (presently installed in the NARI campus) is seen in Fig. 1. It comprises of a reactor, a gas conditioning system, and a biomass feeding system and the instrumentation and controls. A schematic diagram of this system is shown in Fig. 2. The salient features of these components are given below.



**Figure 1. Gasifier System**

a. Reactor: This was a downdraft, throatless and open-top reactor with an internal diameter of 75 cm and an active bed height of 1.25 m. It was designed for a heavy-duty cycle of 7500 hour per year operation. High temperature resisting firebricks conforming to IS 8 grade were used for the hot face followed by cold face insulation.

b. Gas conditioning system: A completely dry dust collection system eliminated altogether the problem of wastewater. This consisted of a high temperature char/ash coarse settler and a high efficiency cyclone separator. A specifically designed high temperature resisting induced-draft fan ensured that the entire system is under negative pressure so that in the event of leaks, outside air got sucked into the system, but the combustible gas did not leak out. Thus, this design is very environment-friendly. The char-ash from the coarse settler and the cyclone was collected in barrels and emptied in an ash pit once every forty-five minutes. This char-ash which typically has a gross calorific value of 18.9 MJ kg<sup>-1</sup> can be briquetted to form an excellent fuel, or can be used as a soil conditioner.

c. Biomass feeding system: This consisted of a scraper drag-out conveyor and a hopper to convey the biomass fuel from the storage pile to the reactor. The conveyor was completely enclosed.

d. Instrumentation and Control System: A Programmable Logic Controller (PLC)-based control system seen in Fig. 2 was designed to take automatic corrective actions under certain critical conditions. Thus, the biomass feeding and ash removal rates were fully controlled by this system. Besides, it also helped the operator in trouble-shooting by monitoring temperatures at various critical points in the gasification system. Automatic burner sequence controllers were provided for ignition of the producer gas.



**Figure 2. Programmable Logic Controller (PLC)-based control System**

## Detailed Process Description

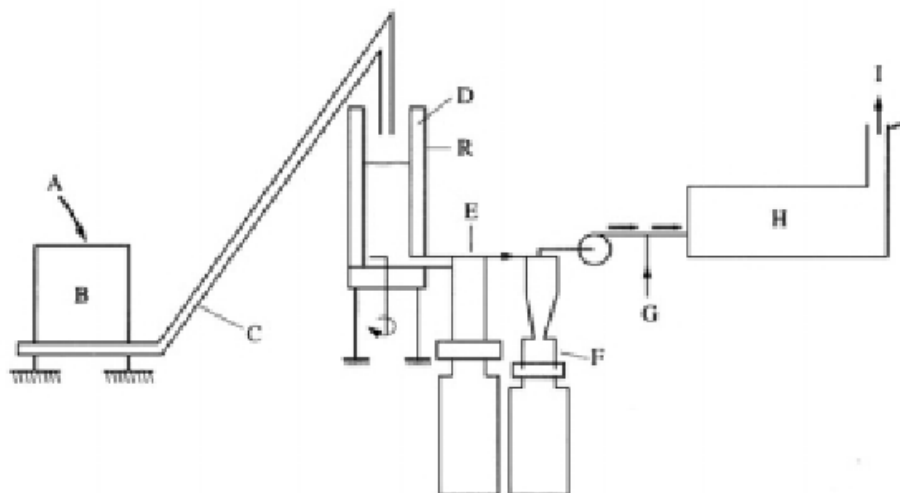

**Figure 3. Schematic Diagram of Gasifier**

**A. Biomass from storage piles B. Hopper C. Conveyor D. Refractory E. Char Collector F. Cyclone G. Air H. Furnace I. Chimney J. Reactor**

The gasification system was extremely simple to operate. A cold start took about ten-fifteen minutes whereas a hot start was effected in less than five minutes. Only two operators per shift of eight hours were required to operate the system, including the fuel and ash handling operations.

## Advantages to Developing Countries

The gasifier was operated on both sugarcane leaves and bagasse either interchangeably or mixed in any proportion. The output was in the range of 288-1080 MJ h<sup>-1</sup> (thermal). In the present system, the gas temperature was maintained above the condensation temperature of the tar compounds right up to the burner. Thus, there was no condensation of tars, and so, this problem did not arise due to the use of a hot gas cleaning system. The blower impeller was also free from any deposits/scales. Thus, a major source of downtime in most gasification systems, namely that of choking of pipes/equipment with tars and particulate matter, appeared to be successfully tackled by employing a hot gas cleaning system.

## Example of Real Life Applications

Nimbkar Agricultural Research Institute (NARI).  
P.O. Box 44, PHALTAN-415523, Maharashtra, INDIA

## Sources:

1. <http://nariphaltan.virtualave.net/Gasifier.pdf>

## Transpired Collector Solar-Biomass Hybrid Cabinet Dryer<sup>103</sup> Philippines, Pilot Demonstration

<b>Crop</b>	Biomass
<b>Residue</b>	Biomass residue
<b>Process</b>	Gasification
<b>Equipment</b>	hybrid solar-biomass dryer
<b>Main Product</b>	Heat for drying

### Technical Description of Technology

UPSL/UPD developed a hybrid solar-biomass dryer that incorporated several innovative features. This drying system is distinct from the traditional solar dryer designs due to use of an Unglazed Transpired Solar Collector (UTC) for harnessing solar energy. The major use envisaged for this dryer was fish drying. The dryer, which can accommodate 10 kg of fish, consists of a drying chamber, a solar collector and a biomass stove/furnace.

### Design details

The hybrid dryer was designed to operate with the UTC and the biomass gasifier stove as the primary heat sources. This ensures continuous operation of the hybrid dryer even during periods of inadequate solar radiation, as at night. For the UTC operation, the solar radiation incident on the UTC heats the perforated absorber plate. Convection transfers the heat absorbed by the collector to the ambient air being drawn into the UTC plenum through the perforations. The heated air from the collector is ducted into the heat exchanger shell. The heated air inside the drying chamber passes through the drying trays while picking up the moisture from the products being dried. The moist air exits the drying chamber through the exhaust vent located on top of the drying chamber. The continuous flow of air in the drying chamber has been ascertained through the use of the vent mounted exhaust fan. Varying the size of the opening of the exhaust vent through the use of dampers regulates the airflow rate.

*Table 10.1: Technical specifications of the transpired collector hybrid cabinet dryer*

Sl. No.	Parameter	Specification
1.	Capacity per batch	10 kg (~40 fishes)
2.	Drying air temperature	50°C (maximum)
3.	Air velocity	0.03 m/s
4.	Dimensions	0.914 m×1.829 m×0.465 m
5.	No. of trays	3
6.	Total tray area	2.9 m <sup>2</sup>
7.	Solar collector type	Unglazed transpired solar collector (UTC)
8.	Solar collector area	2.33 m <sup>2</sup> (1.83 m×1.22 m)
9.	UTC air gap (plenum)	10 cm
10.	UTC perforation pitch	14.5 cm
11.	UTC porosity	1.1%
12.	Biomass stove type	Natural draft cross-flow gasifier stove
13.	Fuel for stove	Fuelwood

<sup>103</sup> <http://www.retsasia.ait.ac.th/booklets/Dissemination%20Booklets-Phase%20III/Tech%20pack-Dry-low%20resl.pdf>

### **Solar collector**

Unglazed transpired solar collectors have lower cost, and higher reliability compared to flat plate collectors. As the name indicates, UTC has no glazing, and consists of a low porosity perforated absorber plate fixed close to a back wall, which can be a vertical wall of the drying chamber. A circulating fan in the air collection duct draws ambient air near the front surface of the absorber plate through the perforations. Air is heated while passing through the perforations in the hot absorber plate. Although UTCs have slightly higher radiation losses, these are offset by other advantages such as low reflection losses, low cost, simple construction, and easy maintenance. The working principle of UTC is illustrated in Figure 10.1.

Figure 10.2 shows a photograph of the collector used in the dryer. The collector is made of two parts: an aluminium absorber plate, and a galvanized iron (GI) box which houses the absorber. The perforated absorber is constructed using plain aluminum sheet of 20 SGW (0.81mm) thickness, measuring 2.44m (length) x 1.27m (width). The absorber plate has circular perforations, with a hole diameter of 1.6mm and a pitch of 14.5mm. The box is constructed using 20 SWG (0.91mm) GI sheet, measuring 2.44m (length) x 1.27m (width), and a plenum depth of 0.10m. The total aperture area of the collector is 6.20m<sup>2</sup>.

The collector is tilted at a slope of 45° to maximize the amount of solar radiation incident on the absorber plate. The collector is connected to the drying chamber using mild steel ducts. During operation, ambient air is drawn in by a blower through the perforations in the absorber plate. The hot air is delivered to the drying chamber through the connecting ducts. The design parameters of the unglazed transpired solar collector are given in Table 10.2.

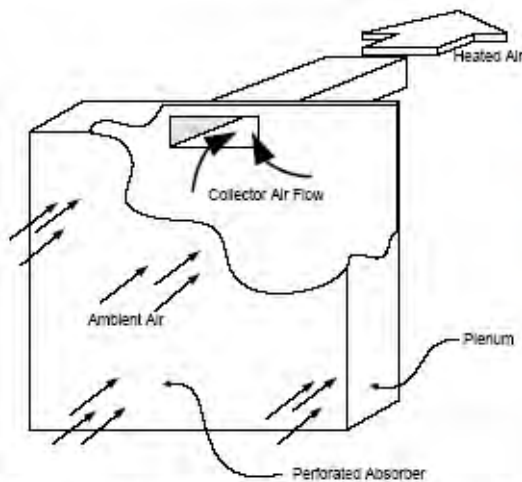

Figure 10.1: Working principle of an Unglazed Transpired Solar Collector (UTC)



Figure 10.2: The Unglazed Transpired Solar Collector used in the Dryer

Table 10.2: Technical specifications of the UTC

SI. No.	Parameter	Specifications
1.	Collector material	Galvanised Iron (GI)
2.	Collector area	6.20 m <sup>2</sup> (2.44 m x 1.27 m)
3.	Perforation pitch	14.5 mm
4.	Perforation diameter	1.6 mm
5.	Porosity	1.1%
6.	Plenum depth	0.1 m
7.	Blower capacity	140 W

### **Drying chamber**

The drying chamber contains three shelves and air ducts, which introduce hot air from the solar collector and the biomass furnace into the chamber at several levels. A chimney installed at the top of the chamber facilitates air circulation through the chamber.



Figure 10.3: Drying chamber of the hybrid dryer

### **Biomass stove**

The biomass gasifier stove design was adapted from a cross-draft gasifier stove developed by AIT. The exhaust gas from the burner is channeled through a shell and tube type heat exchanger, which heats up the drying air. The optimal values of design parameters such as the plenum depth of the solar collector, airflow rate, perforation pitch, and collector area were established through experiments. All the materials used for the fabrication of the dryer were readily available in the local



market. Simple design ensured that local technicians and craftsmen could carry out the fabrication.



*Figure 10.4: The transpired collector solar-biomass hybrid cabinet dryer*

Using only the solar collector, the dryer could dry fish from about 75% (wet basis) initial moisture content to 15% final moisture content in about two and a half days. However, by using both solar heat and biomass stove, the required 15% final moisture content could be achieved in 17 hours.

### **Examples of Real Life Applications**

Pilot Demo                                      UPB/UPLB Philippines

### **Supplier/Contact**

Philippine Project Team

Prof. Rowaldo R. del Mundo

Head of Solar Laboratory, University of the Philippines Diliman (UPD)

Quezon City, Philippines 1101.

Tel: +632 434 3661; Fax: +632 4343660; E-mail: [rmundo@info.com.ph](mailto:rmundo@info.com.ph)

Dr. Arnold R. Elepaño

Associate Professor, College of Engineering and Agro-Industrial Technology

Institute of Agricultural Engineering, Division of Agricultural & Bio-Process Engineering

University of the Philippines Los Baños (UPLB), College, Laguna 4031, Philippines.

Tel: +63 49 536 2650; Fax: +63 49 536 3291; Email: [retsas@laguna.net](mailto:retsas@laguna.net)



## **Details of Technologies**

### **1. Waste to Energy Conversion**

#### **C. Technologies under Laboratory Testing**

## **High Temperature Air Combustion (HiTAC) technology U.S.A., Research**

<b>Crop</b>	Rice and Corn
<b>Residue</b>	Rice Straw and Husk, Corn Cobs
<b>Process</b>	Gasification
<b>Equipment</b>	quartz tube, tube furnace, stainless cylindrical cage, heating coils
<b>Main Product</b>	Steam, Syngas for electricity

### **By-Product**

### **Technical Description of Technology**

The development of High Temperature Air Combustion (HiTAC) technology led to first applications of highly preheated gasifying agent in laboratory scale that now appears very promising for practical implementation as ultra High Temperature Air/Steam Gasification (HiTAG) technology. Results from gasification experiments with preheated gasifying agent showed the capability of tar reduction and increase in HHV of the synthesis gas at higher gasification temperatures. The preheated gasifying agent delivers enthalpy that is a substitute to energy released by oxidation or partial oxidation of the feedstock in normal gasification systems, thus more chemical energy contained in the feedstock can be turned into heating value of the yield. In this case, the enthalpy of the feed gas drives the endothermic reactions (water gas and Boudouard reactions) that are the main source of hydrogen and carbon monoxide production in the product stream. This also increases the efficiency of the process. Preheated gasifying agent must be at high enough temperatures that would satisfy the demand for endothermic water gas reaction. Because of the limitations in heat exchangers production, such process has not been economically justified before, and thus not developed. Gasification process usually takes place at high temperatures from 800 to 1800oC. However, with the recent developments in high temperature air combustion and gasification technology. It is now possible to have air preheats much in excess of 1100oC. Temperature, gasification agent and biomass waste composition affects the quality of product gas composition and tars produced during gasification. The objective of this study is to examine the effects of gasification agent temperature and composition on the product syngas composition with special focus on the amounts of hydrogen produced using various biomass wastes.

## Detailed Process Description

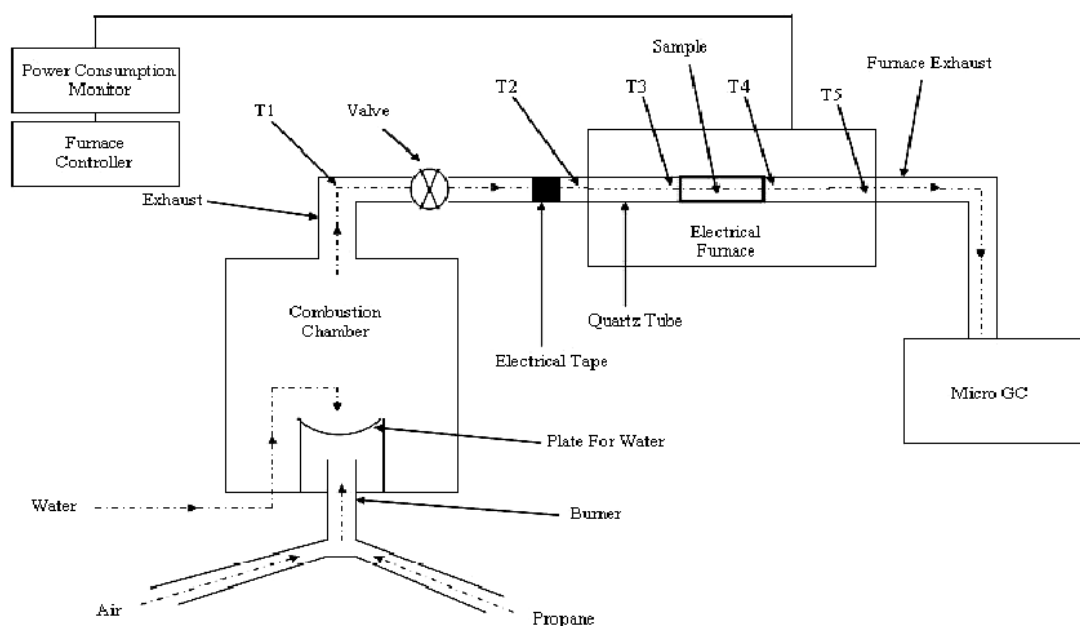

**Figure 1. Schematic Diagram of High Temperature Gasification (HiTAG) Facility.**

The experimental fixed bed reactor gasification facility utilizes High Temperature Air/Steam Gasification (HiTAG) technology. The facility provides highly preheated gasifying agent to the reactor at any desired temperature. To increase the amount of steam in the reactor, additional water is added to the flame using a syringe pump. The total steam flow rate in the gasifying agent comprises of steam from the combustion of hydrocarbon fuel and the amount of injected (evaporated) water. The product syngas composition was measured using a micro gas chromatograph. Gasification section consisted of gasification fuel sample placed in a quartz tube that this tube was placed in an electrically heated tube furnace. The fuel samples were placed in a stainless steel cylindrical cage so that the high temperature gases can flow pass when placed in the quartz tube. The heating coils in the furnace heats up the quartz tube to maintain a desired temperature in the gasification section. The temperature of the furnace is controlled by an additional control unit. During the gasification process, gas temperatures were measured at the inlet and outlet and inside the furnace, and also in front and just behind the biomass fuel sample. Micro-GC allowed setting of all the functions and parameters using the software.

### Main Products

Steam and Syngas

## Environmental Considerations

According to international policies of CO<sub>2</sub> reduction, the positive environmental issue of biomass utilization is the zero net production of greenhouse gases. In contrast to fossil fuels biomass does not bring any new carbon into the environment so the total carbon balance is equilibrated. Gasification of non-woody biomass wastes has been conducted experimentally to examine the effect of gasification agent temperature and waste composition on the product gas composition with special focus on the amounts of hydrogen produced. The temperature and chemical composition of gasification agent was controlled using a premixed burner and water injection into the high temperature zone of the flame. Increase in gasifying agent temperature enhanced the volume and heating value of the syngas using pure steam or air/steam as the gasifying agent. Pure steam gasification produced more H<sub>2</sub>, CO and CH<sub>4</sub> as compared to air/steam case, in particular at low gasification temperatures. The gasification characteristic of all the biomass wastes examined was similar and depends on the biomass fuel composition. Gasification at higher temperatures resulted in more hydrogen yield in the product stream. The quality of steam used had an important effect on the syngas composition. Much higher yields of hydrogen can be achieved using ultra high temperature steam with negligible amounts of tars and hydrocarbons in the syngas.

## Investment and Operating Cost

Rice husk, rice straw and corncob were examined here and the results compared with cellulose that represents a baseline case. For each sample moisture content was determined gravimetrically by oven drying method. Lower heating value (LHV) at a constant volume was measured using adiabatic oxygen bomb calorimeter. A chemical analysis laboratory using standard analytical method determined proximate and ultimate analyses.

## Examples of Real Life Applications

Department of Mechanical Technology, Rajabhat Phranakhon University, Bangkok, Thailand,

Department of Mechanical Engineering, University of Maryland, College Park, MD 20742, USA

Ecotopia Science Institute, Nagoya University, Nagoya, Japan.

Industry Academic Cooperation Foundation, Kyungnam University, Masan, Korea

## Sources:

3. <http://www.energy-based.nrct.go.th/Article/Ts-3%20high%20temperature%20steam%20and%20air%20gasification%20of%20non-woody%20biomass%20wastes.pdf>

**Forest Products Research and Development Institute (FPRDI) Biomass  
Pyrolyzer  
Philippines, Research**

<b>Crop</b>	Rice, Coconut, Corn, Coffee
<b>Residue</b>	rice hull, shells of pili, peanut and coconut, corn cobs, coffee bean hull and wood chips
<b>Process</b>	Pyrolysis
<b>Equipment</b>	biomass pyrolyzer
<b>Main Product</b>	Combustible gas and carbon producing power
<b>By-Product</b>	

**Technical Description of Technology**

Small-scale biomass pyrolyzer for farm irrigation produces combustible gas and carbon from agro-forest wastes such as rice hull, shells of pili, peanut and coconut, corn cobs, coffee bean hull and wood chips. The gas can be used to fuel an internal combustion to drive irrigation pumps. The system is capable of pumping about 30,000 gallons of water per hour compared to the traditional diesel engine pump's 12,000 gallons per hour output. It can supply the water requirement of a 9.3-hectare farm in eight hours.

To simulate actual application, the unit was operated continuously to supply process steam for a small pulp and paper plant with an average output of 1.0 ton per 8-hour operation. Optimum operating conditions were obtained using dry sawdust at 14% moisture content as fuel, with temperature of 920°C.

**Justification/Profitability Indicators**

Equipment Cost : P 180,000  
NPV : P 277,168  
BCR : 1.8

**Main Products**

Combustible gas and carbon producing power

**Environmental Considerations**

An energy audit on the system showed that the unit had an overall thermal efficiency of 70% with pollution-free exhaust even when low grade fuels were used.

## Examples of Real Life Applications



### Sources:

1. [http://setup.dost.gov.ph/c\\_commerce.php?view=225](http://setup.dost.gov.ph/c_commerce.php?view=225)

## Advanced Gasification-Combustion (AGC) Technology USA, Research

<b>Crop</b>	Corn, Wheat, Sorghum, Rice, Cotton, and Barley.
<b>Residue</b>	Straw and Stalks
<b>Process</b>	Gasification
<b>Equipment</b>	Gasification Reactor, CO <sub>2</sub> Release Reactor, Oxygen Transfer Reactor
<b>Main Product</b>	Pure H <sub>2</sub> , CO <sub>2</sub> , SO <sub>2</sub> to Recovery and Disposal, Hot Vitiated Air to Turbine
<b>By-Product</b>	Electricity

### Technical Description of Technology

In the AGC technology, coal/opportunity fuels and air are simultaneously converted into separate streams of (1) pure hydrogen that can be utilized in fuel cells, (2) sequestration-ready CO<sub>2</sub>, and (3) high temperature/pressure oxygen-depleted air to produce electricity in a gas turbine. The process produces near-zero emissions and, based on preliminary modeling work in the first quarter of this program, has an estimated process efficiency of approximately 67% based on electrical and H<sub>2</sub> energy outputs relative to the higher heating value of coal.

### Detailed Process Description

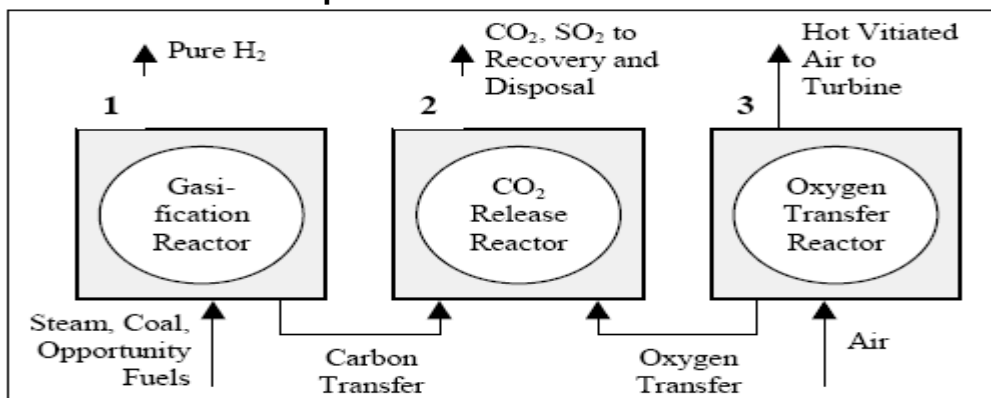

Figure 1. Conceptual Design of AGC Technology

Figure 1 shows the conceptual design of the AGC technology where three reactors are used. In Reactor 1, coal and opportunity fuels (5-10% by heat input) are gasified by steam in the presence of a CO<sub>2</sub>-absorbing bed material. As CO<sub>2</sub> is scavenged, CO is also depleted from the gas phase due to the water shift reaction. Consequently, mainly H<sub>2</sub> is released from Reactor 1. Only part of the solid fuels fed to Reactor 1 is gasified to produce hydrogen. The remaining char and bed material are transferred to Reactor 2 where the carbon is oxidized to supply the thermal energy necessary to regenerate the

CO<sub>2</sub>-absorbing bed material and release CO<sub>2</sub> as shown in Figure 1. Oxygen-transfer bed material is moved from Reactor 3 to Reactor 2 to provide the oxygen necessary to oxidize the char in Reactor 2, in turn raising the bed temperature for decomposition and release of CO<sub>2</sub>. Air is supplied to Reactor 3 to regenerate the oxygen-transfer bed material. Coming out of Reactor 3, the hot oxygen-depleted air passes to a gas turbine to generate electricity and the hot bed materials return to Reactor 2. Ash and some bed material will be removed from the system periodically to reduce the amount of ash in the reactor and to replenish the bed materials with fresh compounds.

### **Main Products**

Pure H<sub>2</sub>, CO<sub>2</sub>, SO<sub>2</sub> to Recovery and Disposal, Hot Vitiated Air to Turbine

### **Environmental Considerations**

For most of the field and seed crops, the residues are directly incorporated back into the soil; plowed under or tilled back into the soil. Soil incorporation is important because it aids soil stabilization, reduces soil erosion from wind or water, and helps fertilization by replacing nutrients and organic matter. Small amounts are used for grazing or feeding of livestock. The sustainable amount of residues that can be removed depends on a variety of site-specific considerations, including soil characteristics, topography, crop rotation, tillage practices, etc. It has been estimated that 30-60% of the residues could be recovered. For this evaluation, it is roughly assumed that 50% of the residues are recoverable.

Rice straw is a special case where currently much of the straw is disposed of directly in the field through open burning. Open in-field burning has been preferred because it potentially reduces plant disease (stem rot), eradicates insects and pests, maintains some soil nutrients and quality, and helps crop yield. However, due to air quality concerns, allowance of the open burning of rice straw is being phased out in California, for example, thus producing a need for alternative rice straw handling practices. It is estimated that 60% of the rice straw is available.

### **Investment and Operating Cost**

It is estimated that crop residues can be collected at a cost of 25-50 \$/BDT (bone-dry ton), depending on various factors including collection procedure, bale size, fertilizer make-up, farmer incentive, etc.

### **Examples of Real Life Applications**

General Electric Energy and Environmental Research Corporation  
Irvine, CA 92618

Southern Illinois University at Carbondale  
T. R. Miles Technical Consultants, Inc.

### **Sources:**

1. [http://www.fischer-tropsch.org/DOE/DOE\\_reports/40974/FC26-00NT40974-1/40974%2007-01-01.pdf](http://www.fischer-tropsch.org/DOE/DOE_reports/40974/FC26-00NT40974-1/40974%2007-01-01.pdf)



## Wood wool cement board (WWCB) Cement bonded boards<sup>104</sup> Philippines, Research

<b>Crop</b>	Sugarcane, coconut, tobacco, corn, wood
<b>Residue</b>	sugarcane bagasse, coconut coir fiber, tobacco, and corn stalks, wood residue
<b>Process</b>	Densification
<b>Equipment</b>	Press
<b>Main Product</b>	Panel board

### Technical Description of Technology

FRDI developed a new panel product called cement-bonded board (CBB) from agroforest wastes and residues. CBB panel is made of either shredded wood, flakes/splinters/particles of wood or agricultural wastes and residues like sugarcane bagasse, coconut coir fiber, tobacco, and corn stalks. It is bonded with ordinary portland cement and some mineral additives and cold-pressed under low pressure and ambient temperature. CBB has been found to possess the essential physical properties adapted to the country's climate. Wood wool cement board (WWCB) and other panel products out of the abovementioned agroforest wastes are found to be weather- and fire-proof. They are resistant to fungal and termite attacks and possess excellent thermal and acoustic insulating properties. These boards are ideal for low-cost housing projects where they can replace expensive construction materials like bricks, hollow blocks, tiles and plywood.



<sup>104</sup> <http://www.uplb.edu.ph/community/fprdi/commtech/cbb.htm>

**Example of Real Life Applications**

Department of Science and Technology  
Forest Products Research and Development Institute  
College, Laguna, Philippines

**Supplier**

Department of Science and Technology  
Forest Products Research and Development Institute  
College, Laguna, Philippines  
Tel. Nos. (6349) 536 -3630; 536-2586; 536-2360; 536-2377  
Fax. No. (6349) 536-3630  
e-mail : fprdi@laguna.net

## Furnace-Type Lumber Dryer<sup>105</sup> Philippines, Research

<b>Crop</b>	Biomass
<b>Residue</b>	Biomass waste
<b>Process</b>	Combustion
<b>Equipment</b>	Furnace-type lumber dryer
<b>Main Product</b>	Heat for drying

### Technical Description of Technology

The furnace-type lumber dryer is a cheap yet efficient lumber dryer that can meet the standards set by both local and foreign markets for Philippine-made wood products. The FTLD is easy to install and can be made from locally available materials; easy to operate; utilizes biomass as heat source; dries wood materials to a level acceptable to both local and foreign markets, has drying efficiency comparable with that of conventional steam-heated dryer. Some of the spin-offs from the FTLD are the bamboo, grass and handicraft dryers.



### Suppliers

DOST Central Office

Address: DOST Bldg. Gen. Santos Ave., Bicutan, Taguig, Metro Manila, 1631  
Philippines

Telephone Nos: (632) 837-20-71 to 82

Fax: (632) 837-8937

---

<sup>105</sup> <http://www.uplb.edu.ph/community/fprdi/commtech/rhac.htm>

## Honeycomb Briquettes<sup>106</sup> Nepal, Research

<b>Crop</b>	All types of biomass materials
<b>Residue</b>	Biomass waste
<b>Process</b>	Densification
<b>Equipment</b>	Charring drum
<b>Main Product</b>	Honeycomb briquettes

### Technical Description of Technology

The technique involves the following three stages:

- (i) Partial carbonization of biomass residues,
- (ii) Mixing of char with a binder, and
- (iii) Briquette moulding and drying.

The procedure requires a charring drum in which the biomass is charred. The char obtained by the carbonization of biomass residues is crushed and mixed with a binder such as clay, and then briquetted in a briquette mould into cylindrical honeycomb briquettes. The details of the technique are presented below.

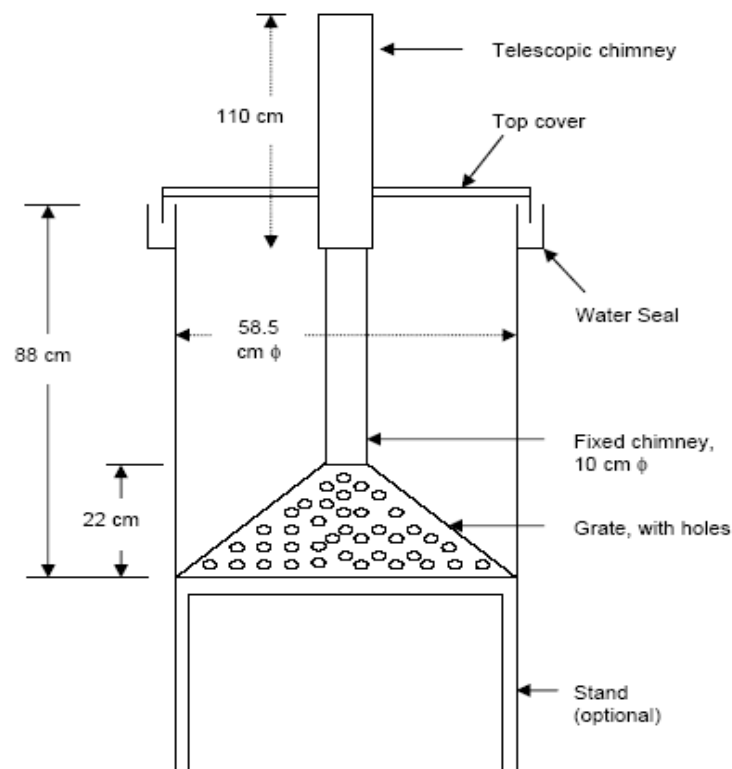
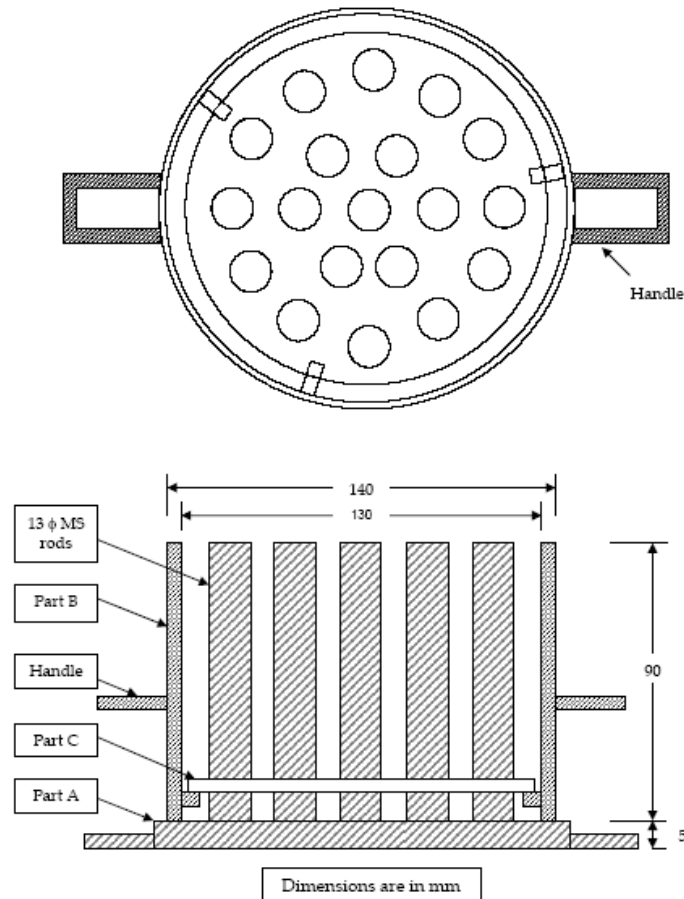

Figure 7.4: The charring drum

<sup>106</sup> <http://www.retsasia.ait.ac.th/booklets/Dissemination%20Booklets-Phase%20III/Tech%20pack-Dry-low%20resl.pdf>

(i) Charring Drum. The charring drum can be fabricated using empty crude oil drum of 200-litre capacity. It is fitted with a conical shaped grate with fixed chimney and a top cover and water seal arrangements as shown in Figure 7.4.

(ii) Briquette Mould. The briquette mould is made up of mild steel. It consists of three parts: the bottom plate with nineteen protruding rods each 13 mm in diameter, outer cylindrical cover to fit the bottom plate, and a perforated plate to slide down along the rods into the cylinder, as shown in Figure 7.5.



[Note: A, B and C are separate parts of the mould]

Figure 7.5: Briquette mould

(iii) Charring Procedure. All types of biomass materials can be used in a charring drum for char production. If the biomass material is too loose (e.g.: pine needles, leaves, etc.), then they can be made into small bundles of 7-10 cm diameter and up to 60 cm length. Depending upon the type of biomass, about 40-100 kg of biomass can be carbonized in the charring drum to get a yield of 25-35% char over a period of 2 - 3 hours. First, the conical grate with fixed chimney is placed inside the drum and the telescopic chimney is placed over the fixed chimney as shown in Figure 7.4. One to two kilograms of dried leaves or twigs are spread uniformly over the conical grate and ignited. Once the ignition starts, biomass material is added to it in small portions so that the material inside the drum does not burn fully or too fast, and turn into ash.

Once the drum is full and top layer is partially carbonized, the telescopic chimney is removed and the drum is covered with its cover. Water is filled in the channel so that there is no leakage of air through the water sealing arrangement.

At this stage, smoke will be released through the hole provided at the centre of the cover. When the smoke ceases to come out, the hole should be blocked by the stopper. There should be no leakage of air during cooling. The drum is allowed to cool for 2 to 3 hours before it is opened for removing the char and starting the next batch. The biomass residues should be sized properly and sun-dried to only 10-15% moisture (wet base). Depending upon the type of biomass and its moisture content, char yields of 25-35% can be obtained. During charring, a large amount of volatiles are released so it is advisable to use these drums in open spaces. Further these drums can be easily transported to the areas of biomass availability. To get maximum production, the drum should be filled up to the top and only then the lid should be placed and water seal made. To avoid rusting of the drum, it is coated with coal tar while it is hot. Due to heat, the applied tar will crack leaving behind an impervious coating of carbon on the surface, which prevents the drum from rusting.

(iv) Briquette-making. The biomass char is crushed to fine powder form to get a particle size of not more than 0.8 mm. It is then mixed with 20-30% by weight of bentonite clay or local potters' clay which acts as a binder. Molasses or cooked starch may also be used as binder. The amount of water that is sufficient can be judged by taking the mixture in hand and pressing it firmly to form a ball. If a ball cannot be formed, extra water may be added to the mixture. The mixture thus obtained is covered with wet gunny bags, and is left for 24 hours for maturing.



Figure 7.6: Briquette-making using the mould

For making beehive shaped briquette from the char-clay mixture, different parts of the briquette mould set are placed one over the other in a sequence, as shown in Figure 7.5. First, the base plate, part 'A' is placed on a levelled surface. The outer part 'B' is placed on it. Finally, the plate with 19 holes, 'C' is placed over the bottom plate 'A', in such a way that it rests on pins supports as shown in the figure.



Figure 7.7: Drying of molded honeycomb briquettes

The mould set is filled with the mixture and after filling up to the brim, the top layer is levelled with a flat wooden piece. Now, holding the handles of both part A and part B, the mould is turned upside down on to a firm ground. The mould is removed and the briquette is allowed to dry in the sun for 2-3 days. These beehive or honeycomb briquettes are superior to other briquette shapes as the honeycomb structure allows better contact between the fuel and air during combustion.

### **Examples of Real Life Applications**

Research Centre for Applied Science and Technology (RECAST)<sup>107</sup>  
Tribhuvan University, Kirtipur

### **Supplier**

Research Centre for Applied Science and Technology (RECAST)  
Tribhuvan University, Kirtipur  
P.O. Box 1030  
Kathmandu, Nepal  
Tel: 977-1-330348  
Fax: 977-1-331303  
E-mail: [tu@recast.mof.com.np](mailto:tu@recast.mof.com.np)

---

<sup>107</sup> <http://sarn.ssrc.org/centres/nepal.shtml>

**FD-50 Solar-Biomass Hybrid Cabinet Dryer<sup>108</sup>**  
**Philippines, Research**

<b>Crop</b>	Coconut
<b>Residue</b>	Coconut shell or charcoal
<b>Process</b>	Combustion
<b>Equipment</b>	Cabinet type solar-biomass hybrid dryer
<b>Main Product</b>	Heat for drying

Cabinet type solar-biomass hybrid dryer using a solar collector during daytime operation, and a biomass stove for operation during cloudy weather conditions and at night.

Sl. No.	Parameter	Specification
1.	Capacity per batch	50 kg sliced fruit
2.	Drying time	18 hrs
3.	Drying air temperature	up to 60°C
4.	Airflow rate	0.05 m <sup>3</sup> /hr
5.	Dimensions	1.4×1.0×2.69 m
6.	No. of trays	30 of 0.98×0.5 m
7.	Solar collector area	2.12×0.9 m
8.	Collector air gap	0.05 m
9.	Fuel type	Coconut shell/charcoal
10.	Fuel consumption	2.0 kg/hr

**Detailed Process Description:**

This cabinet type dryer, referred to as Model FD-50, has three main components: solar collector, drying chamber, and biomass stove. The air-heating solar collector is of flat plate type, and has an absorber area of 1.9 m<sup>2</sup>.

The drying chamber of has 30 aluminum wire net trays to hold the products. An exhaust fan powered by a 45 W electric motor fixed in the chimney of the drying chamber forces ambient air to pass through the collector. The air thus forced gets heated while passing through the collector, and rises up through the several trays on which the products being dried are spread in thin layers. The biomass gasifier stove assists drying whenever solar radiation is insufficient.

---

<sup>108</sup> <http://www.serdp.ait.ac.th/reric/>



## Solar Collector

The solar collector has a matt black-coated GI absorber sheet, and a single Plexiglas cover positioned about 5 cm above the absorber. The metal walls of the collector box are insulated with 8 cm thick glass wool to reduce heat losses. The solar collector supplies the hot air required for dryer operation during the day time. The dimensional details of the collector are presented in Figure 8.2. The solar collector is attached to the backside of the drying chamber at an angle of 15° to the horizontal. Hot air from the collector enters the drying chamber at the bottom and rises through the several trays which hold the products to be dried. A fan inside the drying chamber assists the flow of hot air from the collector up through the trays.

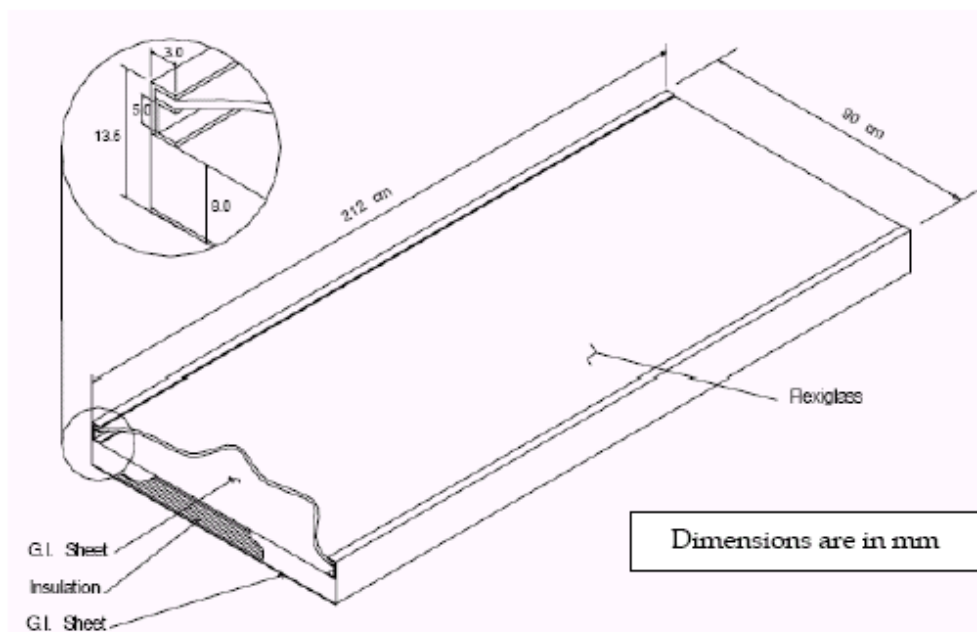

## Gasifier Stove

The design of the gasifier stove was adapted from the gasifier stoves developed at the Asian Institute of Technology. Details of this stove are given in Package 2. It consumes about 2 kg of coconut shell or wood charcoal per hour and is capable of providing drying temperatures up to 60°C.

Performance tests showed that a batch of 50 kg of sliced pineapple with an initial moisture content of 85% (wet basis) could be dried to a final moisture content of 20% in about 18 hours at a drying temperature of 60°C. The total cost of the complete drying system (including the solar collector and gasifier stove) was about US\$1,120 as of Feb 2002.

## Application

Drying fruits, fish and herbal products

## Examples of Real Life Applications

Research Level Solar-Biomass Hybrid Cabinet Dryer  
FD50Solar Laboratory at University of Philippines Diliman (UPSL/UPD)  
and the Institute of Agricultural Engineering - University of Philippines Los  
Banos (IAE/UPLB)



## **Fluidized Bed Combustor for Steam Generation<sup>109</sup> Philippines, Research**

<b>Crop</b>	Wood
<b>Residue</b>	Dry sawdust
<b>Process</b>	Combustion
<b>Equipment</b>	Fluidized Bed Combustor
<b>Main Product</b>	Steam

### **Technical Description of Technology**

Fluidized Bed Combustor for Steam Generation Optimum operating conditions are obtained using dry sawdust at 14% moisture content as fuel, with temperature of 920C. An energy audit on the system showed that the FBC unit had an overall thermal efficiency of 70% with pollution-free exhaust even when low-grade fuels were used.

### **Fluidized Bed Combustor for Steam Generation<sup>110</sup>**

The system consists of a fluidized-bed reactor, variable speed screw feeder, fluidizing air blower, induced draft fan and dry cyclone particle separator integrated with a 15Hp, 100psi, 2-pass, horizontal return tube boiler.

Fuel feeding the unit was easily controlled, and on automatic mode approached the convenience of fossil oil fuel. Initial tests showed that the boiler coupled to the system reached 85% of its rated capacity.

### **Potential Industry User**

Medium scale steam-using wood processing plants.

### **Justification/Profitability Indicators**

Cost of Equipment : P 1.2 M  
NPV : P 577,500  
Savings in cost of diesel fuel : P 393,400/yr  
(Partial Budget Analysis)

---

<sup>109</sup> <http://www.uplb.edu.ph/community/fprdi/commtech/fbc.htm>

<sup>110</sup> <http://setup.dost.gov.ph/commerce.php?view=213>



### **Examples of Real Life Applications**

Forest Products Research and Development Institute  
Narra St., UP Los Baños, Laguna

### **Supplier**

Forest Products Research and Development Institute (FPRDI)

Address: Narra St., UP Los Baños, Laguna

Phone: (049) 5363630; 5362586; 5362360; 5362377

Fax: (049) 5363630; 5362586

Web Site: <http://www.uplb.edu.ph/community/fprdi>

E-mail: [fprdi@laguna.net](mailto:fprdi@laguna.net)

Executive Director: Dr. Florence P. Soriano

## Small-Scale Biomass Pyrolyzer for Farm Irrigation<sup>111</sup> Philippines, Research

<b>Crop</b>	Rice, pili, peanut, coconut, corn, coffee, wood
<b>Residue</b>	Rice hull, shells of pili, peanut and coconut, corncobs, coffee bean hull and wood chips
<b>Process</b>	Pyrolysis
<b>Equipment</b>	Biomass Pyrolyzer
<b>Main Product</b>	Gas

### Technical Description of Technology

The Biomass Pyrolyzer produces combustible gas and carbon from agro-forest wastes such as rice hull, shells of pili, peanut and coconut, corncobs, coffee bean hull and wood chips. The gas can be used to fuel an internal combustion engine to drive irrigation pumps. The system is capable of pumping about 30,000 gallons of water per hour compared to the traditional diesel engine pump's 12,000 gallons per hour output. It can supply the water requirement of a 9.3-hectare farm in eight hours.



### Example of Real Life Application

Research UPLB

### Supplier

University of the Philippines Los Banos, Philippines

---

<sup>111</sup> <http://www.uplb.edu.ph/community/fprdi/commtech/farm.htm>

## PhilRice Flatbed Dryer<sup>112</sup> Philippines, Research

<b>Crop</b>	Rice, corn, coffee,
<b>Residue</b>	Rice Hull and other farm by-products such as corncobs, or coffee hulls
<b>Process</b>	Combustion
<b>Equipment</b>	Furnace
<b>Main Product</b>	Heat

### Technical Description of Technology

PhilRice adapted the Vietnamese design by using hollow blocks for bin. The design of furnace was replaced with an inclined step grate type instead of the original vibrating ash grate. Later, the furnace was made of adobe replacing the firebricks in the original design.

The dryer can complete drying from wet or dripping wet to 13-14% MC; dried output can be used for seed purposes with accurate control of temperature at 43°C. It consumes 35 kg of rice hull per hour but it can also use other farm by-products such as corncobs, or coffee hulls as fuel for heating drying air.



### Operation and Maintenance Requirements

Simple to operate and needs minimal maintenance

### Specific Considerations for Developing Countries

It is simple and easy to fabricate. It also has multi-crop capability for other grains such as corn, coffee, legumes, and other crops (banana and cassava)

---

<sup>112</sup> <http://www.philrice.gov.ph/machinery/flatbed.htm>

chips) aside from palay and allows drying during unfavorable weather conditions, i.e., at night and during typhoons.

### **Examples of Real Life Applications**

Drying fruits and palay

Philippine Rice Research Institute

### **Suppliers**

#### **Philippine Rice Research Institute**

Maligaya, Science City of Muñoz

Nueva Ecija

Philippines

3119

[prri@philrice.gov.ph](mailto:prri@philrice.gov.ph)

(+63) (44) 456-0277

(+63) (44) 456-0441

SMS: (+63)(920) 9111-398



## BTL (biomass-to-liquid) conversion technology USA, Research

<b>Crop</b>	Corn, sugarcane, wood, etc.
<b>Residue</b>	Feedstocks from renewable waste materials including wood waste, bagasse and corn stover, organic waste, manure, sewage digester gas or landfill gas. <sup>113</sup>
<b>Process</b>	Syntec Process
<b>Equipment</b>	Gasifier
<b>Main Product</b>	Ethanols and Bio Alcohols

### Technical Description of Technology:

The Syntec Process has the potential to revolutionize the ethanol industry with higher ethanol yields and lower production costs per ton of feedstock than any other ethanol production path in use today. Furthermore, it is anticipated that the Syntec Process will enable the conventional ethanol industry to value add by using these well established chemical processes to obtain production and efficiency metrics beyond which traditional grain based fermentation processes can offer.

### Ethanol From Carbonaceous Gas

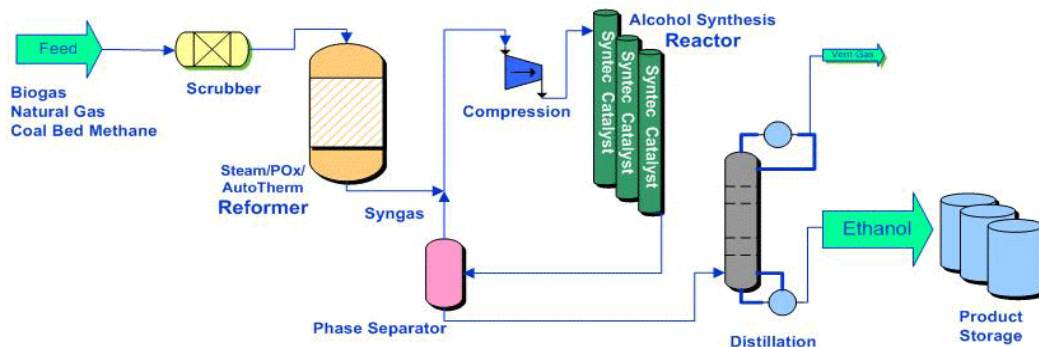

### Ethanol From Solid/Liquid Carbonaceous Material

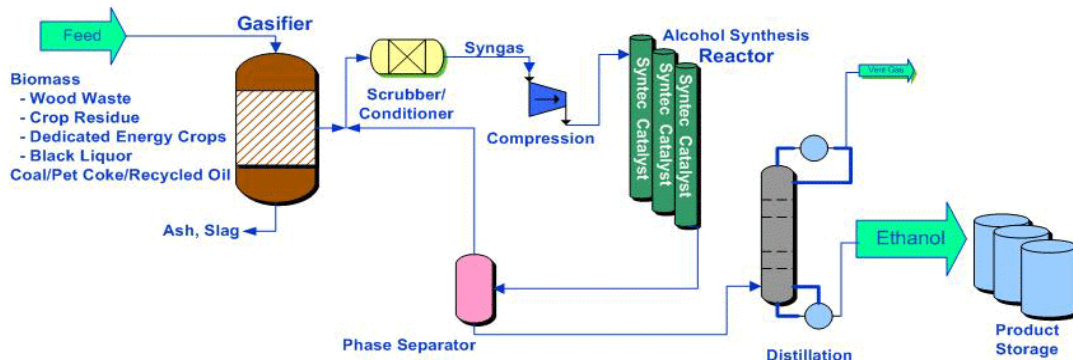

<sup>113</sup> <http://www.syntecbiofuel.com/technology.html>



## Detailed Process Description

There are 3 basic steps in the Syntec Process:

1. production of syngas (CO, H<sub>2</sub>) either through the gasification of biomass feedstock, or through steam reforming/partial oxidation of biogas or landfill gas,
2. conversion of syngas to bio-alcohols over Syntec catalyst in a fixed bed reaction unit,
3. separation and purification of bio-alcohols (high purity) to ethanol, methanol, n-propanol and n-butanol.

## Social Considerations

Unlike petroleum-based fuels, biofuels are made from an unlimited renewable resource base which makes them one of the cleanest ways to mitigate carbon dioxide, carbon monoxide, particulate and other green house gas emissions associated with global transportation.

Ethanol contains 35% oxygen by volume, is biodegradable, non-toxic and carbon neutral, however, the true ethanol superstar would be that which is made from renewable and renewable waste resources. Ethanol derived in said fashion holds the potential of dramatic environmental benefits on order of magnitude greater than any other biofuel production path save perhaps biodiesel made from algae

## Investments and Operating Cost<sup>114</sup>

Syntec has undertaken to raise up US\$3 million dollars to ramp up technical staff, purchase equipment and provide working capital for development, testing and quantifying the life of the catalysts prior to commercialization. Syntec's yield is equivalent to revenues in excess of \$27 million per year for a 300 ton per day biomass processing facility.

## Advantages to Developing Countries<sup>115</sup>

Perhaps the most important aspect of the Syntec Process is the ability to convert abundant, low cost (sometimes negative cost) waste products into ethanol and bio-alcohols without harming the agricultural land base or competing with consumable food stocks. These green biofuels significantly reduce green house gas emission. Moreover, enough biomass exists and is renewed every year in North America, and other parts of the world, to significantly reduce a country's dependence on imported oil required for petroleum derived fuels.

## Disadvantages to Developing Countries<sup>116</sup>

This source of biomass comes from the leftover organic material from crop harvesting. Corn stover, rice straw, and bagasse are all examples of agricultural residues. Presently, some residues are used as animal feed, but there are still significant surpluses in many regions. While using agricultural

---

<sup>114</sup> <http://bioenergyuiuc.blogspot.com/2008/02/syntec-biofuel-achieves-yield-of-105.html>

<sup>115</sup> <http://www.syntecbiofuel.com/technology.html>

<sup>116</sup> <http://www.syntecbiofuel.com/biofuel.html>

residues may present a logistical problem and supply may become a problem due to their seasonal availability.

### **Examples of Real Life Applications**

University of British Columbia

The University of British Columbia

2329 West Mall Vancouver, BC Canada V6T 1Z4

tel 604.822.2211 (Directory Assistance) |

### **Supplier**

#### **SYNTEC BIOFUEL INC.**

Phone: 604-648-2092

Email: [info@syntecbiofuel.com](mailto:info@syntecbiofuel.com)

## The IRRI DR-1 Batch Dryer<sup>117</sup> Philippines, Research

<b>Crop</b>	Rice
<b>Residue</b>	Hulls
<b>Process</b>	Combustion
<b>Equipment</b>	Semi-portable batch dryer
<b>Main Product</b>	Heat for drying

### Technical Description of Technology

The IRRI DR-1 Batch Dryer – Developed to provide low cost, improved alternative to sun drying. It utilizes engine heat and kerosene or rice hulls to raise temperature of the drying air. It can dry a ton of wet paddy in 3 to 6 hours depending on the initial grain moisture content. It is also compact and semi-portable, needs little maintenance and is easy to operate, gives uniform final moisture content, has an automatic safety valve to shut off kerosene burner when blower stops and it uses a direct fires burner for higher heat energy efficiency.



### Examples of Real Life Applications

IRRI, Laguna, Philippines

### Suppliers

International Rice Research Institute  
Los Baños, Laguna, Philippines

**Email:** [irri@cgiar.org](mailto:irri@cgiar.org)

---

<sup>117</sup> <http://www.irri.org/aed/aedbdr1.html>

**Mail:** DAPO Box 7777  
Metro Manila, Philippines  
Phone: +63 (2) 580-5600  
Fax: +63 (2) 580-5699

**Courier:** 6776 Ayala Ave.  
Security Bank Center, Suite 1009  
Makati City, Metro Manila, Philippines  
Phone: +63 (2) 891-1236,  
Fax: +63 (2) 891-1174

**Calling from the U.S.:**  
Phone: 1-650-833-6620  
Fax: 1-650-833-6621

**Rice Hull Furnace attached to a blower<sup>118</sup>**  
**Philippines, Research**

<b>Crop</b>	Rice
<b>Residue</b>	Hull
<b>Process</b>	Combustion
<b>Equipment</b>	Drying machine
<b>Main Product</b>	Heat for drying

**Technical Description of Technology**

The machine consumes 2-3 kg of rice hull per hour, with a drying temp of 43°C and a drying rate of 23% moisture (wet basis) paddy to 14% in 5 to 6 hrs.

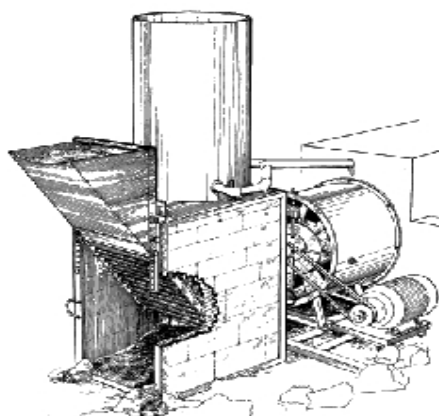

**Example of Real Life Application**

Research Philippines

**Supplier**

IRRI, Philippines

---

<sup>118</sup> <http://www.irri.org/aed/aedbdr1.html>

## **Combustion of Leached Rice Straw for Power Generation U.S.A., Research**

<b>Crop</b>	Rice
<b>Residue</b>	Rice Straw
<b>Process</b>	Combustion
<b>Equipment</b>	Traveling Grate, Circulating Fluid Bed, Suspension fired technology
<b>Main Product</b>	Fuel and Electricity
<b>By-Product</b>	Ash

### **Technical Description of Technology**

Rice straw was fired in three different types of existing commercial boilers ranging in size from 18 to 26 MWe: a stoker-fired traveling grate, a circulating fluidized bed (CFB), and a suspension fired unit. In each case, 33 metric tons of straw was blended 20 to 25% with the plant's standard fuel. For the grate unit the straw was blended with forest-derived wood fuel, for the CFB with a blend of urban wood and agricultural wood, shells, and pits, and for the suspension unit with rice hulls. Deposition probes were installed at the superheaters to detect changes in fouling and stack sampling was performed to monitor changes in silica, total particulate matter, and other plant emissions. No adverse effects due to slagging or fouling were observed, and no bed agglomeration occurred in the CFB. NO<sub>x</sub> emissions increased for the grate and CFB units due to the higher nitrogen content of the straw, and required increased ammonia injection for control. NO<sub>x</sub> emissions did not increase for the suspension unit normally firing rice hull. The experiments demonstrate the technical feasibility of using leached rice straw as fuel in conventional power stations employing various combustion technologies.

### **Detailed Process Description**

The stoker-fired traveling grate boiler was one of three identical boilers providing steam to a common header supplying three turbo-generators totaling 50 MWe net output. The CFB boiler was a single unit with a 25 MWe net output. The suspension-fired boiler was also a single unit with a 26.5 MWe net output. The tests were carried out under rated load conditions with the exception of the suspension-fired unit. In that case, problems with the baghouse just before the first straw test prevented operating above 20 MWe. All tests, including baseline, were conducted at 20 MWe even after the baghouse was fixed. The furnace exit gas temperature (FEGT) was therefore lower than at peak load. No soot blowing occurred during testing. Leached straw was blended with the baseline fuel so as to make up 20 to 25% of total heating value. During testing, samples of fuel, bottom ash, and fly ash were collected at regular intervals. Bottom ash (bed)

was not continuously discharged from the CFB. To monitor potential superheater fouling, in each test a deposit probe was inserted into the boiler just upstream of the leading superheater. The probe was a section of tube of the same SA213-T22 steel used in the plant superheaters, air-cooled to approximately the same metal temperature as the actual superheaters (500°C). After removal, deposits collected on the probes were visually inspected and then recovered by rinsing with distilled water.

Rinsates were filtered and filter cake and filtrate analyzed for elemental composition. Total deposit mass was reconstructed via mass balance. Fireside deposits on superheaters and other plant equipment were also monitored visually. To test for changes in stack particulate matter emissions, filter samples were collected from the stacks during both baseline and straw blend fuel tests using a standard EPA method 5 sampling train. The traveling grate unit utilized an electrostatic precipitator (ESP) for particulate matter emission control. The other two facilities employed baghouses. The grate and CFB units used ammonia injection for NO<sub>x</sub> control, the suspension-fired unit used exhaust gas recirculation.

### **Main Products**

Fuel in conventional power stations employing various combustion technologies.

### **Environmental Considerations**

Unfortunately, rice straw, as it is available immediately following grain harvest, contains a combination of silica and potassium that leads to heavy slagging and fouling if fired in conventional combustion power plants. Chlorine in straw also accelerates corrosion in furnaces and boilers. Potassium and chlorine are readily leached with water from biomass, including straw. Such leaching occurs naturally when straw is exposed to rain. Leaching can also be effected through various mechanical treatments. In either case, the result is a remarkable improvement in combustion behavior leading to substantially higher ash fusibility temperatures and lower alkali and halogen volatilization. Improvements to the combustion properties of rice straw via leaching have been well demonstrated in the laboratory. Preliminary full-scale experiments with leached rice straw were carried out successfully in a stoker-fired traveling grate boiler.

### **Examples of Real Life Applications**

Department of Biological and Agricultural Engineering, University of California, One Shields Avenue, Davis, California 95616-5294

### **Sources:**

4. <http://faculty.engineering.ucdavis.edu/jenkins/projects/Leaching/4thBCofAPaper.pdf>

**Fruit Drier 200<sup>119</sup>**  
**Philippines, Research**

<b>Crop</b>	Rice
<b>Residue</b>	Hull
<b>Process</b>	Combustion
<b>Equipment</b>	FD 200 cabinet type biomass dryer
<b>Main Product</b>	Heat for drying

**Technical Description of Technology**

IAE/UPLB developed the FD-200 cabinet type biomass dryer, which uses rice husk as the fuel.<sup>120</sup> This dryer was demonstrated in a medium-scale fruit processing company, which required a fairly large drying capacity. The dryer has the capacity to accommodate 200 kg of sliced fruits.

**Design details**

The dryer consists of a drying chamber and a biomass furnace-heat exchanger unit. The biomass furnace uses ricehusk as fuel, which is fed to the furnace by an automatic feeder arrangement. An air distribution system distributes hot air evenly to the several trays inside the drying chamber. The technical specifications of the dryer are given in Table 9.1. The design of the dryer is illustrated in Figure 9.2.

Table 9.1: Technical specifications of the cabinet dryer FD200<sup>121</sup>

Sl. No.	Parameter	Specification
1.	Drying capacity per batch	200 kg (sliced mango)
2.	Average drying air temperature	53°C
3.	Airflow rate	0.37 m <sup>3</sup> /hr
4.	Dryer Dimensions	2.90 x 1.37 x 2.00 m
5.	No. of trays	52 of 0.98x0.97 m size
6.	Total tray area	48.4 m <sup>2</sup>
7.	Fuel type, and consumption	Rice husk; 11-15 kg/hr
8.	Heat exchanger type	Shell and tube

Fruit Drier 200 is a tray type drier that uses biomass energy. The furnace on the other hand is composed of a hopper with a capacity of 2 sacks of rice hull per loading which lasts for about 2 to 3 hours. A heat exchanger, which is composed of 27 boiler tubes having a diameter of 2-1/2" and arranged in regular triangular array was also added in the design. A chimney with a 6" diameter serves as the exhaust of smoke.

<sup>119</sup> <http://www.uplb.edu.ph/ceat/research/fruitdry/index.htm>

<sup>120</sup> <http://www.retsasia.ait.ac.th/booklets/Dissemination%20Booklets-Phase%20III/Tech%20pack-Dry-low%20resl.pdf>

<sup>121</sup> *ibid.*



## **Detailed Process Description**

### ***Drying chamber***

The drying chamber, 1.37m wide, 2m tall and 2.9m long, contains two movable tray carts having 26 trays each. It is made of galvanized iron sheets framed together by angular steel bars. The trays (of dimensions 0.98m x 0.97m) are made of polyethylene plastic mesh reinforced with aluminum bars. The total area of the drying trays can accommodate 200 kg of mango slices. The chamber also has an air distribution system, which ensures distribution of air into the entire height of the chamber. The air distribution system is composed of an axial fan (with a 0.35m dia. rotor) and a distributor duct. The distributor duct has a converging shape from top to bottom, and has thirteen concentric rings of varying diameter, arranged one above the other, at specific spacing. This system can deliver an air volume of up to 0.37 m<sup>3</sup>/sec.

### ***Biomass furnace - Heat exchanger***

The rice husk-fuelled furnace is composed of five parts: the combustion chamber, heat exchanger system, fuel hopper, air inlet duct, and the chimney. The combustion chamber is made of bricks enclosed in galvanized sheet metal while the heat exchanger system is made of 27 boiler tubes arranged in a rectangular array. All other parts of the furnace are made of galvanized iron sheet. A butterfly valve controlled by a variable speed electric motor (0.5 hp) controls the feed rate of rice husk; the fuel hopper is inclined at 45° (angle of repose of rice husk) to allow free flow of rice husk into the combustion chamber. An auxiliary blower (0.5 hp) was installed in the combustion chamber to supply the primary air required for complete combustion. The primary air supply to the furnace can be controlled by adjusting the opening of the blower air inlet. The main blower installed between the furnace and the drying chamber draws the ambient air through the furnace-heat exchanger unit, and supplies hot air to the drying chamber. An S-shaped duct is installed at the air inlet to the heat exchanger. The mouth of the duct is located away from the combustion chamber to avoid suction of ashes that may otherwise contaminate the product to be dried. The fuel hopper has a capacity of three sacks of rice hull per loading which lasts for about 3 to 4 hours of dryer operation.

The dryer has been tested with mango and banana. The quality of the dried banana and mango were found to be very good, with no browning observed.

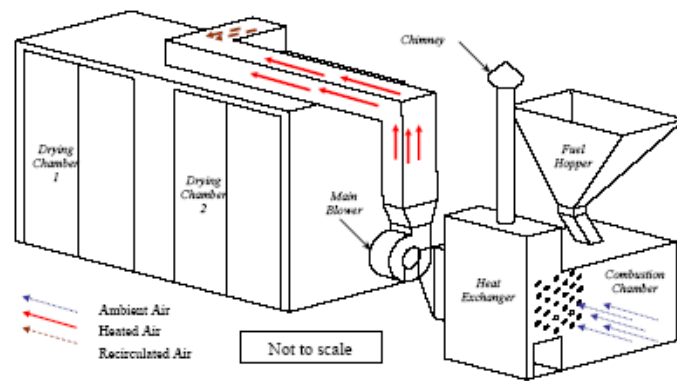

Figure 9.2: Schematic of the rice husk-fuelled drying system FD200



The rice husk-fuelled cabinet dryer FD-200

### Price of Machine

The total cost of fabricating this dryer is about US\$1,800.

### Examples of Real Life Applications

Research IAE/UPLB

### Supplier

IAE/UPLB

University of the Philippines Los Banos  
Laguna, Philippines

## **Rice Hull Ash Cement (RHAC) Hollow Blocks<sup>122</sup>** **Philippines, Research**

<b>Crop</b>	Rice
<b>Residue</b>	Hull Ash
<b>Process</b>	Densification
<b>Equipment</b>	Mold
<b>Main Product</b>	Hollow blocks

### **Technical Description of Technology**

Ricehull-ash-cement (RHAC) hollow block is a combination of refined ricehull ash, cement and sand. These blocks are as durable as the concrete hollow blocks yet much cheaper. Rice hull contains high temperature forms of silica, which in amorphous state (burned between 700 to 750oC) is pozzolanic or possesses binding property. But at very high temperatures (beyond 750oC), the amorphous silica turns crystalline, thus losing its binding property. Since natural pozzolanas are usually of volcanic origin and occur in only a few regions of the world, artificial pozzolanas such as rice hull ash cement are needed to serve as cement substitutes.

### **Detailed Process Description**

Hollow Blocks From Rice Hull Ash

Procedure<sup>123</sup>:

1. Burn rice hull into ashes.
2. Refine the ashes.
3. Mix the following:
  - o 60 parts of cement
  - o 40 parts of rice hull ash
  - o water
4. Put in a wooden mold.
5. Let it dry.

### **Specific Considerations for Developing Countries**

RHAC blocks can be mass-produced for low-cost housing projects, while at the same time ease the disposal of rice hull waste. The raw materials are readily available and inexpensive, while the processing equipment can be made locally. Ash from incinerated rice hull can replace considerably the Portland cement used in construction.

---

<sup>122</sup> <http://www.uplb.edu.ph/community/fprdi/commtech/rhac.htm>

<sup>123</sup> <http://entrepinoys.blogspot.com/2007/09/clay-bricks-hollow-blocks-from-cheap.html>

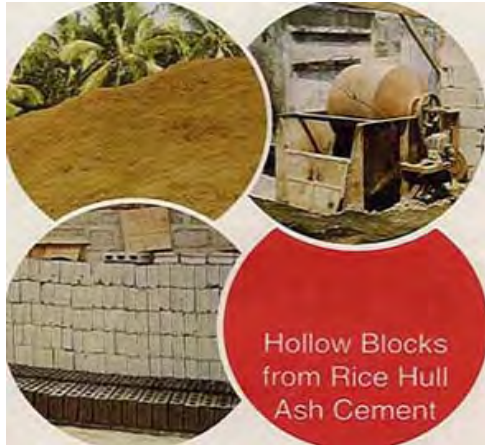

### **Example of Real Life Applications**

Research

UPLB Philippines

### **Supplier**

University of the Philippines Los Banos  
Laguna, Philippines

## **Details of Technologies**

### **1. Waste to Material Conversion**

#### **A. Technologies in Commercial Use**

**Grenidea AgroResin<sup>124</sup>**  
**Singapore, Commercial**

<b>Crop</b>	Oil palm frit, wheat
<b>Residue</b>	Oil palm fruit residue
<b>Auxiliary materials</b>	Wheat straw fibers
<b>Process</b>	Recycling
<b>Equipment</b>	Mold
<b>Main Product</b>	Biodegradable packaging materials

**Technical Description of Technology**

Air permeability: High porosity depending on product thickness and density

Appearance: Fibrous

Burst Index: >1.5 kpa.m<sup>2</sup>/g

Color: Natural, choice of dyes

Density: 0.40-0.60 g/cm<sup>3</sup>

Material: Lignocellulosic agrocomposite biomass

Printability/Embossing: good

Sealing: Plastic lid, lamination

Shelf month: 12 months

Temperature Tolerance: minimum 25C, maximum 180C

Thickness: 0.85-1.55 mm.

Water absorption: Cobb 120 < 25 g/m<sup>2</sup>

**Detailed Process Description**

Supply Chain

Grenidea

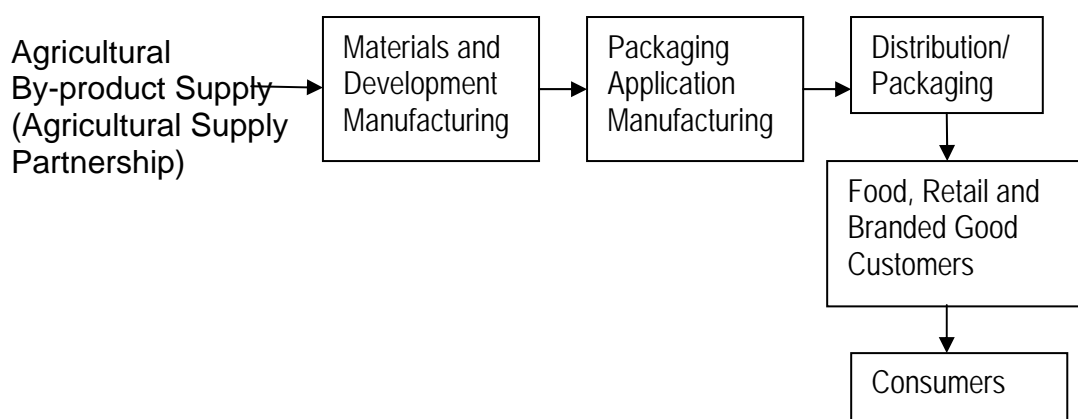

<sup>124</sup> <http://www.grenidea.com/>

Through a joint venture component materials manufacturer, Grenidea obtains agricultural waste biomass from plantation owners. It then provides packaging manufacturers with technologies and these raw materials for conversion into green packaging. Finally, it markets the environmentally sustainable packaging products to retailers of fresh food produce.

### **Main Products**

Biodegradable packaging that are used to package fresh fruits and vegetables. AgroResin packaging can be used for packaging a variety of food produce, including dried food, bakery products and frozen food

### **Job Potential**

It plans to grow its current staff strength of 12, as well as raise the volume of production.

### **Specific Considerations for Developing Countries<sup>125</sup>**

AgroResin brand of packaging to overseas markets such as Europe, North America, Australia and Scandinavia. These markets are more environmentally aware, making it easier for Grenidea to find ready customers there. On average, the price of its agro-fibre trays is about 30 per cent higher than styrofoam.

### **Environmental Considerations**

Biodegradable and compostable

### **Investment and Operating Cost**

On average, the price of its agro-fibre trays is about 30 per cent higher than styrofoam. Going forward, it is looking at converting agricultural waste from rice and wheat straw into packaging, said Dr Xu. It plans to grow its current staff strength of 12, as well as raise the volume of production.

### **GHG Emission Reduction Potential<sup>126</sup>**

The Biodegradable Products Institute (BPI) announced its approval of Grenidea's AgroResin materials derived from renewable agricultural biomass. The BPI's certification demonstrates that Grenidea's products meet the specifications in ASTM D6868 and will biodegrade swiftly and safely during municipal or commercial composting.

### **Advantages to Developing Countries**

Grenidea's research lab is based in Singapore, and focuses on the conversion of biomass to biodegradable materials. Going forward, it is looking at converting agricultural waste from rice and wheat straw into packaging.

---

<sup>125</sup> <http://www.grenidea.com/pdf/Today%20News%20Article%20on%20Grenidea.pdf>

<sup>126</sup> <http://www.grenidea.com/pdf/ATTO0007.pdf>

## Example of Real Life Applications<sup>127</sup>

**Level of Use** Commercial  
**Name of Project** Grenidea Technologies  
**Location** Singapore

### Suppliers

Grenidea Technologies Pte. Ltd. Singapore  
67 Ayer Rajah Crescent, # 02-07/08/09  
Singapore 139950  
Tel. No. 65 6872 0020  
Fax No. 65 6872 0460  
Email: e.info@grenidea.com

128



**PUT WASTE TO GOOD USE: The fibre of the oil palm (left) is processed and converted to packaging such as trays (right).**

<sup>127</sup> <http://www.grenidea.com/pdf/Today%20News%20Article%20on%20Grenidea.pdf>

<sup>128</sup> [ibid.](#)



## Abaca Mechanical Tuxer<sup>129</sup> Philippines, Commercial

<b>Crop</b>	Abaca
<b>Residue</b>	Leaves
<b>Process</b>	Tuxying
<b>Equipment</b>	Mechanical Tuxer, feeding table, guide roller, knife assembly, presser, puller, power drive, foot pedal, frame assembly
<b>Main Product</b>	Abaca leaf sheath
<b>By products</b>	Fibers

### Technical Description of Technology

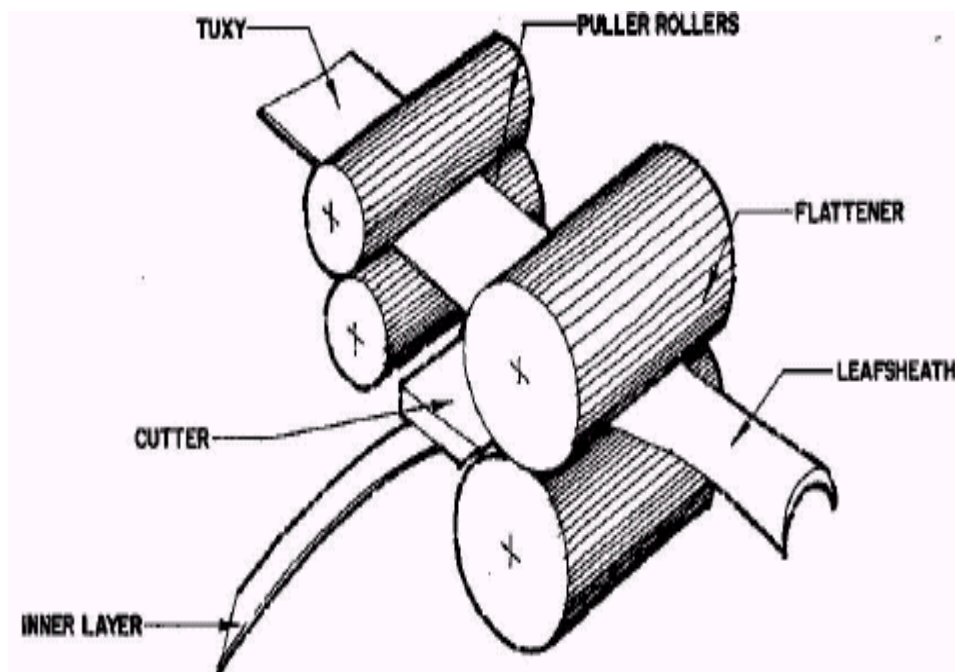

The leaf sheath inserted between the first two rollers passes through a knife that separates the outer from the inner part of the leaf sheath. The second pair of roller pulls out the tuxy.

### Detailed Process Description

The machine consists of a feeding table, guide roller, knife assembly, presser, puller, power drive, pedal, and frame assembly. A set of rollers is mounted in the feeding table to allow the leaf sheath to move freely towards the knife. This is followed by a guide roller that directs the leaf sheath to the blade assembly. A roller is mounted and pressed on top of the knife assembly. It flattens the leaf sheath as it goes through the knife. The knife then cuts and

<sup>129</sup> [http://www.unido.org/file-storage/download/?file\\_id=48269](http://www.unido.org/file-storage/download/?file_id=48269)

separates the outer from the inner portions of the leaf sheath as two contra-rotating rollers pull it out. The whole assembly is mounted on a frame with two wheels and handle for easy transport. In operating the machine, the foot pedal is pressed down to create an opening between the presser and the puller. The leaf sheath is then inserted in the opening between the two rollers. The foot pedal is released and the tuxy is manually pulled. A 4Hp gasoline engine is used to power the machine.

### Main Products

Abaca fiber is extracted from the leaf sheath traditionally by stripping using either manual or mechanical process. When either of the process is used, tuxying is employed. Tuxying is the process of separating the outer leaf sheath, which contains primary fibers, from the inner leaf sheath, where secondary fibers are found. The separated outer leaf sheath is called tuxy.

### Job Potential

Since leaf sheathing is included in the workflow in mechanical tuxying, total manhour spent is higher, that is; 3:37 compared to 1:28 employing the manual process. An advantage of the mechanical tuxer is that it produces more tuxies, with 78.12 kgs and, therefore, higher fiber yields, by 22.75%.

### Operation and Maintenance Requirements

- Maximum capacity of 500 kgs of tuxies to serve 13 has of abaca plantation
- Easy to operate and maintain
- Can be pulled by a carabao
- Low cost, affordable to a middle-income farmer or a small abaca farmers' association

### Social Considerations

Using the spindle stripping machine, S2 and S3 grades of abaca fiber were produced. Since the tuxies produced by the manual method are made almost all of primary fibers, the amount of S2, which is 91.25%, is slightly higher than the 90.73% produced from the mechanical tuxer. But because the mechanical process produces more fiber, income is higher with Php181.64 compared to Php148.80 from the traditional method. However, the high cost involved in mechanical tuxying made the use of the manual process more profitable.

### Investment and Operating Cost

Table 1. Comparative cost to tuxy using manual and mechanical method, 300 kgs abaca stalks, (Peso)

Particulars	Mechanical tuxer
Labor	45.25
Fuel	51.21
Depreciation cost Tools	-
machine	4.87
Total	101.33

### **Economic instruments for overcoming barriers**

The Department of Agriculture provided the funds for this project through the High Value Commercial Crops Program (HVCCP). The project aims to increase farmers' income by improving fiber quality through the mechanization of abaca fiber extraction.

### **Advantages to Developing Countries**

Abaca is endemic to the Philippines. Being so, the country holds the largest number of abaca germplasm, perhaps, as many as 200 varieties, of which about 20 are cultivated commercially. Owing to the wide range of climates existing in the country, adaptation of abaca has always been believed to be location specific. For instance, Bicol varieties are observed to have shorter and slimmer stalks and better anchorage and therefore, more typhoon resistant than varieties found in Mindanao.

### **Disadvantages to Developing Countries**

Although the field test indicated that the tuxer can produce more tuxies than the traditional tuxying tools, it requires more man-hour and appears to be more expensive with the added cost of fuel and depreciation. Future research must be focused on developing a machine that is more efficient and affordable to farmers.

### **Example of Real Life Applications**

**Level of Use:** Demonstration Level

**Name of Project:** Abaca Mechanical Tuxer

**Location:** Philippines

### **Supplier**

Department of Agriculture

FIBER INDUSTRY DEVELOPMENT AUTHORITY

Asiatrust Bank Annex Building

1424 Quezon Avenue, Quezon City, Philippines

<http://fida.da.gov.ph/>

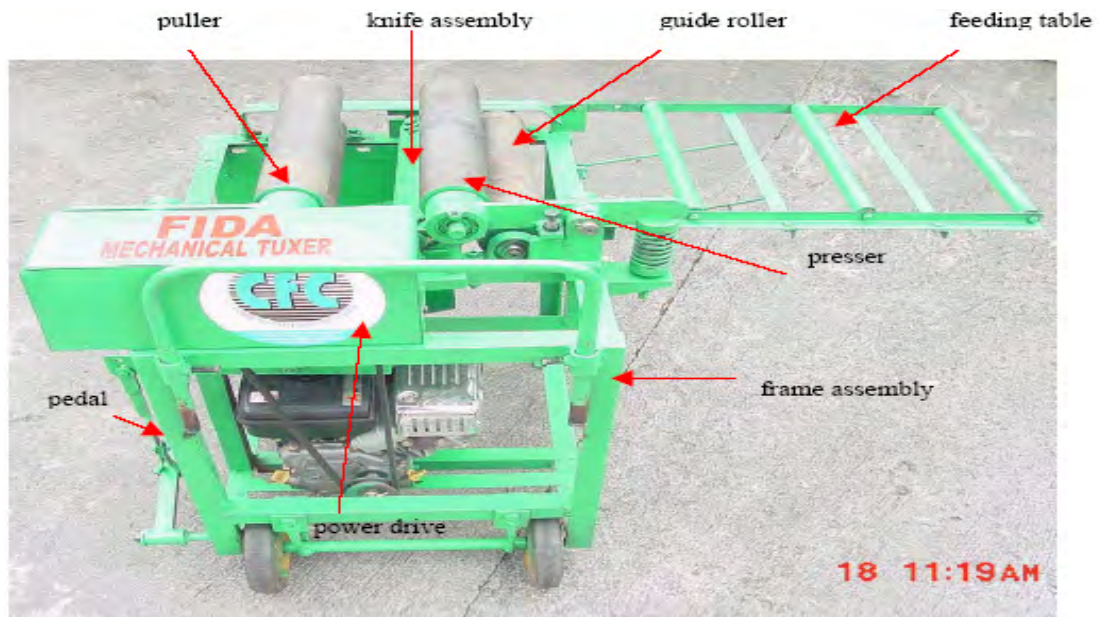

## Ropes from Abaca Fiber Philippines, Commercial

<b>Crop</b>	Abaca
<b>Residue</b>	Fiber
<b>Process</b>	Decortification
<b>Equipment</b>	Mobile Abaca Spindle Stripping Machine, Fiber Twisting Machine, multi-fiber decortivating machine
<b>Main Product</b>	Yarn
<b>By products</b>	Ropes and other products

### Technical Description of Technology



**Figure 1. Portable Abaca Spindle Stripping Machine**

- 105cm. L x 100cm. W x 110cm H with coil spring, idler clutch, a spare blade, bolted and dismountable framing weighing 180kg including engine
- Traditional stationary machine was modified for easy and safe operation and extraction of good quality abaca fiber with 100-150kg dried fiber output capacity/day (depends on skill of operator)
- Can serve 15 to 20 has. of abaca plantation/unit
- Patent Number : 2-1997-15460



**Figure 2. Fiber Twisting Machine**

- 100cm x 61 x 72cm machine that makes 1/8" to 3/8" diameter abaca twisted yarn from different kinds of hard fiber materials
- Yarn can be used in the production of twine or rope that can be directly woven to produce rugs, copra, sacks, and other decorative item
- Yarning Capacity: 300 to 400m/hr using abaca fiber & 200 to 300m/hr using "bacbac" material
- Machine Cost: P30, 000 per unit including motor.

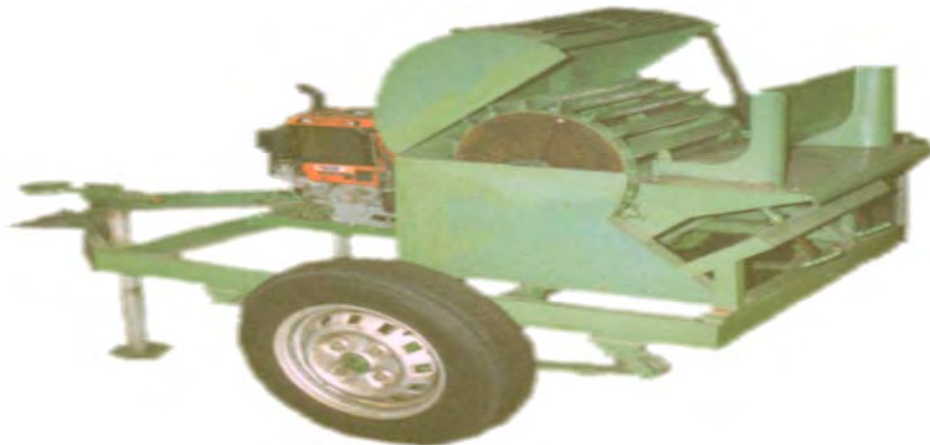

**Figure 3. Decortivating Machine**

<sup>130</sup>Decortivating machines are used to extract fibers from abaca and piña leaves by means of crushing and scraping processes. The extracted fibers are sun-dried and further processed into fabric/textile products or handicraft and decorative items. The machine consists of the following parts: frame and chassis, underchassis and tires, paddle wheels, feeding gate and an adjustable anvil.

---



## Detailed Process Description

**Spindle-Stripping** - A semi-mechanized process of extracting fiber. The tuxy is fed into the stripping knife of the machine and extraction is done by spindle rotated by a motor. Output is between 80-120 kg fiber per man-day.

**Mobile Spindle Stripping Machine** is an agricultural machine that is used in the extraction of fiber from abaca leafsheath through the pressing and pulling action of the two blades and a taper roller spindle, respectively. With an improved blade and roller, the usual manual stripping operation will become unnecessary because the ends of the abaca leafsheath shall be wrapped around the machine-assisted roller spindle, pulling out easily the fiber strip thus, creating less effort on the part of the operator.

**The multi-fiber decorticating machine** is an improvement of the traditional 'raspador' decorticator used for ramie fiber extraction. It has higher recovery for abaca since the primary and secondary fibers are recovered. It can be moved from one plantation to another. It can extract fibers from pineapple and banana leaves, which are plantation wastes. It is easy to operate and maintain.

### Advantages to Developing Countries

<sup>131</sup>Abaca has been grown in the Philippines for centuries and was known to the Filipinos long before the Spanish occupation. The crop has been proven to be profitable and has continuously provided income to many Filipinos, especially those in the uplands of Mindanao, for their subsistence.

### Disadvantages to Developing Countries

The abaca industry is expected to continue making a stronghold in both the domestic and international markets. Below is a summary of the opportunities, prospects and developments in the abaca industry.

- Strong demand for abaca as a result of the expanding market for specialty papers for food packaging as in tea bags and meat casings, filter papers, non-wovens and disposables.
- Growing demand to conserve forest resources and to protect the environment from problems posed by non-biodegradable materials, particularly plastics, contributed to the growing demand for natural fibers like abaca.
- Due to the environmental degradation, Japan, which is one of the major abaca consumers, is now replacing PVC with natural fibers or materials free from chlorine.
- Development of new uses for abaca such as textile materials for the production of pinukpok or as blending material, with silk, piña or polyester, in the production of high-end fabrics.
- Growing demand for handmade paper as art media, photo frames, albums, stationery, flowers, all purpose cards and decoratives.

## **Example of Real Life Applications**

**Country:** Philippines

**Level of Use:** Commercial

### **Supplier:**

Parasan Rope Makers Association  
Barangay Parasan, Molave, Zamboanga Del Sur

Department of Science and Technology  
Regional Office No. I  
DMMMSU Mid La Union Campus  
City of San Fernando  
2500 PHILIPPINES  
Telefax # (+6372) 242-4878  
Email Address: [dostro1@dost.gov.ph](mailto:dostro1@dost.gov.ph)  
Website: <http://region1.dost.gov.ph>

### **Sources:**

1. <http://region1.dost.gov.ph/mature%20tech/htm%20files/abacaspindle.htm>
2. <http://region1.dost.gov.ph/mature%20tech/htm%20files/fibertwisting.htm>
3. <http://setup.dost.gov.ph/commerce.php?view=182>
4. <http://www.mixph.com/2008/02/production-guide-on-abaca.html>

## **AgriRange Fuel Thermal Chemical USA, Commercial**

<b>Crop</b>	Agricultural products
<b>Residue</b>	Agricultural waste
<b>Process</b>	Thermo Chemical Process
<b>Equipment</b>	
<b>Main Products</b>	Cellulosic Ethanol

### **Technical Description of Technology:**

Thermo-chemical processes use various combinations of temperature, pressure, residence time, water, oxygen or air, and catalysts to convert biomass to cellulosic ethanol. These processes transform all of the non-mineral constituents of the biomass into a common form – synthesis gas or syngas. The syngas is passed over a catalyst, which acts much like the catalytic converters used in automobiles, and converts it into ethanol and other alcohols. As with the sugar-platform process, the final step includes separation and concentration.

Besides producing ethanol and other alcohols, the syngas can be used to produce synthetic petroleum products, fertilizer, plastics, and many other products. It can also be used as a fuel to generate electricity.

### **Detailed Process Descriptions:**

#### **Step 1: Solids to Gas**

Biomass (all plant and plant-derived material) that cannot be used for food, such as agricultural waste, is fed into a converter. Using heat, pressure, and steam the feedstock is converted into synthesis gas (syngas), which is cleaned before entering the second step.

#### **Step 2: Gas to Liquids**

The cleaned syngas is passed over our proprietary catalyst and transformed into mixed alcohols. These alcohols are then separated and processed to maximize the yield of ethanol of a quality suitable for use in fueling vehicles.

#### **A Simple Process**

Because Range Fuels' process utilizes a thermo-chemical process, it relies on the chemical reactions and conversions between forms that naturally occur when certain materials are mixed under specific combinations of temperature and pressure. Other conversion processes use enzymes, yeasts, and other biological means to convert between forms.



**Main Products:** Cellulosic Ethanol

### **Operation and Maintenance Requirements:**

The company is backed by an undisclosed amount from Khosla Ventures and a \$76 million federal grant from the DOE. This morning Range Fuels also said that its \$76 million grant, which it first announced in February, has been signed and that they've agreed to the terms and appropriation of funds. The first \$50 million will go towards this first phase of the plant, and the remaining \$26 million will go towards the next phase of the project.

### **Social Considerations**

The thermochemical route to biomass conversion does appear to be more flexible in its acceptance of variable and blended feedstock. Using heat instead of enzymes to break molecular bonds not only saves the price of enzymes but dramatically reduces the need for water - not an insignificant issue, particularly in the face of mounting concern about

### **Investments and Operating Cost**

Range Fuels' technology has been tested and proven in bench and pilot-scale units for over 7 years. Over 8,000 hours of testing has been completed on over 20 different non-food feedstocks with varying moisture contents and sizes, including wood waste, olive pits, and more. This technology will be used in our first plant planned for a site near Soperton, Georgia.

### **Advantages to Developing Countries**

The Range Fuels process accommodates a wide range of organic feedstocks of various types, sizes, and moisture contents. This flexibility eliminates commercial problems related to fluctuations in feed material quality and ensures success in the real world, far from laboratory-controlled conditions.

### **Disadvantages to Developing Countries**

Thermo-chemical processes consume energy and use expensive materials to withstand the temperatures and pressures necessary to convert the biomass into cellulosic ethanol. To reduce production costs, focus will be placed on advances in materials design and process efficiency.

### **Examples of Real Life Applications**

Range Fuels  
11101 W. 120th Avenue, Suite 200  
Broomfield, CO 80021  
Phone: 303-410-2100  
Fax: 303-410-2101  
General Inquiries: [info@rangefuels.com](mailto:info@rangefuels.com).

## AgriWaste BEST Pyrolysis Australia, Commercial

<b>Crop</b>	Agricultural Products
<b>Residue</b>	Agriwaste
<b>Process</b>	Carbonization
<b>Equipment</b>	
<b>Main Products</b>	synthesis gas and carbon-rich end materials

### Technical Description of Technology:

Figure 1.

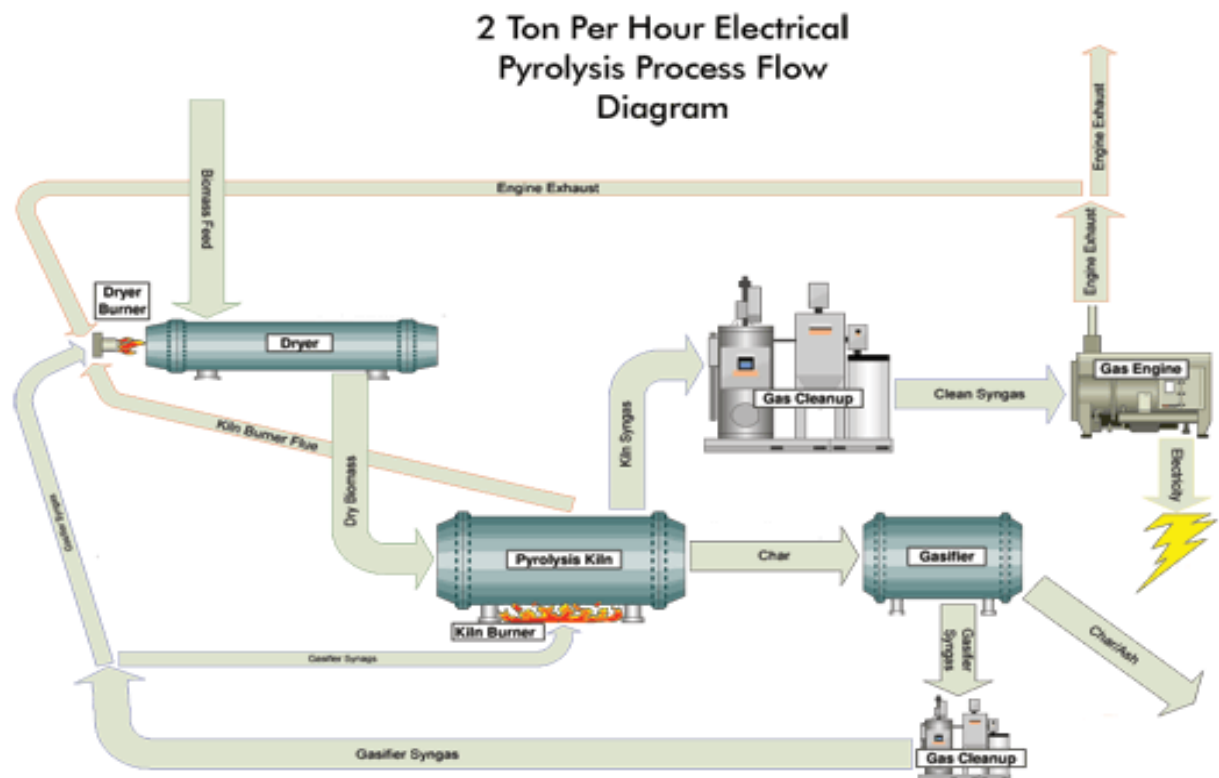

### Detailed Process Descriptions:

Slow pyrolysis is a thermochemical decomposition of organic material at elevated temperatures in the absence of oxygen. The feed material is dried and fed into a stirred, heated kiln. As the material passes through the kiln, a combustible synthesis gas (syngas) is evolved and is continuously removed from the kiln. Approximately 35% by weight of the dry feed material is

converted to a high-carbon char material that is collected on the discharge of the kiln.

### **Main Products:**

The main products are synthesis gas and carbon-rich end materials.

#### **Synthesis Gas**

1. Syngas can be used to dry the incoming feed material, fuel an engine or a gas turbine.
2. Syngas can be used as a feedstock for a secondary refining process.
3. Syngas can be used as a natural gas replacement.

Carbon-rich end materials include char that can be made into:

1. Carbon filtration media
2. Pelletized fuel
3. Carbon for soil enrichment

### **Operation and Maintenance Requirements:**

The system can burn 300kg per hour of various biomass waste materials.

### **Social Considerations**

The systems are fully continuous and the pyrolysis kiln design lends itself to a variety of feed streams, improving the ability to utilize a diversity of local biomass resources in the community. A unique gas cleanup system effectively destroys tars making the syngas clean, reliable and efficient for downstream applications.

Also, research from the University of South Wales revealed that Agrichar product from the BEST pyrolysis technology significantly improved soil health and crop productivity.

### **Investments and Operating Cost**

Approximately 35% by weight of the dry feed material is converted to a high-carbon char material, which is a product in its own right as a soil amendment, fuel or filtration media. As proof of concept, BEST Energies Australia has a fully operational 300 kg/hr demonstration plant.

### **Advantages to Developing Countries**

1. Fully continuous and small footprint for stand alone or integrated combined heat and power applications
2. A tool to help actively manage CO<sub>2</sub> emissions derived from biomass waste streams
3. Minimization of volatile gases and odors from decomposing biomass streams

4. Creation of char to sequester CO<sub>2</sub> in soils
5. Reduces landfills and hauling of biomass (waste) streams
6. Utilizes the site's local biomass resources for clean energy production

### **Examples of Real Life Applications**

Pilot project in Somersby, on the Central Coast of New South Wales, Australia

### **Suppliers**

BEST Energies Australia Pty. Ltd.  
56 Gindurra Rd  
Somersby, NSW 2250 Australia  
Phone: (+61) 2 43404911  
email: [info@bestenergies.com.au](mailto:info@bestenergies.com.au)

BEST Energies, Inc.  
8000 Excelsior Drive  
Madison, Wisconsin 53717  
United States of America  
Phone: (608) 827-2970

### **Sources:**

## **NovaGreen Biomass Ethanol Separation Technology Canada, Commercial**

<b>Crop</b>	Sugarcane, Corn
<b>Residue</b>	Bagasse, corn stover
<b>Process</b>	Fermentation
<b>Equipment</b>	Thermal Shockwave System
<b>Main Products</b>	Xylitol, Lignin, unbleached cellulose, sorbitol and fructose

### **Technical Description of Technology:**

NovaGreen Inc., through its EXL Biomass Refining Division, has developed an advanced technology to produce cellulosic ethanol, and other products, from various organic feedstock, using steam explosion and fermentation technology. The Thermal Shockwave Systems Process (TSSP) is unique to the marketplace, and will produce several high value products from a single separation process. Input feedstock for the process will include straw from a wide variety of wheat, canola, triticale, flax, and other locally grown crops. Outputs include: Cellulose (which will be refined into Ethanol); Xylan/Xylitol, a high value sugar replacement product; and Lignin, which has numerous industrial and agricultural uses. Ethanol, Xylitol, and Lignin are the 'EXL' in EXL Biomass Refining. In addition to fuel grade Ethanol, both Xylitol and Lignin have wide ranging and profitable commercial applications, based on the high quality of the Thermal Shockwave System Process.

### **Detailed Process Descriptions:**

During the NovaGreen BEST process, neutral sugars (xylose and mannose) are extracted from organic feedstocks by water. (The lignin, which is not water soluble, is extracted separately)

First the straw is cleaned, and then it is separated in a huge reactor by injecting steam to break out the cellulose, sugars and lignin (the glue in plants and trees). The unbleached cellulose is collected and fermented in big tanks. To get to the final step, mineral enzymes (non polluting) and ethanol is added to the fuels. The carbon dioxide produced in the process is piped a short distance to the greenhouses. The CO<sub>2</sub> is used in the greenhouse growing process to enhance growth rates and greenhouse production, especially in winter months. By redepoying the CO<sub>2</sub> in this manner, we limit our (already small) CO<sub>2</sub> emissions ever further, and add value to our own internal processes.



The xylose sugar, which comprises about 80 - 90% of the water soluble neutral sugars, converts to furfural (an industrial solvent) or to xylitol, a sweetener similar to glucose. Xylitol has a proven therapeutic value in the prevention of dental carries and plaque (Oral Health – September 1988).

**Main Products:** Xylitol, Lignin, unbleached cellulose, sorbitol and fructose

The current major market for xylitol is for chewing gums, a small health food market and dental care uses. Health organizations are actively promoting the use of xylitol in various countries. In the United States, the Federal Food and Drug Administration (FDA) has approved xylitol for special dietary uses (FDA reference – 172.395). The Canadian Food Inspection Agency has approved xylitol as a food additive that can be used as a sweetener. In Europe and Asia, xylitol is promoted as a cavity fighter.

The dissociated feedstock material after the water extraction, when combined with a non-toxic catalyst can produce a hard, plastic-like material called lignin that can be used for the production of construction materials, furniture components and other related items. In addition, the dissociated feedstock material can be recombined in a variety of other ways to produce a range of finished materials using this technology.

### **Operation and Maintenance Requirements:**

Cellulose Xanthate, the first cellulose derivative for producing rayon is not a chemically stable product. Thus, the conversion of the cellulose to xanthate has to be made at the spinning or casting facilities.

### **Social Considerations**

Ethanol produced from cellulosic feedstock contributes to the long term viability of ethanol as a competitive and cost effective complement to non-renewable petroleum production.

### **Economic Instruments for Overcoming Barriers**

NovaGreen Inc. is working closely with the local agri-business community, and the regional government, to ensure success of the project, and integration to the community on several levels. The project is endorsed by Killam and District Business Development Association, Battle River Agri-Ventures Co-op, and the Town of Killam, among numerous additional supporters.

## **Advantages to Developing Countries**

NovaGreen can use multiple organic feedstocks. The proof of concept testing of our process was done with bagasse and aspen, but other feedstocks such as wheat straws, oat hulls and industrial hemp can be used with adjustments to the configurations in the steam explosion process. These changes or adjustments to use different feedstock are not costly or time consuming to implement.

## **Disadvantages to Developing Countries**

However, a key issue relating to grain based ethanol production is the negative impact of diverting grain from food and food chain purposes to the production of fuel. Using grain to produce fuel may contribute to food shortages, and/or increase prices for basic food chain feedstock.

## **Examples of Real Life Applications**

We are developing a greenhouse project in the Killam area, and the greenhouse will use NovaGreen EXL Refining outputs including Carbon Dioxide, Xylitol, and Lignin in the production of Food and Nutrition products. One additional component of the technology cluster that will contribute to long term viability of the NovaGreen technology hub, is the use of straw based biomass to provide both heat and energy to all NovaGreen facilities. We are working closely with two technology providers (both are active, proven, and very environmentally friendly) to provide the biomass combustors and turbines that will produce heat and electricity via biomass. This technology will initially link to the Food and Nutrition facilities, but will eventually play a role in all NovaGreen facilities, including the refining division.

## **Suppliers**

NovaGreen Inc.  
Alberta, Canada  
Email: [info@novagreen.ca](mailto:info@novagreen.ca)

## Tilby Separator<sup>132</sup> USA, Commercial

<b>Crop</b>	Rice, sugarcane
<b>Residue</b>	Rice Hulls and Sugarcane Waste
<b>Process</b>	Tilby process
<b>Equipment</b>	Dense Medium Separator
<b>Main Products</b>	Woody Fibers used as lumber materials

### Technical Description of Technology

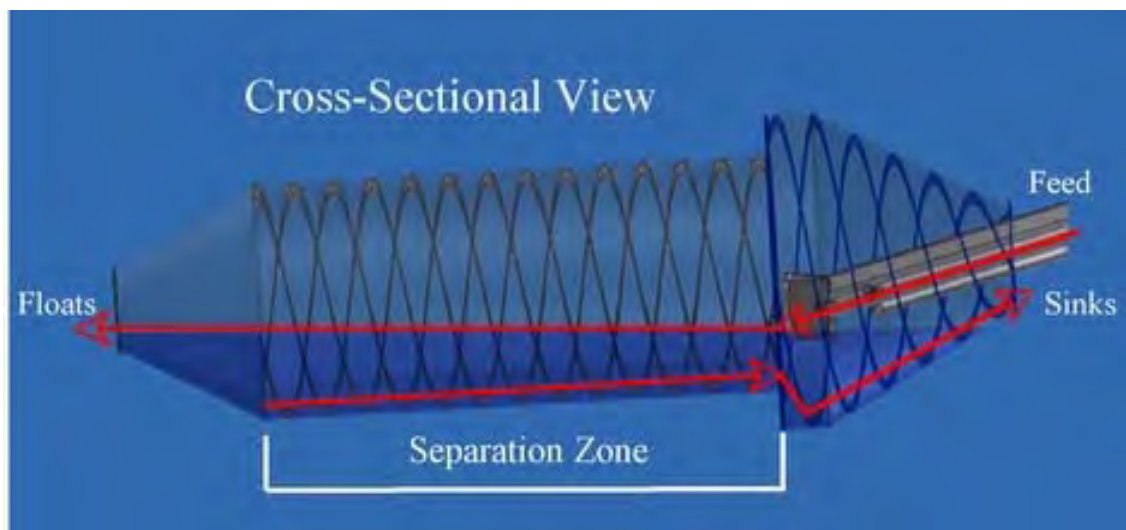

Here we find the dynamic of a quiescent bath where the density of water is changed by means of fine particles in suspension. At first glance, nothing could be simpler: one fraction floats, while the other fraction sinks. The length of the separation zone must be at least 2.2 times the diameter of the drum. Sinks are lifted up and out of the bath only when they are completely outside of the separation zone. Scrolls welded to the bottom of the bi-directional drum gently move the sinks in one direction, while the floats flow out on the surface of the bath in the opposite direction.

When the sinks exit the separation zone, they drop down underneath a curtain into an expanded drum and only at this point are they screwed up and out of the bath. Since there are no lifters and curtains within the separation zone, a bi-directional drum can be rotated at relatively high speeds without jeopardizing the accuracy of separation. The entire surface of the bath is available for separation and remains fully visible to the operator at all times.

<sup>132</sup> <http://www.esrint.com/Separation.html>



### **Detailed Process Description**<sup>133</sup>

Once the whole stalk or billet passes through a conventional mill press, not only is the structural integrity of the rind destroyed, but also the pith and rind become intimately mixed, and any possibility of economically separating them is destroyed. The inner core or pith of the sugarcane plant represents a biodegradable hemicellulosic fiber that has very little structural value, and if we are looking for alternatives to conventional forest products, even a small amount of pith in manufactured wood products would be quite undesirable. All attention, therefore, shifts to finding the means to separate rind from pith prior to the cutting and grinding of the sugarcane at the mill.

After all the inorganic material is removed from the billets, they are then routed to a very modern and sophisticated mechanical separator called the "Tilby Separator." The Tilby Separator consists of an initial set of rollers (a splitter station) where the billets are cut into two longitudinal halves. Afterwards, the process splits into a right and a left set of rollers (a depithing station), each set scraping out and separating the pith from the rind. The billets pass through the splitter and depithing stations at an extraordinary speed of 20 feet per second. Only the pith is routed to the juice extractor, while the rind is sent to a dryer. Once dried to a moisture content less than 2%, the rind can be fabricated into just about any type of engineered lumber imaginable.

Since the fiber structure and length of the original billet are fully preserved in the Tilby process, a lot less glue is required in the manufacture of engineered lumber than would ordinarily be the case. If fashioned into engineered wooden studs, we have all that would be needed to create the wall cavities of our proposed rice hull house. If fashioned into engineered-wood-product I-joists, we have all that we need to create floor and roof cavities. Sills, floor tiles, roof shakes, even the fiber needed in the manufacture fibercement siding, could all be made from the extremely robust fiber fibres of the sugarcane rind.

### **Operation and Maintenance Requirements**<sup>134</sup>

There are four factors that determine the loss of sugar with respect to billeted cane:

1. The number of harvester cuts (billet length),
2. The precision of the harvester cut (clean or frayed),
3. The forces applied to the billet (agitation/tumbling),
4. The amount of time the billet is subjected to these forces.

### **Environmental Considerations**

#### **Social Considerations**<sup>135</sup>

Since rice hulls require no shredding, hammer milling, fluffing, fiberizing, binding or stabilizing, they possess far less embodied energy than even cellulose insulation. Since rice hulls do not burn very easily, they require no

---

<sup>133</sup> [http://www.appropedia.org/Rice\\_Hulls\\_in\\_Construction](http://www.appropedia.org/Rice_Hulls_in_Construction)

<sup>134</sup> <http://www.esrint.com/sugar.html>

<sup>135</sup> [http://www.appropedia.org/Rice\\_Hulls\\_in\\_Construction](http://www.appropedia.org/Rice_Hulls_in_Construction)

flame or smolder retardants, and since they are so tough and durable, nothing prevents them from being used and recycled over and over again.

In choosing to build a structure derived in large measure from agricultural waste materials, not only do we do that which is right with respect to the environment, but we also fashion for ourselves a structure far superior to anything conventionally available. This super-insulated rice hull/sugarcane house, when correctly designed, should be considerably cheaper to build than a conventional structure, while continuously benefiting its owner with utility bills never exceeding on average more than one US dollar per day.

### **Operating Cost:**

Perhaps the most significant cost associated with the utilization of the rice hull is its transport. At a bulk density of about 9 lbs. per ft<sup>3</sup>, loose hulls can be transported at roughly the same cost as baled straw. However, to reduce the cost of transport, rice hulls can be compressed to as much as 25 lbs. per ft<sup>3</sup> without destroying their elasticity. They readily bounce back to their original density once the force of compression is removed.

### **Advantages to Developing Countries<sup>136</sup>**

Minimal source separation, with dense medium separation, allows us to recycle virtually all of the waste normally destined for landfill.

When the infrastructure needed to implement this strategy is well established, we should not be surprised to discover that it is far cheaper, even in the short term, to avoid landfill than to create it. A landfill is undoubtedly one of the worst things we can pass on to future generations.

### **Example of Real Life Applications**

<b>Level of Use</b>	Commercial Use
<b>Name of Project</b>	ESR International Dense Medium Separation
<b>Location</b>	Texas, USA

### **Suppliers**

#### **ESR International LLC**

4245 N Central Expy, Suite 590, Dallas, Texas 75205

#### **USA**

TEL: (214) 306 8740

FAX: (214) 520-0097

#### **Belgium**

TEL: 32 (51) 56 66 14

FAX: 32 (51) 56 66 14

---

<sup>136</sup> <http://www.esrint.com/index.html>



## Agriwaste CWT Thermal Conversion Process USA, Commercial

<b>Crop</b>	Agricultural Waste
<b>Process</b>	Thermal Conversion Process
<b>Equipment</b>	CWT Thermal Conversion Process
<b>Main Products</b>	Renewable Diesel, fertilizer and Special chemicals

### Technical Description of Technology:

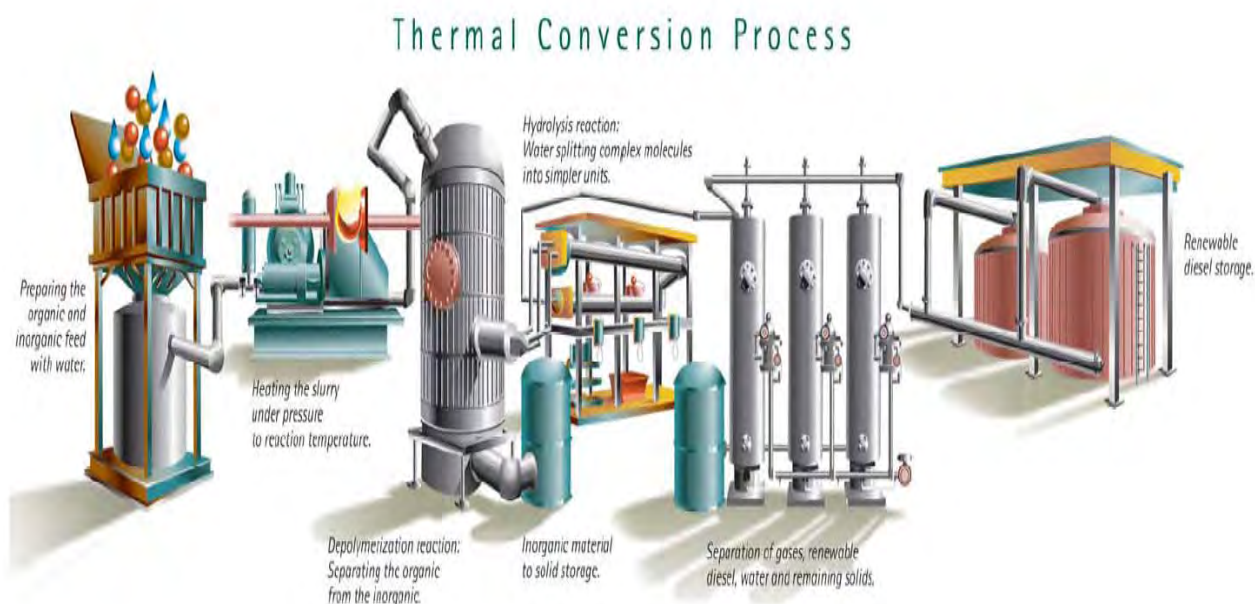

### Detailed Process Descriptions:

The Thermal Conversion Process, or TCP, mimics the earth's natural geothermal process by using water, heat and pressure to transform organic and inorganic wastes into oils, gases, carbons, metals and ash. Even heavy metals are transformed into harmless oxides.

### Main Products:

The TCP successfully converts fats, bones, greases, feathers and other wastes into renewable diesel, fertilizers, and specialty chemicals. TCP works with wet mixed feedstocks, and by cleverly utilizing water, avoids the energy penalty of drying the materials, typical of other technologies.

### Social Considerations

Agricultural wastes alone make up approximately 50% of the total yearly waste generation (6 billion tons) in the U.S. With TCP, the 6 billion tons of

agricultural waste could theoretically be converted into 4 billion barrels of oil. Realizing only a portion of this incremental domestic energy production is clearly in our national interest, because it ensures greater national energy independence. At the same time, this production provides a permanent solution to serious environmental problems caused by current waste disposal practices

### **Economic Instruments for Overcoming Barriers**

A variety of programs in the United States and abroad offer grants and financial incentives for the development and implementation of alternative sources of energy and waste reduction techniques. CWT has accessed some of these and is preparing appropriate documentation to qualify for many others, here and abroad.

However, corporate sponsorships and the enactment of joint ventures may be the most effective ways for CWT to be given the tools to generate a domestic, renewable source of fuel and wean the U.S. off its foreign oil addiction. Infrastructure security, particularly at large power stations, remains a critically urgent focus, and will be increased once general proposals and specific ideas are agreed upon by business leaders.

### **Advantages to Developing Countries**

Waste generated by agricultural food processors has traditionally been transported to rendering facilities where it is ground, processed, and dried to make animal feed, fertilizer, and other chemical products. In the past several years, there has been extensive concern about using processed animal matter as a feed supplement for animals that are destined for human consumption. The TCP, however, transforms these waste streams into renewable sources of oil to fuel our transportation, electricity, and heating requirements. In addition, the mineral residual from natural organic waste has the potential for fertilizer applications.

### **Examples of Real Life Applications**

Thermo Depolymerization Process, LLC (TDP) was formed in 1998 for the purpose of developing a demonstration facility for the then-fledgling TDP technology. Prior to 1998, several versions of the core technology had been designed and tested on various feedstocks. During the fourth quarter of 1999, a pilot plant was commissioned at the Naval Business Center in Philadelphia, PA.

### **Suppliers**

MagneGas Corporation  
U.S. 19 North #311  
Palm Harbor, Florida 34684

## BioTex BioReduction Machine<sup>137</sup> USA, Commercial

<b>Crop</b>	Corn, pineapple, rice, wheat, sugarcane, citrus
<b>Residue</b>	Corn cobs, pineapple plants, rice husks, fruit drops, wheat, sugar cane, citrus pumice and others.
<b>Process</b>	Reduction
<b>Equipment</b>	BioReduction Machine
<b>Main Product</b>	Ethanol, animal feed, industrial absorbents and additives for beverages

### Technical Description of Technology

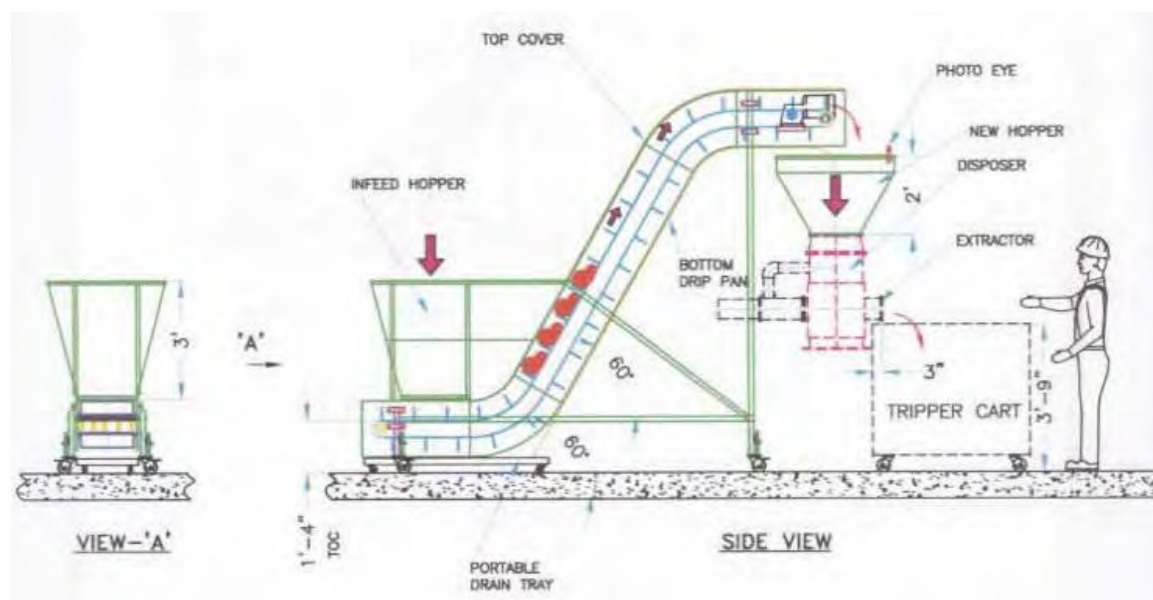

### Detailed Process Description<sup>138</sup>

The BioReduction machine, or BRT, can process raw biomass waste, such as corncobs, pineapple plants, rice husks, fruit drops, wheat, sugar cane, citrus pumice and others. These waste streams are fed into the machine either mechanically by hand, or automatically by conveyor system, and are ground into slurry so that the free water and other liquefied material can be extracted.

The output is in the form of two streams, the first being a nutrient-rich liquid that can be used in ethanol production, sold as fertilizer, or disposed of into the sewage system, depending on the composition and quantity of the feedstock being used. The second stream consists of the solid waste that has been mechanically dehydrated to more than 50% of its original weight and volume. It can then be sold as animal fodder, disposed of using traditional methods or further processed using other methodologies to derive

<sup>137</sup> <http://www.biotexcorp.com/technologies.html>

<sup>138</sup> [http://findarticles.com/p/articles/mi\\_pwwi/is\\_200701/ai\\_n17144046](http://findarticles.com/p/articles/mi_pwwi/is_200701/ai_n17144046)



downstream value-added products when a large enough stream can be produced.

### **Main Products**<sup>139</sup>

The raw materials created from the biomass extracts can be used to create Ethanol, animal feed, industrial absorbents and even additives for beverages.

### **Job Potential**

Currently have a total of five employees, all of whom are full time employees and dedicated to administration, engineering or sales.

### **Operation and Maintenance Requirements**

BioTex has built a pilot plant operation at its location in Vero Beach, FL. The pilot plant built costs approximately \$50,000, and was used to demonstrate BioTex's CST technology, as well as for producing samples of the company's value-added products.

### **Environmental Considerations**

#### **Social Considerations**

One drawback for renewable energy sector has been the cost of materials - this is where BioTex comes in. By taking the biomass waste and turning it into a low cost material, renewable energy companies can lower their production costs, use up unutilized feed stocks, reduce waste disposal costs and most importantly, help the environment.

### **Investment and Operating Cost**

The first plant in Vero Beach, Florida opened in the first quarter of 2006. This is a pilot plant and the cost of equipment is \$50,000.

### **GHG Emission Reduction Potential**

The technology process could have significant applications in the biomass waste-to-ethanol industry. This industry includes corn, stover, bagasse, citrus and other associated waste streams. The process allows converting solid waste into starch or cellulose and other consumable nutrients. Starch or cellulose could be employed as feedstock in ethanol plants producing ethanol. Given the optimal nature of the waste feedstock created by the technology, the productivity of the ethanol fermentation process can be significantly improved. The technology offers environmental benefits by utilizing waste materials that would otherwise be left in the fields contributing to carbon dioxide emissions.

---

<sup>139</sup> <http://www.hotstocked.com/8-k/btx-holdings-inc-BTXO-41063.html>

### **Advantages to Developing Countries**

BRT machines take up a small amount of floor space and companies that implement the BRT machine solely for waste reduction may see their waste costs reduced by more than 50% due to reduction of waste by more than 50% in volume

### **Example of Real Life Applications**

**Level of Use:** Commercial Use  
**Name of Project:** BioTex BioReduction Machine  
**Location:** USA

### **Supplier**

BTX Holdings, Inc.  
BioTex Corporation  
PO Box 191476  
Miami Beach, FL 33119-1476  
Phone: +1 (954) 776-6600  
Fax: +1 (954) 491-9200  
info@biotexcorp.com



## Bio-Enriched Method (Trichoderma and Azobacter) Philippines, Commercial

<b>Crop</b>	rice straws, weeds, sugarcane, bagasse, corn stalks and stovers, leguminous materials such as ipil-ipil, azolla, sesbania, mungbean, cowpea, soybean crop residues, and animal manure
<b>Residue</b>	
<b>Process</b>	Composting
<b>Equipment</b>	Incubator with fungus activator and N-fixing bacteria
<b>Main Product</b>	Organic Fertilizer
<b>By-Product</b>	N/A

### Technical Description of Technology

Employing both a fungus activator and a nitrogen-fixing bacteria, farm wastes are first decomposed by **Trichoderma sp.** for 2-3 weeks, after which the resulting compost is inoculated with live **N-fixing bacteria Azotobacter sp.** Incubation for 1 week produces a nitrogen-enriched compost that can supply a rice crop's total **N** requirement, depending on the material used, soil condition, and planting season.

### Detailed Description of the Technology

Mix all the rice straw, animal manure, and leguminous materials into 3:1 proportion.

Apply 2.5 kg of the fungus activator, known as BIO-QUICK, for every ton of composting material. Spread evenly on top of the first layer. Place 2-3 perforated bamboo poles horizontally across the first layer before adding the next layer. Make three layers.

Spread evenly 510 kg of Trichoderma fungal activator for every ton of composting material. Water each layer of compost heap until it is sufficiently moist. Cover with plastic sheet, used sacks, banana and coconut leaves to increase temperature and prevent too much water into the compost heap which could leach the nutrients.

Remove cover after 2-3 weeks or when the compost heap has decomposed. Separate under-composted materials for further composting. Spread evenly on top of each compost layer 2.5 kg of bacteria inocula, known as BIO-FIX, for every ton of compost material and incubate for 1 week. Cover the compost heap but do not allow to dry.

After 1 week of incubation of the bacteria inocula, the compost is ready for use. N content of the compost ranges from 1.5% to 3.0%. You need only apply 250-500 kg or 5-10 bags compost per hectare. Presence of live N-fixing bacteria in the compost will boost total N in the soil.

**Main Products:** Organic Fertilizer

**Operations and Maintenance Requirements:**

1. The decomposing compost heap can generate heat up to 60oC. Be careful in handling the compost while turning. Wear protective gloves or footwear so as not to scald your hands and feet.
2. Composting materials and microorganisms may cause allergies, although they are non pathogenic. To avoid inconvenience from itching, cover nose and mouth with mask; use long sleeved clothes, and wash body and hands after working on the compost.

**Social Considerations:**

There are currently 36 Mass Production Center (MPC) for fungal activators and 17 accredited by the Department of Science and Technology (DOST) to make these activators available to farmers. These centers include government, non-government organizations, and cooperatives. There are 15 similar agencies producing both fungal activators and ready-to-use compost.

BIOTECH and IBS also provide training for cooperatives and entrepreneurs who wish to go into commercial organic fertilizer and mass production of these microorganisms.

**Advantages to Developing Countries**

The Philippines is basically an agricultural country. Most of the populations live in rural areas, and agriculture employs about 50% of the total work force. A large amount of chemical fertilizers are used: 1.4 million mt in 1995. Of this, 37% was urea, half of which was imported. In 1995, the Philippines exported around 700,000 mt of chemical fertilizer and imported about 1,237 thousand mt, about half of which was urea. More than half the chemical fertilizer applied in the Philippines (52%) is used for rice and corn.

Organic fertilizer production began in 1974, but in 1978 organic fertilizers were less than 1% of total fertilizer sales, rising to 1.34% in 1992. As of 1993, there were 26 licensed manufacturers of organic fertilizers, and 15 processors of guano phosphate, phosphate rock, and soil conditioners (PCARRD info sheet 1996). These figures may have increased by 1996, since a number of producers of compost who use the Rapid Composting Technology have obtained licenses from the Fertilizer and Pesticide Authority (FPA).

**Benefits of Compost**

- Big savings, increased farmer self-reliance.

- Increases yield.
- Improves water-holding capacity of the soil.
- Improves aeration.
- Provides humus or organic matter, vitamins, hormones and plant enzymes which are not supplied by chemical fertilizers.
- Acts as buffer to changes in soil pH.
- Kills pathogenic organisms, weeds, and other unwanted seeds when a temperature of over 60°C is reached.
- Mature compost quickly comes into equilibrium with the soil.
- Different materials can be blended or mixed together which can increase the nutrient content of the compost fertilizer

### **Examples of Real Life Applications**

**Country:** Philippines

**Level of Use:** Commercial

### **Suppliers**

Philippines' Department of Agriculture,  
Regional Field Unit No. 10,  
Cagayan de Oro City - Northern Mindanao

## Paper from pulp<sup>140</sup> USA and China, Commercial

<b>Crop</b>	Sugarcane
<b>Residue</b>	Bagasse
<b>Process</b>	Paper-making
<b>Equipment</b>	Paper-making machine
<b>Main Products</b>	Paper
<b>By Products</b>	Paper wares like cups, bowls, plates, three compartment box

### Detailed Process Description

The method of making paper is essentially a simple one—mix up vegetable fibers, and cook them in hot water until the fibers are soft but not dissolved. The hot water also contains a base chemical such as lye, which softens the fibers as they are cooking. Then, pass a screen-like material through the mixture, let the water drip off and/or evaporate, and then squeeze or blot out additional water. A layer of paper is left behind. Essential to the process are the fibers, which are never totally destroyed, and, when mixed and softened, form an interlaced pattern within the paper itself. Modern papermaking methods, although significantly more complicated than the older ways, are developmental improvements rather than entirely new methods of making paper.

Probably half of the fiber used for paper today comes from wood that has been purposely harvested. The remaining material comes from wood fiber from sawmills, recycled **newsprint**, some vegetable matter, and recycled cloth. Coniferous trees, such as spruce and fir, used to be preferred for papermaking because the cellulose fibers in the pulp of these species are longer, therefore making for stronger paper. These trees are called "softwood" by the paper industry. Deciduous trees (leafy trees such as poplar and elm) are called "hardwood." Because of increasing demand for paper, and improvements in pulp processing technology, almost any species of tree can now be harvested for paper.

Some plants other than trees are suitable for paper-making. In areas without significant forests, bamboo has been used for paper pulp, as has straw and sugarcane.

- See illustrations below

---

<sup>140</sup> <http://www.madehow.com/Volume-2/Paper.html>

## **Environmental Considerations<sup>141</sup>**

Compared to virgin paper manufacturing, making paper from recycled material reduces climate-changing gas emissions, requires less energy, lowers air pollution, and effluent flows, and conserves landfill space. 30 percent post-consumer recycled content copier paper is the norm in many State offices. Some organizations are going farther by switching to 100 percent post-consumer recycled content processed chlorine-free copier paper, which is made entirely from paper that has been used by consumers and then collected through recycling programs.

- Thirty (30) percent post-consumer recycled content copier paper contains 70 percent virgin tree fiber. According to estimates from paper industry experts, making that paper requires one tree for every two and a half cases of paper, however, making 100 percent post-consumer recycled content paper requires no new trees to be harvested.

Saving trees and habitats isn't the only benefit. Producing 100 percent instead of 30 percent post-consumer recycled content office paper reduces climate-changing gas emissions by about 30 percent, requires 35 percent less energy, and reduces effluent discharges by more than 40 percent.

Additional benefits come from choosing paper made with less or no chlorine. Bleaching (whitening) paper pulp with elemental chlorine or chlorine compounds produces chlorinated pollutants, such as dioxin, in the wastewater stream. According to the United States Environmental Protection Agency, dioxin "is a toxic industrial pollutant that is ... persistent in the environment. It accumulates in the fat tissue of animals and humans and has been linked to adverse human health effects, including cancer and toxicity to reproductive, immunologic, and endocrine systems." Totally chlorine-free bleaching, which uses alternative bleaching agents, such as oxygen and peroxide, eliminates dioxins and other chlorinated pollutants from the wastewater stream. In order to reduce potential risks, a number of paper manufacturers are switching to chlorine-free technologies.

## **Examples of Real Life Applications**

Commercial Use Paper from sugarcane pulp USA and CHINA

### **Suppliers<sup>142</sup>**

Pulsar Products

2570 Superior Avenue, Cleveland, Ohio 44114

ecvv.com<sup>143</sup>

internet shopping: <http://www.ecvv.com/>

World Centric<sup>144</sup>

2121 Staunton Ct, Palo Alto, CA 94306

---

<sup>141</sup> <http://www.green.ca.gov/EPP/Paper/Copier/background.htm>

<sup>142</sup> <http://www.pulsarpaper.com/>

<sup>143</sup> <http://www.ecvv.com/>

<sup>144</sup> <http://www.worldcentric.org/about/contact.htm>

Alibaba.com<sup>145</sup>  
internet shopping

august Art Craft<sup>146</sup>  
internet shopping

Biodegradablestore.com<sup>147</sup>  
internet shopping

148

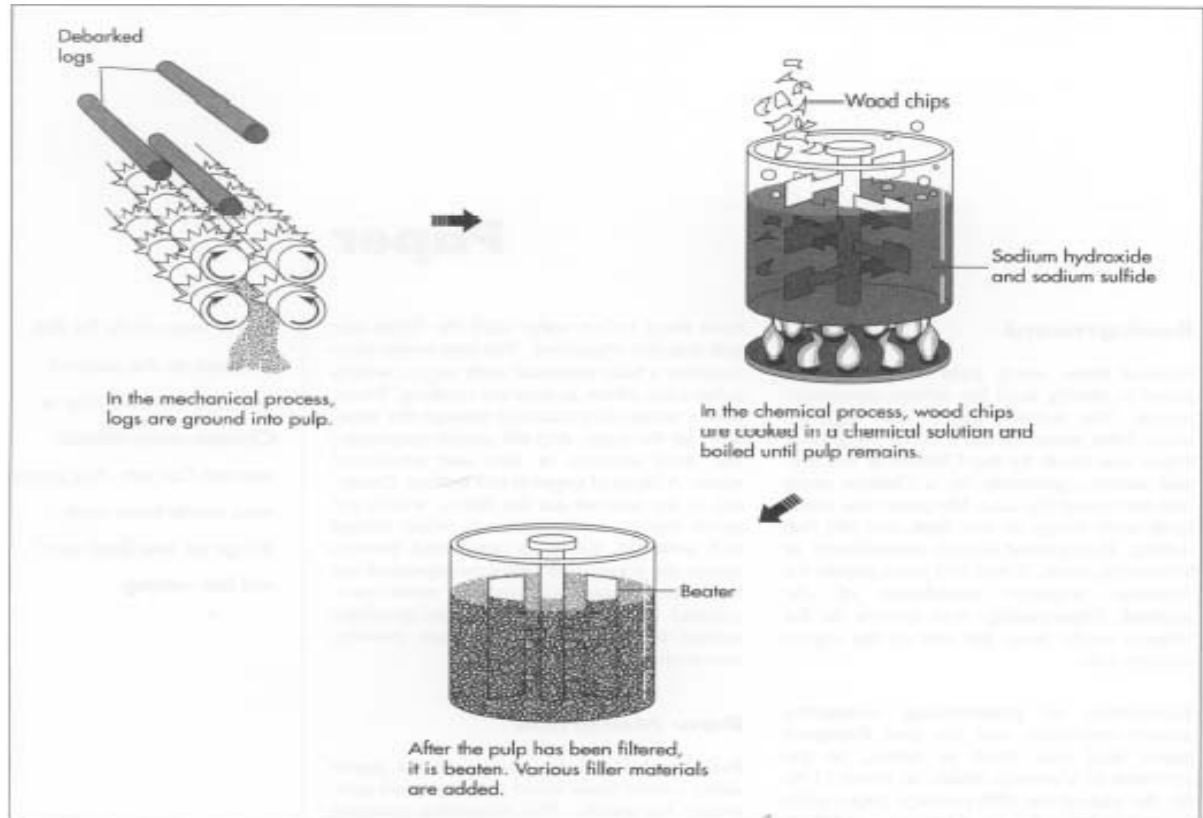

<sup>145</sup> <http://www.alibaba.com/>

<sup>146</sup> <http://www.augustartpaper.com/>

<sup>147</sup> <http://www.biodegradablestore.com/index.html>

<sup>148</sup> <http://www.madehow.com/Volume-2/Paper.html>

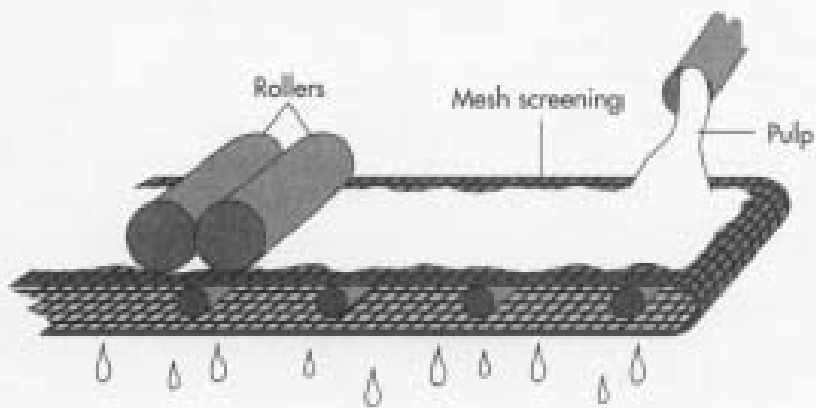

The beaten pulp is fed onto a moving belt of fine mesh screening. The pulp is squeezed through a series of rollers to remove the water.

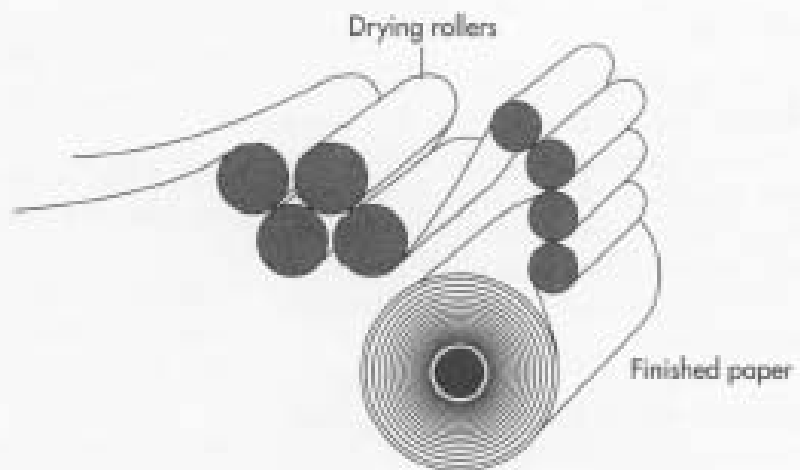

The paper passes over a series of steam-heated cylinders to remove the remaining water. The dried paper is then wound onto large reels.

## Kinsei Seishi Recycling Technology<sup>149</sup> Japan, Commercial

<b>Crop</b>	Sugarcane, Kenaf
<b>Residue</b>	Bagasse and kenaf pulp
<b>Auxiliary materials</b>	Flakes of recycled pet bottles
<b>Process</b>	Hot melt process
<b>Equipment</b>	Fiber blender, roller, high pressure water jet
<b>Main Products</b>	Paper and packaging materials

### Detailed Process Description:

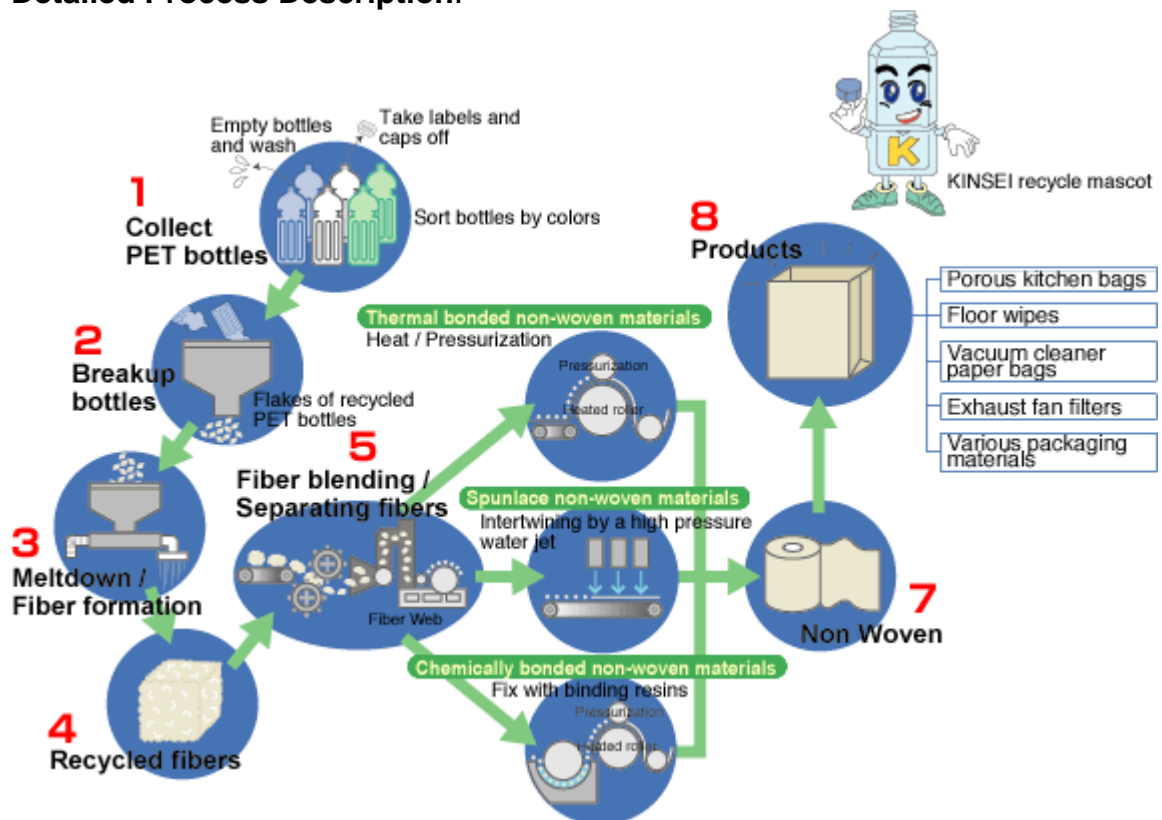

<sup>149</sup> <http://www.kinseiseishi.co.jp/english/recycle02.html>



**Biodegradable  
fiber materials**



**1  
Non Woven**



**2  
Product**



Porous kitchen bags

Various packaging materials

Various sheets

Carbon dioxide

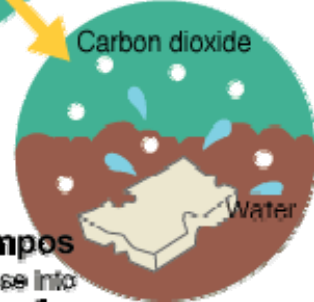

**Decompos**

Once it is buried in the soil, it will decompose into carbon dioxide and water in about three months.

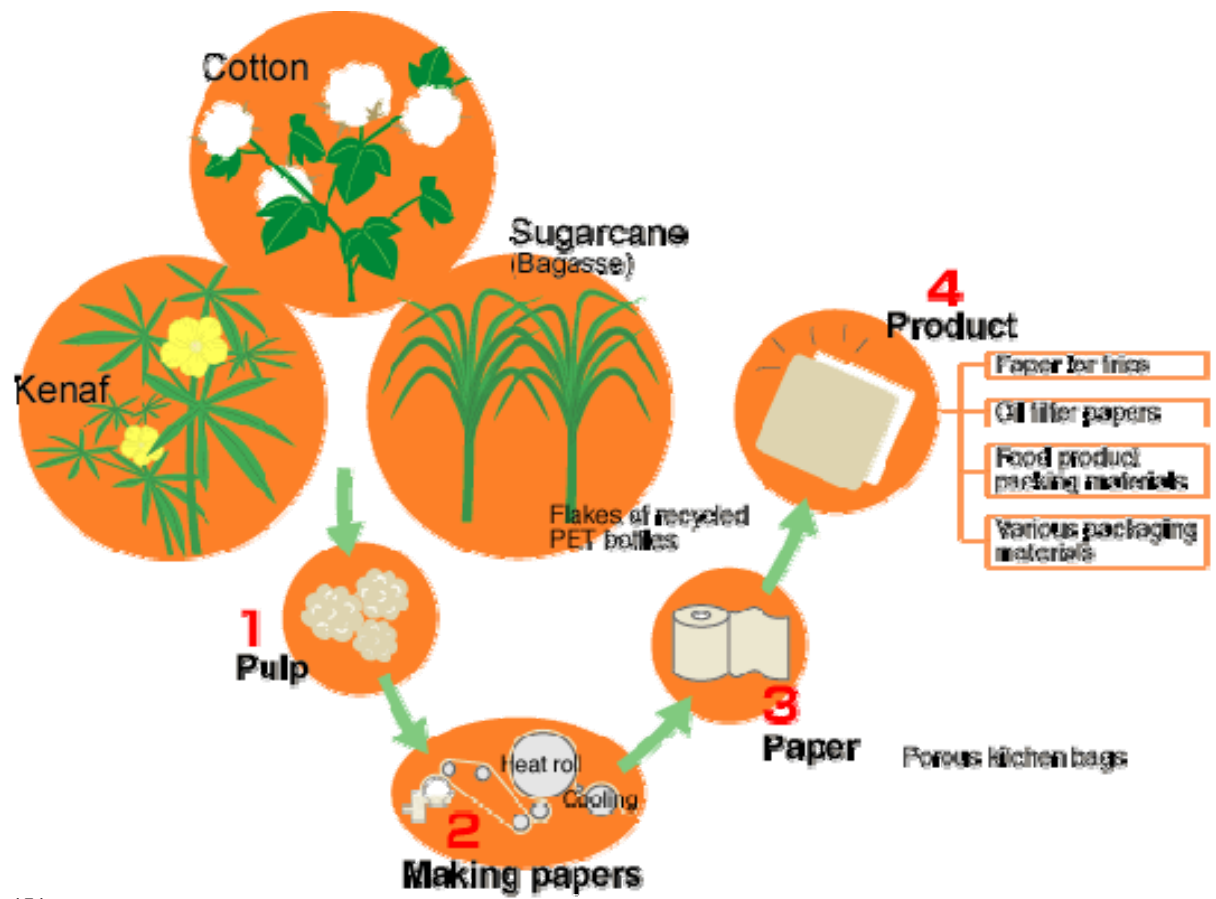

151

<sup>151</sup> <http://www.kinseiseishi.co.jp/english/recycle04.html>

Type of non-woven materials	Method of binding fibers	Use
Chemically Bonded Non-Woven Materials (Card system)	Bonding fiber web with chemical binders (adhesive agents)	Tray mats, Food freshness maintaining sheets, Air-conditioning filters, Oil filters
Thermal Bond Non-Woven Materials	Heating thermal adhesive fibers to bind fiber web	Porous kitchen bags, Food packaging materials, Tea bags (Green / Black tea), Hygienic materials (Nappies, Napkins)
Spunlace Non-Woven Materials	Binding fiber web with high pressure water jet	Tea bags (Green / Black tea), Various wipes, Medical gauze, Food freshness maintaining sheets
Air Laid Non-Woven Materials (ECO-PAL) (Air Laid System)	Making sheets by dispersing thermal adhesive fibers, pulp and others into the air, then binding them by heat <a href="#">Please refer to this section for features of Air Laid Non-Woven Materials</a>	Various filters, Food freshness maintaining sheets, Oil adsorbents, Various wipes
Wet type Non-Woven Materials	Binding pulp with hydrogen or thermal adhesive fibers by heat	Coffee filters, Oil filters, Paper for fries, Food freshness maintaining sheets

- It is possible to combine various non-woven materials during manufacturing process  
Examples: Air Laid and Spunbond or Meltblown, Air Laid and Chemical Bonding, Thermal Bond and Spunbond
- Our associated companies can combine non-woven materials by a Hot-melt process using polyethylene and rubber adhesive agents.
- We can also add colors and patterns on non-woven materials by coloring machines and Flexographic printing machines

<sup>152</sup> <http://www.kinseiseishi.co.jp/english/nonwoven.html>

## **By Products**

Tray mats, Food freshness maintaining sheets, Air-conditioning filters, Oil filters

Porous kitchen bags, Food packaging materials, Tea bags (Green / Black tea), Hygienic materials (Nappies, Napkins)

Tea bags (Green / Black tea), Various wipes, Medical gauze, Food freshness maintaining sheets

Various filters, Food freshness maintaining sheets, Oil adsorbents, Various wipes

Coffee filters, Oil filters, Paper for fries, Food freshness maintaining sheets

**Job Potential:** Additional income for farmers

## **Environmental Considerations:**<sup>153</sup>

(5) From “Disposable” to “Recyclable”

KINSEI SEISHI is promoting the recycling of PET bottles. Our aim is to recycle 1,200 tons per year (20 million PET bottles) by making products from them.

Eco Bonn Rick is a porous kitchen bag made from recycled PET bottles. It is a non-woven material which consists of fine intertwined fibers. It filters fine impurities thereby helping us to return environmentally friendly water back to rivers and oceans.

Example of Real-life Applications:

**Level of Use**            Commercial Use

**Name of Project**    Non-woven Materials from bagasse and kenaf pulp

**Location**             Japan

## **Supplier:**

KINSEI SEISHI CO., LTD.

63 Iguchi-cho, Kochi-shi,

Kochi-ken 780-0921

---

<sup>153</sup> <http://www.kinseiseishi.co.jp/english/recycle.html>

## Bale as feedstock USA, Commercial

<b>Crop</b>	Alfalfa
<b>Residue</b>	Leaves and stems
<b>Process</b>	Bale silage
<b>Equipment</b>	Baler, bale wrapping machine
<b>Main Product</b>	feedstock

### Detailed Process Description<sup>154</sup>

**Mowing** with a mower-conditioner is best. The mowed forage is left in the swath long enough for it to wilt to 55-65 percent moisture. Drying periods usually range from two to three hours if mowing is done early in the day, to overnight if mowing is done late in the day.

**Baling** with a fixed-chamber baler makes uniform sized bales which fit easily into bags or stack neatly when wrapped. Some balers will require modifications such as scrapers to prevent gum buildup on belt rollers, or shields to prevent wrapping of the crop. A slow ground speed helps make tight bales which are less likely to spoil. Net tying and plastic twine are recommended; sisal twine should be avoided because the chemical twine preservatives often degrade the plastic used as a bale wrapper. Inoculants can be added, but usually are not necessary. Hauling the bales to a bagging or wrapping site immediately helps ensure feed quality, as well as bale roundness which is important when wrapping.

**Wrapping** bales is quicker than bagging, but it requires a bale wrapping machine, which means a capital expenditure you don't have with bagging. **Bagging** is trickier than wrapping. After a few bales are made, check the bag fit. Bag at the storage site only because this area should already be cleared of obstacles and nuisances that puncture the bags. Once the bag is over the bale, push out excess air before sealing. To seal the bag, a strong hand is needed to twist and stretch the bag end while the second hand or a second person ties a knot with a rope. Twist tightly and tie once, then bend the twisted plastic back onto itself and tie the two twists together. Patch holes found in a bale bag as soon as possible because wind causes loose plastic to bellow and provide an air exchange which usually spoils most of the outer layer of the bale. Use polyethylene tape.

### Job Potential

- Benefits the small or part-time farmers in particular
- One person can complete the steps involved in making round bale silage if adequate equipment is available

---

<sup>154</sup> <http://cropsoil.psu.edu/Extension/Facts/agfact9.pdf>

## Parameters for Procurement Specifications<sup>155</sup>

### **BALE HANDLING EQUIPMENT**

There are numerous bale handling devices to move or transport the bagged or wrapped bales, with new ones being introduced regularly from other countries. Most seem to have the following design characteristics.

1. Spears, either mounted on a front-end loader or on a three-point hitch
2. Twin moveable forks with rollers which slide under and cradle the bale
3. Disks which clamp and squeeze the bale while lifting
4. Grapples with overhead arms
5. Trailer mounted sleds which slide under bales

Regardless of the design, each requires at least a 50 hp tractor in order to safely move the bales.

## Operation and Maintenance Requirements<sup>156</sup>

### **BALE STORAGE**

The storage site will give better results if stubble and sharp objects are cleared. Some people lay an old piece of plastic on the ground prior to placing the bales. Spray the perimeter of the stack to kill weeds which harbor insects and rodents. Do *not* cover the bales with an extra layer of plastic because it makes an ideal nesting site for rodents. Rodents can chew through the plastic wrap or bag and greatly increase storage losses. Find a shady area, preferably on a north facing slope, to avoid temperature fluctuations which can degrade both the silage as well as the plastic.

To increase bale density in storage, consider stacking the bales as follows:

1. Above 75 percent moisture content, use a single-layer stack.
2. Between 65 and 75 percent moisture, use a double-layer stack, pyramid fashion.
3. Below 65 percent moisture content, stack up to three layers high, pyramid fashion.

### **BALE FEEDING**

Feeding round bales of silage is similar to feeding large round bales of hay when conventional bale feeding rings can be used. With the high investment for wrapping bales, it is essential to control feeding losses. Some studies have shown up to 50 percent loss when large round silage bales are simply unrolled on the ground. This loss can be reduced to less than 10 percent by using a simple ring feeder. Mobile feed carts, especially designed for unrolling or grinding large bales within narrow barn alleys, are now available in the United States. Tub grinders can be used, but plugging of the grinder with the large bales of silage may be a concern.

The feed quality of large round bale silage, especially those bales with a high proportion of legumes, may cause overfeeding to some classes of animals. Consider using the bales with high proportion of legume for classes of animals that require high quality forage, and restricting the amount of bales available at any time.

---

<sup>155</sup> <http://cropsoil.psu.edu/Extension/Facts/agfact9.pdf>

<sup>156</sup> <http://cropsoil.psu.edu/Extension/Facts/agfact9.pdf>

**Price of Machine** : refer to the table below for the ff. items

### Manpower Cost<sup>157</sup>

Table 1. Comparative costs of wrapping versus bagging for two typical circumstances.

		– 300 bales/year –		– 150 bales/year –	
<b>Inputs</b>		<b>Wrap</b>	<b>Bag</b>	<b>Wrap</b>	<b>Bag</b>
Plastic	Price \$/bale	3.50	7.00	3.50	7.00
Labor	No. workers	2	3	2	3
	Bales/hour	25	20	20	16
	Wage \$/hour	6.00	6.00	6.00	6.00
Machine	Price \$	6,000	5,000	6,000	2,000
	Interest %/year	10	10	10	10
	Life Bales	4,000	5,000	4,000	5,000
	Salvage value %	20	20	20	20
Size	Bale weight lb DM	600	600	600	600
<b>Results</b>					
Plastic cost	\$/bale	3.50	7.00	3.50	7.00
	\$/ton	11.67	23.33	11.67	23.33
Labor cost	\$/bale	0.48	0.90	0.60	1.13
	\$/ton	1.60	3.00	2.00	3.75
Machine cost	\$/year	787.23	602.66	641.03	206.96
	\$/bale	2.62	2.01	4.27	1.38
	\$/ton	8.75	6.70	14.25	4.60
<b>Total cost</b>	\$/bale	6.60	9.91	8.37	9.50
	\$/ton DM	22.01	33.03	27.91	31.68

Source: D.R. Buckmaster, 1991, unpublished data.

### Advantages to Developing Countries

Could create employment in the rural areas

### Example of Real Life Applications

**Level of Use** Commercial Use  
**Name of Project** Making round bale silage  
**Location** USA

### Suppliers

John Wenzel<sup>158</sup>  
 913-773-8110 30169 251 street  
 Easton Kansas, 66020 Leavenworth County  
 Two Hawk Ranch<sup>159</sup>  
 HCR 37 Box 1181  
 Sandy Valley, NV 89019

<sup>157</sup> <http://cropsoil.psu.edu/Extension/Facts/agfact9.pdf>

<sup>158</sup> <http://www.cowbones.com/>

<sup>159</sup> <http://www.twohawkhayranch.com/>

## **Clothes from Banana Japan, Commercial**

<b>Crop</b>	Banana
<b>Residue</b>	Banana Stalk
<b>Process</b>	Extraction
<b>Equipment</b>	Spinning wheel
<b>Main Product</b>	Fibers
<b>By products</b>	Clothes

### **Technical Description of Technology**

The banana is grown, the fiber taken, the thread spun, dyed, woven. Two hundred banana trees are needed for one roll of kimono cloth. They say that to get good fiber you need good trees, so the healthy cultivation of the fiber-bananas is a crucial first stage. Adding fertilizer and trimming the plants of dead leaves and wicks is a part of the job and it's not unusual for the whole workshop to go out into the fields to tend the banana trees for a day. And it's another hard process to get them into fibers. Take off the outer skin, boil in a big pot, and many other fiddly processes - the preparations take much longer than the weaving.

### **Detailed Description Process**

#### **Kijoka Banana Fiber Cloth**

The making of one of these banana fiber cloths is long and much is needed to be done before weaving can actually take place. The whole process begins with the cultivation of the banana plant from which the fiber is obtained by cutting stems and processing them. The fiber is then dyed and is finally ready for weaving.

1. Cultivation: Leafs are cut and shoots taken out of the banana plant two or three times a year to make sure the fiber is soft. Mature stems are cut and the skin is peeled off. The outer fiber is coarse and is used for tablecloths. The next layer of fiber is used for obi and ties. The next layer of fiber is called the nahaguu and is used for kimono.





2. Cooking the Fiber: A rope is laid in the bottom of a big pot of boiling lye--an alkali solution. The separated fiber is bundled and put in the solution and cooked for several hours with the lid on. The alkalinity of the lye is critical. After boiling, the fiber is washed to remove the alkali.



3. Rolling up: Next the fiber must be paired from the skin. First the skin is separated lengthwise into two or three flat strips and separated with a bamboo tool. The soft fiber is used for the weft and the hard or colored fiber is used for the warp. Having dried the fiber in the shade it is rolled up.



4. Yarn: A thread is now 'spun' from the fiber. First, the fiber is put in water and lightly squeezed. Next, it is separated by running the nails or tips of the fingers along between the fibers from the root upwards. The thickness of the thread depends on what is going to be woven. If it is for a kimono cloth then it is made very fine. The individual fibers are joined together to make a continuous thread, which is drawn to stop it separating. The ends of the thread where joined are cut short. This work is very time consuming and requires much patience.



5. Twisting: In order to make the warp and weft ikat or kasuri threads more robust and to prevent napping, they are twisted up on a spinning wheel, while being moistened with a spray. If the twist is too loose the thread will nap and make weaving difficult. If, on the other hand, the thread is twisted too tightly it becomes difficult to beat and much more

difficult to match up the kasuri pattern. The required length of thread for the warp is also measured.



6. Binding: Thread is stretched out and using a template those parts of the thread that do not need to be dyed are bound with the skin of the banana plant, and once again bound tightly with a cord. It is a job requiring a great deal of experience because if the binding is too tight the thread will break and if it is too loose the dye will seep under the binding.



7. Dyeing: The two main dyes used are sharinbai( *Rhaphiolepis umbellata*) and Ryukyu indigo. To extract a dye from sharinbai thick branches and twigs are cut up small and put into a large pot of water and boiled. The kasuri threads are immersed in this dye and then partially dried. The thread is sometimes steamed and the dyeing process is repeated until achieving the required color. The thread is usually dipped a minimum of 30 times.



8. Setting Up: After removing the binding, the thread is laid out following the design and passed through a temporary reed. The warp is then carefully wound onto the beam and passed through the reed and heddle



9. Weaving: Water is sprayed on the thread as it is being woven because if it becomes dry the thread will break. It is best, therefore, to weave this cloth during the rainy season in May and June.



10. Washing: When a bolt of cloth has been woven it is washed. Then it is put in an alkali solution and boiled. Afterward it is washed and dried. It is then neutralized by immersing it in a rice vinegar made from fermenting a rice gruel and rice flour. After two hours the cloth is removed, washed and partially dried. The cloth is then stretched and straightened by hand and finally ironed.



### **Advantages to Developing Countries**

Woven from fibers taken from the banana tree, banana fiber cloth is highly representative of the weaving of Okinawa. It was very popular for making a piece of summer-weight formal dress called kamishimo in the Edo period (1600-1868) and being light and comfortable to wear, it is still a great favorite with many people today for kimono in the height of summer. But kimono are not its only use. Some is made into obi, while other pieces make fine cushion covers. Ties, bags and table centers are also made of this engaging cloth, which also makes fine split curtains or noren. There are 52 people employed by the 27 firms producing one of Okinawa's finest cloths.

**Example of Real Life Applications**

Country: Japan

Level of use: Commercial

**Suppliers:**

Cooperative Union

Kijoka Banana Fiber Cloth Association

1103 Kijoka, Ogimi-son,

Kunigami-gun, Okinawa Prefecture

tel 0980-44-3202

**Sources:**

1. <http://www.kougei.or.jp/english/crafts/0130/f0130.html>

## Decorticating Machine and Motorised Ratt India, Commercial

<b>Crop</b>	Coconut
<b>Residue</b>	Husk
<b>Process</b>	Fiber extraction
<b>Equipment</b>	Decorticating Machine
<b>Main Product</b>	Rope and twine, brooms and brushes, doormats, rugs, mattresses and upholstery, often in rubberized coir pads. <sup>160</sup>

### Technical Description of Technology<sup>161</sup>

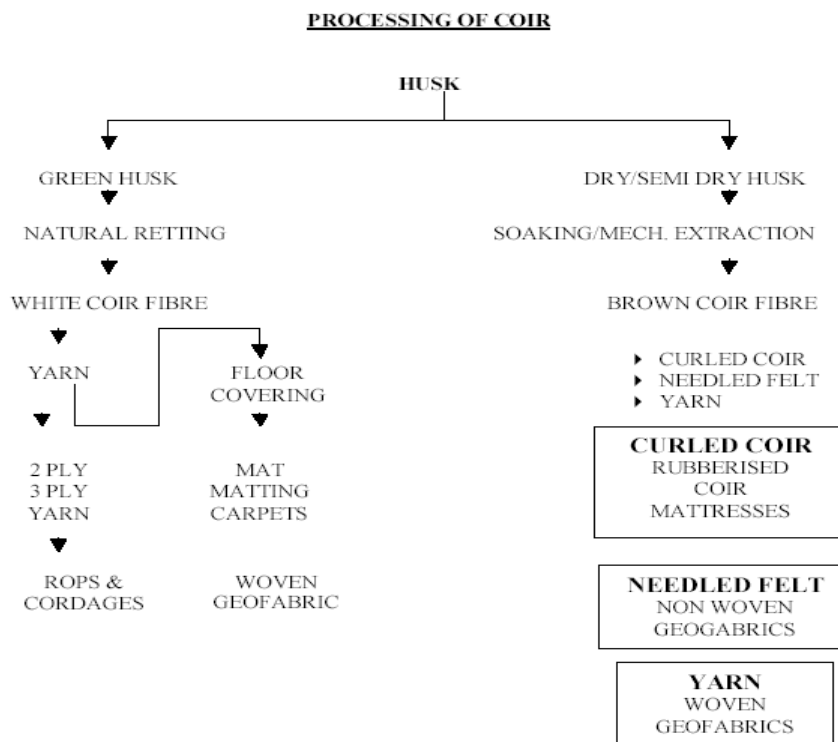

### Detailed Process Description<sup>162</sup>

#### Traditional fibre extraction

The traditional production of fibres from the husks is a laborious and time-consuming process. After separating of the nut, the husks are processed by various retting techniques generally in ponds of brackish waters (for three to six months) or in backwaters or lagoons. This requires 10-12 months of anaerobic (bacterial) fermentation. By retting, the husks are softened and can

<sup>160</sup> <http://coirboard.nic.in/coirtrade.htm>

<sup>161</sup> <http://www.ncrmi.org/husk.pdf>

<sup>162</sup> [http://coirboard.nic.in/about\\_process.htm](http://coirboard.nic.in/about_process.htm)

be decorticated and the fibre is extracted by beating, which is usually done by hand. After hackling, washing and drying (in the shade) the fibres are loosened manually and cleaned. The remaining residual pith - which was previously considered a waste problem - has recently found new profitable markets as a peat moss substitute for horticultural production.

Traditional practices of this kind yield the highest quality of (white) fibre for spinning and weaving. Retted fibres from green husks are the most suitable fibres for dyeing and bleaching. For the production of more coarse brown yarns shorter periods of retting may be applied. These find an increasing outlet in geo-textile applications.

### **Mechanical Extraction**

Alternatively, mechanical processes using either de-fibering or decortivating equipment process the husks after only five days of immersion in water tanks. Crushing the husk in a breaker opens the fibres. By using revolving "drums" the coarse long fibres are separated from the short woody parts and the pith. The stronger fibres are washed, cleaned, dried, hackled and combed.

### **Green decortication and Microbial treatments**

New environmentally friendly methods for fibre production are of interest. These can be locally exploited on relative small-scale, and have the potential to produce a more constant quality of fibres. Novel developments by the Central Coir Research Institute, under Coir Board, using a bio-technological approach with specific microbial enzymes have reduced the retting time substantially to three to five days. High quality fibre production has been maintained.

Similar protocols can be developed to enhance the properties of the fibres in regard to surface properties such as smoothness and porosity. By using specific (microbial) lignolytic enzymes (laccase/phenoloxidase), the fibre surface can be bleached (or activated to react more easily with the dyes).

## **Hand Spinning**

The usual practice in hand spinning is to roll the fibre into short length of 6 to 9 inches, giving a clock-wise twist by hands. When a sufficient quantity has been made, two of these short lengths are taken in hand together and made into yarn of two plies by giving a counter twist, using both palms.

When the counter twist reaches near the end of the striking, further pieces of short lengths kept ready are added one after other, while the counter twist by hand is continued till the required length of yarn for a knot is reached. This is reeled in the form of a hank and a knot is made at the end. Handspun yarn always has a soft twist.

**Traditional Ratt Spinning** Spinning is usually done on the 'Charka' or spinning wheel. Wheel spinning is gradually displacing hand spinning.

From the middle of the 19th century, coir spinning wheels have been introduced with a view to increasing production and obtaining the hard twist required for the manufacture of matting, etc.

To prepare two-ply coir yarn on the spinning wheel, one set of two wheels, one stationary and the other movable is required. The stationary wheel

usually contains two spindles set in motion through the centre of the wheel. The movable wheel contains one spindle only. Two persons take the silvers of 'coir' prepared and kept ready after willowing.

Usually women keeps them in their arm pits, make a loop with a small quantity of fibre and then puts the loop thus formed into the notch of one of the spindles on the stationary wheel and gives the fibre a uniform thickness while walking backward. Another operator then gives the twist to the fibre thus led by turning the handle of the spinning wheel. This operation is continued till the required length of strand is reached. The strands are then passed through a grooved rod and tied together into the notch of the spindle, the grooved rod being allowed to move forward. The movable wheel is turned in the opposite direction.

The object of the grooved rod is to regulate the twist of the yarn and to prevent entanglement of the strands at the time of doubling. When the grooved rod reaches the stationary wheel, the turning of the spindles of the spinning wheel is stopped and all the ends from that of the stationary wheel are cut off and the yarn is tested to see whether there is sufficient twist. If more twist is required, the movable wheel is turned toward its original direction till the required twist is obtained, if it contains more twist than desired, the movable wheel is turned in a direction contrary to the original twist. Traditional Wheel spinning using a spinning wheel requires three people, who may produce 12-15 kg of yarn per day.

### **Motorised Traditional Ratt**

Motorised Traditional Ratt is a developed form of a coir spinning 'charka'. Here, the stationary ratt is rotated using a suitable contrivance attached to an electric motor. By attaching the rotating system to the stationary ratt one worker is avoided and the productivity is increased. The wages thus earned are divided among the two workers resulting in enhancement of wages of spinners. This system has been introduced recently and found successful in the industry for spinning all varieties of yarn.

### **Motorised Ratt**

The research and development in coir industry was mainly aimed for reducing the drudgery of the workers involved in the spinning of coir yarn on traditional and motorised traditional ratts. Two or three spinners are engaged for exercising the production activity in yarn spinning where they are exposed to changing weather conditions, which ultimately affects the production. They are also forced to walk up and down in the spinning yard for taking the individual strands and for doubling operation.

It was a long time dream of the coir industry to introduce a contrivance for reducing the drudgery of the labourer and improve the productivity and also enhance the earnings of the workers engaged in the spinning. As a result of research and development, a spinning device for attaining the real goals of reducing the drudgery, improving the productivity and to improve the working environment, the motorised ratt was introduced in the industry.

In the case of a motorised ratt the spinner is made to sit on a chair /stool and roll the well cleaned fibre stacked in the spinning trays attached to the spinning device where the yarn is spun and wound over the bobbins attached to the ratt.

The simple device is now popular in the industry and the benefit of the device has been extended to all spinning areas, all over India. Coir board has taken all efforts to popularise this spinning device and a scheme has been evolved under 'Mahila Coir Yojana Scheme' for providing motorised ratt to spinners at a subsidised rate. The introduction of the motorised ratt in the industry has paved way for increasing the employment opportunity, as the new generation has taken up the spinning activity in the coir sector as the change in the working environment. All varieties of coir yarn in the industry are produced on ratt with a slight alteration on the equipment.

**Automatic Spinning** The production turnover in the case of hand spinning was less. The efforts to maximise the productivity of the yarn resulted in the introduction of automatic spinning machine units.

The automatic spinning machine units are capable of production of yarns of runnage varying from 50 to 300 meters/kg and twists from 10 to 30 twists/feet. Coir fibre in the form of bales is the raw material for the unit. These fibres are soaked in water for one hour and are cleaned in the willowing machine. Pith content and the hard bits are removed in the process. Manual attention is also required to remove the hard bits to the fullest extent. These cleaned fibers are passed in to the feeder of silvering machine where the fibers are paralleled and drawn by draw rollers. These paralleled fibers are twisted and taken on to drum.

The twisted paralleled fibers are called silvers. These silvers are fed on to the feeder of the spinning machine and are combed and made to fall on to "W" tray. Core threads of nylon/cotton/HDPE/LDPE. Passing in the tray are used as carrier agent for the coir fibres. These fibres are entwined on to the thread and are twisted by the grip nozzles/rollers. Two such strands are doubled and wound on to a bobbin to form the yarn of required twist and runnage. The automatic spinning machine facilitates spinning of any varieties of yarn according to the requirement of the industry by varying the parameters of the machine to vary the twist and/or runnage. The yarns thus formed are wound in the form of balls for the easy transportation.

### **Job Potential**

Coir milling and value addition, mostly spinning and weaving, are important regional employers, particularly in rural Southern India and coastal Sri Lanka. They give work to 500,000+ people, many of them women working part-time.

### **Operation and Maintenance Requirements**

As a natural material, coir, potentially, has a good image - it has excellent brushing and wearing characteristics, and it is relatively cheap. However, quality of manufacture can be mixed; the control of quality from the many hundreds of small-scale spinners and weavers is difficult to monitor and control. The range of products and designs available is strictly limited by



tradition and, moreover, the range of dyes normally used does not hold fast to the fibres and sometimes fades badly. New product opportunities are frequently well-known (non-woven materials, agro-textiles and similar), but lack of development capital, lack of R&D and testing facilities, and commercial competition, frequently preclude the sharing of industrial information. New markets have to be conceived, developed and exploited for industries to survive.

### **Social Considerations<sup>163</sup>**

Coir fibres have an image problem that has not been addressed by the trade. Coir may be environmentally "friendly" from a consumer point of view, but the same may not be the case at point of manufacture where, for example, the environmental issues of waste disposal (used chemical dyes, coir pith, etc.), pollution of water resources from retting, and the exploitation of low-paid workers, could become sensitive issues

Coir industries enable people to work close to home, enjoy the hours and conditions of work that are generally better than the equivalent in agricultural production, and to gain a sense of achievement from the acquisition of new skills, new information and a sense of participation in community development.

### **Investment and Operating Cost<sup>164</sup>**

The assistance from the Coir Board will be in the form of one time subsidy limited to 75% of the cost of motorized ratt/ motorized traditional ratt or Rs.7,500/- in the case of motorized ratt and Rs.2,625/- in the case of motorized traditional ratt whichever is less and the balance 25% will be raised by the beneficiary from either her own resources or loans from financial institutions/ voluntary organizations.

### **Economic instruments for overcoming barriers<sup>165</sup>**

Providing seed capital assistance to farmers encourages brown coir fibre production. Modernization of coir units has been envisaged by providing incentives for installation of modern equipments to make coir industry more competitive in the export market.

### **Advantages to Developing Countries<sup>166</sup>**

Processing of agricultural crops also gains; from access to raw materials at point of production, reduced transport costs, better relationships between management and workers, and the skills and intellect of an educated workforce that also has a vested interest in making the factory a success in the community. Profitability is essential for security of both worker and factory owner, and herein may be a need for enterprise support from joint private and public sector groups.

---

<sup>163</sup> <http://coirboard.nic.in/coirtrade.htm>

<sup>164</sup> <http://www.fao.org/ag/Ags/agsi/coir.htm>

<sup>165</sup> [http://coirboard.nic.in/about\\_process02.htm](http://coirboard.nic.in/about_process02.htm)

<sup>166</sup> <http://coirboard.nic.in/coirtrade.htm>

## Examples of Real Life Applications

**Level of Use** Commercial Use

**Location** Kerala, India, Commercial Level, Coir Production

### Suppliers<sup>167</sup>

- 1) Chemicals for Improvement of Fibre Quality
  - a) Amoa Chemical Company Ltd.  
Amoa House, Hawley Road, Hinckley, Leicestershire,  
LE10 OPU, United Kingdom.
  
- 2) Manufacturers/Suppliers Of Carding Equipment
  - a) Mackie International  
Belfast, Northern Ireland
  - b) Giddings Frazer  
Arbroath, Scotland, United Kingdom.
  - c) Wn R. Steward & sons (Hacblemakers) Ltd.  
Marine Parade, Dundee, Ddi 3JD  
Scotland, United Kingdom.
  
- 3) Suppliers of Sisal Tow-Yarns
  - a) The Premier Bag Co.  
P.O. Ruiru  
Kenya, East Africa
  - b) The Tanzania Sisal Authority (TSA)  
Dar-es-Salaam, Tanzania.
  
- 4) Manufacturers/Suppliers of Modern Looms.
  - a) Picanol Natural Fibre Looms  
Belgium.
  - b) Wilson & Longbottom Ltd.  
Barnsley S70 1AS, United Kingdom.

---

<sup>167</sup> <http://www.coirkerala.com/coirmachines.htm>



## Charcoal from Coconut Shell Philippines, Commercial

<b>Crop</b>	Coconut
<b>Residue</b>	Coconut Shell
<b>Process</b>	Carbonization
<b>Equipment</b>	Brick Kiln
<b>Main Product</b>	Charcoal
<b>By products</b>	

### Technical Description of Technology



The brick kiln is made of 2"x4"x8" standard rectangular bricks, constructed in a dome-shape. The kiln's dome structure is for the purpose of optimal carbonization process. Its inside has a base diameter of 1.2 meters and a net height of 1.10 meters with an approximate volume of 0.73 cubic meters. This prototype kiln can accommodate approximately 3,000 pieces of average split shells. This could be increased if the shells are semi-crushed.

The charcoal brick kiln is expected to last for five years or more with an initial investment of PhP 4,100 while the drum kiln has a serviceable life span of six months to one year, with each drum costing PhP 500.

### Advantages to Developing Countries

Coconut (*Cocos nucifera*) remains to be the top cultivated crop in the Philippines. Out of the 12 million hectares of farmlands in the country, 3.1 million hectares of it is devoted to coconut production. With the vast size of farmland devoted to coconut farming, it can be said that a large percentage of the country's population still depends on coconut for their living.

Over 3.5 million coconut farmers are widely distributed in different parts of the country, mostly in Southern Luzon and in different parts of Mindanao.

To help the coconut farmers gain extra income while attending to their farm activities, the group of Engineer Rosella B. Villaruel of the Philippine Coconut Authority (PCA) in Region X1 came up with a charcoal brick kiln where coconut shells can be turned into quality charcoals.

### Example of Real Life Applications

#### Supplier

Contact Person	Donna
Location	Fairview, Quezon City, Metro Manila - Quezon City
Price / Budget	P 300.00/ sack
Condition	Brand New
Warranty	Shop / Factory Warranty
Email address	<a href="mailto:nighel@budweiser.com">nighel@budweiser.com</a>
Cell phone no.	09062388266.
Telephone No.	(02) 4314136

#### For more information, contact:

Bureau of Agricultural Research - Department of Agriculture  
 3/F RDMIC Bldg., Visayas Ave. cor. Elliptical Rd.,  
 Diliman, Quezon City 1104  
 Trunklines: (63-2) 928-8505 or 927-0226  
 Local Nos: 2043, 2042, 2044  
 Fax: (63-2) 920-8505 or 927-5691  
 Email: [misd-acs@bar.gov.ph](mailto:misd-acs@bar.gov.ph)

Website: [www.bar.gov.ph/bardigest](http://www.bar.gov.ph/bardigest)

#### Sources:

1. <http://www.mixph.com/2008/02/making-coals-from-coconut-using-brick-klin.html>
2. <http://www.sulit.com.ph/index.php/view+classifieds/id/244956/best+buy:+coconut+shell+charcoal>

## **Coco-husk mini-decorticator Philippines, Commercial**

<b>Crop</b>	Coconut
<b>Residue</b>	Husks
<b>Process</b>	Decortication
<b>Equipment</b>	Coco Husk Micro-Decorticator
<b>Main Product</b>	Coco fiber used in the production of geotextiles, car furniture and construction materials, also used in forest nurseries, horticulture, agriculture, and for the development of golf courses. <sup>168</sup>

### **Technical Description of Technology<sup>169</sup>**

Production Capacity: 5,000 husks/day

Function/Purpose: For first pass and 2<sup>nd</sup> pass; CH-3 mixed fiber

Size (L x W x H) : 1.73 m. x 1.33 m. x 1.3 m.

Prime Mover: 18 Hp, 24 Liters/day

Operating Speed: 1,100 rpm

Weight: 300 kgs.

Parts: Housing Cylinder, Rotary Shaft Assembly, Pillow Block Bearings, Pulley, Counter Blades, Separator/Grates, Feeding Hopper, Coir Dust Outlet, Coir Fiber Outlet, Belt

### **Detailed Process Description<sup>170</sup>**

The “Coco Husk Micro-Decorticator” can process 3,000 husks per day. It separates coco fibre or coir from coconut husk by the crushing action of multiple blades welded on rotating drums. The blades cause the rapid separation of fibre and dust, as the husks are crushed against a set of fixed counter blades arranged horizontally and parallel to the axes of decortivating blades. Fibres and dust are discharged in separate outlets.

The “Coco-husk mini-decorticator”, which has a higher 5,000-husk daily capacity, produces mixed fibres 4-6 inches long (CH-3 FIDA grade) by separating them from the peat of coconut husks, through a scraping drum with multiple blades welded 94 millilitres apart. Arranged with six sets radially and eight sets axially with a five-degree helix angle, the blades drag beaten coconut husks to a series of fixed counter blades set horizontally and in parallel with the drum’s axis. This system causes rapid fibre and dust separation.

---

<sup>168</sup> <http://pcaagribiz.da.gov.ph/news01.htm>

<sup>169</sup> <http://www.mirdc.dost.gov.ph/cocoMini.htm>

<sup>170</sup> [http://www.techmonitor.net/techmon/06sep\\_oct/tm/pdf/T-scan.pdf](http://www.techmonitor.net/techmon/06sep_oct/tm/pdf/T-scan.pdf)

The blades also propel coir fibre to a discharge outlet, while forcing the dust to fall through separator or grate bars below the cylinders lower half. Fibres can be collected and sun dried, and then baled before selling or storing.

Coco fiber is used in the production of geotextiles, car furniture and construction materials. It is also used in forest nurseries, horticulture, agriculture, and for the development of gold courses.

**Job Potential<sup>171</sup>**

Two persons can operate it continuously for seven hours per day for 240 days a year.

**Operation and Maintenance Requirements<sup>172</sup>**

5,000 husks daily capacity

**MANUFACTURING COST**

Fixed Cost per Year

Salaries and Wages	Php
52,800	
Depreciation (10 years life)	
20,200	
Overhead Cost (10% of salary)	5,280

Sub total      -----  
 Php 78,080

**Variable Cost**

Material Cost

5,000 husks/day x Php0.10/husk x 22day/mo x 12 mos.      Php 132,000

Fuel Cost

16 liters/day x 22 x 12 x Php 35/liter      147,840

-----  
 Total      Php 279, 840

\*Php= Pesos

**Environmental and Social Considerations<sup>173</sup>**

Village women in Aklan are producing various products that they have made out of coconut fiber from waste coconut husks that are traditionally burned or left to rot. The nets and mats are used for soil erosion control on hillsides, riverbanks, and mangroves, and to restore badly degraded soil in forests and mining sites.

<sup>171</sup> <http://pca.da.gov.ph/n070906a.html>

<sup>172</sup> <http://www.mirdc.dost.gov.ph/cocoMini.htm>

<sup>173</sup> [http://coconutsgalore.blogspot.com/2004\\_08\\_01\\_archive.html](http://coconutsgalore.blogspot.com/2004_08_01_archive.html)

## Investment and Operating Cost<sup>174</sup>

### <sup>7</sup> INVESTMENT COST

Equipment

Php 150,000

Engine

50,000

-----

Php 200,000

=====

### MANUFACTURING COST

Fixed Cost per Year

Php 52,800	Salaries		and		Wages
20,200	Depreciation	(10	years	(10%	of
5,280	Overhead	Cost		of	salary)

-----

Php 78,080

Sub total

Variable Cost

Material Cost

5,000 husks/day x Php0.10/husk x 22day/mo x 12 mos.      Php  
132,000

Fuel Cost

16 liters/day x 22 x 12 x Php 35/liter  
147,840

-----  
Sub total      Php

279, 840

Php 357,920      Total      Manufacturing      Cost

<sup>174</sup> <http://www.mirdc.dost.gov.ph/cocoMini.htm>



### **Economic instruments for overcoming barriers<sup>175</sup>**

The Metals Industry Research and Development Center's R&D Division has successfully completed a machine designed to increase production and improve the quality of coco coir products. The MIRDC is an agency of the Department of Science and Technology that provides technology assistance to private and public sectors in developing equipment and facilities for improvement of products and services.

### **Advantages to Developing Countries<sup>176</sup>**

It will help coconut farmers cope with the rigorous work of processing coconut by-products that are in demand in the local as well as overseas markets. The machines are expected to help producers meet and sustain increasing domestic and export demand for twines and geo-textile nets particularly in China, where ground beautification is in full swing leading to the 2008 Olympics.

China is also losing about 2,400 sq.km. of land to desertification each year and needs the same size of geo-textiles to control the devastation. That figure is estimated to reach 260,000 sq.km. soon and concentrated mostly in the northern areas especially Beijing and Harbin among others. China's demand for mattress is 100 million annually, which translates to 37,500 tons of fiber per month or 450,000 tons of fiber per year. The Philippines' export capacity is only 3,000 tons of fiber per month.

### **Examples of Real Life Applications**

<b>Level of Use</b>	Research Level
<b>Name of Project</b>	Coco-husk Mini Decorticator
<b>Location</b>	Philippines

### **Suppliers<sup>177</sup>**

RESEARCH AND DEVELOPMENT DIVISION  
Metals Industry Research and Development Center  
MIRDC Compound Gen. Santos Ave. Bicutan, Taguig, Metro Manila  
Tel. Nos. 837-0431 to 38 locals 330/332



<sup>175</sup> [http://www.stii.dost.gov.ph/sntpost/NewPOST/AprJun2006/MIRDC\\_rolls\\_out\\_four\\_new\\_machines.html](http://www.stii.dost.gov.ph/sntpost/NewPOST/AprJun2006/MIRDC_rolls_out_four_new_machines.html)

<sup>176</sup> *ibid.*

<sup>177</sup> <http://www.mirdc.dost.gov.ph/cocoMini.htm>

## Making Charcoal from Corn Cobs Philippines, Commercial

<b>Crop</b>	Corn
<b>Residue</b>	Corn Cobs
<b>Process</b>	Carbonization
<b>Equipment</b>	200 liters drum, sprinkler
<b>Main Product</b>	Charcoal

### By products

### Technical Description of Technology



### Technical Description of Technology

The DENR charcoal is a solid fuel that is produced using leaves, twigs, stems and other cellulosic forest wastes. Briquettes could be produced with a density of 1.2 g/cm<sup>3</sup> from loose biomass. When burned, it emits a steady heat with low clean flame. It is easy to ignite and burns completely in at least 50 minutes. Charcoal briquette production from forest wastes was a joint project of the ERDB (initiated by Bacongus et al.) and the Forest Products Research and Development Institute (FPRDI) in 2000.

### Detailed Process Description

Raw materials were prepared by collecting wood and non-biomass materials that are traditionally considered as wastes. The materials are then sorted, chopped and dried in preparation for grinding and shredding. Light or fine materials (rice hull, leaves, etc.) were carbonized using the metal plate method. On the other hand, drum method was used for larger materials like twigs, corncobs, coconut shell, etc. Generally, raw materials were carbonized

first using the drum method or the metal plate method before they were fed to the grinding machine. These were placed inside the chopper to produce fine carbonized materials. If the materials were raw (twigs, branches, corn cobs, etc), the shredding mechanism was used. If the material was carbonized, the grinding mechanism was used. If the materials were too wet, they could be used for composting after shredding. The binder was prepared. The FPRDI recommended cassava starch because it is readily available in the market. The amount of starch used for carbonized charcoal briquettes was 6% to 15% of the total weight of raw materials. The amount of water needed to gelatinize the starch ranged from 60% to 100% of the total weight of raw materials.

Every particle of ground materials was coated with a film of binder to enhance adhesion and to produce uniform good quality briquettes. Proper proportions of ground materials and gelatinized starch were poured into the mixing container. The ground materials were mixed with the binder thoroughly. Mixed materials were converted into finished products using the manual or mechanized briquettor. The mixture was poured into the molder which transformed it into uniform sizes of briquettes. The briquettes were placed in trays and dried under the sun for two days during sunny days or placed in a suitable drier during rainy days. The dried briquettes were placed and packed in plastic bags and were sealed. Charcoal briquettes were then ready for use.

For a simpler and alternative procedure:

1. Place the corn cobs inside the drum about 1/3 in height and burn until the smoke disappears.
2. Fill the drum additional corn cobs (about 2/3 in height) and burn again until smoke disappears.
3. When the smoke ceases, empty the drum.
4. Sprinkle water into the burnt corn cobs.
5. Spread the cobs for drying under the sun.
6. Separate the charcoal from the ashes.
7. Store.

### **Advantages to Developing Countries**

Fumes from indoor cooking fires are responsible for more than 2 million deaths every year in the developing world. But by simply turning their farm waste into a cleaner burning fuel it may be quite simple to make that dire statistic a thing of the past.

### **For more information, contact:**

IRAD Science and Technology Information Institute  
DOST Complex General Santos Avenue,  
1631 Bicutan, Taguig City  
Email: science\_ebooks@stii.dost.gov.ph

### **Sources:**

1. <http://www.mixph.com/2008/04/making-charcoal-from-corn-cobs.html>
2. [http://erdb.denr.gov.ph/enr/i4d/t4d\\_uf\\_briq.pdf](http://erdb.denr.gov.ph/enr/i4d/t4d_uf_briq.pdf)

## IBS Rapid Composting Technology Philippines, Commercial

<b>Crop</b>	Ipil-ipil , Rice
<b>Residue</b>	Ipil leaves, rice straw
<b>Process</b>	Composting
<b>Equipment</b>	Drum used for composting
<b>Main Product</b>	fungal inoculants ( <i>compost fungus activator (CFA)</i> ).
<b>By-Product</b>	N/A

### Technical Description:

It is a development of the windrow type of composting, and the main innovation is inoculation with pure cultures of *Trichoderma harzianum* Rifai, a cellulolytic fungus. The fungus is cultured in sterile sawdust mixed with leaves of ipil-ipil (*Leucaena leucocephala*, a leguminous tree). The whole package — a one-kilogram pack of fungus medium in a plastic bag — is referred to as compost fungus activator (CFA). The activator is broadcast over rice straw or other plant residues when the substrate is made into a pile. It should be applied at a rate of 1% (by fresh weight) of the substrate. Adequate moisture and aeration should be provided throughout the composting period. The initial C:N ratio of the substrate should be kept low, by combining animal manure with plant materials with a high carbon content. The composting time, using this procedure, ranges from 21 to 45 days, depending on the plant substrates used (Cuevas 1988a, b).

The activator increases the population of microbial cellulose decomposers. If the compost pile has an adequate moisture content, enough nitrogenous materials and good aeration, these microorganisms multiply rapidly. The increase in the population of microorganisms raises the temperature inside the compost heap, which in turn hastens the decomposition process. The composting period is shortened to just four weeks.

The technology basically consists of two parts: the production of the compost fungus activator, and the composting process.

### Detailed Process Descriptions:

Rapid composting technology involves inoculating the plant substrates used for composting with cultures of *Trichoderma harzianum*, a cellulose decomposer fungus. The fungus, grown in a medium of sawdust mixed with the leaves of ipil ipil, is called compost fungus activator (CFA).

**Main Products:** Organic Fertilizer

**Job Potential:**

Farmers' cooperatives, private enterprises and non-government organizations were assisted to establish compost production units. Mechanization of some of the production steps was included in the program. The compost produced was sold to farmers in 50 kg bags. Assistance was given in terms of:

1. Training in the production of the activator;
2. Advise on how to use it in proper composting procedures;
3. Analysis of the nutrient content of the compost produced;
4. Mechanization of the composting process;
5. Help in obtaining credit from banks and other institutions;
6. Conduct of efficacy trials of the compost produced;
7. Registration of the compost at the FPA; and
8. Securing a license as a compost manufacturer from the FPA.

**Operations and Maintenance Requirements:**

The fungus, grown in a medium of sawdust mixed with the leaves of ipil ipil, is called compost fungus activator (CFA). There must be favorable conditions for the decay process, such as adequate moisture, an appropriate initial C:N ratio of substrates, and aeration. The composting period is shortened to just four weeks.

**Social Considerations:**

Government technicians were trained in the production of the activator, and in the composting process using this activator. These trainees in turn conducted their own training courses in their home provinces. The target of the program then changed to farmers, encouraging them to produce their own compost using raw materials such as rice straw and animal manure available on their farms.

**Investment and Operating Cost:**

One reason why large numbers of Filipino farmers were not very enthusiastic in adopting the rapid composting technology was the high labor input involved in making the compost and applying it as fertilizer. The labor demand was about 6% higher than when chemical fertilizer alone was used. The higher labor input involved: the gathering of substrates, piling substrates into heaps, and applying a large volume of compost to the field. Filipino farmers would prefer to buy commercial organic fertilizer (if this is available), rather than make their own compost.

**Advantages to Developing Countries**

The Philippines is basically an agricultural country. Most of the populations live in rural areas, and agriculture employs about 50% of the total work force. A large amount of chemical fertilizers are used: 1.4 million mt in 1995. Of this, 37% was urea, half of which was imported. In 1995, the Philippines exported

around 700,000 mt of chemical fertilizer and imported about 1,237 thousand mt, about half of which was urea. More than half the chemical fertilizer applied in the Philippines (52%) is used for rice and corn.

Organic fertilizer production began in 1974, but in 1978 organic fertilizers were less than 1% of total fertilizer sales, rising to 1.34% in 1992. As of 1993, there were 26 licensed manufacturers of organic fertilizers, and 15 processors of guano phosphate, phosphate rock, and soil conditioners (PCARRD info sheet 1996). These figures may have increased by 1996, since a number of producers of compost who use the Rapid Composting Technology have obtained licenses from the Fertilizer and Pesticide Authority (FPA).

### **Disadvantages to Developing Countries**

These three major factors — increased labor demand, inadequate nitrogenous materials and lack of water for composting — made transfer of the technology difficult in the first three years of the program. The emphasis at that stage was on convincing farmers to produce their own compost. Mass production centers for the activator were established in almost every province, so the activator would be easily available to farmers.

The two biggest problems encountered in doing this was firstly, the registration of the compost product as organic fertilizer by the Fertilizer and Pesticide Authority (FPA), and secondly, securing a license for the compost producers from FPA to allow them to produce compost commercially. The rules and regulations regarding efficacy trials for their compost were not immediately clear to the compost producers. This lack of proper information posed great problems in marketing, and was a constraint to further expansion of commercial compost production.

### **Example of Real Life Applications**

Institute of Biological Sciences,  
University of the Philippines  
Los Banos, Laguna

#### **Suppliers:**

Philippines' Department of Agriculture, Regional Field Unit No. 10, Cagayan de Oro City - Northern Mindanao

Institute of Biological Sciences (IBS) and the National Institute of Molecular Biology and Biotechnology (BIOTECH) of the University of the Philippines in Los Banos (UPLB), College, Laguna; and at the Department of Science and Technology (DOST).

#### **Sources:**

## Soundproofing and Insulating Materials<sup>178</sup> Italy, Commercial

<b>Crop</b>	Kenaf
<b>Residue</b>	Kenaf fibers
<b>Auxiliary materials</b>	Hemp
<b>Process</b>	Pulping
<b>Equipment</b>	Separator, Scutching units
<b>Main Product</b>	Soundproofing systems, thermal insulation of walls, floors and roofs, automotive components, and ecological building

### Technical Description of Technology

Kenaf fibers can be pulped either in whole stalk or separated forms. Although various pulping technologies have been tested with kenaf, the only commercial operations presently using kenaf are kraft (sulfate) mills in Thailand using whole stalk and in North Carolina using bast fiber. Kenaf is not the principal fiber source for either mill. Most of the work to date on kenaf for newsprint and other printing and writing grades has focused on a modified thermo-mechanical process, which is energy intensive.

### Detailed Process Description<sup>179</sup>

- Roundbales: after preparing the ground, seeding and cutting with special mechanical equipment, they harvest with a roundbaler and transport the bales to the first processing system, preferably located within a radius of 40-50 km, for transport requirements; usually, for the system to be able to work at full pace, it needs at least 1000 hectares of cultivation and roughly fifteen skilled workers.
- At the plant: it is designed according to the technologies for flax, modified down to the definition of blades and mechanisms suited to cope with the extraordinary strength of hemp fiber; the material of the bales is analyzed (quality, weight, moisture, impurities, state of maceration) and stored.
- Separating machine: after removing the bale rings manually, a special belt transports the bales to the aforesaid machine, which supplies the scutching units with prearranged quantities of material.
- Scutching units: the stems are stripped of their cortical and woody parts without being torn; these parts are collected on a second belt and sent to another processing sector.

---

<sup>178</sup> <http://www.hort.purdue.edu/newcrop/cropfactsheets/kenaf.html>

<sup>179</sup> <http://www.kenaf-fiber.com/en/prima-lavorazione.asp>

Cleaning station: the following stage thoroughly cleans the fibers and extractors the remaining dust (fines), which can also be used in other plants.

- Separating: they then pass on to a variable sequence of fiber opening and metering devices, along which, according to the industrial requirements, the cycle can be suspended at a specific stage or continued further.

- Exit: the fibers are pressed and made up into bales, waiting for transport. Any steeping is always done automatically, preferably enzymatically, to shorten the time. Nevertheless, till now, steeping in water still produces qualitatively better fibers.

### **Main Products**<sup>180</sup>

Soundproofing systems, thermal insulation of walls, floors and roofs, automotive components, and ecological building,

### **Job Potential**

After preparing the ground, seeding and cutting with special mechanical equipment, they harvest with a roundbaler and transport the bales to the first processing system, preferably located within a radius of 40-50 km, for transport requirements; usually, for the system to be able to work at full pace, it needs at least 1000 hectares of cultivation and roughly fifteen skilled workers.

### **Operation and Maintenance Requirements**<sup>181</sup>

The number of seeds per kilogram in most cultivated varieties varies from 36,000 to 40,000 seeds. However, some African varieties or populations have a smaller seed and the content per kilogram may reach over 100,000 seeds. According to Boulanjer, the average number of seeds per kilogram is approximately 60,000. The kenaf seed, like the hemp seed, easily loses its germinability due to its high oil content

The kenaf plant flowers at the end of the growing season, leaving a seed pod behind. The pod needs up to 90 days of frost-free weather to germinate, so it rarely survives, a factor that reduces kenaf's ability to spread and become an invasive weed. After harvest, the whole kenaf plant is processed in a fiber separator similar to a cotton gin. Kenaf can yield six to 10 tons of dry fiber per acre in four or five months of growing time, and its advocates point out that this is approximately double the hemp yield.

### **Environmental Considerations**<sup>182</sup>

Natural fibers have significant advantages over glass fibers as reinforcements in composite materials. Natural plant fibers, extracted, cleaned and product-ready, cost roughly 25 cents per pound versus 75 cents per pound for glass fiber. Natural fibers have several advantages over traditional glass fibers, including low cost, low density, acceptable specific strength and stiffness, enhanced energy recovery, carbon dioxide sequestration and biodegradability.

---

<sup>180</sup> <http://www.kenaf-fiber.com/en/azienda.asp>

<sup>181</sup> <http://www.kenaf-fiber.com/en/semi-kenaf.asp>

<sup>182</sup> <http://newsroom.msu.edu/site/indexer/512/content.htm>



The environmental impact is significant beyond the landfill. The high-fiber plants commonly used for composites are easily grown, require few pesticides and can be rotated with traditional food crops. Glass fibers require significant energy outlays for production.

### Investment and Operating Cost<sup>183</sup>

**Table 1.** Kenaf cost of production budget\*.

Costs	Quantity	Price	Cost/ha
<b>Variable</b>			
Seeding costs:	15.71 kg	\$6.61	\$103.82
Fertilizer:	109.92 kg	\$0.70	\$76.94
Fertilizer application costs:	1.00 ha	\$14.83	\$14.83
Lime	0.82 t	\$38.00	\$30.99
Spray materials:			
Herbicides	0.35 L	\$23.62	\$8.17
Insecticides	0.00 L	0.00	\$0.00
Fungicides	0.00 L	0.00	\$0.00
Irrigation:			\$0.00
Machinery			
Production, repairs			\$30.36
Production, fuel			\$19.44
Harvest, repairs			\$0.00
Harvest, fuel			\$0.00
Miscellaneous:			
Interest:	\$354.53	8.00%	\$28.36
Custom rate harvest			\$86.45
Marketing:	241.40 km	\$3.07	\$741.00
Labor charges:	7.41 hr	\$6.00	\$44.46
<b>Fixed</b>			
Machinery cost:			
Production			\$58.02
Harvest			\$0.00
<b>Total</b>			\$1,312.83
Cost per sale unit	12.35 t		\$106.30

\*No land cost included, return is calculated as net returns to land and management.

1. Kenaf enters the optimal solution for the representative grain farm when its price increases to \$120/t. This represents a 42% increase in the price of kenaf from the \$75/t assumption used in the base farm models. Net returns for the grain farm, however, increase only 13.5%, from \$72,910 to \$102,110. For the representative vegetable farm, the price of kenaf has to increase to \$100 in order to grow 81 ha of the crop. However, at \$100/t of kenaf, net returns increase by only 1%.
2. The yield of the kenaf crop needs to increase from around 12 t/ha to 19 t/ha in the grain farm model and to 17 t/ha in the vegetable farm model. This change increases net returns by 24% for the grain farm and 9% for the vegetable farm.
3. Kenaf enters the optimal solution if the transportation distance is cut from 241 to 80 km, in both models. Given that the cost of transporting a trailer load of kenaf is calculated at \$3 per loaded km, transportation costs fall from \$741/ha (destination being 241 km away) to \$245.6/ha (destination only 80 km away). This change has a more pronounced effect than the previous changes, as it results in a 33% increase of net returns for the grain farm and a 12% increase of returns for the vegetable farm.

<sup>183</sup> <http://www.hort.purdue.edu/newcrop/proceedings1999/pdf/v4-311.pdf>

### **GHG Emission Reduction Potential<sup>184</sup>**

Kenaf uses carbon dioxide as the raw material in its development, a concurrent cause of the greenhouse effect, and during its development it releases into the environment a considerable quantity of oxygen, a vital element for our existence and our eco-system.

### **Economic instruments for overcoming barriers**

From 1982 to 2002 in the EU, more than DM 100 million in subsidies was directed towards the development of harvesting and processing technologies of fiber production.

### **Advantages to Developing Countries<sup>185</sup>**

Kenaf reaps a wide range of other rewards for farmers, their families, and their communities. It's a hardy crop, resistant to most pests and diseases, and able to stand up under widely varying degrees of weather. It crowds out weeds, which limits the need for herbicide applications. Its leaves are plowed back into the earth to recycle nitrogen and other nutrients, reducing the need for heavy chemical fertilization. It's ideal for rotation with legumes, corn, sorghum, and other food crops, a practice that maintains soil quality, maximizes harvest yields, and prevents the spread of root-knot nematodes, one of the principal threats to kenaf's health.

Especially in uncertain economic times, when cash-strapped farmers often must let parcels of land lie fallow because of food surpluses dumped on the world market, kenaf's inclusion in a crop-rotation scheme can diversify income sources, increasing financial security.

### **Disadvantages for Developing Countries**

As with all enterprises, however, the emerging kenaf industry faces environmental challenges. Because kenaf requires about as much irrigation water as cotton, its cultivation in drier regions of the U.S., including southern California and the Southwest, could impact wildlife and vegetation. Care will be needed to ensure that kenaf fields are sited in areas with ample rainfall, such as the Southeast, and that they leave a plentiful supply of water for native species and habitats.

### **Example of Real Life Applications**

#### **Level of Use**

Commercial

#### **Name of Project**

Kenaf Eco Fibers Italy S.p.A.

#### **Location**

Italy

---

<sup>184</sup> <http://www.newuses.org/pdf/nova-study-full.pdf>

<sup>185</sup> <http://www.ecomall.com/greenshopping/eikena2.htm>

## **Suppliers**

K.E.F.I. - Kenaf Eco Fibers Italia S.p.A.

Registered office: via Pieve, 85 - 42016 Guastalla (RE), Italy

Operational plant: via Arginello, 48 - 46030 Dosolo (MN), Italy

Tel.: +39 0375.899074 - Fax: +39 0375.838137

E-mail: [info@kenaf-fiber.com](mailto:info@kenaf-fiber.com)



## Plasma Heated Pyrolysis Apparatus China, Commercial

<b>Crop</b>	Corn, Rice, Cotton, Wood
<b>Residue</b>	Corn Stalks, Rice Stalks, Cotton Stalks. Sawdust
<b>Process</b>	Fast Pyrolysis
<b>Equipment</b>	Plasma Heated Pyrolysis Apparatus
<b>Main Products</b>	Gasoline, chemicals, bio-oil

### Technical Description of Technology:

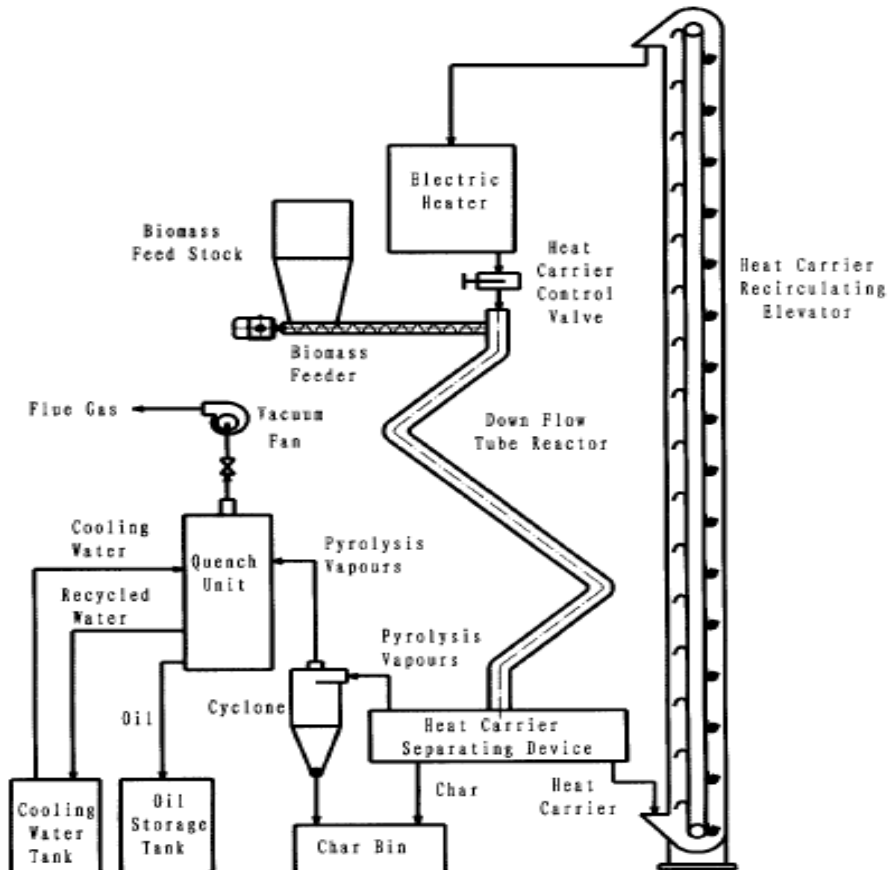

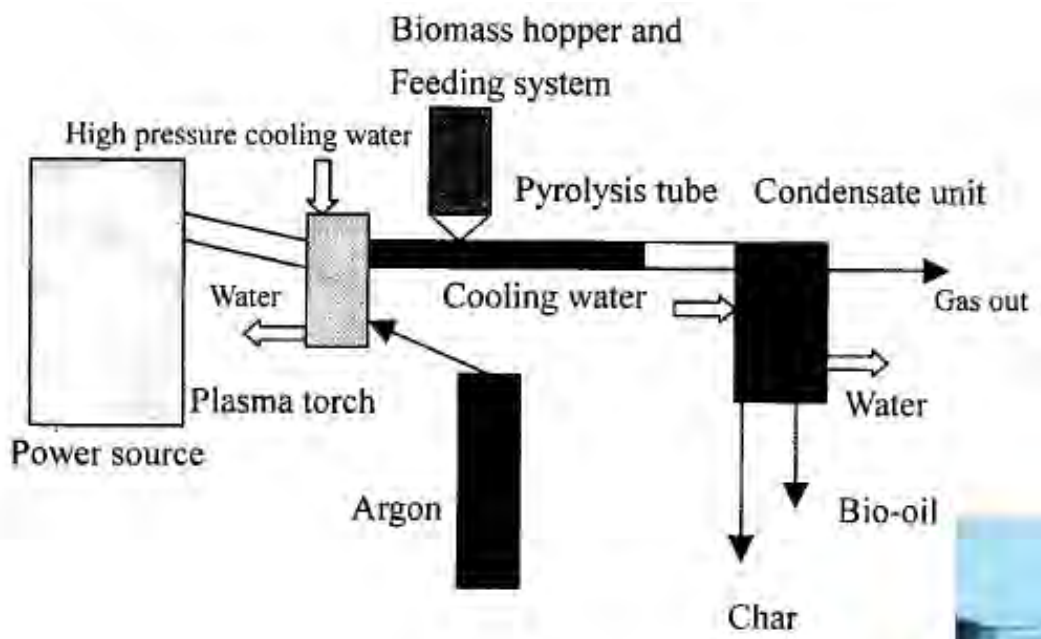

#### Detailed Process Descriptions:

1. Heat carrier is ceramic balls.
2. The ceramic balls are heated by electricity
3. Feeding capacity of biomass powder is 50kg/h.
4. Biomass powder is mixed with hot ceramic balls in a "Z" shape reacting tube.
5. Ceramic balls are heated to higher than 400°C.
6. At the end of "Z" tube, the ceramic balls and char is separated by a rotate plate.
7. The warm ceramic balls are recycled into the electric oven and heated to reuse.
8. Quench unit is a counter current heat exchanger.

**Main Products:** Bio Oil, gasoline and chemicals

#### Operation and Maintenance Requirements:

1. <10% is required from feed moisture in the drying stage
2. Fast pyrolysis requires high heating rate ( $\geq 1000$  deg C/s), moderate temperature (470~550 deg C) , and short residence time ( $\leq 2$ s)
3. Efficient char separation is needed
4. Quickly cool and condensation in the liquid recovery stage
5. Process capacity is 120kg/h feedstock

## **Social Considerations**

Prices of coal and petroleum will rise significantly as estimated by experts. In 2010, the price of artificial gas will be above RMB 5 yuan/m<sup>3</sup>, and crop stalks will more and more become discarded.

At that time artificial wood gas using stalks as raw materials will be a cheap fuel of high quality and will be doubly welcome.

## **Investments and Operating Cost**

Total investment in Sanjianpu Biomass Gas Plant in China (1995) according to the design was RMB 4.5 million yuan but actual investment is RMB 2.5 million yuan, including 0.9 million for the 1,000 m<sup>3</sup> gas storage tanks, 0.5 million for the main distribution system and branch distribution systems, 0.5 million for the pyrolyzing equipment, 0.5 million for purifying equipment and 0.1 million for others items.

It was planned to charge RMB 2,000 yuan per household as gas source fee, but the actually charged fee was 1,000 per household. The pricing of combustible gas is RMB 1 yuan/m<sup>3</sup> in accordance with the price of urban gas. Average consumption by each household daily is about 1.3m<sup>3</sup>, the same as the average consumption of Dalian inhabitants for many years, namely 2,093.5MJ per person each year. Ex-factory price of charcoal is RMB 1,600 yuan/ton, and the actual selling price of tar is RMB 3,000 yuan/ton.

Supply of gas for use by 1,000 households is equivalent to a profit of RMB 0.8 to million yuan each year.

## **Advantages to Developing Countries**

One of the features of biomass pyrolysis is the diversification of resultants. This is both an advantage and a disadvantage. If markets are found for the main by-products, great economic benefits can be obtained.

Charcoal obtained from biomass pyrolysis is a kind of charcoal purer than coal coke in both blocks and powder form. Being low in ash content, good in reactivity and large in specific surface area, it is a high-quality reducer for nonferrous metallurgy, an absorptive agent for the environmental protection industry and a soil modifier for agriculture. It therefore has a broader application than coal coke. Tar and pyroligneous liquor produced in pyrolysis is a liquid containing more than 200 components, like acetic acid, methanol, acetic aldehyde, acetone, ethyl acetate. Some components have a value as raw material in the chemical industry.

## **Disadvantages to Developing Countries**

In China, a vast majority of the population (more than 9 million) in the countryside lives in dispersed settlements. This courtyard style of living brings great difficulty to combustible gas projects and increases investment tremendously.

## **Examples of Real Life Applications**

Prof. ZHU Xi-Feng

University of Science and Technology of China (Pilot Project)

Shushan Industrial Park, Hefei, China

## PureVision Biomass Fractionation<sup>186</sup> USA, Commercial

<b>Crop</b>	Corn, wheat, wood, etc.
<b>Residue</b>	Corn stalks and wheat straw, wood residues such as forest thinnings and municipal paper wastes.
<b>Process</b>	PureVision Biomass Fractionation
<b>Equipment</b>	Reactive fractionation
<b>Main Product</b>	Paper, substitutions for wood pulp, non wood pulp and synthetically processed cellulose pulp. These pulps can be used in all forms of papers as well as a wide range of other materials including dissolving pulps for producing rayon, Lyocell and cellulose acetate fibers used in both textile and technical applications, fiber for automotive composites, and building products.

### Technical Description of Technology<sup>187</sup>

Reactive fractionation, a patented process that separates the major components of biomass and converts them into fiber, lignin and sugars for others to process into value added products. PureVision's core technology separates the primary constituents of cellulosic biomass within one pressurized reaction chamber into three streams. This continuous process employs a counter-current extraction technique that removes and recovers the hemicellulose and lignin fractions in two liquid streams, resulting in a solid fraction containing a relatively pure cellulose or fiber. This patented biomass fractionation process occurs within approximately 10 minutes.

In the PureVision process, cellulosic biomass is size-reduced and fed into a pressurized reaction chamber uniquely designed for counter-current processing. The PureVision technology can be accomplished in a single stage or in multi-stages, depending upon the desired products. A distinguishing feature of the PureVision process is the ability to efficiently separate (fractionate) biomass into its three main constituents: hemicellulose, lignin and cellulose.

---

<sup>186</sup> <http://www.purevisiontechnology.com/index.html>

<sup>187</sup> <http://www.purevisiontechnology.com/technology/technology.html>



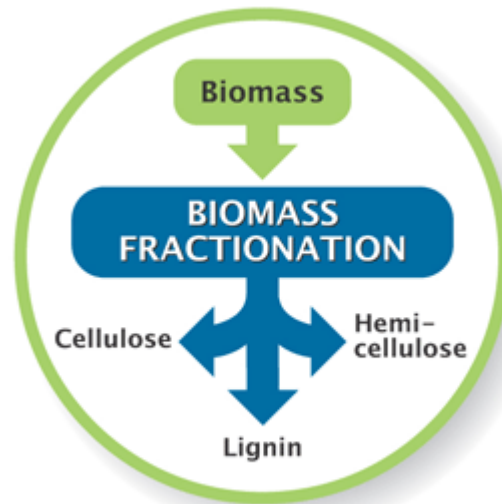

In a two-stage setup, the target within the reaction chamber is to first wash out most of the hemicellulose in the form of hemicellulose sugars while keeping as much of the lignin and cellulose intact in a solid form. After the solids enter the second half of the reaction chamber, the pH, temperature and pressure are adjusted to wash and remove as much lignin as possible. These two washing stages yield (1) the xylose-rich liquor fraction, (2) the lignin-rich liquor fraction and (3) the remaining solid and relatively pure cellulose fraction.

In the first stage most of the solid hemicellulose can be converted into hemicellulose sugars. These sugars can then be fermented to produce products such as ethanol, xylitol or furfural or can be processed into a purified xylose stream. The first wash liquor fraction also contains smaller portions of the lignin, cellulose, protein, and ash components of the biomass, most of which can be recovered.

After the counter-flow washing of the hemicellulose occurs, most of the lignin and possibly the remaining hemicellulose are washed out in a second stage. This second stage wash liquor fraction contains most of the lignin and any targeted amount of the remaining hemicellulose sugars. This lignin-rich fraction is then further processed to produce a high quality, low-molecular weight lignin that can be sold as an industrial raw material to produce hundreds of industrial and consumer products. The lignin can also be used as a bio-fuel to provide energy for making electricity and steam to run the biorefinery.

The remaining cellulose fraction is between 90% to 97% cellulose, as most of the lignin, hemicellulose and extractives have been stripped off in the wash liquor fractions. Because of the high purity of the cellulose fraction, it can be sold as a pulp or enzymatically hydrolyzed into glucose requiring far less enzymes compared to competing technologies.

### **Detailed Process Description<sup>188</sup>**

The process has the ability to efficiently separate (fractionate) biomass into these three main constituents: cellulose, hemicellulose and lignin. This

<sup>188</sup> [http://www.purevisiontechnology.com/technology/technology\\_integration.html](http://www.purevisiontechnology.com/technology/technology_integration.html)

patented technology, extensively proven at bench-scale, provides a critical process to effectively convert cellulose and hemicellulose into sugars in biorefineries. Once the cellulose, hemicellulose and lignin are separated in the PureVision fractionation process they become feedstocks for producing a wide range of bio-products for many industries including but not limited to energy, transportation, agri-business, textiles, building products, pharmaceuticals, bio-plastics and paper industries.

The biomass fractionation process includes:

1. The unique, continuous pretreatment of biomass;
2. The production of a purified cellulose product and separated wash streams containing the lignin and hemicellulose from biomass; and
3. Preparation of the purified cellulose fraction for either enzymatic conversion into sugar, which can then be converted to ethanol or alternatively for pulp and paper products.

### **Main Products**<sup>189</sup>

Because of the unique chemical composition of pulp produced from the PureVision fractionation process, potential commercial applications include paper, substitutions for wood pulp, non wood pulp and synthetically processed cellulose pulp. These pulps can be used in all forms of papers as well as a wide range of other materials including dissolving pulps for producing rayon, Lyocell and cellulose acetate fibers used in both textile and technical applications, fiber for automotive composites, and building products.

### **Job Potential**<sup>190</sup>

Most of the company's technical staff has been involved in on-going biomass processing evaluations at the Golden, Colorado research facility located at the Hazen Research, Inc.'s industrial campus. In addition to the engineers that operate the company's PDU, PureVision technical staff is involved in technical and economic evaluations of different biomass feedstocks.

### **Operational/Technical Details**<sup>191</sup>

To determine the process and economic feasibility of developing a cellulosic biorefinery in a given location, PureVision undertakes a Preliminary Feasibility Study. Planning to develop a biorefinery begins with identifying a year-round supply of cellulosic feedstock in a given location, typically not to exceed a 50-mile radius. This location should be able to provide one or more feedstocks such as wheat straw, corn stalks, wood, etc. to a well-situated biorefinery. Once the source of biomass feedstock is identified, the biorefinery developers must investigate the logistics and costing to acquire the feedstock for the proposed biorefinery.

At this point, PureVision can begin working with the developer to determine the potential location, size, biorefinery end products, financing and the economics of converting the biomass into products. If the end product involves a fermentation and distillation step, PureVision collaborators include

---

<sup>189</sup> <http://www.purevisiontechnology.com/technology/biorefinery.html>

<sup>190</sup> [http://www.purevisiontechnology.com/news/purevision\\_pilot\\_plant.html](http://www.purevisiontechnology.com/news/purevision_pilot_plant.html)

<sup>191</sup> <http://www.purevisiontechnology.com/technology/biorefinery.html>

companies with expertise in this well-understood fermentation and distillation, back-end process.

### **Operation and Maintenance Requirements<sup>192</sup>**

While each biorefinery development using the PureVision fractionation technology may differ significantly by type of feedstocks, primary product and co-products, scale of operation, financing opportunities, etc., all projects will share the need for similar information, documentation, infrastructure and equipment.

- A quantitative evaluation to supply a biorefinery with specific feedstock(s).
- A determination if target feedstock(s) need to be fractionated on a small-scale.
- A site-specific analysis to evaluate potential sites to locate a biorefinery. This study will include documenting the feedstock availability and supply in the target location, infrastructure requirements, a transportation study, and a review of regulatory issues.
- A preliminary economic evaluation addressing long-term feedstock supplies contracts and the market/pricing for product and co-products that would be produced at the biorefinery.
- A preliminary biorefinery project feasibility study inclusive of presenting the financial parameters including the costing, financing, and return on investment projections of the proposed project.

This study is expected to take approximately four-to-six months to complete.

### **Specific Considerations for Developing Countries<sup>193</sup>**

- Research study that will include determining fiber characteristics of wheat straw for pulp and other markets.
- To identify potential fiber markets including various paper and non-paper applications such as synthetically processed cellulose pulp.

### **Environmental Considerations<sup>194</sup>**

Preliminary results from Western Research Institute indicate that a >99% clean cellulose product has been achieved. This should equate to a much lower cellulase enzyme loading requirement to enzymatically hydrolyze cellulose into glucose. It is this reduced cellulase requirement that could provide the most significant cost savings in the technology.

Since 2003, PureVision has been using a continuous, small-scale process development unit (PDU) with a throughput of about 200 pounds per day of biomass. Having successfully proven the benefits of the patented PureVision biomass conversion process, the company is constructing a larger pilot plant with a throughput of about 3 tons per day of biomass.

### **Economic instruments for overcoming barriers<sup>195</sup>**

PureVision Technology, Inc., a leader in developing biorefining technologies, announced a \$990,000 financial assistance award with the U.S. Department

---

<sup>192</sup> <http://www.purevisiontechnology.com/technology/biorefinery.html>

<sup>193</sup> [http://www.purevisiontechnology.com/news/biomass\\_recovery.html](http://www.purevisiontechnology.com/news/biomass_recovery.html)

<sup>194</sup> Ibid.

<sup>195</sup> [http://www.purevisiontechnology.com/news/biomass\\_award.html](http://www.purevisiontechnology.com/news/biomass_award.html)

of Energy (DOE). The grant is a continuation of the \$1,860,000 2005 Biomass Program partially funded by DOE and will enable PureVision to continue optimizing its biorefinery technology using corn stover.

### **Examples of Real Life Applications<sup>196</sup>**

Commercial Use PureVision Technology, Inc. Ft. Lupton, Colorado

#### **Suppliers**

PureVision Technology, Inc.

511 McKinley

Fort Lupton, CO 80621

Contact Number: 303-857-4530



---

<sup>196</sup> [http://www.purevisiontechnology.com/news/biomass\\_recovery.html](http://www.purevisiontechnology.com/news/biomass_recovery.html)

## Mezcal Production from Maguey Philippines, Commercial

<b>Crop</b>	Maguey
<b>Residue</b>	Fruit
<b>Process</b>	Fermentation, Distillation
<b>Equipment</b>	Special grinding mill, Wooden barrel
<b>Main Product</b>	Low Grade Alcohol
<b>By products</b>	Alcohol/ Liquor

### Detailed Process Description

#### The Process for Making Mezcal

Mezcal is the generic name for all spirits distilled from the agave, as well as the name of a beverage similar to tequila.

1. Maguey or Agave Plant. Maguey, *Agave cantala* Roxb. plant used to make mezcal is called agave ("ah-gah-vay") or maguey ("mah-gay"). Occasionally it is called a "Century plant" in English because it can grow to be very large and has a long life-span (not really a century, more like 25 to 30 years). Sometimes mistaken for a type of cactus, it in fact belongs to a separate family, *Agavaceae*. The agave only flowers once in its lifetime, putting forth a tall stem from the center, and the plant dies after flowering. The agave that is used to make mezcal is harvested when it is seven or eight years old.



2. The Agave Piñas. After the agave is harvested, the spines of the plant are cut off and the remaining heart, called the piña (which means pineapple, because of its resemblance to the fruit), can weigh up to 100 kg (220 pounds).





3. The pit in which the agave is roasted. This is the stone-lined pit in which the agave piñas will be roasted. First a fire is started in the base of the pit, with river stones placed on top. When the rocks are red-hot, the piñas, which have been cut in half or in quarters, are placed in the pit. The whole thing is then covered with agave leaves and fiber and straw mats, piled up with earth and left to roast for four days.



4. The roasted agave. When four days have passed, the roasted piñas are removed from the pit. The roasted agave is sweet and it's often sold in markets in Mexico in chunks to be eaten. The tough fiber is chewed, then discarded.



5. Crushing the agave. The roasted agave is crushed at a special grinding mill with a stone wheel pulled by a horse or mule.



6. Fermentation of the agave. After the agave is crushed, it is placed in wooden barrels with water and left to ferment for several days.



7. Distillation. After the fermentation, the mash is distilled. The first distillation yields low-grade alcohol. The fibers are then removed from the still and the alcohol from the first distillation is distilled a second time.



8. Mezcal. After the second distillation, the mezcal is blended to obtain a consistent grade of alcohol. Then, the mezcal is either bottled or left to age in oak barrels.



9. Mezcal Presentations. Mezcal is sold in various formats:

- Mezcal blanco is aged not at all, or up to two months.
- Mezcal reposado is aged between 6 months and one year.
- Mezcal añejo is aged for at least a year.



Sometimes a worm that lives inside the agave plant is added to the mezcal at the time it is bottled. Some people say that the worm adds to the flavor of the mezcal, but it may just be a marketing gimmick. There are also cremas de mezcal which are sweetened and come in a variety of flavors, such as coconut, coffee and passionfruit.

### **Advantages to Developing Countries**

#### *Climatic Requirement*

Magwey endures diversified climatic conditions and does not require abundant or evenly distributed rainfall.

#### *Soil Requirement*

Fertile soil is not a requisite, thus, unproductive ones like rocky soil is still suitable for magwey production. It is also adapted to undulating or hill areas and grows even along the seashore.



### Method of Propagation

Applying fertilizer is optional. However, its application will greatly improve the growth of the plant. The 6-9-12 N-P-K fertilizer mixture, about 200 to 300 kilos per hectare per year is recommended.

### **Disadvantages to Developing Countries**

The continuous growth and development of the Philippine maguey industry is hampered by production and market related problems such as:

- Inefficient fiber extraction method
- Old, sparsely planted or abandoned maguey plantations
- Long gestation period before harvest (four years from planting)
- Low returns from production

### **Example of Real Life Applications**

**Level of Use:** Commercial

**Location:** Rosario, Cervantes, Ilocos Sur

### **Supplier**

Jean F. Paet - President

Cervantes Ilocos Sur Women Development Center Inc.

Maker of Maguey Slippers, Bags, Hats & Novelties

Rosario, Cervantes, Ilocos Sur

Mobile: 0918-5250900

### **Sources:**

1. <http://www.mixph.com/2008/03/maguey-production-and-its-uses.html>

## **Mobile Abaca/Piña Decortivating Machine<sup>197</sup> Philippines, Commercial**

<b>Crop</b>	Abaca, Pineapple
<b>Residue</b>	Abaca and Piña Leaves
<b>Process</b>	Decortication
<b>Equipment</b>	Mobile Abaca/Piña Decortivating Machine
<b>Main Products</b>	From Abaca- Fiber craft, cordage, textile and fabrics, pulp, and specialty papers like currency notes, cigarette paper, meat and sausage casings, teabags, stencil paper, high-tech capacitor paper, etc. From pineapple- liniuan (fine fiber) from the bastos (coarse fiber). Liniuan is the material used in weaving the elegant piña cloth.

### **Technical Description of Technology**

It has two decortivating chambers to effect the complete decortication of the whole length of the material. The other components are two sets of conveyors made of flat rubber belts; roller presser to grip and convey the materials effectively while being decorticated; and a prime mover - a 35hp diesel engine. Conveyor belts are also laid out to effectively transfer the materials from the first to the second conveyor. The structure was also redesigned for rigidity and ease of fabrication and assembly. The mobile decortivating machine consists of the following main parts:

- Paddle Wheel Assembly
- Chassis and Frames
- Wheel and Axle Assembly
- Generator
- Drag Yoke

This safe, sturdy, cheap and easy to maintain model of decortivating machine uses standard parts to assure clients of stable supply of each component. The machine is fabricated using varied metalworking processes such as metal casting, milling and tapping, turning and welding

### **Detailed Process Description**

Customarily, extraction of abaca fibers is done by hand, however, with the safe and sturdy engine-driven decortivating machine, processors can extract pulp or raw fibers by crushing and scraping processes, from either abaca or piña leaves, mechanically. The extracted fibers are main source of raw materials for bags, slippers and decorative items used by the handicraft and fiber industries.

---

<sup>197</sup> <http://www.mirdc.dost.gov.ph/BicolTechFair.htm>

### Main Products<sup>198</sup>

Abaca fiber comes from the stalk of the plant. It is processed into fiber craft, cordage, textile and fabrics, pulp, and specialty papers like currency notes, cigarette paper, meat and sausage casings, teabags, stencil paper, high-tech capacitor paper, etc.

Pineapple is a herbaceous plant with long, narrow, fairly stiff leaves with margins usually spiny except in few varieties. The fiber is extracted from the leaves of the pineapple plant. This method produces good quality fibers and makes possible the separation of the liniuan (fine fiber) from the bastos (coarse fiber). Liniuan is the material used in weaving the elegant piña cloth.

### Job Potential<sup>199</sup>

A total of 13 laborers will be employed to operate the autofed-decorticating machine continuously for 8 hours.

### Operation and Maintenance Requirements

Production of 300 kgs/day is attainable. Likewise, the working model showed a fiber recovery of 3.34%. With this information, an estimate of the profit and loss statement was prepared. As shown in the following table, an ROI of 6.18% is attainable.

Assumptions:	
Fiber production, kgs	300
Fiber recovery, %	3.34
Stalks, kgs	8,982
Sales, 300 kgs x Php20/kg	6,000
Less expenses:	
Cost of stalk, Php0.30/kg	2,695
Cost of hauling, Php0.1/kg	898
Labor: 13 x Php100	1,300
Fuel, 20 li x Php22/li	440
Repair, Php550,000 x 10%/288 days	191
Depreciation cost, Php550,000/15years/ 288 days	127
Total cost	5,651
Profit	349
ROI	6.18%

### Environmental Considerations

#### Social Considerations

The primary beneficiaries of the project are the abaca industry in general and the abaca farmers, in particular. The introduction and adoption of improved extraction machines and recommended higher yielding abaca varieties are expected to increase abaca production and generate additional employment

<sup>198</sup> <http://www.sunstar.com.ph/static/dum/2006/04/05/oped/joy.g..perez.sensitivity.html>

<sup>199</sup> [http://www.unido.org/file-storage/download/?file\\_id=48269](http://www.unido.org/file-storage/download/?file_id=48269)

in the countryside, and therefore prevent rural migration. Local abaca processors and manufacturers and foreign buyers will likewise benefit from the project with the expected increase in fiber production and the stabilization of supply. The country's gain will be in the form of increased export revenues as abaca, both in raw and processed forms, are generally for export.

### **Investment and Operating Cost**

Cost of stalk, Php0.30/kg

Cost of hauling, Php0.1/kg

Labor: 13 x Php100

Fuel, 20 liters x Php22/liter

Cost of Machine-Php550, 000

### **Economic instruments for overcoming barriers<sup>200</sup>**

The Department of Agriculture provided the funds for this project through the High Value Commercial Crops Program (HVCCP). The project aims to increase farmers' income by improving fiber quality through the mechanization of abaca fiber extraction.

### **Advantages to Developing Countries**

Only two countries deal in abaca products, one of them Ecuador, a minor second to the Philippines. Indonesia is a small producer but a potentially major competitor given its large rural labor.

- The Philippine government and private sectors here and abroad actively pursue promotional activities.
- Trainings on skills development and strengthening especially on piña fiber extraction and knotting have been continuously undertaken in Aklan, Surigao del Norte, Palawan and Negros Occidental.
- The handwoven piña fabric is considered a top fashion material catering mainly to the high-end market due to its limited supply and relatively high price vis-a-vis other natural fabrics.
- The fabrics are also made into vestments of the clergy through the initiative of the Transfiguration Foundation Inc. of the Monastery of the Transfiguration.
- Piña seda is becoming more attractive to buyers because of its comparable quality and low price.

### **Disadvantages to Developing Countries**

- Lack of supply of planting materials and piña leaves which resulted to low fiber supply;
- Lack of capital needed for the establishment of piña plantation for fiber production;
- Some scrapers and knotters find the process of fiber extraction and knotting too tedious;
- Inconsistent quality of handwoven fabrics and uneven embroidery;
- Delayed payments or issuance of bouncing checks by piña cloth buyers;
- Embroiderers sometimes resort to cut-throat competition which adversely affects the industry; and,

---

<sup>200</sup> <http://fida.da.gov.ph/>

- Being a high-priced fabric has practically limited the market for piña cloth to the upper segment of society.

### **Example of Real Life Applications**

**Level of Use:** Pilot Demonstration Level

**Name of Project:** Mobile Abaca/Piña Decorticating Machine

**Location:** Philippines

### **Suppliers**

Department of Agriculture

FIBER INDUSTRY DEVELOPMENT AUTHORITY

Asiatrust Bank Annex Building

1424 Quezon Avenue, Quezon City, Philippines

<http://fida.da.gov.ph/>

Tel: (0632) 924-79-86 Fax: (0632) 920-04-27



**Decortivating Machine**  
Philippines, Commercial

<b>Crop</b>	Pineapple
<b>Residue</b>	Leaves
<b>Process</b>	Decortication
<b>Equipment</b>	Frame and chassis, under chassis and tires, paddle wheels, feeding gate and an adjustable anvil.
<b>Main Product</b>	Fiber
<b>By products</b>	Textiles for clothing and home linens

**Technical Description of Technology**



<sup>201</sup> Decortivating machines are used to extract fibers from abaca and piña leaves by means of crushing and scraping processes. The extracted fibers are sun-dried and further processed into fabric/textile products or handicraft and decorative items. The machine is consist of the following parts: frame and chassis, under chassis and tires, paddle wheels, feeding gate and an adjustable anvil.

## Detailed Process Description

### <sup>202</sup>Methods of Extraction:



**1. Hand Stripping/scraping** - this process utilizes broken porcelain plate and manually scraping the fibers of the Spanish or native variety pineapple. Two types of fibers are produced in this method name, liniwan and bastos. After scraping the fibers, they are washed thoroughly with tap water and air dried.

**2. Decortication** - this utilizes the pineapple leaves where fruits were already harvested. The leaves are fed manually in decorticating machine where they are beaten and scraped by the revolving blades. Decorticated fibers are washed thoroughly with water and sun dried. Fibers produced are a mixture of liniwan and bastos.

**3. Retting** - is also used in extracting pineapple fiber but this method is not popular.

### Advantages to Developing Countries

The technology is locally available in the Philippines. To upgrade the Fiber Industry Development Authority's (FIDA's) existing decorticating machine, added features of mobility and safety were provided to address the following problems: 1) excessive vibration of the machine frame/body during operation due to its welded rotating paddle wheels, and 2) unsafe feeding mechanism.

To support FIDA's continuing program, IMPROVEMENT OF ABACA FIBER EXTRACTION, the Center fabricated the improved mobile decorticating machines. The fabrication was undertaken under a contract research agreement. Six units, three for abaca and three for piña, were completed and the first unit is now used in Leyte. The remaining five units will be distributed by FIDA in Samar and Leyte where piña and abaca crops abound.

### Example of Real Life Applications

---

**Level of Use:** Commercial

**Name of Project:** Livelihood projects on pineapple production and integrated leaves processing

**Location:** Labo Progressive Multi-Purpose Cooperative (LPMCP)  
Labo, Camarines Norte, Philippines

**Supplier**

Labo Progressive Multi-Purpose Cooperative (LPMCP)  
Labo, Camarines Norte, Philippines

**Fiber Industry Development Authority**

**Region XI**

**OLYMPIO B. MACARAYAN**

Officer-in-Charge

3rd Floor, GB. Cam Building

Monteverde St., Davao City

Tel: (082) 227-66-66 Fax: (082) 227-45-44

**Sources:**

1. <http://setup.dost.gov.ph/commerce.php?view=182>
2. <http://www.mixph.com/2008/02/techno-guide-on-pineapple-fiber.html>



## Rice Husk basket Burner India, Commercial

<b>Crop</b>	Rice
<b>Residue</b>	Husk
<b>Process</b>	Carbonization
<b>Equipment</b>	Basket
<b>Main Products</b>	Cement Extender from Rice Husk

### <sup>203</sup>Technical Description of Technology:

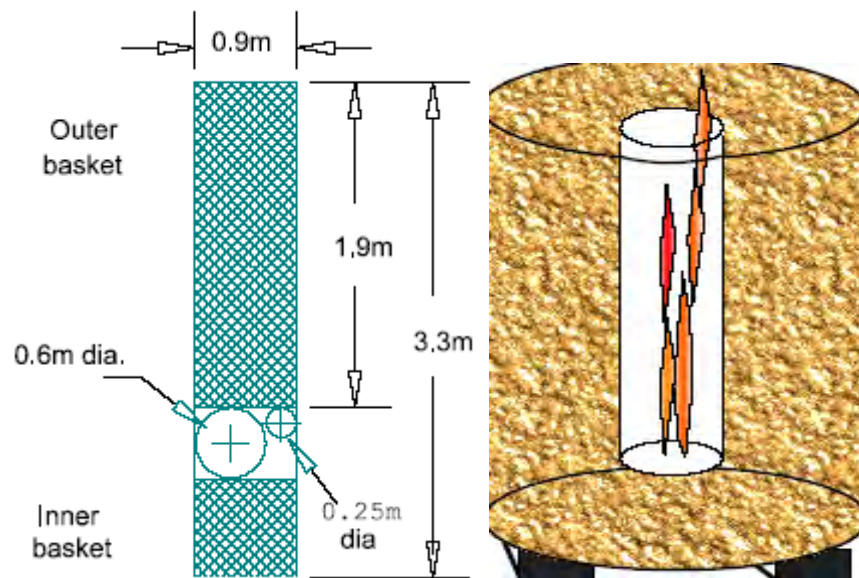

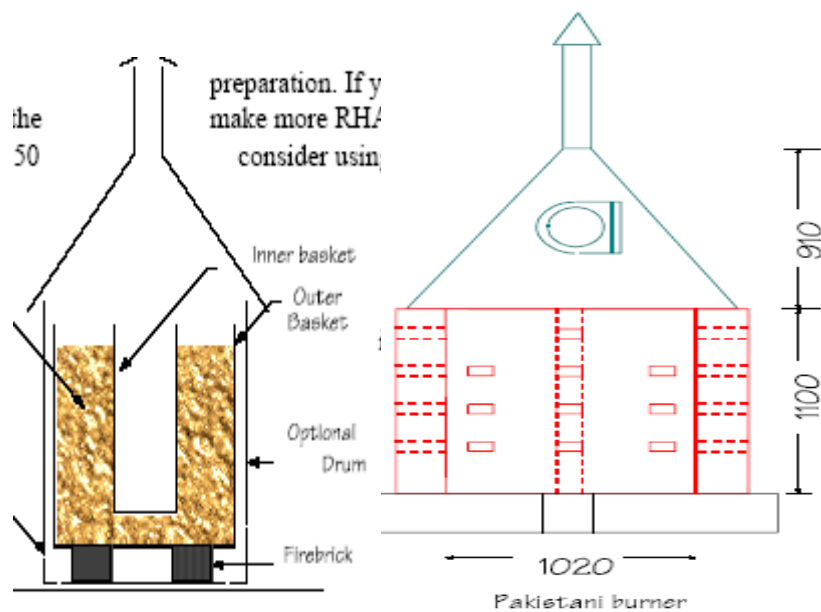

### Detailed Process Descriptions:

<sup>204</sup>The basic equipment comprises two baskets -one large and one small. One alone will work but results are more consistent if a small basket is placed concentrically inside the larger one. The reason is that the small basket allows for a more even combustion with sufficient access for air. The larger basket should be about 600 mm in diameter and about 900 mm high. An inner basket of 250 mm diam and 750 mm depth should be positioned concentrically as shown in the sketch. Both baskets are conveniently made from steel mesh having no fewer than four holes to the centimetre. (25 mesh/ins is very suitable).

The basket should be positioned away from homes because it produces smoke. However, it can be placed under a roof provided that there is sufficient ventilation. If rain or winds are expected, the basket burner should be under such a cover or inside a 200 litre drum. Dry rice-husks are placed in the large basket until a layer of 150 mm is formed. The smaller basket can then be put in place and space between filled with husks. There should be no husks placed inside the inner basket. Ignition can be achieved by dropping a piece of burning paper or hot charcoal into the central basket. Alternatively, a piece of rag soaked in used engine oil and ignited can be dropped into the central basket.

About 10 minutes after ignition you will probably see some flames. Then the burner should produce a little smoke. After about an hour, the side surfaces should be smouldering and turning black. This smouldering spreads slowly up the sides and the bed height reduces. There should be no flames produced at this stage although, as the husks collapse, there may be some sparks and a flame for a few moments. If the process is started in the morning, the ash should be ready for removal on the following morning.

The ash should be white or grey with only a little black char. If the ash is to be used as a cement-substitute or extender, it should be used as soon as possible because it loses its activity in moist air. Alternatively it could be stored in air-tight cans or double plastic bags. The basket is immediately available for making more rice husk ash (RHA) and needs no preparation.

RHA can either substitute for some of the cement in a mortar or it can be mixed with quicklime to make a hydraulic, cement-free mortar. If you are interested in making such a material commercially or testing the properties of various mixes, you should consider grinding the rice husk ash with cement (or calcium oxide) in a rod mill. The accompanying sketch above shows one made at the Asian Institute of Technology in Bangkok using a 200 litre drum mounted on a pair of car back-axles and driven by an electric motor. (Alternatively, the drum can be supported on rollers). The "rods" are from left-over pieces of reinforcing steel and should be slightly shorter than the drum so that they are free to move inside it.

**Main Products:** Cement Extender from Rice Husk

### **Operation and Maintenance Requirements**

<sup>3</sup>The basket described above takes about 20 kg of rice-husks which occupy about 0.1 m<sup>3</sup>. Typically, one burning takes about 15 hours and produces 4 kg of Rice Husk Ash (RHA).

### **Social Considerations**

<sup>4</sup>This technology can be used by village co-operatives and rice-mills where excess husks are available during milling operations. This outcome may also be of use to schools as part of a building or fund-raising exercise. The process described also has some educational value in science classes. It could usefully form the basis for either undergraduate or postgraduate research at a University because the amorphous silica formed by the basket burner can be dissolved in sodium hydroxide to produce sodium silicate. Indeed, this process may be of value to an entrepreneur because sodium silicate is a high "value-added" chemical used in the slip-casting of ceramics and also as a multi-tonne inorganic adhesive for such products as corrugated card-board.

### **Advantages to Developing Countries**

<sup>5</sup>The rice industry in the Philippines produced approximately 14.6 million tonnes of rice palay (whole rice) in 2005. Of this, 20% by weight is rice husk, i.e. approx 2.92 million tons. This is spread widely over the Philippines. Indeterminate small quantities are used as domestic fuel, animal feed, soil conditioner and as fuel for small industrial processes. Actual usage of rice husk is highly dependent on location in relation to industrial processes and therefore utilization varies considerably across individual islands and regions.

### **Suppliers**

D 31, Industrial Area , Site IV  
Sahibabad, Ghaziabad  
India

Tel : +91 (0120) 2897681

Fax : +91(0120) 2897682

Email: [info@rha.co.in](mailto:info@rha.co.in)

[pozzolabs@rediffmail.com](mailto:pozzolabs@rediffmail.com)

Overseas Agents

Seven Stars General Trading Co LLC

P.O.Box 45123, Dubai

United Arab Emirates

Tel : +9714 3516899

Fax : +9714 3556450

Email: [agamisha@emirates.net.ae](mailto:agamisha@emirates.net.ae)

### **Sources:**

<sup>1</sup> [http://journeytoforever.org/farm\\_library/RiceHusks.pdf](http://journeytoforever.org/farm_library/RiceHusks.pdf)

<sup>2</sup> [http://journeytoforever.org/farm\\_library/RiceHusks.pdf](http://journeytoforever.org/farm_library/RiceHusks.pdf)

<sup>3</sup> [http://journeytoforever.org/farm\\_library/RiceHusks.pdf](http://journeytoforever.org/farm_library/RiceHusks.pdf)

<sup>4</sup>

[http://www.klima.ph/cd4cdm/philippine\\_projects/validation/FR%20Cement\\_PD\\_D.pdf](http://www.klima.ph/cd4cdm/philippine_projects/validation/FR%20Cement_PD_D.pdf)

<sup>5</sup> <http://rha.co.in/contact.html>

## Paper from Rice Straw Cyprus, Commercial

<b>Crop</b>	Rice
<b>Residue</b>	Rice Straw
<b>Process</b>	Reuse and Recycle /Paper Pulping
<b>Equipment</b>	<ul style="list-style-type: none"><li>• A rustproof pail.</li><li>• A stainless steel pot.</li><li>• A mortar and pestle or bat and board.</li><li>• A large boiling pot.</li><li>• A sharp knife.</li><li>• Wood ash, which may from your fireplace.</li><li>• Rubber gloves.</li><li>• Sieves</li></ul>
<b>Main Product</b>	Fiber
<b>By products</b>	Paper

### Technical Description of Technology

#### Rice Straw Pulping

1. *Preparing rice straw* - Strip off the grass leaves. The nodes in stem aren't great for papermaking. Chop them off and use only the straight stiff segments of stems between nodes. Cut the rice straw about 1 inch long.
2. *Soaking* - Soak the straw in a pail of cold water at least overnight. Chinese papermakers used soak them for a week. When the water turns yellowish brown with pigment leaching out of the stems, change the water a few times during the soaking. Then rinse the soaked straw thoroughly.
3. *Making a caustic solution* - Wood ash is time consuming, but may yield better paper due to gentle cooking action and tendency to rinse out easily. The measurement of wood ash solution is 26 oz of wood ash and 15 quarts of water for one LB. of dry fiber. To make wood ash as solution, boil ash in water for half an hour and let it settle overnight. Next day, sieve the mixture into a stainless steel pot. If some ash managed to get through the sieve, line the sieve with a sheet of paper towel and filter the solution again. The solution is highly caustic - time for rubber gloves.



4. *Cooking* - Cook the soaked straw in a large boiling pot filled with the caustic solution. It would take at least three hours to break up the fibers. The rice straw is ready when it crumbles when pinched. Try not to overcook the fiber - if it tears apart too easily, your paper will be weak. Rinse the cooked straw in cool water after cooking.



5. *Beating* - The initial beating loosens the fiber strands and spreads them out. Pound the fiber with a bat. Use some force, but allow the weight of the bat to do most of the work. When the fiber has spread out, fold the fiber on themselves and start again. Beat for at least 15 minutes, until the fibers crushed into pulp.

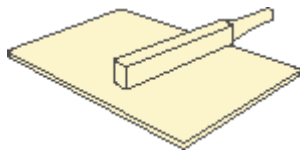

## Sheet Forming

### Equipment

- Deckle and mould.
- Vat.
- A rust-proof pail.
- Felts.
- Pressing board.
- Rolling pin.

To make a sheet of paper successfully you will need two wooden frames - deckle and mould. The top frame is deckle, which is removable and determines edge and size of paper and keeps the pulp on the mould. Thickness of deckle ensures consistent thickness of paper. The bottom frame is mould. With some fine wire gauze or plastic mesh stretched over, it drains the water from the pulp.

The bamboo frames used in Chinese floating method is beyond the ordinary practice. But you can make Western deckle and mould quite easily (See illustration bellow). The wood for making the frame set should be 3/8 x 3/8 inch in thickness. The deckle and mould should be the same size.

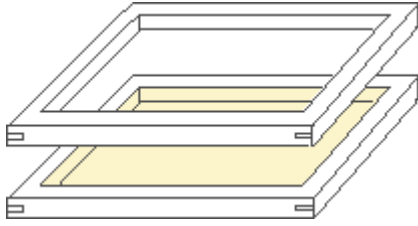

1. *Vatting* - Fill your vat halfway with water. The vat should at least seven inches deep and two inches larger than your deckle and mould. Add fiber pulp to the vat and give your pulp a good stir. While the pulp still moving, dip your mould-and-deckle, front edge first, into the pulp. Lift it out of the vat and give it a little shake. This will let fibers woven together to a stronger paper.

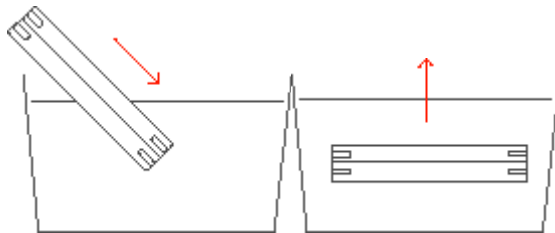

2. *Draining* - Drain the water for about five minutes. Take off the deckle. Do this carefully. If water dropped onto newly formed sheet by accident, take your mould back to the vat.
3. *Couching* - Smoothly but not too slowly roll the mould, paper side down, onto a wet felt, or a blotting paper, with a stack of newspaper underneath. This will drive away the air between the paper and felt. Gently remove the mould.

Repeat the process until you have as many sheets as you want, each with its felt between the sheets.

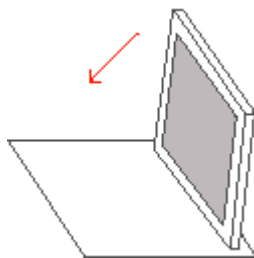

4. *Pressing* - Put another piece of wet felt or blotting paper over the newly-made papers, and press out the water with a rolling pin. Peel off the top sheet wet felt very carefully. Let it dry.

### **Advantages to Developing Countries**

In developing countries like the Philippines, the Filipinos are among the world's biggest rice consumers. The average Filipino consumes about 100

kilograms per year of rice. Metro Manila consumes up to 22,000 tons per day of rice or 16% of the country's rice consumption according to the Asia Rice Foundation (ARF). Rice consumption is increasing at an average of two percent per year. With the population of the Philippines already surpassing the 80 million-mark, rice will continue to be grown and should match production with corresponding increase in population. Rice production increased from 5.32 million tons in 1970 to 12.39 million tons in 2000. Rice hull is a processing by-product of rice milling and accounts for about 20% of the rice production. Rice straws on the other hand are field wastes after the harvesting of rice.

### **Example of Real Life Applications**

#### **Supplier:**

Our paper is imported from China, its birthplace.  
These are true papers from plant fiber (often rice straw) and not edible.

#### **WEBOLT CO.**

10192 Beaver Circle  
Cypress, CA 90630  
(714) 229-9405

#### **Technology and Action for Rural Advancement (TARA)**

B-32 Tara Crescent  
Qutab Institutional Area  
New Delhi - 110 016  
INDIA  
Tel : +91 11 696 7938, +91 11 685 1158  
Fax : +91 11 686 6031  
Email: [tara@sdalt.ernet.in](mailto:tara@sdalt.ernet.in)

#### **Sources:**

2. <http://www.rice-paper.com/about/makeyourown.html#ricestraw>



## **Ethanol Production by Acid Hydrolysis U.S.A., Commercial**

<b>Crop</b>	Rice, Corn
<b>Residue</b>	Rice straw, Corn cobs
<b>Process</b>	Hydroloysis/Fermentation
<b>Equipment</b>	Dilute acid technology, horizontal co-current reactor with a conveyor.
<b>Main Product</b>	Sugar
<b>By-Product</b>	Ethanol

### **Technical Description of Technology**

Ethanol is produced from the fermentation of sugar by enzymes produced from specific varieties of yeast. The five major sugars are the five-carbon xylose and arabinose and the six-carbon glucose, galactose, and mannose. Traditional fermentation processes rely on yeasts that convert six-carbon sugars to ethanol. Glucose, the preferred form of sugar for fermentation, is contained in both carbohydrates and cellulose. Because carbohydrates are easier than cellulose to convert to glucose, the majority of ethanol currently produced in the United States is made from corn, which produces large quantities of carbohydrates. Also, the organisms and enzymes for carbohydrate conversion and glucose fermentation on a commercial scale are readily available.

### **Detailed Process Description**

The conversion of cellulosic biomass to ethanol parallels the corn conversion process. The cellulose must first be converted to sugars by hydrolysis and then fermented to produce ethanol. Cellulosic feedstocks (composed of cellulose and hemicellulose) are more difficult to convert to sugar than are carbohydrates. Two common methods for converting cellulose to sugar are dilute acid hydrolysis and concentrated acid hydrolysis, both of which use sulfuric acid. Dilute acid hydrolysis occurs in two stages to take advantage of the differences between hemicellulose and cellulose. The first stage is performed at low temperature to maximize the yield from the hemicellulose, and the second, higher temperature stage is optimized for hydrolysis of the cellulose portion of the feedstock. Concentrated acid hydrolysis uses a dilute acid pretreatment to separate the hemicellulose and cellulose. The biomass is then dried before the addition of the concentrated sulfuric acid. Water is added to dilute the acid and then heated to release the sugars, producing a gel that can be separated from residual solids. Column chromatographic is used to separate the acid from the sugars.

### **Main Products**

Ethanol

## **Environmental Considerations**

The use of cellulosic biomass in the production of ethanol also has environmental benefits. Converting cellulose to ethanol increases the net energy balance of ethanol compared to converting corn to ethanol. The net energy balance is calculated by subtracting the energy required to produce a gallon of ethanol from the energy contained in a gallon of ethanol (approximately 76,000 Btu). Corn-based ethanol has a net energy balance of 20,000 to 25,000 Btu per gallon, whereas cellulosic ethanol has a net energy balance of more than 60,000 Btu per gallon.<sup>31</sup> In addition, cellulosic ethanol use can reduce greenhouse gas emissions. Argonne National Laboratory estimates that a 2-percent reduction in greenhouse gas emissions per vehicle mile traveled is achieved when corn-based ethanol is used in gasohol (E10), and that a 24- to 26-percent reduction is achieved when it is used in E85. Cellulosic ethanol can produce an 8- to 10-percent reduction in greenhouse gas emissions when used in E10 and a 68- to 91-percent reduction when used in E85.<sup>32</sup>

## **Investment and Operating Cost**

Conversion plant process costs (capital and operating) were assumed to be independent of production quantities. Plant size was considered in the overall cost of production, but it was assumed that savings from economies of scale would be offset by increased costs for feedstock collection. The operating costs (exclusive of energy) and capital costs for corn feedstocks were assumed to be constant over time. The amount of energy required to convert corn to ethanol, taken from Wang, was assumed to decrease linearly over time. Prices for coal and natural gas consumed during the conversion process were provided from the NEMS Coal Market Module and Natural Gas Transmission and Distribution Module, respectively. Total corn ethanol cost in the model was computed to be approximately \$1.10 per gallon in 2000. The conversion and capital cost data for cellulose, derived from Wooley et al.,<sup>46</sup> were assumed to decrease over time at rates that varied across the technological scenarios. Wooley estimates production costs for a plant with a capacity of 2,000 tons per day (approximately 50 million gallons of ethanol) at \$0.77 to \$1.04 per gallon. An average of \$0.91 per gallon was assumed as the initial cost for year 2000, resulting in a total cost for cellulosic ethanol production of approximately \$1.29 per gallon. All costs are given in 1998 dollars.

The methods of ethanol conversion assumed for this forecast varied across technological scenarios and were chosen according to their potential for cost reduction. Cumulative cost savings as a result of process improvements were based on NREL projections for each technology,<sup>47</sup> calculated from a base conversion cost of \$0.91 per gallon.

Currently, there are several projects underway to produce ethanol from cellulose using either concentrated or dilute sulfuric acid hydrolysis technology. The low technology case assumed that the technology would continue to be used throughout the forecast period, and that process

improvements would provide cost savings of 16 cents per gallon of ethanol by 2015. The countercurrent hydrolysis approach was chosen for the reference case technology. The countercurrent process improves on the dilute acid process, providing potential production cost savings of 30 cents per gallon of ethanol by 2015. The most advanced conversion process, with the greatest potential for cost reduction, is the enzymatic hydrolysis process. This process was assumed for the high technology case, with production cost savings of 60 cents per gallon of ethanol by 2015. Figure 8 compares ethanol price projections in the three technology cases with motor gasoline prices in the reference, low, and high world oil price cases.

### **Examples of Real Life Applications**

Masada Resource Group is planning to locate a municipal solid waste (MSW) to ethanol plant in New York using the concentrated acid hydrolysis process, which may be better suited than enzymes to heterogeneous cellulose sources (such as MSW). Arkenol is working to establish a commercial facility in Sacramento, California, to convert rice straw to ethanol, also using the concentrated acid hydrolysis process.

### **Sources:**

1. <http://www.ethanol-gec.org/information/briefing/6.pdf>

**Colusa Rice Straw / Hulls Technology<sup>205</sup>**  
**USA, Commercial**

<b>Crop</b>	Rice
<b>Residue</b>	Straw and Husk
<b>Process</b>	Fermentation, Distillation
<b>Equipment</b>	Bio-refinery system
<b>Main Product</b>	Fuel Ethanol
<b>By Products</b>	Silica, Metal Finishing, Water Soluble Oil & Synthetic Lubricant Coolants, Latex and Latex Paint, Pulp and Paper, Chemical & Metallurgical, Textile & Dye.

**Technical Description of Technology**

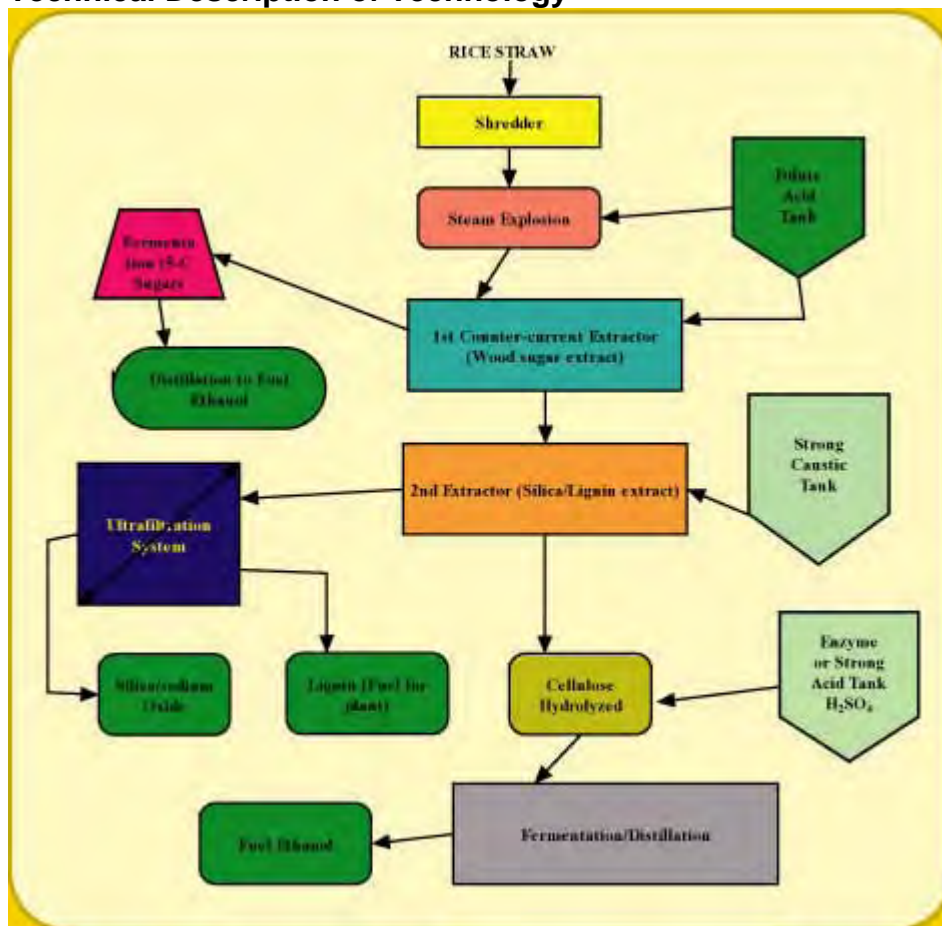

\*Green boxes are valuable secondary plant products

<sup>205</sup> <http://www.colusabiomass.com/straw.htm>

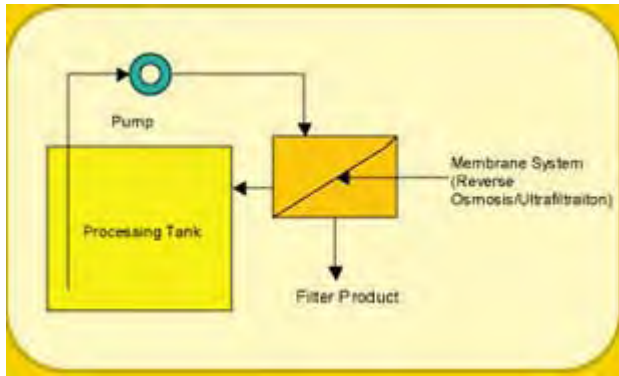

### Detailed Process Description

7. Rice straw/hulls pass through a shredder
8. Shredded material passes to a steam explosion where dilute sulfuric acid is added to the material
9. The material then passes to a counter current extractor containing NaOH solution. This process will place the silica and the lignin in solution
10. The lignin-silicate solution passes to our ultrafiltration system where the silicate solution passes through the membrane and the lignin solution is concentrated
11. The material leaving the counter-current extractor is washed and hydrolyzed, fermented and converted to fuel ethanol, or
12. The lignin fuel separated by the ultrafiltration system is used to provide energy for the operation of the plant.

### Main Products

Fuel Ethanol, Silica, Metal Finishing, Water Soluble Oil & Synthetic Lubricant Coolants, Latex and Latex Paint, Pulp and Paper, Chemical & Metallurgical, Textile & Dye.

### Operation and Maintenance Requirements

Colusa facility consumes approximately 130,000 tons of waste biomass annually, producing 12.5 million gallons of ethanol and 16,800 tons of silica/sodium oxide.

### Environmental Considerations

#### Social Considerations

Uses low cost plant waste rather than high-cost corn and grain to produce ethanol for fuel and various by-products such as lignin and silica. Highly efficient fermentation steps produce only trace amounts of CO<sub>2</sub>. Simply leaving the straw on the ground for soil nutrition requires chopping it up and re-flooding the fields with water.

### Investment and Operating Cost

The company bought a patent—U.S. Patent No. 5,735,916 in October 2004, with the \$40 million cost of capitalizing this relatively small facility, decided to take the company public.

The customized harvester collects the waste, bursts the straw's cylindrical tubes and chops it into 3/8-inch pieces. The material is blown into trailers that hold from nine to 14 tons and it is transported to one of company's three

satellite storage facilities. These storage sites have a harvesting radius of approximately 17 miles each and are located to the north, east and south of the biorefinery project location.

### **Economic instruments for overcoming barriers**

Several hundred million dollars in grant money the U.S. DOE has awarded to ethanol producers to develop commercial cellulosic technologies. The state of California also has specific grant money available for the utilization of rice straw.

### **Advantages to Developing Countries**

Ideal for an organization that produces and must dispose of plant waste, or that has a cheap local supply of plant waste from others who must dispose of it.

- High ethanol yield per ton of feed stock [94 gallons].
- Low cost of feedstock [waste straw].
- Feed stock most plentiful in world [800,000,000 tons annually].
- Low production costs of ethanol.
- Two income streams: ethanol and silica sodium oxide.
- No feed stock taken from food stream, all are Ag wastes and residues.

### **Examples of Real Life Applications**

**Level of Use:** Commercial Use  
**Name of Project:** Colusa Rice Straw / Hulls Technology  
**Location:** Colusa Biomass Energy Corporation  
California, USA

### **Suppliers**

Colusa Biomass Energy Corp.  
1023 Main Street  
Colusa CA, 95932  
Telephone: 530.458.8101  
Fax: 530.458.8106



## **Plywood from Sorghum China, Commercial**

<b>Crop</b>	Sorghum
<b>Residue</b>	Stalk
<b>Process</b>	Recycling
<b>Equipment</b>	Resin, Press Machine
<b>Main Product</b>	Plywood

### **By products**

### **Detailed Process Description**

#### **Making plywood using sorghum stalks**

The cellulose content in sorghum stalk is very high, at about 48 percentage of dry weight. Sorghum stalks are not only light, but also pliable and hard. Sorghum stalks can be used to produce sorghum plywood. Comparing shaving board and fibreboard, sorghum plywood has many advantages.

- A. Light with high strength;
- B. Better insulation capability;
- C. Highly durable;
- D. The size, thickness and specific gravity of board are suitable for multi-function applications;
- E. The holding power of nails and screws is generally lower than that of wood board;
- F. Tropical rainforests for wood making materials are conserved.

The material used for sorghum plywood is from sorghum stalks. Sorghum is an annual plant with great deal planted all over the world making it simple to get raw materials for plywood. On the other hand, sorghum stalks are by-products of sorghum. By using sorghum stalks to make plywood, farmers can earn 3000 yuan/ha more than before. Because sorghum plywood is a substitute for woodboard, it can reduce the use of wood materials to conserve acres of forests.

Shenyang Xinyang Sorghum Plywood Company Ltd., which is a joint venture of China and Japan, can produce about 60,000-m<sup>3</sup> plywood each year. Their processing method is described in Figure 1. The sorghum plywood can be used to construct tables, doors, furniture and decorative materials.

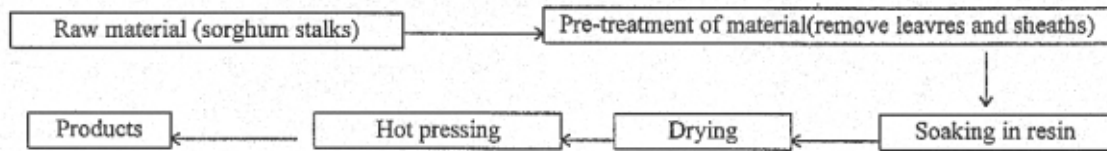

**Figure 1: The Processing Method of Sorghum Plywood**



**Figure 2: The Furniture and Ornament Made of Sorghum Plywood (the picture is kindly provided by Shenyang Xinyang Sorghum Plywood Company Ltd.)**

### **Advantages to Developing Countries**

Formaldehyde has been shown to be harmful indoor air pollutant present in high levels in many indoor spaces. Using Sorghum Board and low-VOC finishes helps reduce these formaldehyde emissions and contribute to a healthier indoor environment. Sorghum Board emits only trace amounts of naturally occurring formaldehyde existing in all organic materials. The adhesive used in the manufacture of Sorghum Board does not emit any formaldehyde into the ambient indoor atmosphere. Sorghum Boards are produced in a facility that uses low-energy processes with minimal wastewater and air emissions. Their labor force is paid a better-than-market wage and works in good conditions.



## **Example of Real Life Applications**

Location: China

Level of Use: Commercial

### **Supplier:**

Shenyang Xinyang Sorghum Plywood Co, Ltd.

No. 1 Minzu Street, Urban area, Xinmin, Shenyang, Liaoning, China

+86-024-27623594

### **Sources:**

1. <http://www.fao.org/inpho/content/compend/text/ch08.htm#Pg00020>

## **Syrup Production from Sweet Sorghum India, Commercial**

<b>Crop</b>	Sweet Sorghum
<b>Residue</b>	Stalks
<b>Process</b>	Extraction/Filtration
<b>Equipment</b>	Weighing balance, Bottling machine, Crown capping machine, Other accessories such as 200-mesh stainless steel wire gauze sieves, skimmers, buckets, hand refractometer, thermometer, sterilized bottles, crown caps, crusher
<b>Main Product</b>	Syrup
<b>By products</b>	

### **Technical Description of Technology**

For making syrup on large scale the following equipments are required:

- a) A 3-roller crusher that can give an extraction of at least 45–55%. More efficient crushers will give higher extraction percentage and thus enhance syrup recovery.
- b) Settling tank.
- c) Motor for pumping juice.
- d) Flat- bottomed aluminium or stainless steel vessel (kadhai) having a capacity to boil 350-400 litres juice.
- e) A conventional furnace with at least 10-15% overall efficiency or a gasifier-powered furnace. NARI has developed a multifuel gasifier which can be run on sweet sorghum bagasse, sugarcane leaves, wheat husk, grasses etc (Fig. 4). A pilot gasification plant of 300-500 kW (thermal) capacity was set up giving 20-27% overall efficiency (biomass to useful heat) (Rajvanshi, 1992). It was environmentally very clean as there was no smoke production. [The gasification system produces char as a by-product (20-25% w/w of fuel). This char can be mixed with a suitable binder (15% w/w cow dung) to produce excellent smokeless fuel briquettes for chulhas (stoves). Besides, preliminary results indicated that this char could also act as a soil conditioner when applied to fields].

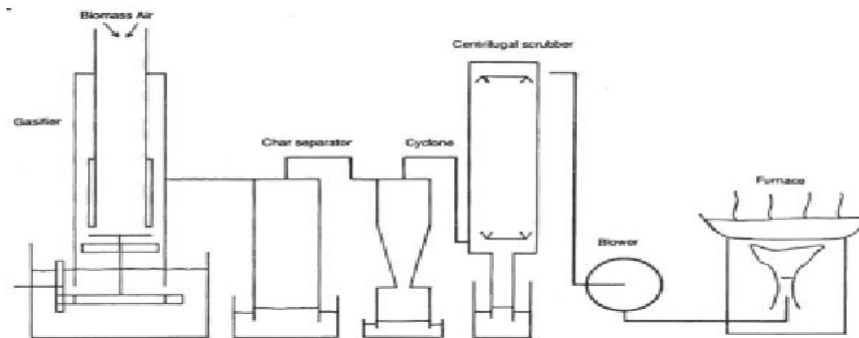

Figure 1. Schematic of gasifier-powered syrup making furnace

### Detailed Process Description

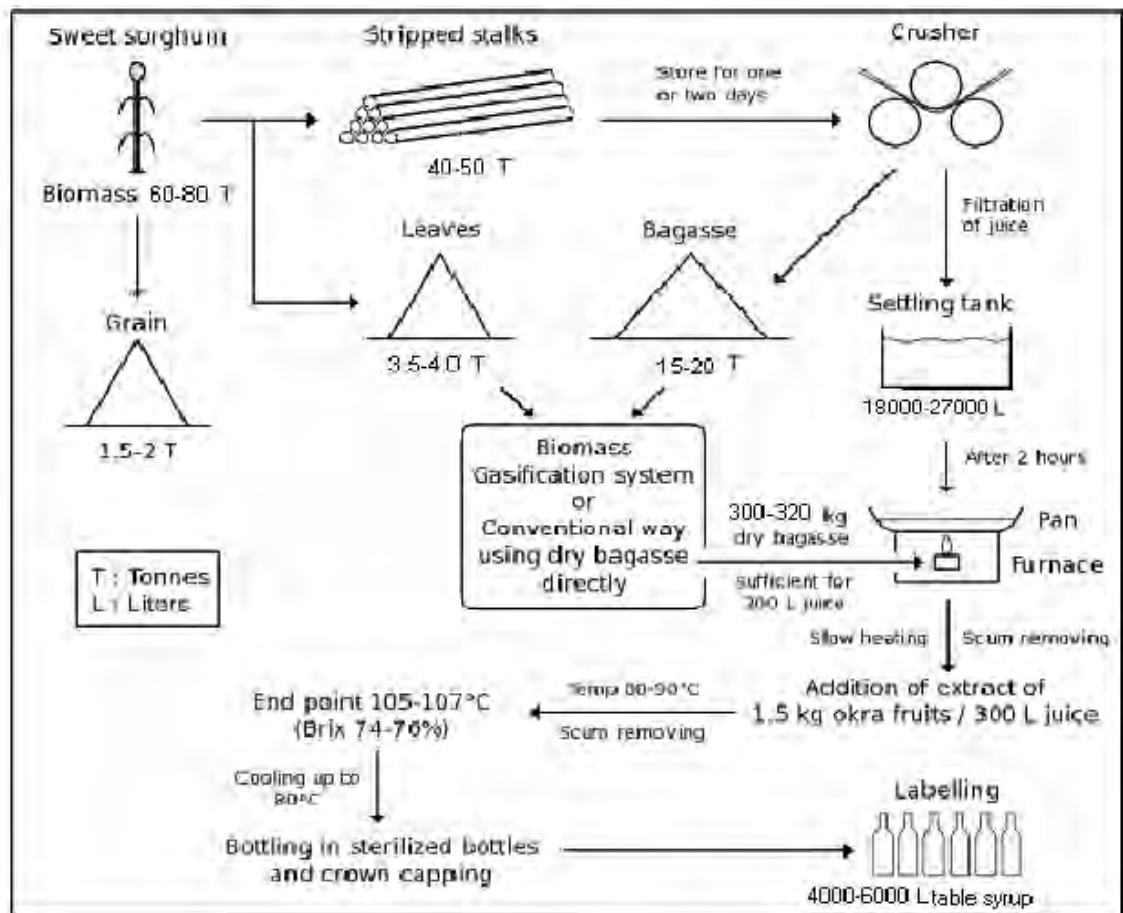

Figure 2. Schematic Diagram of Syrup Production from Sweet Sorghum (ha/season)

1. Stripping of stalks: Harvested stalks are stripped by removing the leaf lamina along with the sheath and panicles with peduncle as these contain very little sugar. The stalks are stored in shade for one or two days before milling for juice extraction. This conditioning allows the inversion of sucrose to reducing sugars and thus improves the quality of juice. Conditioning of stalks before milling also removes excess moisture from the stalks and increases the brix of juice which ultimately helps to reduce the time and fuel required for syrup concentration.

2. Extraction of juice: A horizontal 3-roller power mill (crusher) strong enough to apply 50-100 tonnes of pressure on the stalk is used to crush the millable stalk for extraction of the juice. Passing the same stalk 2-3 times through the crusher gives maximum extraction. Bagasse obtained after juice extraction makes excellent roughage for livestock with proper supplementation or it can be used as a fuel for juice evaporation process after drying.
3. Filtration and settling of the juice: Sweet sorghum juice has low purity. Apart from sugars it contains soluble solids like anthocyanins and chlorophyll and insoluble solids such as starch granules. The extracted juice should be strained through a wire screen to remove big pieces of crushed material and then strained through a fine mesh screen to the settling tank. This is to be done so as to get clean juice. The strained juice should be kept undisturbed for 1-2 hours for settlement of starch granules and then the supernatant juice (keep at least 3-4 cm juice from the bottom of the tank undisturbed) is pumped into the evaporation pan (kadhai) installed on the furnace.
4. Evaporation process: This is the most critical aspect of making high quality syrup. To improve the overall quality of sweet sorghum syrup, paying close attention to the cooking process is most important. Good quality syrup can be made after carrying out evaporation with continuous skimming of coagulated materials, which have risen to the surface. To make chemical-free syrup only okra (*Hibiscus esculentus*) aqueous extract should be used to facilitate scum removal. Filtered extract of 1.5 kg okra fruits crushed in a mixer is sufficient for effective scum removal from 300 liters of juice. Evaporation should be done with uniform heating. Initially coagulation starts when juice temperature increases. This scum should be removed during slow heating. Then okra solution should be added in three to four equal instalments in boiling juice for effective scum removal. Evaporation should not be done fast as scum gathered on the top of the juice may get dissolved during rapid boiling and then floating or settled mass problems may be seen in the syrup made. If scum is completely removed then syrup clarity is observed to be good. In case of non availability of fresh okra fruits, about 500 g powder of dried okra plants can also be used instead of fresh okra fruits for effective scum removal from 300 liters of juice.

### **Advantages to Developing Countries**

In developing countries like the Philippines, the Filipinos are among the world's biggest rice consumers. The average Filipino consumes about 100 kilograms per year of rice. Metro Manila consumes up to 22,000 tons per day of rice or 16% of the country's rice consumption according to the Asia Rice Foundation (ARF). Rice consumption is increasing at an average of two percent per year. With the population of the Philippines already surpassing the 80 million-mark, rice will continue to be grown and should match production with corresponding increase in population. Rice production increased from 5.32 million tons in 1970 to 12.39 million tons in 2000. Rice

hull is a processing by-product of rice milling and accounts for about 20% of the rice production. Rice straws on the other hand are field wastes after the harvesting of rice.

### **Example of Real Life Applications**

'Madhura' syrup  
Nimbkar Agricultural Research Institute (NARI), Phaltan, India  
E-mail: nariphaltan@sancharnet.in

### **Sources**

1. <http://nariphaltan.virtualave.net/syrup.pdf>

## Syrup from Sweet Sorghum U.S.A., Commercial

<b>Crop</b>	Sweet sorghum
<b>Residue</b>	Stalk
<b>Process</b>	Crushing
<b>Equipment</b>	
<b>Main Product</b>	Syrup
<b>By products</b>	

### Technical Description of Technology



**Figure 1. [A typical large mill for squeezing the stalks](#)**

A horizontal 3-roller power mill with crushing capacity to provide enough juice to keep ahead of the evaporation process is desirable. However, vertical mills are adequate for many small operations. To set the mill rollers initially, evenly space the feed roller  $3/8$ -inch from the top roller. The feed roller is not intended to grind the cane but to mash it so that the extraction roller can grind it. The space between the extraction roller and the top roller should be  $1/16$ -inch. The rollers should be tilted so that the front opening is at least  $20^\circ$  below the rear opening to let the juice flow quickly away from the extraction roller. Usually, in small mills the speed of the top (large) roller is 10 to 12 revolutions per minutes (RPM). For large mills, the speed may be adjusted to 6 to 8 RPM.

The size of the mill or number of mills employed will be determined by the size of the processing plant. Smaller producers (25 acres or less) will need at least one 3-roller mill (horse-drawn or power) with feed rolls from 12 to 18 inches long and 6 to 12 inches in diameter. A large processing operation will need one or more 3-roller power mills with feed rolls up to 24 inches long and 12 inches in diameter. Because the processing season is short (fewer than 60 days) and the amount of syrup produced depends on the quantity of juice extracted, it is imperative to have reliable and efficient milling equipment. Because no commercially available new mills are being made, you may need to buy an old mill and have it regrooved and repaired.

Check the mill to see how much juice it extracts. Under normal conditions, an efficient mill will deliver 45 to 50 pounds of juice from 100 pounds of clean stalks. Weigh 100 pounds of stalks, run them through the mill, catch and weigh the juice. If necessary, tighten the rollers to increase extraction of juice. A mill should be strong enough to apply from 50 to 100 tons of pressure on the stalks.

As a general rule, juice is lost if the crushed stalks contain visible juice and are not broken at the joints as the stalks come from the mill. Many older mills are not capable of being adjusted tightly enough to reach this total amount of extraction without breaking. When adjusting, always tighten rollers down slowly.

### **The Processing Building**

The building where the juice is evaporated into syrup should be a sanitary area suitable for food preparation. The area should be covered and screened to keep out flies, birds, and other animals including pets. The floor should be made of concrete or other impervious material and should be graded to drain so it can be washed with water after the day's operation. A pressurized, approved water source for cleaning and hand washing should be available. Hand-washing facilities, complete with soap and single-service towels, must be available in the processing area. A sanitary toilet should be conveniently located. The general sanitary conditions in and around the processing area should be kept high at all times.

### **Filtering and Settling the Juice**

As the raw, pea-green juice runs from the mill, it should be strained through a wire screen into a juice box. This straining removes the larger pieces of suspended matter such as stalk fragments.

The juice should then be run through a pipe or hose to the juice settling tanks where it is strained through a fine mesh screen or fine nylon cloth as it enters the tank. Use 2 or 3 tanks, each big enough to hold the juice from 2 to 3 hours of milling.

Let the juice settle from ½ hour to 3 hours before drawing it off, depending on its quality. Holding it more than 3 to 4 hours without refrigeration or without heating (as described later) may cause it to ferment and spoil. Do not draw it

from the bottom of the settling tank, but at least 1 inch above the bottom of the tank so the settled material is not drawn into the evaporator. A separate opening in the bottom of the tank will be necessary for cleaning out the tank after drainoff.

For larger operations, the juice is heated in the settling tanks, enzymes are added, and skimmings are removed before the juice is moved into the evaporator pan.



**Figure 2. Evaporation Pan used for large operations**

## **The Furnace and Evaporator**

### **Furnace Fuel**

Many of the older furnaces in use are still using wood as a heat source. However, as wood becomes scarcer or as new operations are installed, the major source of heat is petroleum fuel. Steam is the most ideal method of heating especially for large operations.

### **Evaporator Design**

Evaporators may be batch (kettles) or continuous flow types. The 12-ft continuous flow evaporator is the most common.



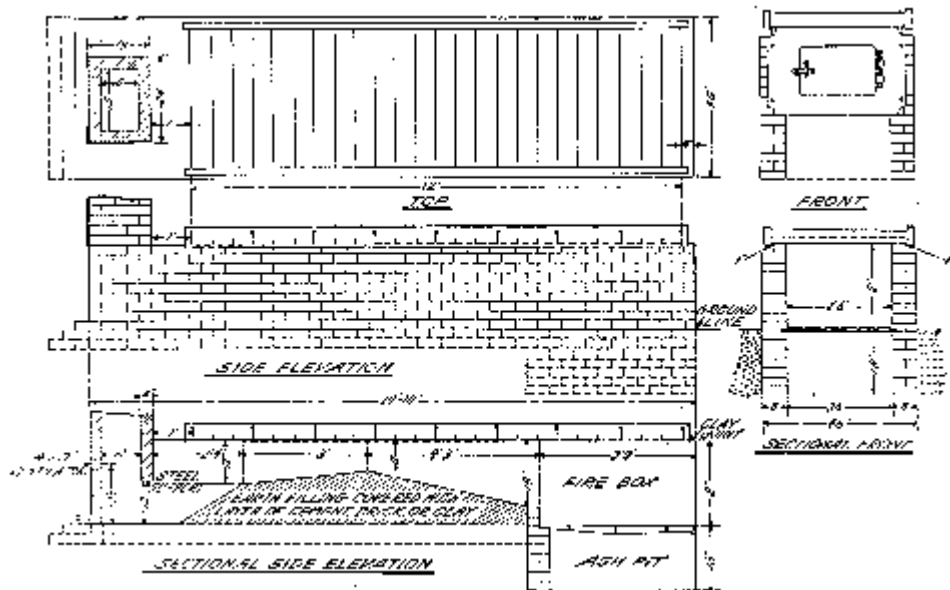

**Figure 3. A 12-ft continuous evaporator and furnace**

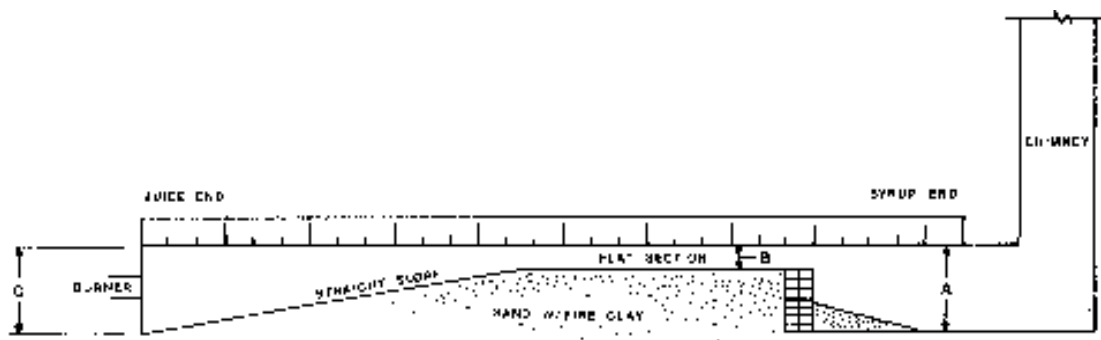

**Figure 4. Typical Configuration for Propane Burner Heat Source**

## Detailed Process Description

### Pre-Heating the Juice

Pre-heating the juice prior to evaporating reduces the amount of skimmings left in the juice and lessens the time for cookoff. After the juice has been squeezed from the cane, it can be placed into large stainless steel containers, pre-heated to 160° to 180°F, and allowed to settle for 1 or 2 hours. During this process, many of the impurities in the juice will rise to the top and others will precipitate to the bottom of the tank. The juice is then drawn from about 2 inches above the bottom of the pan (above the settled material) until the skimmings on top of the juice reach that level. Clean out the impurities from the tank, and it is ready to be refilled with fresh juice.

## The Evaporation Process

Evaporating the juice is not difficult, but it must be done intelligently if a good quality syrup is to be produced. As the extracted juice is heated, some undesirable properties in the juice such as proteins and non-sugar substances are coagulated. These coagulated materials (skimmings) will rise to the surface and need to be removed. Continuous flow pans are somewhat more efficient but require more skill in their operation. Regardless of the evaporation method used, the boiling juice must be continuously skimmed to produce high quality syrup. The skimmings are rich in protein and starch as well as some sugar and can be used for animal feed. However, most skimmings are discarded into a waste area or buried.

To enable the juice to evaporate uniformly from the pan, you need to control the temperature along the pan's length. The boiling temperatures of the juice starts about 25 percent of the length of the pan from the juice end and remains at a constant temperature until the skimmings are completely removed before reaching the last 25 percent of the pan. As the syrup density increases, the boiling temperature will rise gradually. Evaporation should be done as rapidly as possible but not so fast that you let the syrup burn. Juice cooked off too fast will be dark and contain small, dark particles of non-removed impurities. The pan should be at least 1 inch higher at the syrup end than at the juice end. This allows the juice to be about 2 inches deep at the juice end and from 3/4 to 1 inch deep at the syrup end. As the syrup is removed, the juice will push the unfinished syrup toward the finish end to keep the juice from getting too shallow and thus prevent burning.

Remove the syrup from the evaporator when it reaches 226° to 230°F (108° to 110°C) or when it reaches a density of 78° to 80° Brix with a syrup hydrometer or sugar refractometer. Inexperienced operators (and sometimes experienced ones) should use a good thermometer to determine when the syrup is finished.

Draining off the finished syrup is not especially difficult, but remember that no part of the pan should be dry for more than an instant or the syrup quality may be impaired. The semi-syrup in the center of the pan must be allowed to follow closely behind the syrup being moved to the outlet.

As the finished syrup is removed from the pan, it should be cooled and strained before being placed in a large container. Cool the syrup to 140° to 160°F as it is removed from the pan. Some producers pump the finished syrup through a pipeline that passes through an enclosed cool water tank to lower the temperature quickly. A simpler method involves running the syrup down a wide trough for 6 to 10 ft with a cool water jacket beneath the trough. The syrup should then be strained through muslin, two thicknesses of cheesecloth, or 45-mesh screen wire before going into holding containers for canning. Excellent straining cloth may be obtained from any bee or honey supply outlet. This quick cooling maintains the syrup's more natural color compared to slower cooling methods.

The finished syrup is thoroughly sterilized by boiling. If canned above 150°F in clean containers, it will not spoil or ferment. The container must be airtight to prevent fermentation or surface mold growth. Thoroughly wash large containers such as metal drums several times with boiling water or steam and dry them thoroughly before adding syrup. Large wooden containers such as kegs or wooden barrels are not recommended for storing syrup because they are so hard to sanitize. It takes from 6 to 12 gallons of raw juice to make one gallon of sorghum syrup. The finished syrup will weigh about 11.5 pounds per gallon.

### **Investment and Operating Costs**

Often, sorghum syrup will crystallize during storage and become a problem for producers who store their syrup through part of the winter. Crystallization is caused when the sugar sucrose is present in concentrations greater than its solubility at the storage temperature. You can prevent crystallization if some of the sucrose is converted to glucose and fructose (other forms of sugar) with the enzyme invertase.

As with the amylase enzymes, invertase can be added at several times while the syrup is being processed. The recommended method is to finish the syrup in the usual manner and cool it to below 140°F. Then add 1 pound invertase per 100 gallons finished syrup and immediately bottle. The enzyme will slowly convert the sucrose into glucose and fructose over the next few weeks. The syrup will probably become slightly thinner, but the sweetness will remain the same.

### **Suppliers:**

#### **Kentucky**

- Danny Townsend - 11620 Main St., Jeffersonville, KY 40337, Phone (859)498-4142
- Sandra and Thurman Shumaker - sTs Farm, 7161 Wickliffe Rd., Wickliffe, KY 42087; Phone: 270/335-5035; [www.stsfarm.com](http://www.stsfarm.com); [tshumaker@brtc.net](mailto:tshumaker@brtc.net)
- Country Rock Sorghum, Versailles, KY. Curtis Congleton, Jr. and Randal Rock, Phone: 859/873-8497, e-mails: [ccfarmdude@aol.com](mailto:ccfarmdude@aol.com) and [rock@mis.net](mailto:rock@mis.net).

#### **Alabama**

- BriarTree Sorghum Farm - P.O. Box 52, New Market, AL 35761, Phone (256)379-3446, e-mail: [BriarTreeSorghum@yahoo.com](mailto:BriarTreeSorghum@yahoo.com)

#### **Indiana**

- Hubert Farms, Stephen E. Hubert, 10685 E County Road 1700 N, Ferdinand, IN 47532-7562, Home Phone: (812) 357-2164 Cell Phone: (812) 719-1898

## Iowa

- Charles Kramer - 6495E. 132 St. S., Lynnville, IA 50153, Phone (515)594-4376 [www.maasdamsorghum.com](http://www.maasdamsorghum.com), e-mail: [sorghum@netins.net](mailto:sorghum@netins.net)

## Missouri

- Sandhill Farm, Inc, Stan Hildebrand - Rt. 1, Box 155, Rutledge, MO 63563. Phone: 660/883-5543, e-mail: [sandhill@ic.org](mailto:sandhill@ic.org). Organic sorghum syrup.

## North Carolina

- John Matthews, Jr. , Old School Sorghum, Garland, NC. 910/564-5069, e-mail: [jamjr@intrstar.net](mailto:jamjr@intrstar.net)
- Richard Warfford, 2173 New Castle Dr., Winston-Salem, NC 27103. 336/659-6879.
- Spring Hill Merchant, P.O. Box 533, Bostic, NC 28018, 828/289-5603. [www.springhillmerchant.com](http://www.springhillmerchant.com) | [terri.watts@springhillmerchant.com](mailto:terri.watts@springhillmerchant.com)

## Tennessee

- Muddy Pond Sorghum Mill, Pete Guenther, 4363 Muddy Pond Road, Monterey, TN 38574, Phone (931)445-3589, e-mail: [petendoreen@twlakes.net](mailto:petendoreen@twlakes.net), website: [www.muddypondsorghum.com](http://www.muddypondsorghum.com)
- Ernest Mazelin - 4570 Muddy Pond Rd., Monterey, TN 38574, Phone (931)863-3859
- Clinton Family Farms; Brownsville, TN; 731-772-4878; [www.clintonfamilyfarms.com](http://www.clintonfamilyfarms.com) or [glonej@bellsouth.net](mailto:glonej@bellsouth.net). We have 16oz @\$5.00; 32oz @\$8.00; 48oz @\$12.00, plus shipping.

## Wisconsin

- Rolling Meadows Sorghum Mill, Richard Wittgreve - N. 9030 Little Elkhart Lake Road, Elkhart Lake, WI 53020 Phone (920)876-2182, e-mail: [sorghum@excel.net](mailto:sorghum@excel.net)

## Sources

1. <http://www.ca.uky.edu/agc/pubs/agr/agr123/agr123.htm>
2. <http://www.ca.uky.edu/nsspapa/purchase.html>

## Drinking Vinegar from Sweet Sorghum Singapore, Commercial

<b>Crop</b>	Sorghum
<b>Residue</b>	Stalk
<b>Process</b>	Saccharification and Fermentation
<b>Equipment</b>	Fermenter and digester
<b>Main Product</b>	Vinegar
<b>By products</b>	

### Technical Description of Technology

#### <sup>206</sup>Detailed Production Process

---

<sup>206</sup> <http://www.drinkingvinegar.com/page12.html>

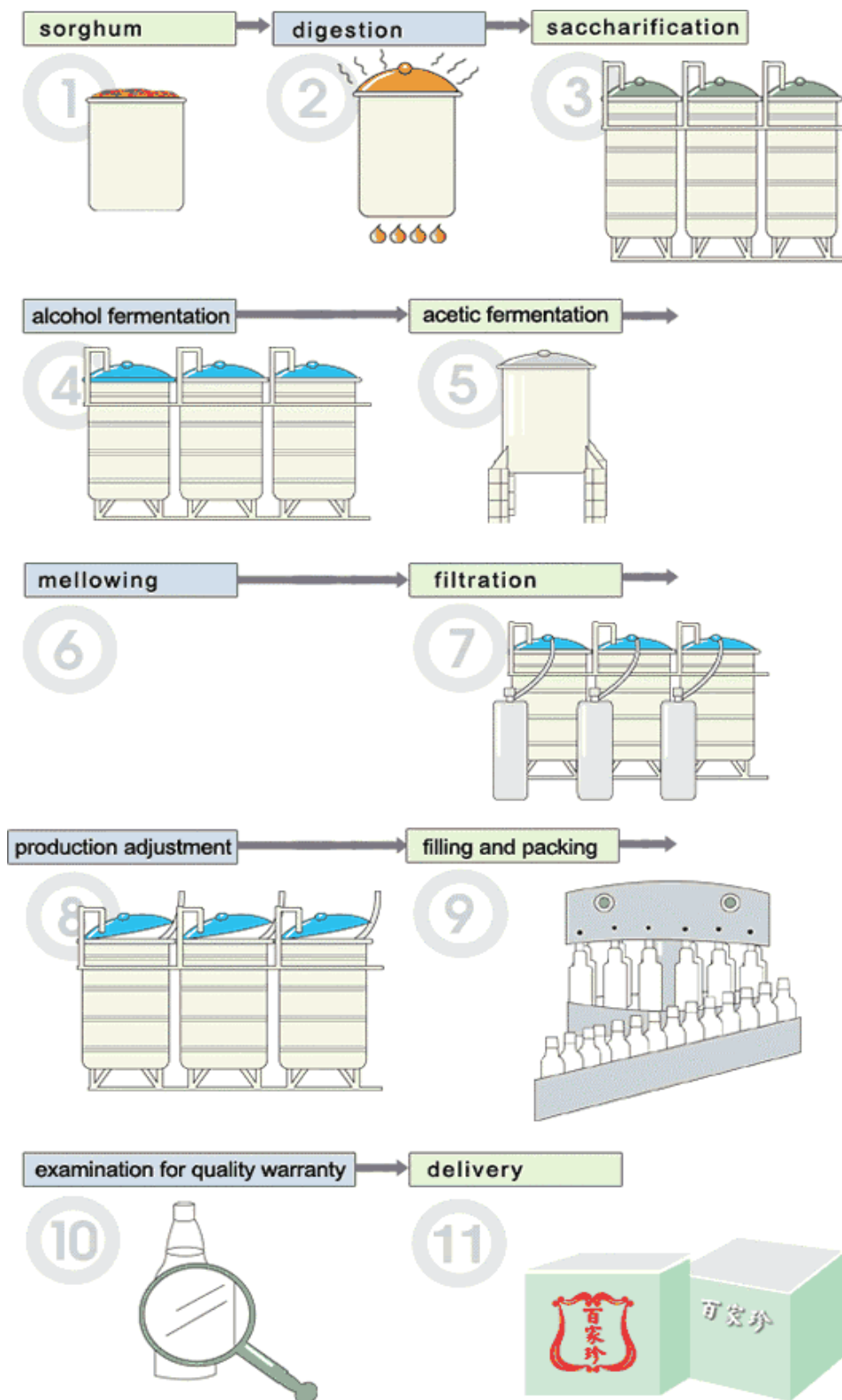

### Advantages to Developing Countries

<sup>207</sup>Sweet sorghum like sugarcane is rich in sugar. But compared to sugarcane which takes 12-16 months to mature, sweet sorghum's gestation period is

<sup>207</sup> <http://www.mixph.com/2007/09/sweet-sorghum-raw-material-for-ethanol.html>

only four months. Ethanol, a cheaper source of fuel, is the valuable product derived from processing sweet sorghum. Once ethanol is combined with diesel, it is converted as “gasohol.” Sweet sorghum can be used as animal feed after extracting ethanol.

### Important Features of Sweet Sorghum

1. Seed crop matures in 100-110 days after emergence (DAE), the ratoon in 85-95 days after cutting. Sugarcane is harvested 300-330 DAP.
2. Because it is early maturing, it can be planted as a component crop in a multi-cropping system. It can be planted after rainfed lowland rice, upland rice, corn or legumes.
3. Drought tolerant. [ICRISAT](#) data has shown that sweet sorghum needs about 4,000 m<sup>3</sup> of water/crop while sugarcane needs more than 36,000 m<sup>3</sup> per crop.
4. Since sweet sorghum is drought tolerant, it can be planted after rainfed lowland rice. It can be a good alternative crop for tobacco in areas where high quality leaves cannot be produced.
5. Higher yield per unit area per unit time.
  - sugarcane: 65-95 ton/ha.
  - sweet sorghum: 50-60 ton/ha in 100-110 DAE see crop; 45-65 ton/ha in 85-95 days after cutting (DAC) in ratoon crop (or 95-125 ton/ha from the same piece of land in 190-210 days compared to 65-95 ton/ha in 300-330 days in sugarcane). A second and third ratoon can be harvested with a stripped stalk average yield of 60 ton/ha.
6. Sugar content: 15-23%; normally higher during dry season.
7. Fertilizer requirement - 80-60-60 for clay soil; 100-60-100 for sandy loam.

### Example of Real Life Applications

**Country:** Singapore

**Level of Use:** Commercial

### Supplier:

Chung Hwa Food Industries (Pte) Ltd



Blk 3017, Bedok North St 5#03-26. Singapore 486121

Telephone 65-64813300 Fax 65-64495058

Sonya Liu MBA Executive Director Marketing & Sale

mailto: [sonya@drinkingvinegar.com](mailto:sonya@drinkingvinegar.com)



## Davis & Standard Twin Screw Extruder USA, Commercial

<b>Crop</b>	Wheat
<b>Residue</b>	Straw
<b>Process</b>	Fiberization, Reduction
<b>Equipment</b>	Twin Screw Extruder
<b>Main Product</b>	Wheat straw polypropylene composites used as agro plastic materials <sup>208</sup>
<b>By-Product</b>	Pelletized feedstock

### Technical Description of Technology<sup>209</sup> Twin Screw Extruder

- \* Modular co-rotating twin-screw extruder
- \* In-line compounding series
- \* Diameters from 20mm and larger
- \* Designed for research and/or continuous production
- \* Processing speeds up to 1800 RPM

### Detailed Process Description<sup>210</sup>

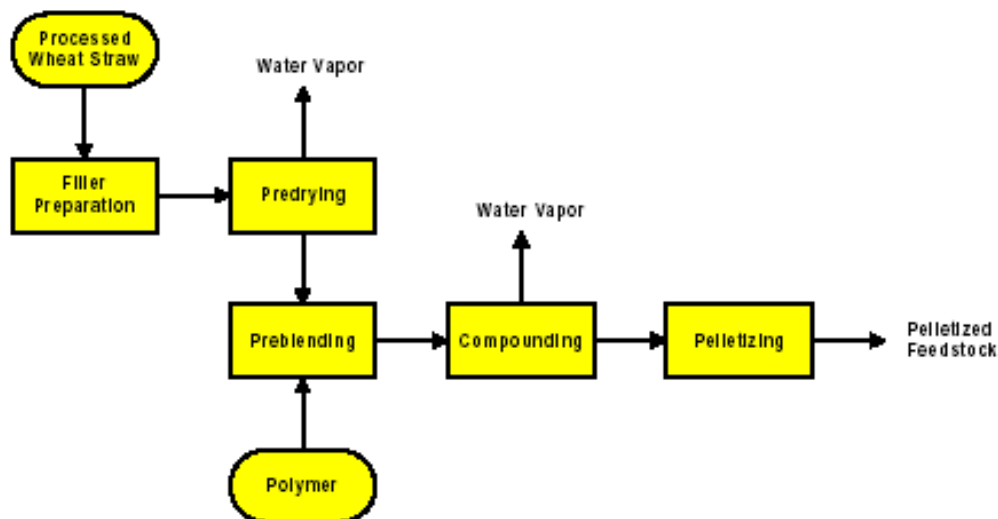

Figure 1. General Schematic of the Compounding Process

<sup>208</sup> <http://www.agroplastics.com/biomass.pdf>

<sup>209</sup> [http://www.davis-standard.com/public\\_html/products/compounding.html](http://www.davis-standard.com/public_html/products/compounding.html)

<sup>210</sup> <http://www.fpl.fs.fed.us/documnts/pdf1997/johns97b.pdf>

All of the composite blends were compounded in a Davis & Standard (Pawcatuck Conn.) twin-screw extruder. The extruder has 32-mm diameter co rotating intermeshing segmented screws with a length-to-diameter ratio of 32:1. There are eight electrically heated, water-cooled barrel sections, two that have vents for removing volatile materials. Power is supplied by a 15-hp DC drive, and a four-hole strand die is fitted to the discharge end. The machine's capacity is 45 kg (100 lb.) of unfilled polypropylene per hour.

The extruded strands of wheat straw/polypropylene composites were cooled in a water slide trough and then pelletized in a Cumberland (Providence, R.I.) pelletizer. A flow diagram of the process is shown in Figure 1.

The wheat straw was processed using different fiberization and size reduction technologies. Pinnacle has developed two grades of 30 percent wheat straw/70 percent polypropylene for market (WS-01 and WS-02). In addition, a third grade has been developed which is 30 percent wheat straw/70 percent polyethylene (WS-03). Prior to compounding, all the wheat straw samples were predried from ambient moisture content of 10 to 12 percent to approximately 1 percent. This predrying stage is critical before the compounding stage since excess moisture in the straw will produce steam. This causes the final pellet to foam and can trap moisture inside the pellet. Vacuum is applied to the vent zones of the extruder to remove the final 1 percent moisture and the final composite pellets are ready for further testing.

After the compounding stage and pelletizing, the blends were dried at 105°C from 2 to 4 hours and injection-molded into standard ASTM test specimens on a Cincinnati Millicron 33-ton reciprocating screwtype 33 molding machine. The screw diameter is 32 mm with a length-to-diameter ratio of 20:1 and a nozzle size of 3.12 mm.

### **Job Potential<sup>211</sup>**

The plants have all been designed for rural economic development. Each plant will employ 15 - 20 people and will be placed near the wheat straw to reduce shipping costs as well as provide the opportunity for well paying, manufacturing jobs in farming communities. This system can be a large economic boon to communities that are now struggling to provide non-farm jobs in order to support its citizens and increase their tax base.

### **Operation and Maintenance Requirements<sup>212</sup>**

Each manufacturing plant will produce 15 tons per operating day of polypropylene/polyethylene resin pellets containing up to 50% wheat straw. Total cost for the commercial facility system is \$2,000,000. Electrical power loads are 400 HP and natural gas loads are 3,800 SCFD for the facility.

---

<sup>211</sup> *ibid.*

<sup>212</sup> *ibid.*

### **Environmental and Social Considerations<sup>213</sup>**

This technology will provide farmers with large new markets for wheat straw. The farmers have currently found mechanisms to dispose of 530,000 tons of straw but need to find new uses for the remaining 750,000 tons. To help, the legislature passed SB2086 which provides a \$15 per ton tax credit for the purchase of rice straw (New Uses Council Newsletter, Spring 1997). This technology is an ideal candidate to assist in off-farm commercial uses of the fiber.

### **Investment and Operating Cost<sup>214</sup>**

Total cost for the commercial facility system is \$2,000,000. Electrical power loads are 400 HP and natural gas loads are 3,800 SCFD for the facility.

### **Advantages to Developing Countries<sup>215</sup>**

The Agro-Plastic manufacturing plants are designed for small communities, providing employment and non-farm revenues at a time when small rural communities are struggling with depressed crop prices and loss of manufacturing jobs. This will create additional income streams for rural areas, while reducing currently high waste disposal costs. This project will yield the following benefits:

- New cash crop for the producers by selling wheat straw or other agricultural residue
- High paying plastic's manufacturing jobs (approximately 25 - 30 per plant)
- Increased tax base

### **GHG Emission Reduction Potential<sup>216</sup>**

Agro-fibers have several advantages over traditional fillers, and they improve the general characteristics of the plastic. In general, the benefits of agro-plastics are as follows:

- Processing temperatures are reduced to less than 400°F, thus decreasing energy costs
- From initial test runs it appears that cycle time is reduced up to 25% (in one case cycle time was reduced 50% - from 2 minutes per piece to 1 minute per piece)
- Increased tensile and flexural strength compared to unfilled plastic
- When compared to standard fillers such as mica, calcium carbonate and talc, specific gravity is much lower thus less material is used to make each part
- Since each part weighs less, shipping costs are reduced
- Reduced wear and tear on molds

---

<sup>213</sup> *ibid.*

<sup>214</sup> *ibid.*

<sup>215</sup> *ibid.*

<sup>216</sup> <http://www.agroplastics.com/research/research.html>

## Examples of Real Life Applications

**Level of Use** Commercial Use  
**Name of Project** Davis & Standard Twin Screw Extruder  
**Location** USA

### Suppliers<sup>217</sup>

John Radovich  
Director of Extruder Technology  
Davis-Standard, LLC  
Tel (860) 599-6372  
Fax (860) 599-6258  
[jradovich@davis-standard.com](mailto:jradovich@davis-standard.com)

Agro-Plastics, Inc.  
619 East 8th Street, Suite D  
Lawrence, Kansas, 66044  
Tel: (785) 842-8684  
Fax: (785) 749-9214



---

<sup>217</sup> [http://www.davis-standard.com/public\\_html/productsafety/contactus.html](http://www.davis-standard.com/public_html/productsafety/contactus.html)

## **Details of Technologies**

### **2. Waste to Material Conversion**

#### **B. Technologies under pilot Testing**

## **Pearson Gasification Technology U.S.A., Demonstration**

<b>Crop</b>	Rice
<b>Residue</b>	Rice Straw
<b>Process</b>	Gasification
<b>Equipment</b>	Feeder, Gasifier, Cyclone
<b>Main Product</b>	Ethanol
<b>By-Product</b>	Ash, Alcohol, Water

### **Technical Description of Technology**

The Pearson process is a versatile process for converting biomass material to syngas and/or liquid fuel products by a combination of steam reforming (gasification) of solid feed and a F-T series of gas reforming steps. The specific design converts ground waste wood, sawdust or rice straw into fuel grade ethanol as its end product.

Wood or straw, as received, is dried to a moisture content of about 15%, and ground fine enough (~ 3/16") to be fed, along with superheated steam, into a gas-fired primary reformer. The reformer is externally heated, so that the product gas is not diluted by nitrogen from the combustion air. Air is also removed from the injected rice straw to minimize dilution of the syngas product with nitrogen. The organic material in the feedstock is efficiently gasified (>98% conversion efficiency), leaving only the inorganic materials (ash). The raw syngas then passes through a series of five different cleaning steps to remove any ash or tars (e.g. heavy hydrocarbons) that could be detrimental to downstream catalyst beds or processing equipment.

The clean gas is next compressed to a high pressure, and passed through the series of F-T reaction stages, where the ratio of H<sub>2</sub> to CO is adjusted to an optimum for reaction to ethanol. During this process, surplus H<sub>2</sub>, methane (CH<sub>4</sub>), and carbon dioxide (CO<sub>2</sub>) are separated using a Pressure Swing Absorption system (PSA) and recycled to appropriate points in the process. As a result, there are no by-product vent streams, so that up to 100% of the feed C content can be converted theoretically to syngas and or ethanol. The emissions are surplus water, mainly as clean vapor from the cooling steps. Multiple alcohols are produced and sent to a distillation column for separating the ethanol from methanol, water and other (higher molecular weight) alcohols. The final product is 95% ethanol, which can be run through a silica gel column to produce a 99% fuel grade ethanol.

## Detailed Process Description

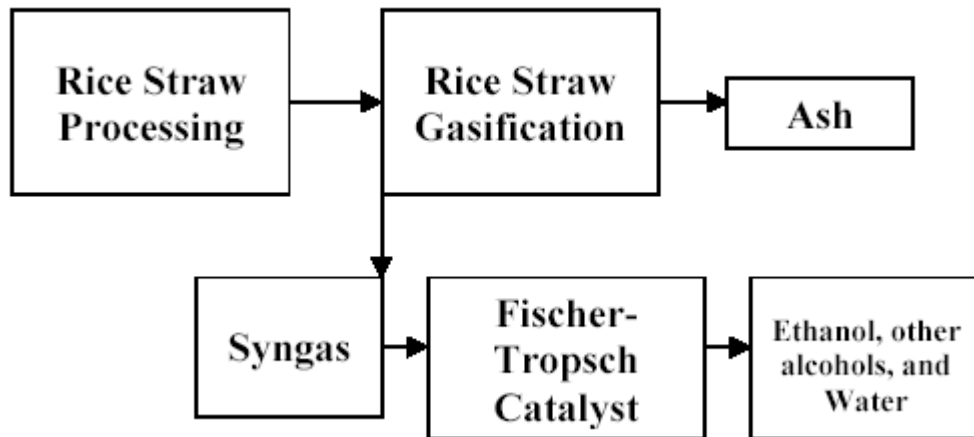

**Figure 1. Pearson Technology Process Flow Diagram**

The processed rice straw is injected into the gasifier/reformer with super-heated steam. The super-heated steam also contains some recycled water and other alcohols from storage tanks. The rice straw-feeding device is a commercially available unit that is complementary to Pearson's proprietary configuration of the gasifier.

The gasifier is indirectly heated by burning natural gas, so that the product gas is not diluted by nitrogen from the natural gas combustion product stream. The feeder, the gasifier and all downstream components operate at a pressure high enough to result in a substantial reduction in the size of piping, vessels and other components. Silica, metal oxides, traces of elemental C and higher molecular weight hydrocarbons are collected as ash.

The hot, raw syngas is cooled in the steam production/heat recovery system and the recovered heat is used to produce super-heated steam and lower-grade heat for drying the rice straw. The partially cooled gas then passes through a cyclone to remove particles that are greater than 5-10  $\mu\text{m}$  in size and then through a High Efficiency Particulate Air (HEPA) filter to remove particles down to about 0.5  $\mu\text{m}$ . It then passes through a counter-current water scrubber where water-soluble components are removed. The cooled syngas gas is further cleaned by scrubbing with a circulating stream of light petroleum oil, which absorbs BTX and heavier hydrocarbons that may have been formed during gasification. A small amount of oil is periodically sent to the gasifier to keep the oil from becoming saturated with BTX and higher molecular weight hydrocarbons. At this point, the clean, dry gas is about half  $\text{CO}_2$  by weight, the rest being a mixture of  $\text{H}_2$ ,  $\text{CO}$ , methane and ethane.

It is not possible that the F-T catalyst could produce a single product (ethanol in this case) with one pass. Therefore, in order to increase the yield of ethanol, it is necessary to separate the products (methanol) by distillation and re-introduce the methanol with the  $\text{H}_2$  and  $\text{CO}$  at the compression stage. According to the Pearson team, the nearly complete conversion of the methanol to ethanol may require recycling up to 7 or 8 times.

These products are cooled and collected in a condenser and fractionated using a distillation column into three fractions: 1) methanol, 2) ethanol (95%) and an aqueous solution of the remaining alcohols. The excess H<sub>2</sub> and CO is separated from the aqueous phase and recycled back to the compressor.

The flow diagram shows no water entering the process except for the moisture in the rice straw. Recycled water, condensed from the various process streams, appears to be adequate to generate the steam needed. However, there are also some cooling water requirements not shown, and all or most of the water will be combined at a cooling tower, where most of the excess process heat will be rejected, with substantial evaporation losses. Thus a small but highly variable supply of make-up water will be available if required.

### **Main Products**

Ethanol

### **Environmental Considerations**

The overall process used standard chemical engineering design practice from the chemical industry, to maximize recovery of excess heat and generate the required steam, minimizing natural gas consumption. A proprietary design for the gasifier resolves earlier problems with indirect feed heating, provides the heat of reaction to convert wood (cellulose and lignin) to syngas, without having to burn the wood or straw and dilute the syngas with nitrogen. This, plus pressurized operation, results in smaller gas volumes and much smaller equipment. Even though this results in higher unit costs of high-pressure vessels and piping, the overall effect is lower total equipment costs. Another critical design feature is the use of multiple, redundant gas cleaning operations, to protect the downstream systems (e.g. catalysts) in the event of gasifier malfunctions.

### **Investment and Operating Cost**

The increasing costs of natural gas and electricity suggests that further evaluations of the tradeoff in using part of the syngas to produce electricity and or process steam and heat should be conducted to determine if it is more cost effective.

The F-T catalyst is expensive and the lifetime of this catalyst needs to be evaluated over sufficient periods of operating time. Pearson is continuing to run the rice straw derived syngas to better evaluate catalyst deterioration.

The major economic driver appears to be cost of raw material. The syngas derived from rice straw and wood waste showed negligible differences in chemical composition when compared on an ash-free and moisture free basis. Since the delivered cost of rice straw is typically higher than some forms of wood wastes, it is recommended that further economic and



operational analysis be carried out to determine the benefits of mixing wood waste with rice straw.

### **Examples of Real Life Applications**

The Demonstration Plant is be located in the recently developed City of Gridley Industrial Park in Gridley, California (“Gridley”).

### **Sources:**

5. <http://www.nrel.gov/docs/fy05osti/37581.pdf>

## **Silo-based Composting Technology Philippines, Pilot**

<b>Crop</b>	Agricultural crops
<b>Residue</b>	Agricultural waste
<b>Process</b>	Composting
<b>Equipment</b>	hopper/feeder and crusher, conveyor system, shredder, mixer, silo, etc.
<b>Main Product</b>	Fertilizer
<b>By products</b>	

### **Technical Description**

#### **Composting Technology**

The Baguio composting facility is originally designed to cater approximately 20 tons of biodegradable wastes generated daily by the city. To meet this kind of demand, a composting technology should be appropriate, sound and innovative. After initial scanning and validations sometime in 1999, the stakeholders of the composting project agreed to set – up a silo-based composting plant for a biodegradable waste-rich city. Various composting equipment (i.e. hopper/feeder and crusher, conveyor system, shredder, mixer, silo, etc.) comprises the plant.



Figure 1. Baguio Composting Facility

Limited space, volume of biodegradable wastes, temperature, capacity, and design are all considered in the selection of the technology. Moreover, the innovations for the technology make it a one-of-a-kind and the first ever to be tested and made operational in the Philippines.

#### **Detailed Description Process**

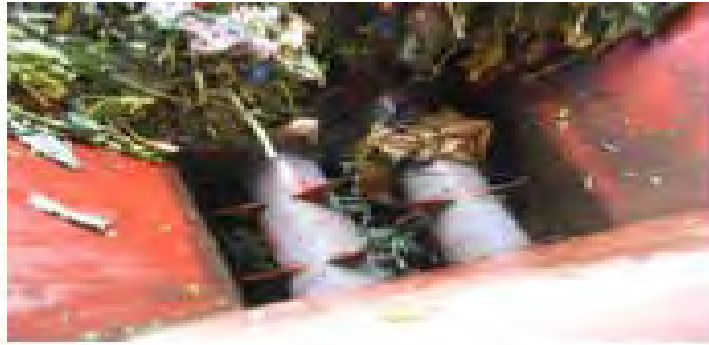

Figure 2. Hopper or Feeder

The composting technology starts with the hopper or feeder where the bulk and sacked vegetable wastes from the market are all dropped before being crushed by the crusher. A belt conveyor catches and slowly transmits horizontally the slightly crushed vegetables into the shredder. One personnel applies the dry mass to the vegetable wastes, becoming the primary substrates for composting, while being transported to the hopper of the shredder. The dry mass is intended to (1) absorb moisture from the vegetable wastes, since 80-90% of the wastes' composition is liquid, and (2) create a balance between the nitrogen and carbon elements. The shredder further breaks the substrates into smaller pieces to expose more surface area for decomposition. Shredded substrates are hauled into the mixer by the screw conveyor linked between the two.



Figure 3. Enhanced microorganisms are added to hasten digestion

An inoculant, enhanced microorganisms released from a supply tank on top of the mixer, is fused with the substrates resulting to secondary substrates to hasten digestion. These secondary substrates are now ready for the aerobic process of composting. The substrates exit the mixer and are brought up to the silo through a bucket conveyor. All equipment is run by a three-phase electrical layout. In usual practice for a silo-based composting, peak of decomposition usually takes a minimum of 30 days to be fully composted (for thermophilic phase). With this in mind, the silos, intended to take care of the volume requirement of vegetable wastes and space considerations, are designed also to shorten the decomposition time and control the temperature for composting vis-à-vis the Baguio climate. It is projected to a 20 to 25 days decomposition time only, ready for curing and maturity stage before sieving and packaging. Although the composting plant produces a competitive

compost quality, it only produces on a small scale. This is due to the additional functions built on the silo to meet the adjustments on the composting process that did not materialize aside from other equipment inefficiencies.

### **Advantages to Developing Countries**

In the Philippines, despite the various local and national legislations related to waste management, composting activity remains marginal as most Filipinos do not have strong orientation on this type of waste management strategy. Indeed, of the 150-400 tons of waste being generated daily in major cities in the Philippines, 50% are biodegradable. Moreover, it is saddening that only 10% of these biodegradable wastes are collected and processed. The remaining 90% of these wastes are either hauled to dumpsites or dumped illegally to private lands, rivers and creeks. The catastrophic garbage slide incident that happened in Payatas dumpsite in Metro Manila in 2002, which killed more than 200 people living in the dumpsite, best describes how worst the waste management program in the Philippines.

### **Example of Real Life Applications**

Baguio City Philippines

#### **Supplier:**

Baguio City Hall  
2600 Baguio City, Philippines  
**Tel. Number:** (063)(074) 446-4460  
**Fax Number:** (063)(074) 442-8931  
**Email:** webmaster@baguio.gov.ph



Figure 4. Bio Soil Product from Composting

#### **Sources:**

1. [http://www.fssi.com.ph/index2.php?option=com\\_docman&task=doc\\_view&gid=20&Itemid=61](http://www.fssi.com.ph/index2.php?option=com_docman&task=doc_view&gid=20&Itemid=61)

## **Broin Fractionation (BFRAC)<sup>218</sup>** **USA, Pilot**

<b>Crop</b>	Corn, Switchgrass, wood
<b>Residue</b>	corn stalks, switch grass, wood chips
<b>Process</b>	Corn fractionation and Lignocellulosic Conversion Technology
<b>Equipment</b>	Bio-refinery plant
<b>Main Product</b>	Ethanol
<b>By-products</b>	Value-added co-products, including Dakota Gold HP (TM), Dakota Bran (TM) Cake, and Dakota Gold Corn Germ Dehydrated (TM) that is being further processed to create defatted corn germ meal and edible corn oil. <sup>219</sup>

### **Technical Description of Technology:**

The process uses enzymes that convert starch to sugar without cooking. Here's how it works.

**Milling.** The feedstock passes through a hammer mill, which grinds it into a fine powder called flour.

**Fermentation.** Fermentation: Enzymes are added to convert starch into glucose, or simple sugars. Yeast is added to the mash to convert the sugars to ethanol and carbon dioxide. The mash is continually agitated and cooled until the ethanol concentration has been maximized.

**Distillation.** Distillation: The fermented mash, now called beer, contains about 20% alcohol – significantly above the industry standard - plus all the non-fermentable solids from the corn and yeast cells. The mash is pumped to the continuous flow, multi-column distillation system where the ethanol is removed from the solids and the water. The ethanol leaves the top of the final column at about 95% concentration, and the residue mash, called stillage, is transferred from the base of the column to the co-product processing area.

**Dehydration.** The alcohol from the top of the column passes through a dehydration system where the remaining water will be removed. Most ethanol plants use a molecular sieve to capture the last bit of water in the ethanol. The alcohol product at this stage is called anhydrous ethanol (pure, without water) and is approximately 200 proof.

---

<sup>218</sup> <http://www.poetenergy.com/learn/process.asp>

<sup>219</sup> <http://www.allbusiness.com/legal/intellectual-property-patent/1045974-1.html>

Co-Products. There are two main co-products created in the production of ethanol: distillers grain and carbon dioxide. Distillers grains are a highly nutritious livestock feed. Dakota Gold brand dried distillers grains meets a higher level of nutritional content and physical consistency than is possible with any other biorefining process.

Carbon dioxide is also a natural result of fermentation. A select few of the plants collect compress and market it for use in other industries. The carbon dioxide it produces is ultimately reabsorbed by future corn crops, which need CO<sub>2</sub> to grow.

### **Detailed Process Descriptions:**<sup>220</sup>

BFRAC has been described as a biorefining revolution for the ethanol industry. It separates the corn into three fractions including fiber, germ and endosperm. The endosperm is then fermented to create ethanol while the remaining fractions are converted into new value-added co-products, including POET's trademarked Dakota Gold HP (a high protein distillers grain feed product), the trademarked Dakota Bran cake, corn germ meal and corn oil. In addition to these high value co-products, the process also results in increased plant throughput and decreased energy consumption.

### **Main Products:**

Value-added co-products, including Dakota Gold HP(TM), Dakota Bran(TM) Cake, and Dakota Gold Corn Germ Dehydrated(TM) that is being further processed to create defatted corn germ meal and edible corn oil.

### **Social Considerations**<sup>221</sup>

The National Corn Growers Association has estimated that that approximately 15 billion gallons of ethanol can be produced from corn without giving up the existing domestic and export markets. Additionally, they point out that ethanol's co-product, a high-protein animal feed called distillers grains, will displace more than one billion bushels of corn for feed per year starting in 2008.

### **Investments and Operating Cost**<sup>222</sup>

The project is being built by Broin Companies, a dry mill ethanol producer, which has applied for matching grant funds through the U.S. Department of Energy (DOE) to assist with the \$200 million expansion.

Because cellulosic ethanol requires not one but three processing facilities--an ethanol distillery, a pretreatment facility and a power generation plant, a commercial-scale enterprise is expected to cost from \$350 to \$400 million, or roughly six times the cost of a corn (dry mill) ethanol plant of the same scale.

### **Economic Instruments for Overcoming Barriers**<sup>223</sup>

---

<sup>220</sup> <http://www.poetenergy.com/learn/bfrac.asp>

<sup>221</sup> <http://www.poetenergy.com/learn/foodandfuel.asp>

<sup>222</sup> <http://www.renewableenergyworld.com/rea/news/story?id=46636>

<sup>223</sup> <http://www.allbusiness.com/legal/intellectual-property-patent/1045974-1.html>

Collaboration with other companies such as Satake Corporation from Japan to provide the equipment necessary to make BFRAC possible. Broin was able to negotiate a long-term exclusive with Satake for the equipment developed through collaboration. Also, the Department of Energy's National Renewable Energy Laboratory (NREL) has partnered with private biotech companies to make important advances in conversion technology.

### **Advantages to Developing Countries<sup>224</sup>**

The process not only reduces energy costs, but also releases additional starch content for conversion to ethanol, increases protein content and quality of byproducts, increases byproduct flowability, potentially increases plant throughput, and significantly decreases plant emissions.

---

<sup>224</sup> <http://www.allbusiness.com/legal/intellectual-property-patent/1045974-1.html>

## High Capacity Coco Coir Twining<sup>225</sup> Philippines, Pilot Demonstration

<b>Crop</b>	Coconut, Pina, and Abaca
<b>Residue</b>	Coconut, Abaca and Piña Fibers
<b>Process</b>	Twining
<b>Equipment</b>	Coir Twining Machine
<b>Main Product</b>	Coconut, Abaca and Piña Twines

### Technical Description of Technology

Parts: Feeder/Conveyor, Twining Assembly, Spool Assembly, Transfer Mechanism, Prime Mover

### Detailed Process Description

This machine is designed and fabricated to meet the growing demand for coconut fiber twines that will be used in the production of erosion control geotextile net.

The equipment produces 4-6 mm diameter two-ply rope by intertwining the fibers, is powered by a 2 Hp motor that drives the combination of pulleys and gear mechanism. It is believed to attain the optimum condition and performance of the machine by employing speed control vis-a-vis quantity and volume of fibers coming from the conveyor, i.e., doubling the capacity and improving the fiber strength.

The expected capacity of the equipment is 4 kg/hr or 32 kg/day. The machine produces 32 kg/day of twined fibers than the conventional machine that produces about 18-20 kg/day only. The increased capacity could be attributed to the introduction of the improved spindle/spool mechanism that reduces the production cycle by almost half. The conventional machine spools the fiber and the spooled yarn has to be transferred to a separate machine for rewinding. The improved twining equipment will do both functions as MIRDC engineers designed a flexible and collapsible spindle/spooler mechanism to serve that purpose. Equally important feature of the machine is the provision of variable speed, using a variable pulley mechanism or a frequency inverter, to allow the machine to twine not only coco coir but also other fibers like abaca, piña, etc. This flexible feature of the equipment makes it user friendly and can be operated by a beginner or an experienced one.

### Operation and Maintenance Requirements

REVENUE 20 kg/day x 22days/mo. x 12 mos.x Php 45/kg = Php  
237,600

---

<sup>225</sup> <http://www.mirdc.dost.gov.ph/cocoCoir.htm>



**NET INCOME**

Before Tax = 237, 600 – 141, 593 = Php 96,007

After Tax = 96,007 (1-0.32) = Php 65,284.76

PAYBACK PERIOD = 150,000/65,284.76 = 2.3 yrs.  
PROJECT ROI = 65,284.76/150,000 = 43.5%

**Social Considerations**

With the introduction of the improved twining mechanism and spool assembly, the equipment will have the following impact:

- a) Increased number of employment in coco coir processing plant
- b) Increased production of coco twines
- c) Increased production of geo-textile in terms of square meter capacity per day
- d) Increased number of satellite coco coir plants in different regions of the country
- e) Increased revenue (net income) per year due to higher productivity and better quality of coco coir products.

**Investment and Operating Cost**

Investment Cost:

Equipment					Php
145,000					
Motor	(2	hp,	1	phase)	
<u>5,000</u>					
			Sub total		Php

150,000  
Manufacturing Cost

**Fixed Cost per Year**

800	Salaries and Wages (1 person at 200/day)	Php 52,
000	Depreciation	15,
<u>280</u>	Overhead cost (10% of salaries and wages)	<u>5,</u>
	Sub total	Php 73,

080	Material Cost P 8.50 (card fiber) x 20 x 22 x 12	44,
880	Electricity 2 Hp x .746 x 8 x 22 x 12 x P7.5/kw-hr	23.
633		
-----		-----
	Sub total	Php

68,513  
Total Manufacturing Cost      Php 141,593

## **Economic instruments for overcoming barriers<sup>226</sup>**

Soft loan facility for the Coconut Commodity Development Project (CCDP) of the Philippine Coconut Authority (PCA) for procurement of machinery and equipment needed to put up activated carbon and coco coir processing facilities like decorticating machines and twining machines for fiber and geotextile processing.

### **Advantages to Developing Countries**

The high capacity twining machine is expected to meet and sustain the increasing demand of twines and geo-textile net both local and abroad. There is a huge demand of coco based geo-textiles in China as it embarks on a ground beautification campaign in preparation for its hosting of the 2008 Olympics.

- China is losing about 2,400 sq. kilometers of its land to desertification each year and needs the same size of geo-textiles to arrest the problem. That is estimated at 260,000 sq. kilometer now and concentrated mostly in the northern part, i.e., Beijing, Harbin among others.
- China's demand for mattress is 100 Million mattresses annually, that is, 37,500 tons of fiber per month or 450,000 tons of fiber per year. The Philippines exports capacity is only 3,000 tons of fiber per month.

### **Examples of Real Life Applications**

<b>Level of Use</b>	Demonstration Level
<b>Name of Project</b>	High Capacity Coco Coir Twining Machine
<b>Location</b>	Philippines

### **Suppliers**

RESEARCH AND DEVELOPMENT DIVISION  
Metals Industry Research and Development Center  
MIRDC Compound Gen. Santos Ave. Bicutan, Taguig, Metro Manila  
Tel. Nos. 837-0431 to 38 locals 330/332



<sup>226</sup> <http://www.newsflash.org/2004/02/be/be002752.htm>

## **Cornstalk Flash Volatilization USA, Pilot**

<b>Crop</b>	Corn
<b>Residue</b>	Stalk
<b>Process</b>	Volatilization
<b>Equipment</b>	automotive fuel injector
<b>Main Products</b>	Ammonia and synthesis gas

### **Technical Description of Technology:**

The researchers start with either pure soy oil or a thick sugar syrup. Using an automotive fuel injector, they spray the oil or syrup as fine droplets through a tube. Sitting like a plug in the tube is a porous ceramic disk made of a special catalyst material. As the droplets hit the disk-whose surface temperature is 1,000 degrees C-the heat and oxygen break apart the molecules of oil or sugar. The catalyst guides the breakdown toward the production of synthesis gas rather than toward water vapor and carbon. The synthesis gas passes through the porous disk and is collected downstream in the tube. No external heating is needed because the chemical reactions release enough heat to break up molecules of oil or sugar following in their wake.

### **Detailed Process Descriptions:**

The oil and sugar water are sprayed as fine droplets from an automotive fuel injector through a tube onto a ceramic disk made of a catalyst material--the elements rhodium and cerium--that guides the breakup of the feedstock molecules toward the production of syngas and away from water and carbon "gunk." Because the catalytic disk is porous, the syngas passes through it and is collected downstream in the tube. No external heat is needed, because the chemical reactions that produce syngas release enough heat to break up subsequent molecules of oil or sugar.

A difficulty in turning plant material into usable fuels has been breaking down the chemical bonds in cellulose--the material that gives plant cell walls their stiffness--to liberate simple sugars that can be fermented into ethanol or turned into other fuels. That requires special enzymes and lots of time. But the high heat of the new process breaks those bonds with ease, meaning cellulose and similar plant materials can possibly be used as feedstocks. The secret is ultrafast flash volatilization [vaporization] The work was supported by the Department of Energy and the University of Minnesota Initiative for Renewable Energy and the Environment.

## **Main Products:**

The process yields a mixture of hydrogen and carbon monoxide gases called synthesis gas, which is now used to make synthetic diesel fuel (dimethyl ether, also a substitute for propane gas) and ammonia, a constituent of fertilizer. Hydrogen is also the energy source for fuel cells and may someday be burned in car engines instead of fossil-based gasoline.

## **Operation and Maintenance Requirements:**

The new process works 10 to 100 times faster than current technology, with no input of fossil fuels and in reactors at least 10 times smaller than current models. The work could significantly improve the efficiency of fuel production from renewable energy sources. The researchers have produced just under half a kilogram of synthesis gas in a day using their small-scale reactor.

## **Social Considerations**

It's a way to take cheap, worthless biomass and turn it into useful fuels and chemicals. Potentially, the biomass could be used cooking oil or even products from cow manure, yard clippings, cornstalks or trees.

## **Advantages to Developing Countries**

The researchers used clean and refined products for their test; sugar water and soy oil. It is not clear how easy it will be to convert this technology to 'dirty' sources of fuel, such as wood chips or bio-waste that have more than just the reactants needed. The idea being tossed around is that because the temperature is so hot, you don't need to do the expensive and time consuming process of extracting the sugar (or oil) from the cellulose structure—instead the heat vaporizes the cellulose and the reaction can take place immediately, thus the incredibly fast production of fuels from waste products.

## **Examples of Real Life Applications**

University of Minnesota lab of Lanny Schmidt

## **Sources**

## Decentralized Wastewater Treatment System (DEWATS)<sup>227</sup> Philippines, Demonstration

<b>Crop</b>	Rice, etc.
<b>Residue</b>	Rice hull, scrap plastic water bottles, and other solid wastes.
<b>Process</b>	Decentralized Wastewater Treatment System (DEWTS)
<b>Equipment</b>	Plastic septic tank connected to an anaerobic reactor, an aerobic reactor, and an algal pond
<b>Main Product</b>	Low-cost decentralized wastewater treatment system (DEWATS)

### Technical Description of Technology:<sup>228</sup>

#### a) Technology from Trash



Trash Technology: These recycled plastic bottles contain biomass residues that can turn murky water into clean water.

#### b) Waste Treating Waste



<sup>227</sup> <http://www.adb.org/water/actions/PHI/using-solid-waste.asp>

<sup>228</sup> <http://www.adb.org/Documents/Events/2005/Sanitation-Wastewater-Management/paper-jose.pdf>

Small perforated plastic bottles with pyrolyzed rice hull (top) are placed inside larger perforated bottles (bottom) to form DEWATS' microbial support system.

### DEWATS Project<sup>229</sup>

The project is a form of decentralized wastewater treatment system (DEWATS) but it could also be part of a centralized system. It is about treating the effluent from septic tanks, which consists of an anaerobic filter, an aerobic attached film reactor, and an algal pond. The system from employs waste materials as components, which may lower the cost. Septic tanks made from recycled plastics are recommended. The anaerobic filter reactor can either made of waste plastics or concrete. It could be configured as upflow, downflow, or baffled reactor. The microbial support materials are made up of waste biomass residue (rice hull or coconut coir dust, as is or pyrolyzed and bound together by melted waste plastic). The aggregates are placed inside small perforated plastic bottles, which are in turn placed inside large perforated bottles (gallon sized mineral water bottles). The large bottles are stacked in the anaerobic tank. The support structures are made of waste plastics.

Figure 1. Anaerobic filter reactor

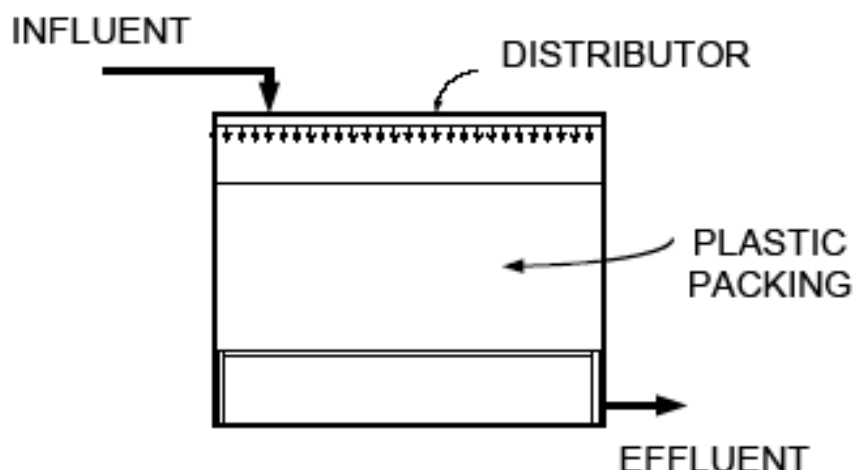

The aerobic attached film reactor is similar to the anaerobic tank. It is also provided with microbial attachment system made of waste plastic. Perforated mineral water bottles (400 to 600 ml, top and bottom cut open) are welded side-by-side standing up. Two small-perforated plastic bottles are placed inside. The small bottles contain cut corrugated sheets (used cell phone cards, aluminum cans, tetra-pak, etc.) Two assembled pieces occupy the space near the sides of the tank (25% of total volume).

Aeration is provided at the bottom of the elevated assembly. The structural support is made of recycled plastics. Using microbial support system is a form of process intensification. Since septic tank effluent is low strength wastewater, it cannot support and maintain the growth of free-floating microorganisms. The microbial support system provides the biofilms that

<sup>229</sup> <http://www.adb.org/water/actions/PHI/using-solid-waste.asp>

degrades the wastes. The algal pond has a lining, which could be made from waste plastics. This step can remove nitrogen and phosphorus nutrients from the wastewater. It increases the pH that can kill coliforms.

Figure 2 is an Aerobic attached film reactor that was constructed as a pilot-scale system consisting of an equalization tank, anaerobic filter reactor (volume = 1 cu m), aerobic attached film system (volume = 0.5 cu m), and a clarifier. This system was using wastewater from a banana chip manufacturing plant. (See Figure 3)

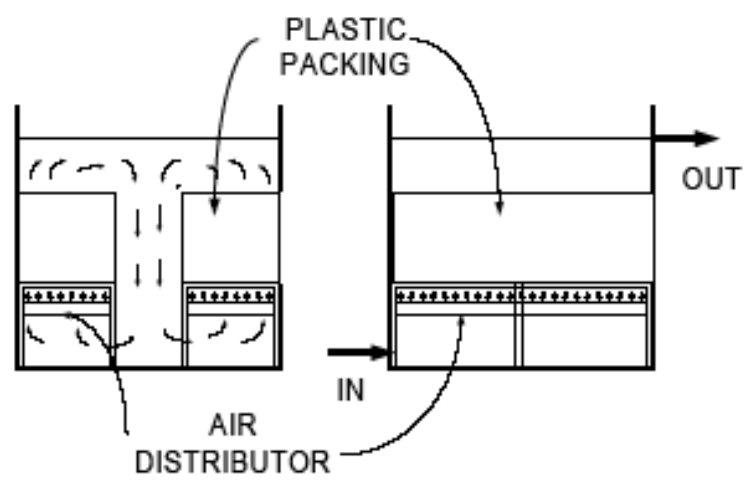

Figure 2 Aerobic attached film reactor



Figure 3 The pilot plant setup



### Detailed Process of Waste Treating Waste: <sup>230</sup>

The DEWATS is a plastic septic tank connected to an anaerobic reactor, an aerobic reactor, and an algal pond.

Septic tank effluent is filtered in the anaerobic and aerobic reactors—chambers where complementary chemical reactions take place to remove much of the wastewater’s filth. These chambers have “microbial support systems” that are capable of turning murky water into clean water.

The microbial support system for the anaerobic reactor consists of “pyrolyzed” waste biomass residue, and small and large perforated plastic bottles. Basically, the biomass residues, composed of rice hull or coconut coir dust that has undergone pyrolysis (a process of decomposition using heat), are bound together by melted waste plastic, and placed inside small perforated plastic bottles. These small bottles are then placed inside larger gallon-sized perforated bottles, and stacked in the anaerobic chamber.

Similarly, the microbial support system for the aerobic reactor uses solid wastes such as cut-up phone cards and aluminum cans, placed inside small perforated plastic bottles. They are then placed inside larger perforated plastic bottles, and lined-up near the tank’s inner walls. Low-cost blowers or air pumps at the bottom of the tank improve the water’s physical and chemical make-up through another process called aeration.

Clear water coming from these reactors is then discharged into the algal pond, lined also with waste plastics, to remove nitrogen and phosphorus nutrients, and increase the water’s pH-level to eliminate coliforms.

DEWATS Treatment Efficiency					
No	Parameter	Unit	Anlytical-Results Inlet	Outlet	Reduction [%]
1	Temp.	°C	27	27	–
2	pH	–	7,6	7,3	4 %
3	BOD 5	mg/l	290	53,6	83 %
4	COD	mg/l	590	84	86 %
5	Phosphate	mg/l	18,33	3,67	80 %
6	TSS	mg/l	172	84	51 %
7	Ammonia	mg/l	0,19	0,07	63 %

Source: Graha Asih Hospital Bali, Anaerobic Filter + Horizontal Sandfilter + Purification Pond

<sup>230</sup> Ibid.



**Job Potential:**<sup>231</sup>

Preparing the solid waste materials in usable form—perforating plastic bottles, processing biomass residues, and generally constructing the DEWATS—proved to be painstaking tasks for the project team. “But for small communities, where processing areas for waste materials can be established, the DEWATS can be easily replicated and could become a source of community livelihood,” the project team recommends.

**Social Considerations**<sup>232</sup>

1. Establishing of multi-stakeholder networks to combat water pollution
2. Building up implementation capacity on various levels
3. Providing treatment for both, domestic and industrial wastewater at affordable price
4. Fulfillment of discharge standards and environmental laws
5. Wastewater pollution reduced by up to 90%
6. Providing treatment for wastewater flows up to 1000 m<sup>3</sup> / day

**Economic Instruments for Overcoming Barriers**<sup>233</sup>

The project, under the ASEAN University Network-South East Asia Engineering Education Network (AUN/SEED NET), is funded by the Japan International Cooperation Agency (JICA).

**Advantages to Developing Countries**<sup>234</sup>

The state-of-the-art technology at reasonable costs, resulting from the use of local materials, has made DEWATS applications popular in the developing world.

The system costs less than conventional septic tanks, and can last for many years. It can be used for both centralized and decentralized systems, as it can easily be reinstalled in other sites. More importantly, it solves both the wastewater management problem and the problem of solid waste disposal.

**Disadvantages to Developing Countries**<sup>235</sup>

One drawback of the DEWATS is that it is not large enough. The pilot-scale system could only treat one cubic meter of wastewater at a time. The septic tank would also require de-sludging every two or three years. While the technology is sound, low-cost, and durable, however, there is another downside to the DEWATS.

**Example of Real Life Applications**<sup>236</sup>

The project aims to solve sanitation problems and environmental pollution caused by improper sewage disposal using a low-cost decentralized wastewater treatment system (DEWATS). DEWATS treatment efficiency for a hospital wastewater is found below.

---

<sup>231</sup> Ibid.

<sup>232</sup> [http://www.borda.de/conrat/Dewats\\_Mai05\\_72.pdf](http://www.borda.de/conrat/Dewats_Mai05_72.pdf)

<sup>233</sup> <http://www.adb.org/water/actions/PHI/using-solid-waste.asp>

<sup>234</sup> Ibid.

<sup>235</sup> Ibid.

<sup>236</sup> <http://www.up.edu.ph/upnewsletter.php?issue=28&i=414>

Dr. Wilfredo Jose, a professor of chemical engineering specializing in biotechnology at the UP Department of Chemical Engineering (DCE), is working through intensive research on a type of decentralized wastewater treatment system (DEWATS).

**Supplier:**

BORDA Head Office Germany  
fon: + 49 (0) 421 – 137 18  
e-mail: [office@borda.de](mailto:office@borda.de)  
[www.borda.de](http://www.borda.de)

## **Details of Technologies**

### **2. Waste to Material Conversion**

#### **C. Technologies under laboratory Testing**

## **The Philippine Carabao as a model for Cellulosic Ethanol Production Philippines, Research**

<b>Crop</b>	Rice Straw
<b>Residue</b>	Waste from rice straw
<b>Process</b>	Fermentation
<b>Equipment</b>	Autoclave, incubator, fermenters, densitometer, refractometers, refrigerated centrifuge, ultralow freezer
<b>Main Product</b>	Cellulosic ethanol

### **By-Product**

### **Technical Description of Technology**

The Philippine carabao is known for its ability to subsist on low quality forage, including rice stubbles and straw. This ability is bestowed on the animal by rumen microorganisms that digest complex carbohydrates, turning them into methane, CO<sub>2</sub> and Volatile Fatty Acids. Methane and CO<sub>2</sub> are expelled when the animal eructates while VFAs are parceled between the host animal and microorganisms. Rumen microorganisms metabolize glucose differently from most life forms. Instead of breaking complex carbohydrates to glucose or pentose, rumen microorganisms hydrolyze them farther into 1,2,3 and 4 carbon molecules, then, in a remarkable way, re-synthesize them to glucose. The Philippine carabao points out to a system that could simplify biomass ethanol production.

### **Detailed Description of the Technology**

Rice straw chopped to 10 mm size will be studied using the standard Central Luzon State University protocol for bioethanol production under two temperature conditions: room and sun-exposed. For each variable, 1 kg of substrate will be incubated with 20 grams urea and 100 ml of rumen fluid in 4L of tap water for 7 days, then pasteurized and/or sonicated and yeast fermented for another 7 days, at the end of which shinglings will be obtained to determine ethanol yield. Alcohol potential based on sugar will be determined at each fermentation stage to calculate conversion efficiencies under both conditions.

### **Main Products:**

Cellulosic Ethanol

## **Operations and Maintenance Requirements:**

Physical reduction of particle size (10mm) of the rice straw residues prior to hydrolysis is needed. Urea and molasses are added in the bioreactor along with rice straw residues and inoculated with 1% strained rumen fluid. Carbon dioxide gas was bubbled in for 5 minutes to render the solution anaerobic and stable at 6.8 to 7 pH. Latex balloons were placed on top of the narrow mouth of the bioreactor to allow emitted gases to go in and out of the balloon through the incubation period. The bioreactors were mechanically agitated for ten minutes, twice a day.

## **Social Considerations:**

This novel process could make possible the biomass ethanol conversion of 13 million metric tons of rice straw from 4,046,318 hectares of land devoted to rice farming in the Philippines each harvest season. It has been estimated that burning rice straw and sugar cane produces atmospheric pollution equivalent to burning 13 million barrels of oil annually. This new process of biomass ethanol production can provide farmers with a source of income and stop the practice of burning crop residues.

## **Advantages to Developing Countries**

Information of microbial growth patterns using CLSU model will be useful in determining the optimum duration of fermentation. Although microbial organisms can grow prodigiously, they reach a certain point at which they cannibalize each other or start consuming desirable end products such as sugars and ethanol at a greater rate than they produce from the substrate. It is therefore essential that the process can be terminated at a pre-determined peak population density consistent with maximum sugar and ethanol production.

## **Examples of Real Life Applications**

Philippine Institute of Graduate Studies  
Central Luzon State University  
Science City of Munoz, Nueva Ecija

Nutrition Laboratory  
Philippine Carabao Center  
Science City of Munoz, Nueva Ecija

**Country:** Philippines

**Level of Use:** Research

## **Sources:**

P.C. Florendo and F.B. Abenes, Institute of Graduate Studies, Central Luzon State University.

## BTL (Biomass-to-liquid) Technology USA, Research

<b>Crop</b>	Corn, Sugar cane
<b>Residue</b>	Corn stover, bagasse
<b>Process</b>	Syntec Process
<b>Equipment</b>	Scrubber, phase separator, alcohol synthesis reactor
<b>Main Products</b>	Ethanols and Bio Alcohols

### Technical Description of Technology:

The Syntec Process has the potential to revolutionize the ethanol industry with higher ethanol yields and lower production costs per ton of feedstock than any other ethanol production path in use today. Furthermore, it is anticipated that the Syntec Process will enable the conventional ethanol industry to value add by using these well established chemical processes to obtain production and efficiency metrics beyond which traditional grain based fermentation processes can offer.

### Ethanol From Carbonaceous Gas

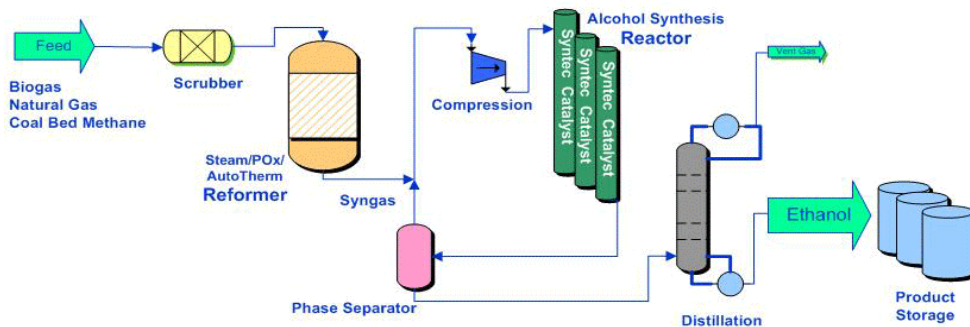

### Ethanol From Solid/Liquid Carbonaceous Material

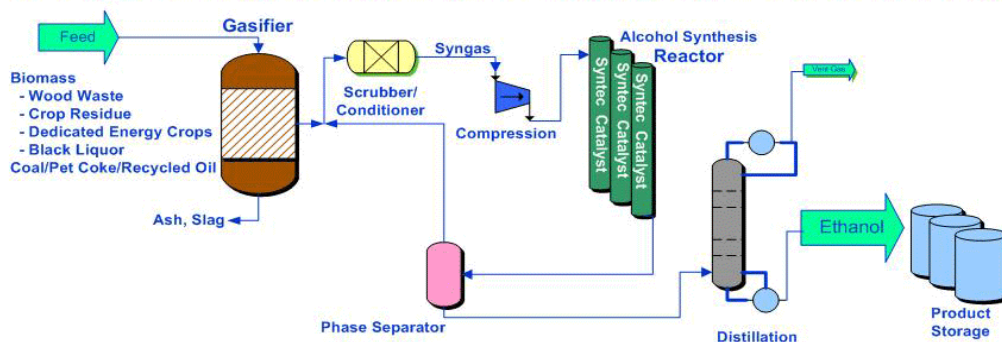

## **Detailed Process Description**

There are 3 basic steps in the Syntec Process:

4. production of syngas (CO, H<sub>2</sub>) either through the gasification of biomass feedstock, or through steam reforming/partial oxidation of biogas or landfill gas,
5. conversion of syngas to bio-alcohols over Syntec catalyst in a fixed bed reaction unit,
6. separation and purification of bio-alcohols (high purity) to ethanol, methanol, n-propanol and n-butanol.

**Main Products:** Ethanols and Bio Alcohols

## **Social Considerations**

Unlike petroleum-based fuels, biofuels are made from an unlimited renewable resource base which makes them one of the cleanest ways to mitigate carbon dioxide, carbon monoxide, particulate and other green house gas emissions associated with global transportation.

Ethanol contains 35% oxygen by volume, is biodegradable, non-toxic and carbon neutral, however, the true ethanol superstar would be that which is made from renewable and renewable waste resources. Ethanol derived in said fashion holds the potential of dramatic environmental benefits on order of magnitude greater than any other biofuel production path save perhaps biodiesel made from algae

## **Investments and Operating Cost**

Syntec has undertaken to raise up US\$3 million dollars to ramp up technical staff, purchase equipment and provide working capital for development, testing and quantifying the life of the catalysts prior to commercialization. Syntec's yield is equivalent to revenues in excess of \$27 million per year for a 300 ton per day biomass processing facility.

## **Advantages to Developing Countries**

Perhaps the most important aspect of the Syntec Process is the ability to convert abundant, low cost (sometimes negative cost) waste products into ethanol and bio-alcohols without harming the agricultural land base or competing with consumable food stocks. These green biofuels significantly reduce green house gas emission. Moreover, enough biomass exists and is renewed every year in North America, and other parts of the world, to significantly reduce a country's dependence on imported oil required for petroleum derived fuels.

## **Disadvantages to Developing Countries**

This source of biomass comes from the leftover organic material from crop harvesting. corn stover, rice straw, and bagasse are all examples of agricultural residues. Presently, some residues are used as animal feed, but there are still significant surpluses in many regions. While using agricultural residues may present a logistical problem and supply may become a problem due to their seasonal availability.

### **Examples of Real Life Applications**

University of British Columbia  
The University of British Columbia  
2329 West Mall Vancouver, BC Canada V6T 1Z4  
tel 604.822.2211 (Directory Assistance) |

### **Supplier**

#### **SYNTEC BIOFUEL INC.**

Phone: 604-648-2092

Email: [info@syntecbiofuel.com](mailto:info@syntecbiofuel.com)

### **Sources:**



## Biochar<sup>237</sup> USA, Research

<b>Crop</b>	Biomass
<b>Residue</b>	Waste
<b>Process</b>	Pyrolysis <sup>238</sup>
<b>Equipment</b>	Oxygen-excluding furnace
<b>Main Product</b>	Biochar for soil amendment

### Technical Description of Technology

Biofuels and bioenergy are often presented as 'carbon-neutral' because the carbon dioxide emitted by their use is taken up again as new energy crops grow. Like wind or solar power, they do not add CO<sub>2</sub> to the atmosphere. But the bioenergy community has long gone beyond this concept and has begun looking at the production of carbon-*negative* fuels and energy instead. These do not merely avoid new emissions from entering the atmosphere, they effectively take CO<sub>2</sub> *from the past* out of the atmosphere.

Carbon-negative bioenergy can be obtained via two ways: a high-tech and a low-tech process. The high-tech pathway involves transforming biomass into energy and fuels, while capturing the CO<sub>2</sub> and sequestering it in its gaseous form into geological sites such as depleted oil and gas fields, unminable coal seams or saline aquifers. They draw on 'carbon capture and storage' (CCS) techniques currently being developed by the coal industry.

The low-tech route consists of transforming biomass into useable fuels while keeping part of the carbon locked into an inert form, called biochar ('agrichar'). This biochar is then simply added to agricultural soils, in which the carbon can be sequestered safely for hundreds, possibly thousands of years. The discovery of ancient 'terra preta' soils demonstrates that carbon effectively remains locked up for a very long period of time.

### Specific Considerations for Developing Countries

The great advantage of biochar is the fact that the technique can be applied world-wide on agricultural soils, and even by rural communities in the developing world because it is relatively low tech. It is hoped that at the upcoming UNFCCC summit in Bali, experts will include biochar as a strategy to fight climate change that would be eligible for carbon credits under the Clean Development Mechanism.

### Environmental Considerations

---

<sup>237</sup> <http://biopact.com/2007/10/towards-carbon-negative-bioenergy-us.html>

<sup>238</sup> <http://www.sciencedaily.com/releases/2007/05/070511211255.htm>

More and more research shows that soils amended with the char have very beneficial effects on crop growth. The enhanced nutrient retention capacity of biochar-amended soil not only reduces the total fertilizer requirements but also the climate and environmental impact of croplands.

Char-amended soils have shown 50 - 80 percent reductions in nitrous oxide emissions and reduced runoff of phosphorus into surface waters and leaching of nitrogen into groundwater. As a soil amendment, biochar significantly increases the efficiency of and reduces the need for traditional chemical fertilizers, while greatly enhancing crop yields. Experiments have shown yields for some crops can be doubled and even tripled

### **Institutional and Regulatory Consideration or Requirements**

The biochar concept has meanwhile received formal political support. In order to speed up biochar research the U.S., Colorado's Senator Ken Salazar (D) recently introduced ['The Salazar Harvesting Energy Act of 2007'](#) [\*.pdf], focused on carbon-negative bioenergy production. The bill (S.1884) is awaiting discussion in the Senate Agriculture, Nutrition and Forestry Committee.

### **GHG Emission Reduction Potential**

Char-amended soils have shown 50 - 80 percent reductions in nitrous oxide emissions and reduced runoff of phosphorus into surface waters and leaching of nitrogen into groundwater.

Biochar thus offers the promise of carbon-negative biofuel production sustained by a cycle in which crop production is boosted, emissions lowered, and reliance on synthetic fertilizers reduced. Moreover, unlike CCS it is a cost-effective carbon sequestration method: under a basic scenario sequestering biochar from biofuels produced by pyrolysis would be competitive when carbon prices reach US\$37 (carbon currently fetches €21.55 on the European market, that is \$30.5, and prices are expected to increase strongly in the near future).

### **Examples of Real Life Applications**

Research level

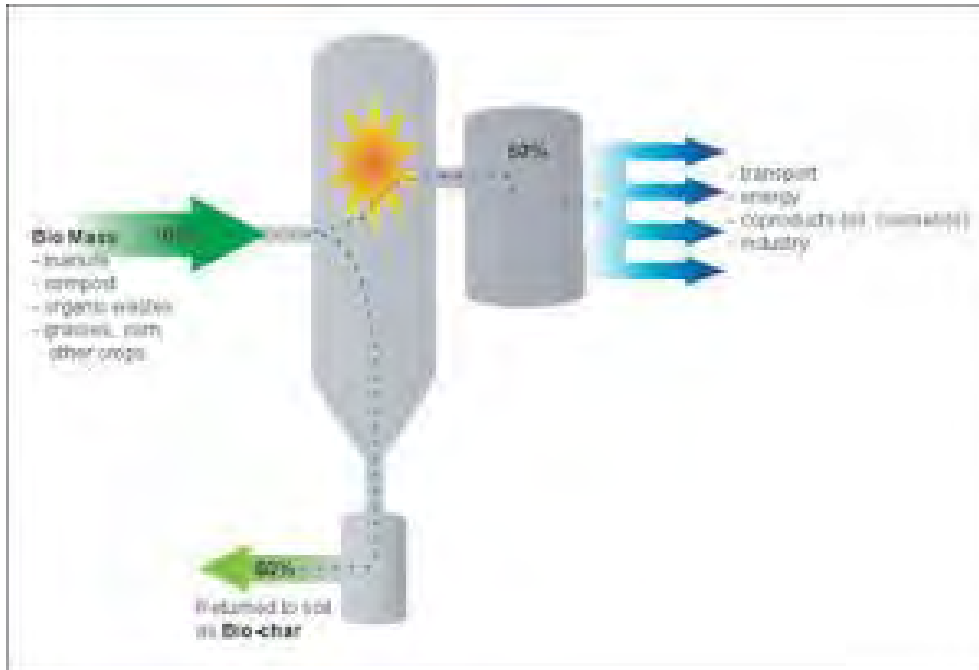

## COBY (Cotton By-products) Process<sup>239</sup> USA, Research

<b>Crop</b>	Cotton
<b>Residue</b>	Cotton gin, etc.
<b>Process</b>	COBY (Cotton Byproducts) process
<b>Equipment</b>	Commercially available pellet mills
<b>Main Product</b>	Pellets for food, fuel or fertilizers

### Detailed Process Description

The ARS scientists have devised a new low-cost way to add value to cotton waste, a patented system known as the COBY (Cotton Byproducts) process. It uses a hot, gelatinized starch solution that acts as a glue to hold the cotton waste ingredients together and a lubricant to smooth the mixture's flow through the extrusion equipment. The procedure cooks, sterilizes, and improves nutrient availability in the mixture, which can be formed into pellets for various uses.

### Parameters for Procurement Specifications

Insta-Pro International, a division of Triple "F," Inc., of Des Moines, Iowa, a manufacturer and marketer of extrusion equipment and technologies, supplied the Lubbock researchers with an extruder to begin the COBY testing. USDA has granted Insta-Pro an exclusive license to either process COBY or issue a sublicense to other companies. Insta-Pro's marketing strategy is to offer cotton gins the opportunity to purchase the system to process COBY products, along with granting the gins a sublicense agreement for the manufacture and marketing of COBY products

### Examples of Real Life Applications

Trial COBY Feeding Trial Texas Tech University in Lubbock  
Trial COBY Feeding Trial Stoneville Mississippi

### Suppliers

The research is part of Quality and Utilization of Agricultural Products (#306), an ARS National Program described on the World Wide Web at <http://www.nps.ars.usda.gov>.

---

<sup>239</sup><http://www.ars.usda.gov/IS/AR/archive/apr02/cotton0402.htm> cotton0402.htm



**Filter aide/Filter media/Filter powder  
USA, Research**

<b>Crop</b>	Sugarcane
<b>Residue</b>	Sugar mill boiler ash from bagasse
<b>Process</b>	Hydroseparation
<b>Equipment</b>	Hydro-separator
<b>Main Product</b>	Filtration materials and absorbent products

**Production Capacity:**<sup>240</sup>

The filtration materials of the present invention can be derived from any sugar mill boiler ash no matter where the location or the conditions employed for combustion of the bagasse fibre. The principal variation in the combustion product of bagasse fibre from sugar mill to sugar mill is the rate of feed of the bagasse fibre to the boiler. For example, where a sugar mill has a surplus of bagasse fibre which must be disposed of, there is sometimes a tendency to feed the boiler with bagasse at a much higher rate than provided for in the original boiler design. This results in an increase of partially or not well burnt fibres resulting from the combustion of the bagasse thereby providing sugar mill boiler ash of higher activated carbon content. As used herein reference to activated carbon content means the adsorptive properties of a particular product. In contrast to the foregoing example, in some cases where an efficient sugar mill does not have an excess of bagasse fibre available, and is endeavoring to minimize the use of any supplementary oil or coal fuel, considerable care is taken in the combustion control of the boiler. In these circumstances, the bagasse fibre is very well burnt, and the resulting ash has very low activated carbon content.

The present invention allows the production of filtration materials from any of the foregoing ashes (i.e. low or high activated carbon content), and depending on the required characteristics of the filtration material such as its flow rate index and adsorptive properties, one can, by selecting the particular raw material ash to be used and/or varying the processing procedures and controls as described later herein, produce (a) filtration products with a low activated carbon content (b) filtration products with high activated carbon content, and (c) a carbonaceous adsorbent material of very high activated carbon content which has uses other than as a filtration material.

The filtration materials with a low activated carbon content are generally those having a loss on ignition (at 900.sup.c) not exceeding about 12 percent by weight and the filtration materials with a relatively high activated carbon content are those having a loss of ignition in the range of about 12 to about 30 percent by weight. The loss on ignition is a measure of the combustible material in the product which for all intents and purposes is a measure of the carbon content.

---

<sup>240</sup> <http://freepatentsonline.com/4745096.html>

Detailed Process Description:<sup>241</sup>

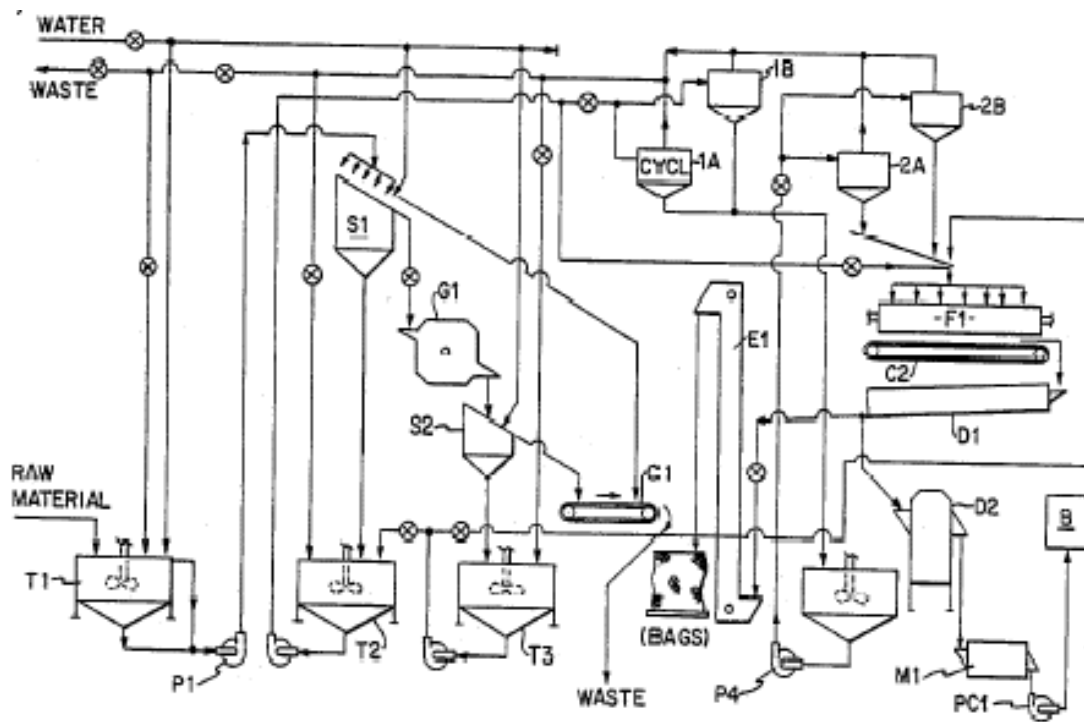

U.S. Patent May 17, 1988 Sheet 1 of 5 4,745,096

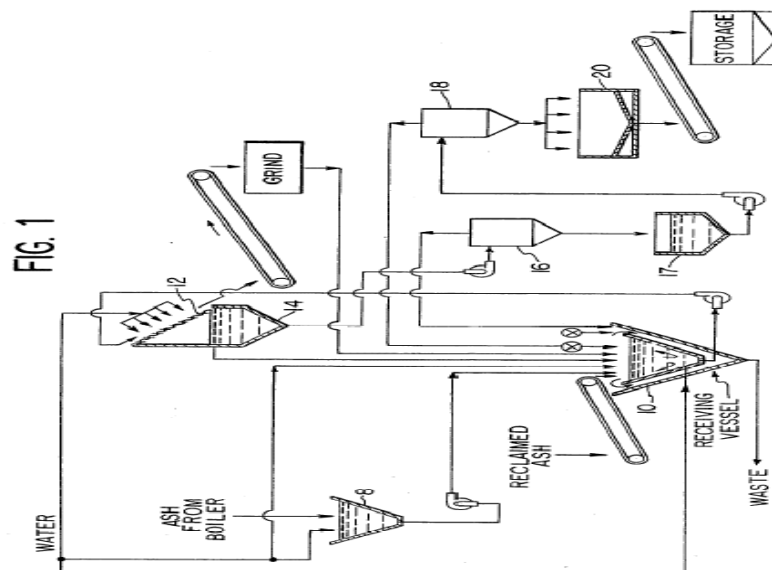

<sup>241</sup> <http://freepatentsonline.com/4745096.pdf>





In addition to functioning as a thickener, this receiving vessel can also act as a hydroseparator. When used as a hydroseparator water flows upwards in the vessel, counter-current to the ash particles which are settling towards the bottom of the vessel. The use of the thickener vessel is preferable but not essential to the process. Its purpose is to build up a suitable concentration or content of ash particulate matter in the slurry to ensure having adequate yield of the filtration material from the processing plant in order to make recovery and use of the filtration product economically feasible. Thus, the ash from the boiler or settling pond could be fed directly to the single or double deck screen described therein. However, the ash slurry from a sugar mill generally has a solid content of less than one percent which would lead to lower yields of filtration material without the use of the thickener step to increase the concentration of the solids to be processed into the filtration and activated carbon adsorbent materials of the present invention.

By controlling the upwards velocity of the water and the feed rate of the slurry of boiler ash to the hydroseparator it is possible to extract from the bottom of the hydroseparator that large proportion of the boiler ash which is made up of predominantly well burnt ash particles, with a comparatively low activated carbon content. This particulate material generally has a loss of ignition below about 12 percent by weight. The unburnt fibres, partially burnt or charred fibres and the small light carbon particles can be separated from the bulk of the ash particulate material and carried upwards with the flow of water over a weir and discharged either to waste or to a separate collecting vessel. This separation procedure enables one to control the activated carbon content of the filtration material of the present invention. The greater the upwards velocity of the water in the hydroseparator, the lower will be the proportion of particulate material of high carbon content in the recovered filtration product. A higher water velocity causes greater turbulence in the hydroseparator which results in a greater proportion of partially burnt or charred fibres being carried with the overflow from the hydroseparator. Conversely, a reduction in upwards water velocity reduces the proportion of the foregoing particulate material being carried with the overflow thereby resulting in a filtration product with a higher activated carbon content. As an example of a suitable water velocity it has been found that passing water through the hydroseparator at the rate of 32 liters per minute causes an upward flow of water at top of the hydroseparator of 50 mm per minute. At the foregoing velocity the underflow from the hydroseparator contains a filtration material which is of relatively low carbon content.

The ash slurry extracted from the bottom of the hydroseparator or thickener vessel is then pumped as a slurry to a vibrating screen 12 which may be either a single deck or double deck screen. The selection of either a single deck or double deck screen is dependent on the characteristics of properties desired for the filtration material and controls the activated carbon content and the particle size of the filtration product. Thus, when a single deck screen is used the screening means may comprise a screen cloth having the same size apertures. Such a screen cloth may have apertures anywhere from 375 microns or less (e.g. 300, 212, 180, 150, 75, etc.). For illustration purposes

and convenience only, reference is made in FIG. 1 to a vibrating screen having 300 micron size apertures. This screen causes a separation of those ash particles having a particle size below 300 microns from those particles having a particle size greater than 300 microns. The oversize material separated by the screen which did not pass through consists primarily of a small proportion of unburnt fibres, of the order of about 1 % to about 3% by weight of the total raw material fed to the vibrating screen and of the order of about 3% to about 10% by weight of charred fibres based on the weight of the total raw material feed. To ensure that particles smaller in size than 300 microns are not carried away with the particles of a size greater than about 300 microns, water sprays are directed onto the screen deck which results in the particulate material of less than about 300 micron size being washed through the screen apertures.

If desired, as previously indicated, a double deck screen may be used in place of the single deck screen. The purpose of the double deck screen is to permit the recovery of a larger particle size fraction from the boiler ash which has been found to contain a substantial quantity of activated carbon thus making it useful for commercial applications requiring a filtration product of high activated carbon or as an adsorbent product. This fraction is separated from the boiler ash by using a second screen preferably with 1700 microns size apertures. Obviously, if desired, this screen can be of smaller or larger micron size (e.g. 1900, 1800, 1500, 1300, 1000, etc.). For illustrative purposes herein, the second screen will be identified as one having 1700 micron size apertures. The ash particulate material ranging in size from about 300 to about 1700 microns is recovered on top of the lower deck 300 micron screen. The oversize ash particles, i.e. greater than about 1700 microns, are recovered on top of the 1700 micron size screen and processed in the same manner as the oversize material using only a single screen deck.

The boiler ash particles which are smaller than about 300 microns together with the process water and spray water are collected in a hopper 14 below the screen deck. If the amount of process water is excessive, any overflow from the screen hopper can be returned in a closed circuit to the hydroseparator for reuse.

The partially processed ash having a particle size of less than about 300 microns which makes up the underflow from the hydroseparator 10 is preferably extracted again in a slurry form from the screen hopper 14 and pumped at a solids content in the range of 5% to about 20% by weight, preferably about 10% by weight, to a first stage hydrocyclone station 16. The purpose of the hydrocyclone is to classify the ash particles and remove a substantial proportion of the very fine particles i.e. those smaller than about 12 to 15 microns. The selection of a suitable hydrocyclone to achieve the desired particle separation is within the skill of the art. A suitable hydrocyclone is a "Warman" Series R 3 inch cyclone. The overflow from the first stage hydrocyclone 16 which contains the fine particles having a size of less than about 12 to 15 microns can either flow to waste or to a further collection point and if desired can be combined with the hydroseparator overflow. The overflow can be added to the hydroseparator to build up the fine particles as a means for controlling the flow rate index.

The underflow from the first stage hydrocyclone, which is the bulk of the solids fed to the hydrocyclone, is collected in a tank 17 from which it is pumped in slurry form at a solids content in the range of about 5% to 20% by weight, preferably 10% by weight to a second stage hydrocyclone station 18. The ash solids in this slurry have a particle size in the range of about 12 to 15 to about 300 microns. The particle classification process carried out at first hydrocyclone station 16 is repeated again with the use of a second "Warman" Series R 3 inch cyclone station 18 so as to provide substantially complete removal of ash particles having a micron size smaller than about 12 to 15 microns. These fine particles are handled in the same manner as previously described in connection with the first stage hydrocyclone 16.

The use of a second hydrocyclone station 18 is not critical to the process but is preferred, particularly where the sugar mill boiler ash used to obtain the filtration materials of my invention are derived from a settling pond rather than being pumped directly from the sugar mill boiler. It has been found that sugar mill boiler ash reclaimed from a settling pond generally has a high proportion of particles of less than 12 to 15 microns which therefore makes it desirable to repeat the first stage hydrocyclone particle classification and separation in order to assure that the predominant portion of the fine particulate material is separated from the underflow in the hydrocyclone in order to obtain a suitable flow rate index. The choice of using one or both hydrocyclones in the process is also dependent on the flow rate index desired for the filtration produce. Thus, where a relatively low flow index is desired, i.e. less than about 1, a greater proportion of the fine particulate material may be retained in the filtration product thus making it unnecessary to process the product through two hydrocyclone stations. In contrast, where a high flow rate index is desired processing through two hydrocyclone stations is generally desirable. There are also some sugar mills where the boiler ash contains only a very small number of fine particles and in such case it is possible to eliminate the use of any hydrocyclones to produce a suitable filtration product.

The underflow from the second stage hydrocyclone station is in the form of a concentrated slurry of water and fully processed boiler ash particles. This underflow is then dewatered by conventional means such as by a rotary drum vacuum filter 20. Other conventional dewatering or drying devices may be used. The dewatered product, which is in the form of filter cake, is scraped from the vacuum filter and conveyed to a storage area. This product has a moisture content in the range of about 20% to about 30% by weight and is usable in this form as a filtration material for swimming pool filtration. Where a lower moisture content is required or desirable such as to either facilitate automatic packaging or by the product specification for some filtration processes other than swimming pools, the recovered filtration materials can be subjected to conventional drying means such as a fluid bed dryer for partial or total drying.

The overflow from the first and/or second stage hydrocyclones can be dewatered in the same manner as previously described to recover a product with only a very small quantity of ash particles greater than about 12 to 15 microns. These fine ash particles can be either discarded or used to modify

the flow rate index properties of the filtration product by adding a predetermined quantity of these fine particles to the filtration product composed of particles of which approximately 90% by weight are in the range of about 375 to about 12 to 15 microns.

The fraction of boiler ash particulate material separated out on a double deck screen having a particle size in the range of about 300 or 375 microns to about 1700 microns is principally composed of charred or partially burnt bagasse fibres having a high activated carbon content. This material can be used as an activated carbon product in the form in which it is screened from the boiler ash slurry or can be reduced in particle size by conventional grinding means such as for example wet grinding in a rod or ball mill followed by screening and drying to a fine activated carbon powder preferably having a particle size in the range of about 12 to 15 to about 300 to 375 microns. This fine activated carbon powder can be mixed or blended in a measured quantity with that ash fraction that consists essentially of the low activated carbon particles of the present invention to provide a filtration product requiring a relatively high carbon content which is necessary for filtration of certain liquids requiring adsorption of colors, odors, etc. Alternatively, the high activated carbon fraction described above can be combined with the low activated carbon fraction represented by the underflow from the hydroseparator and together passed through the first or second stage hydrocyclones.

As previously indicated, the proportion of activated carbon particles or fibres present in the mill ash discharged from the boiler of a sugar mill varies greatly from case to case, and depends upon such factors as the design and operating conditions of the boiler, the combustion control in the boiler and the moisture content of the bagasse fired to the boiler. Thus by sampling and testing boiler ash discharged from various sugar mill boilers, it is possible to select ash having particularly high levels of activated carbon particles. The high carbon content raw material can be used to produce a filtration product having a higher proportion of activated carbon or the activated carbon content can be separated out as heretofore described and made commercially available for applications requiring an activated carbon product. It has been found that in a few cases the proportion of activated carbon particles in the boiler ash is so high that the ash needs little or no further processing to be used as an activated carbon product. For example, boiler mill ash of very high proportion of activated carbon particles can be obtained by combining bagasse and the residue obtained in the manufacture of furfural.

The ash resulting from the combustion of this material usually results in a high carbon content material. The residue from the furfural extraction process is obtained by using bagasse in the furfural extraction process and returning the furfural residue from this process to the sugar mill boiler where it is combined with untreated bagasse for use as a fuel in the boiler to produce sugar mill boiler ash high in activated carbon content. Reference in this specification and the attached claims to bagasse ash is intended to include ash from the combustion of such furfural residue alone or in combination with untreated bagasse.

The recovery of the filtration produce described herein can also be achieved

by essentially dry process techniques. For example, the sugar mill boiler can be removed from the boiler or a settling pond, dried by conventional means and screened to separate out oversize particles such as those having a particle greater than about 1700 microns. If desired, the oversize material can be crushed to below 1700 micron size and combined with the initial particulate matter which passed through the 1700 micron size screen. The ash based product can be further fractionated by separating through screening those particles having a size in the range of about 375 to about 1700 microns which are high in activated carbon content from those ash particles of less than about 375 microns which are relatively low in activated carbon content. This low carbon content particulate material derived from sugar mill boiler ash is treated by dry process techniques such as an air classifier to remove a substantial majority of the particulate material having a particle size below about 12 to 15 microns.

**Job Potential:** Additional income for farmers

**Parameters for Procurement Specifications:**<sup>242</sup>

The filtration materials of the present invention can be derived from any sugar mill boiler ash no matter where the location or the conditions employed for combustion of the bagasse fibre

**Example of Real Life Applications**

**Level of Use:** Research Level

**Name of Project:** Bagasse Residue Filter Materials and Activated Carbon Products and Methods of Manufacturing the Same

**Location:** British Virgin Islands, USA

---

<sup>242</sup> <http://freepatentsonline.com/4745096.html>

## **Continuous Rotary Carbonizer Philippines, Research**

<b>Crop</b>	Coffee, Coconut, Rice
<b>Residue</b>	Hulls and Coir Dust
<b>Process</b>	Carbonization
<b>Equipment</b>	Screw feeder assembly, carbonizing kiln assembly and air distributor assembly.
<b>Main Product</b>	Charcoal fine
<b>By-Product</b>	Briquettes

### **Technical Description of Technology**

The Forest Products Research and Development Institute (FPRDI) carbonizer is made of various steel materials, like mild steel plates, bars and pipes. The equipment is composed of screw feeder assembly, carbonizing kiln assembly and air distributor assembly. The screw feeder assembly consists of a hopper with a feed screw assembly made of 13 mm. mild steel plate. The transport tube is horizontally interconnected at the center of the carbonizer assembly by a free wheeling flange. The carbonizing kiln assembly is made up of a carbonizing chamber made of 5.0 mm thick mild steel plate. It is an eight-sided conical cylinder positioned horizontally with the feeder inlet located at the center of the smaller end and the discharger at the larger diameter end.

### **Detailed Process Description**

Pre-ignition material is inserted to start up operation at the 76 mm diameter handhole located at the top. A chimney is also connected with a free wheeling flange at the discharge-end of the kiln. The air distribution assembly is located at the bottom of the kiln assembly. Air is distributed inside the kiln in three separate chamber with perforated holes at the bottom of the kiln. Air distribution is regulated at each chamber by individual ball valve. The carbonizer converts agro-forestry waste like coffee hulls and sawdusts into fine charcoal fines that are processed into briquettes.

### **Main Products**

Briquettes

### **Environmental Considerations**

The briquetting machine is a simple energy- and money-saving device used in converting charcoal fines and charcoal from sawdust, rice hull, coconut coir dust and other carbonaceous fine materials into charcoal briquettes for

industrial uses. It consists of molds, plungers, top sliding platen, common lever, fulcrum, steel plates where the molds are welded, and casing assembly.

### **Investment and Operating Cost**

The FPRDI-developed carbonizer, adjudged second prize winner in the mechanical inventions category in 1984, is a simple, low-cost machine capable of carbonizing sawdust, rice hull, coconut coir dust and other carbonaceous fine materials. It has a rectangular trough, hopper, charcoal receiver, swing-type metal plate cover and fire box.

Cost of Equipment : P 268,000 (1997)

Capacity : 152 kg/hr.

IRR : 52%

NPV : P 380,900

BCR : 1.24

Payback period : 2 years

### **Examples of Real Life Applications**

Forest Products Research and Development Institute  
Department of Science and Technology

### **Sources:**

1. <http://setup.dost.gov.ph/commerce.php?view=212>
2. <http://community.uplb.edu.ph/fprdi/publications/techflow/tf2briquettor.htm>

## Ethanol Production from Simultaneous Saccharification and Fermentation (SSF) Sweden, Research

<b>Crop</b>	Rice
<b>Residue</b>	Rice Straw
<b>Process</b>	Biochemical Conversion
<b>Equipment</b>	
<b>Main Product</b>	Ethanol
<b>By-Product</b>	Glycerol

### Technical Description of Technology

Ethanol production from rice straw by simultaneous saccharification and fermentation (SSF) with *Mucor indicus*, *Rhizopus oryzae*, and *Saccharomyces cerevisiae* was investigated and compared with pure cellulose,

The straw was pretreated with dilute-acid hydrolysis. The SSF experiments were carried out aerobically and anaerobically at 38 °C, 50 g/l dry matter (DM) solid substrate concentration and 15 or 30 filter paper unit (FPU)/g DM of a commercial cellulase. The experiments were ended after 7 days, while an average of 2–3 days were usually enough to achieve the maximum ethanol yield. All the strains were able to produce ethanol from the pretreated rice straw with an overall yield of 40–74% of the maximum theoretical SSF yield, based on the glucan available in the solid substrate. *R. oryzae* had the best ethanol yield as 74% from rice straw followed by *M. indicus* with an overall yield of 68% with 15 FPU/g DM of cellulase. Glycerol was the main byproduct of the SSF by *M. indicus* and *S. cerevisiae* with yields 117 and 90 mg/g of equivalent glucose in the pretreated straw, respectively, while *R. oryzae* produced lactic acid as the major byproduct with yield 60 mg/g glucose equivalent in pretreated rice straw under anaerobic conditions. The cellulose fraction of lignocelluloses can be converted to ethanol by either simultaneous saccharification or fermentation (SSF) or separate enzymatic hydrolysis and fermentation (SHF) processes. SSF is more favored because of its low potential costs. It results in higher yield of ethanol compared to SHF by minimizing product inhibition.

*M. indicus*CCUG22424 and *R. oryzae*CCUG28958, obtained from Culture Collection, University of Göteborg (Göteborg, Sweden) were used in the experiments. These fungi were maintained on agar slants containing (g/l): d-glucose, 40; soy peptone, 10; agar, 20 at pH 5.5 and 30±1 °C. Spore suspension was prepared by addition of 10 ml 0.05M buffer citrate to slant and shaking it vigorously with tube shaker. One milliliter of the suspension, which contained 5(±1)×10<sup>6</sup> spores/ml of *M. indicus* or *R. oryzae* was added to each flask. The strain of *S. cerevisiae* used was *Thermosacc*, stress-tolerant



yeast for high alcohol, and high-temperature fermentations (Alltech Denmark A/S). It was grown at  $30\pm 0.5$  °C and maintained at 4 °C on agar slants containing (g/l):

Glucose, 20; yeast extract, 3; malt extract, 3; agar, 20.

### **Detailed Process Description**

Simultaneous saccharification and fermentation (SSF) of rice straw was examined and compared with pure cellulose, Avicel, as a reference. The experiments were carried out under aerobic and anaerobic conditions, where the cellulase enzymes produced glucose from the cellulose and *S. cerevisiae* simultaneously assimilated the glucose to ethanol.

SSF was performed either under aerobic or anaerobic condition. A media contains (g/l): yeast extract, 5; (NH<sub>4</sub>)<sub>2</sub>SO<sub>4</sub>, 7.5; K<sub>2</sub>HPO<sub>4</sub>, 3.5; MgSO<sub>4</sub>·7H<sub>2</sub>O, 0.75; CaCl<sub>2</sub>·2H<sub>2</sub>O, 1; pretreated rice straw or pure cellulose (Avicel), 50 and 0.05M buffer citrate were used in 250 ml Erlenmeyer flasks. Medium pH was adjusted to  $5.5\pm 0.1$  for the filamentous fungi and  $5\pm 0.1$  for *S. cerevisiae* by NaOH (2 M). It was then autoclaved and the centrifuged microorganisms, the required enzyme, and 0.1 g Tween 80 (1 g/l) were added to each flask aseptically. The final volume in each flask was 100 ml. All the SSF experiments were performed at 38 °C. The enzyme loading was 15 or 30 FPU/g DM, which corresponds to 25 and 50 FPU/g cellulose of the rice straw.

In aerobic conditions, the flasks were covered with cotton, whereas they were equipped with a setup in anaerobic conditions. This setup involved a loop-trap containing glycerol to allow the gas outlet and preventing entrance of air, and two needles for sample removal and sparging nitrogen gas to the flasks, as described earlier. Pure nitrogen gas was sparged into the media at the beginning of the fermentation and during the sampling. After 7 days SSF, the cultures were examined for contamination by microscope.

All the experiments were performed in duplicate and the average standard deviation of the duplicated experiments were less than 3.8 for glucose, 5.3 for glycerol, 5.2 for ethanol, 6.7 for cellobiose, 8.4 for citric acid, and 4.9% for lactic acid concentration.

### **Main Products**

Ethanol

### **Environmental Considerations**

It may be concluded that ethanol can be produced by SSF from pretreated rice straw. *M. indicus* and *R. oryzae* are good alternatives to the baker's yeast for this purpose. These fungi are able to produce ethanol by a higher overall yield than by *S. cerevisiae* in a similar period of time.

Another advantage of the used strains of filamentous fungi is the valuable products that could be produced from their biomass, e.g. a superabsorbent material or glucosamine. On the other hand, *R. oryzae* has a drawback in

comparison with the two other strains. It produced lactic acid as a byproduct, but it was at the expense of lower glycerol, and not ethanol yield. *R. oryzae* is a cellobiose-utilizing organism, which can facilitate saccharification of cellulose.

### **Examples of Real Life Applications**

Chemical Engineering Department, Isfahan University of Technology, Isfahan, Iran

Chemical Reaction Engineering, Chalmers University of Technology, Göteborg, Sweden

Department of Biology, Isfahan University, Isfahan, Iran

School of Engineering, University College of Borås, SE-50190 Borås, Sweden

### **Sources:**

<http://www.aseanbiotechnology.info/Abstract/21020579.pdf>

## **About the UNEP Division of Technology, Industry and Economics**

The UNEP Division of Technology, Industry and Economics (DTIE) helps governments, local authorities and decision-makers in business and industry to develop and implement policies and practices focusing on sustainable development.

The Division works to promote:

- > sustainable consumption and production,
- > the efficient use of renewable energy,
- > adequate management of chemicals,
- > the integration of environmental costs in development policies.

### **The Office of the Director, located in Paris, coordinates activities through:**

- > **The International Environmental Technology Centre** - IETC (Osaka, Shiga), which implements integrated waste, water and disaster management programmes, focusing in particular on Asia.
- > **Production and Consumption** (Paris), which promotes sustainable consumption and production patterns as a contribution to human development through global markets.
- > **Chemicals** (Geneva), which catalyzes global actions to bring about the sound management of chemicals and the improvement of chemical safety worldwide.
- > **Energy** (Paris), which fosters energy and transport policies for sustainable development and encourages investment in renewable energy and energy efficiency.
- > **OzonAction** (Paris), which supports the phase-out of ozone depleting substances in developing countries and countries with economies in transition to ensure implementation of the Montreal Protocol.
- > **Economics and Trade** (Geneva), which helps countries to integrate environmental considerations into economic and trade policies, and works with the finance sector to incorporate sustainable development policies.

*UNEP DTIE activities focus on raising awareness,  
improving the transfer of knowledge and information,  
fostering technological cooperation and partnerships, and  
implementing international conventions and agreements.*

For more information,  
see **[www.unep.fr](http://www.unep.fr)**

**UNEP DTIE  
International Environmental  
Technology Centre (IETC)**

Osaka Office  
2-110 Ryokuchi Koen, Tsurumi-ku  
Osaka 538-0036, Japan  
Tel: +81 6 6915 4581  
Fax: +81 6 6915 0304

Shiga Office  
1091 Oroshimo-cho, Kusatsu City  
Shiga 525-0001, Japan  
Tel: +81 77 568 4581  
Fax: +81 77 568 4587

E-mail: [ietc@unep.or.jp](mailto:ietc@unep.or.jp)  
URL IETC: <http://www.unep.or.jp/>

[www.unep.org](http://www.unep.org)

United Nations Environment Programme  
P.O. Box 30552 Nairobi, Kenya  
Tel: ++254-(0)20-762 1234  
Fax: ++254-(0)20-762 3927  
E-mail: [unep@unep.org](mailto:unep@unep.org)



*Globally, 140 billion metric tons of biomass wastes are generated every year from agriculture equivalent to about 50 billion tons of oil. This energy can displace fossil fuel, reduce emissions of greenhouse gases and provide renewable energy to some 1.6 billion people in developing countries, which still lack access to electricity. As raw materials, biomass wastes have attractive potentials for large-scale industries and community-level enterprises. For efficient and effective conversion, appropriate selection of technologies is one of the vital pre-conditions. This compendium is compiled to assist in selection process for the technologies. This is a compilation of information about the technologies for converting waste agricultural biomass into material or energy resource. The technologies listed range from highly sophisticated equipment from industrialized countries to simple technologies from the developing countries. Different levels of use are also considered, i.e., commercial use, demonstration projects, and research level technologies. The technologies for different type of waste agricultural biomass and size of output are also considered. Technologies listed in the Compendium are limited to those that use cellulosic agricultural waste biomass.*