



CLEAN DEVELOPMENT MECHANISM

CDM METHODOLOGY BOOKLET

Sixth edition
Information updated as of EB 79
November 2014



United Nations
Framework Convention on
Climate Change



TABLE OF CONTENTS

TABLE OF CONTENTS

Acknowledgement	2
Foreword	3
Introduction	4
1.1. Methodologies and the Booklet	5
1.2. Categorization by mitigation activity type (methodology categorization table)	7
1.3. Categorization by applied technology type/measure (methodology family trees)	13
1.4. Programmes of activities	22
1.5. Standardized baselines	23
1.6. Methodologies addressing suppressed demand	24
1.7. Methodologies having benefits for women and children	25
1.8. Introduction to methodology Summary sheets	26
Icons, abbreviations and glossary	29
2.1. Icons used in this booklet	30
2.2. Abbreviations used in this booklet	34
2.3. Glossary	35
Methodologies for CDM Project activities	39
3.1. Introduction to Methodologies for CDM project activities	40
3.2. Methodological tools for CDM project activities	41
3.3. Methodologies for large-scale CDM project activities	44
3.4. Methodologies for small-scale CDM project activities	157
Methodologies for afforestation and reforestation (A/R) CDM project Activities	250
4.1. Introduction to methodologies for A/R CDM project activities	251
4.2. Methodological tools for A/R CDM project activities	252
4.3. Methodologies for large-scale A/R CDM project activities	254
4.4. Methodologies for small-scale A/R CDM project activities	257

ACKNOWLEDGEMENT

© 2014 United Nations Framework Convention on Climate Change

First edition: November 2010

Second edition: November 2011

Third edition: May 2012

Fourth edition: November 2012

Fifth edition: November 2013

Sixth and current edition: November 2014

Available online: <<https://cdm.unfccc.int/methodologies/>>

The production of this booklet benefited from the suggestions of Secretariat staff and thoughtful comments from several experts on the content that would be most helpful to people wishing to find and understand methodologies and methodological tools of interest to them. In order to enhance its utility and respond to the needs of stakeholders the Secretariat welcomes comments and suggestions, which can be emailed to: CDM-info@unfccc.int.

This booklet will also be updated regularly in order to reflect changes in approved methodologies and methodological tools. The latest version of the booklet is available on the UNFCCC website. It is also possible to contact the Secretariat and request CDs of the booklet.

For further information contact:

United Nations Climate Change Secretariat

UN Campus

Platz der Vereinten Nationen 1

53113 Bonn, Germany

Telephone +49. 228. 815 10 00

Telefax +49. 228. 815 19 99

secretariat@unfccc.int

www.unfccc.int

Photos:

Cover	Oetomo Wiropranoto CDM project 0673: Darajat Unit III Geothermal Project
Page 4	Pedro Guinle CDM project 1843: Primavera Small Hydroelectric Project
Page 29	MSKVN Rao CDM project 0505: Methane recovery and power generation in a distillery plant
Page 39	Jie He CDM project 1135: Jiangxi Fengcheng Mining Administration CMM Utilization Project
Page 44	Ling Gao CDM project 1135: Jiangxi Fengcheng Mining Administration CMM Utilization Project
Page 157	Tao Ketu CDM project 2307: Federal Intertrade Pengyang Solar Cooker Project
Page 250	Pedro Guinle CDM project 0968: Incomex Hydroelectric Project
Page 254	Vietnam DNA CDM project 2363: Cao Phong Reforestation Project
Page 257	Anabele Natividad CDM project 0931: San Carlos Renewable Energy Project

Art direction and design: Heller & C GmbH, Cologne

ISBN 978-92-9219-084-2

FOREWORD



Environmental integrity is at the heart of the CDM and methodologies have a major role in ensuring this integrity. Methodologies are required to establish a project's emissions baseline, or expected emissions without the project, and to monitor the actual ongoing emissions once a project is implemented. The difference between the baseline and actual emissions determines what a project is eligible to earn in the form of credits. Methodologies are essential when quantifying emission reductions in an uncapped environment on a project-by-project basis.

The function of methodologies is easy to grasp, but the methodologies themselves can be quite complex. They are necessarily diverse in their composition and application in order to accommodate the wide range of activities and locales covered by the CDM. Hence this publication, designed to guide users through the complex world of CDM methodologies.

By clearly summarizing, classifying and illustrating the methodologies available under the CDM, and then enhancing the means by which to search those methodologies, this publication serves to guide potential CDM project participants.

It is my fervent hope, and that of the team that developed this work, that it will contribute to a rise in the number of CDM projects, increase the use of methodologies that directly benefit women and children, and enhance the regional distribution of projects, which is a key desire of Parties to the Kyoto Protocol, the CDM Executive Board and this secretariat.

A handwritten signature in blue ink, which appears to be 'C. Figueres'. The signature is stylized and fluid, written in a cursive-like style.

Christiana Figueres, *Executive Secretary*

United Nations Framework Convention on Climate Change



CDM Methodology Booklet

Chapter I

INTRODUCTION

1.1. METHODOLOGIES AND THE BOOKLET

BASELINE AND MONITORING METHODOLOGIES

The Clean Development Mechanism (CDM) requires the application of a baseline and monitoring methodology in order to determine the amount of Certified Emission Reductions (CERs) generated by a mitigation CDM project activity in a host country. Methodologies are classified into five categories:

- Methodologies for large-scale CDM project activities;
- Methodologies for small-scale CDM project activities;
- Methodologies for large-scale afforestation and reforestation (A/R) CDM project activities;
- Methodologies for small-scale A/R CDM project activities;
- Methodologies for carbon capture and storage (CCS) project activities.¹

Methodologies often refer to methodological tools, which address specific aspects of the project activity, e.g. to calculate Greenhouse Gas (GHG) emissions from specific sources.

PURPOSE OF THE BOOKLET

This booklet provides concise summaries of CDM methodologies and description of methodological tools, approved by the CDM Executive Board (Board). It is arranged to assist CDM project developers in identifying methodologies that are suitable for their CDM project activities.² The general purpose of the booklet is to help in achieving the objective of the Board to raise awareness of CDM methodologies.

USE OF THE BOOKLET

The booklet is intended for use by varied audiences interested in the CDM and in particular potential CDM project developers who already have an idea of the mitigation project activities they intend to implement. It facilitates the initial selection of potentially applicable methodologies. However, it cannot provide detailed guidance on specific elements of each methodology nor replace the approved methodologies. Therefore, the project developers should refer to the original methodologies available on the [UNFCCC website](#).

This edition of the Booklet reflects the effective status of methodologies and methodological tools as of November 2014 (up to EB79). However, as methodologies and methodological tools may change, users of the booklet are encouraged to consult EB meeting reports subsequent to EB 79 to find out whether any changes have occurred.

CONTENT OF THE BOOKLET

Each methodology is presented through a one-page summary sheet, which provides the following information:

- Typical project(s) to which the methodology is applicable;
- Type(s) of GHG emission mitigation action;
- Important conditions for application of the methodology;
- Key parameters that need to be determined or monitored;
- Visual description of baseline and project scenarios.

A short textual description of each methodological tool is also contained in the booklet.

HOW TO FIND A SUITABLE METHODOLOGY

1. CATEGORIZATION BY MITIGATION ACTIVITY TYPE

This way of looking up methodologies is according to the relevant sectoral scopes and type of mitigation activities such as renewable energy, low carbon electricity generation, energy efficiency measures, fuel and feedstock switch, GHG destruction, GHG emission avoidance, displacement of a more-GHG-intensive output and GHG removal by sinks. Project developers knowing the type of mitigation activity to be implemented in their project activities can thus easily identify potentially suitable methodologies.

2. CATEGORIZATION BY APPLIED TECHNOLOGY TYPE/MEASURE

This second way of looking up methodologies focuses on the technology applied in the project activity. The categorization by technology type enables project developers to identify a set of comparable methodologies applicable to the technology that is going to be implemented in their project activities.

¹ There are no approved methodologies for CCS project activities

² For the purpose of this booklet, CDM project activities also refer to CDM programme of activities.

AFTER FINDING POTENTIALLY SUITABLE METHODOLOGIES

After identifying potentially applicable methodologies through the summary sheet, users should access the full text of the methodologies available on the [UNFCCC website](#). It is also advisable to look at information about existing CDM project activities that have already applied the methodologies, which is also available through this website.

If there is no approved methodology applicable, then one can propose a new methodology or request a revision of an approved methodology or methodological tool. In general, the new methodology option should be pursued if a project activity requires methodological approaches substantially different from an approved methodology. The revision option is suitable if an approved methodology is not applicable to a project activity, but the project activity is broadly similar to the one to which the approved methodology is applicable. For cases where an approved methodology is applicable to a project activity but minor changes in the methodology application are required due to the project-specific circumstances, requesting a deviation of an approved methodology could be considered.

If an approved methodology is unclear or ambiguous in its methodological procedures, a request for clarification may be submitted.

CDM PROJECT CYCLE

Once project participants have selected an applicable approved methodology, they apply it to their project activity and prepare a Project Design Document (PDD); this is the first step in the CDM project cycle. The methodology provides provisions for the core elements of a PDD:

- the demonstration of additionality;
- the establishment of the baseline scenario and the estimation of emission reductions or net removals; and
- the monitoring plan.

The main steps of the CDM project cycle and their actors are the following:

- Project design (Project Participants);
- National approval (Designated National Authority);
- Validation (Designated Operational Entity);
- Registration (CDM Executive Board);
- Monitoring (Project Participant);
- Verification (Designated Operational Entity);
- Issuance (CDM Executive Board).

USEFUL LINKS

UNFCCC CDM website

[<https://cdm.unfccc.int/>](https://cdm.unfccc.int/)

CDM methodologies, submission of proposed new methodologies and requests for clarification and revision

[<https://cdm.unfccc.int/methodologies/index.html>](https://cdm.unfccc.int/methodologies/index.html)

CDM project cycle

[<http://cdm.unfccc.int/Projects/diagram.html>](http://cdm.unfccc.int/Projects/diagram.html)

CDM project activities

[<https://cdm.unfccc.int/Projects/index.html>](https://cdm.unfccc.int/Projects/index.html)

CDM programmes of activities (PoA)

[<https://cdm.unfccc.int/ProgrammeOfActivities/index.html>](https://cdm.unfccc.int/ProgrammeOfActivities/index.html)

CDM sectoral scopes

[<https://cdm.unfccc.int/DOE/scopes.html>](https://cdm.unfccc.int/DOE/scopes.html)

CDM standardized Baselines

[<http://cdm.unfccc.int/methodologies/standard_base/index.html>](http://cdm.unfccc.int/methodologies/standard_base/index.html)

UNEP Risø CDM pipeline analysis and database

[<http://cdmpipeline.org/>](http://cdmpipeline.org/)

Finding applicable methodologies — two categorization approaches

There are two ways the booklet categorizes methodologies. The first approach – the methodology categorization table – is based on the sectoral scopes defined by the UNFCCC (see <<https://cdm.unfccc.int/DOE/scopes.html>>). This table allocates the methodology to generic mitigation activity types. This approach is useful for project developers who have not yet made a technology choice or CDM stakeholders who are interested in a type of mitigation activity.

It structures methodologies according to technology and the history of methodology development that has led to several “families” of methodologies all relating to a specific technology. It is appropriate for project developers who have already decided on a particular technology for their project.

1.2. CATEGORIZATION BY MITIGATION ACTIVITY TYPE (METHODOLOGY CATEGORIZATION TABLE)

In addition to the methodology sectoral scopes³, methodologies in this table are also categorized by the type of mitigation activity, these being renewable energy, low carbon electricity generation, energy efficiency measures, fuel switch, GHG destruction, GHG emission avoidance and GHG removal by sinks.

Sectoral scopes 1 to 3 (energy sectors – generation, supply and consumption) are first distinguished according to:

- Electricity generation and supply;
- Energy for industries;
- Energy (fuel) for transport;
- Energy for households and buildings.

And then categorized in terms of type of mitigation activity:

- Displacement of a more-GHG-intensive output:
 - i. Renewable energy;
 - ii. Low carbon electricity.
- Energy efficiency;
- Fuel and feedstock switch.

Sectoral scopes 4 to 15 (other sectors) are categorized according to these mitigation activities:

- Displacement of a more-GHG-intensive output;
- Renewable energy;
- Energy efficiency;

- GHG destruction;
- GHG emission avoidance;
- Fuel switch;
- GHG removal by sinks.

DESCRIPTION OF TYPES OF MITIGATION ACTIVITIES

DISPLACEMENT OF A MORE-GHG-INTENSIVE OUTPUT

This category refers to project activities where the consumption of a more-GHG-intensive output is displaced with the output of the project. The category is separately defined because of the importance of not just implementing the project activity, but also ensuring that the more-GHG-intensive output is displaced by the output of the project activity.

All renewable energy generation and low carbon energy generation project activities are part of this category. Many other methodologies are also allocated to this category depending upon how the emission reductions are calculated in the corresponding methodologies.

Examples:

- Power generation from waste energy recovery and supply to a recipient who was receiving more-GHG-intensive power;
- Power generation using renewable or low carbon energy sources and export of power to a grid with combined margin emission factor of more than zero and/or to a recipient using fossil fuel based power in the absence of project activity.

³ The Methodology categorization table allocates the methodology to the sectoral scope(s) that have been formally defined for it, which are primarily used as the basis of DOE accreditation. However, if there are additional sectoral scopes that are also applicable to the methodology, then the methodology is also shown in these sectors in the table. This is to make it potentially easier to look up the methodology.

RENEWABLE ENERGY

This category includes the use of various renewable energy sources.

Examples:

- Hydro power plant;
- Wind power plant;
- Solar cooker;
- Biomass-fired boiler.

LOW CARBON ELECTRICITY

This encompasses mainly greenfield electricity generation based on less carbon intensive fuel such as natural gas. As no power plant exists at the project location before implementation of the project, the mitigation activity is not fuel switch. At the same time the applied technology might not be best available technology, differentiating it from energy efficiency measures. A typical low carbon electricity project is the construction of a greenfield natural-gas-fired power plant. Also projects that reduce emissions due to grid extension or connection are included under this category where applicable.

ENERGY EFFICIENCY

The category energy efficiency includes all measures aiming to enhance the energy efficiency of a certain system. Due to the project activity, a specific output or service requires less energy consumption. Waste energy recovery is also included in this category.

Examples:

- Conversion of a single cycle to a combined cycle gas-fired power plant;
- Installation of a more efficient steam turbine;
- Use of highly efficient refrigerators or compact fluorescent lamps;
- Recovery of waste heat from flue gases;
- Recovery and use of waste gas in a production process.

FUEL OR FEEDSTOCK SWITCH

In general, fuel switch measures in this category will replace carbon-intensive fossil fuel with a less-carbon-intensive fossil fuel, whereas a switch from fossil fuel to renewable biomass is categorized as “renewable energy”. In case of a feedstock switch, no differentiation between fossil and renewable sources is applied.

Examples:

- Switch from coal to natural gas;
- Feedstock switch from fossil sources of CO₂ to renewable sources of CO₂;
- Use of different raw material to avoid GHG emissions;
- Use of a different refrigerant to avoid GHG emissions;
- Blending of cement in order to reduce demand for energy intensive clinker production.

GHG DESTRUCTION

The category GHG destruction covers activities that aim at the destruction of GHG. In many cases, the project includes capture or recovery of the GHG. The destruction is achieved by combustion or catalytic conversion of GHGs.

Examples:

- Combustion of methane (e.g. biogas or landfill gas);
- Catalytic N₂O destruction.

GHG EMISSION AVOIDANCE

This category includes various activities where the release of GHG emissions to the atmosphere is reduced or avoided.

Examples:

- Avoidance of anaerobic decay of biomass;
- Reduction of fertiliser use.

GHG REMOVAL BY SINKS

All A/R activities are allocated to this category. Through photosynthesis in plants, CO₂ from the atmosphere is removed and stored in form of biomass.

- Methodologies for large-scale CDM project activities
- Methodologies for small-scale CDM project activities
- Methodologies for small and large-scale afforestation and reforestation (A/R) CDM project activities
- AM0000** Methodologies that have a particular potential to directly improve the lives of women and children

Table VI-1. Methodology Categorization in the Energy Sector

Sectoral scope	Type	Electricity generation and supply	Energy for industries	Energy (fuel) for transport	Energy for households and buildings		
1 Energy industries (renewable-/ non renewable sources) Displacement of a more-GHG-intensive output	Renewable energy	AM0007	AM0007	AM0089	AM0053		
		AM0019	AM0036	ACM0017	AM0069		
		AM0026	AM0053		AM0072		
		AM0042	AM0069		AM0075		
		AM0052	AM0075		AM0094		
		AM0100	AM0089		ACM0022		
		AM0103	ACM0006		ACM0024		
		ACM0002	ACM0020		AMS-I.A.		
		ACM0006	ACM0022		AMS-I.B.		
		ACM0018	ACM0024		AMS-I.C.		
		ACM0020	AMS-I.C.		AMS-I.E.		
		ACM0022	AMS-I.F.		AMS-I.F.		
		AMS-I.A.	AMS-I.G.		AMS-I.G.		
		AMS-I.C.	AMS-I.H.		AMS-I.H.		
		AMS-I.D.			AMS-I.I.		
		AMS-I.F.			AMS-I.J.		
		AMS-I.G.			AMS-I.K.		
		AMS-I.H.			AMS-I.L.		
		Low carbon electricity		AM0029	AM0087		
				AM0045	AM0099		
	AM0074						
	AM0087						
	AM0099						
	AM0104						
	Energy efficiency		AM0014	AM0014		AM0058	
			AM0048	AM0048		AM0048	
			AM0049	AM0049		AM0084	
			AM0061	AM0055		AM0107	
			AM0062	AM0056			
			AM0076	AM0076			
			AM0084	AM0084			
			AM0102	AM0095			
			AM0107	AM0098			
			ACM0006	AM0102			
			ACM0007	AM0107			
			ACM0012	ACM0006			
ACM0013			ACM0012				
ACM0018			ACM0018				
AMS-II.B.	ACM0023						
AMS-II.H.							
AMS-III.AL.							

Table VI-1. Methodology Categorization in the Energy Sector (continued)

Sectoral scope	Type	Electricity generation and supply	Energy for industries	Energy (fuel) for transport	Energy for households and buildings	
1 Energy industries (renewable-/ non renewable sources) (continued)	Fuel/feedstock switch	AM0049	AM0049		AM0081	
		ACM0006	AM0056			
		ACM0011	AM0069			
		ACM0018	AM0081			
		AMS-III.AG.	ACM0006			
		AMS-III.AH.	ACM0009			
		AMS-III.AM.	ACM0018			
		AMS-III.AM.				
2 Energy distribution	Renewable energy	AMS-III.AW.	AM0069		AMS-III.AW.	
		AMS-III.BB.	AM0075			
	Energy efficiency	AM0067				
		AM0097				
		AMS-II.A.				
		AMS-III.BB.				
	Fuel/feedstock switch	AMS-III.BB.	AM0077			
3 Energy demand	Renewable energy				AMS-III.AE. AMS-III.AR.	
	Energy efficiency	AMS-III.AL.	AM0017			AM0020
			AM0018			AM0044
			AM0020			AM0046
			AM0044			AM0060
			AM0060			AM0086
			AM0068			AM0091
			AM0088			AM0113
			AM0105			AMS-II.C.
			AMS-I.I.			AMS-II.E.
			AMS-II.C.			AMS-II.F.
			AMS-II.F.			AMS-II.G.
			AMS-II.G.			AMS-II.J.
			AMS-II.L.			AMS-II.K.
			AMS-II.N.			AMS-II.L.
			AMS-II.P.			AMS-II.N.
						AMS-II.M.
						AMS-II.O.
						AMS-II.Q.
			AMS-II.R.			
			AMS-III.AE.			
			AMS-III.AR.			
			AMS-III.AV.			
			AMS-III.X.			
Fuel/feedstock switch	AMS-III.B.	ACM0003			AMS-II.F.	
		ACM0005			AMS-III.B.	
		AMS-II.F.				
		AMS-III.B.				

Table VI-2. Methodology Categorization other Sectors

Sectoral scope	Renewable energy	Energy Efficiency	GHG destruction	GHG emission avoidance	Fuel/Feedstock Switch	GHG removal by sinks	Displacement of a more-GHG-intensive output
4 Manufacturing industries	AM0007	AM0014	AM0078	ACM0005	AM0014		AM0070
	AM0036	AM0049	AM0096	ACM0021	AM0049		AM0095
	ACM0003	AM0055	AM0111	AM0057	AM0092		AM0114
	AMS-III.Z.	AM0070	AMS-III.K.	AM0065	ACM0003		ACM0012
	AMS-III.AS.	AM0106		AM0092	ACM0005		
	AMS-III.BG.	AM0109		AMS-III.L.	ACM0009		
		AM0114			ACM0015		
		ACM0012			AMS-III.N.		
		AMS-II.D.			AMS-III.Z.		
		AMS-II.H.			AMS-III.AD.		
		AMS-II.I.			AMS-III.AM.		
		AMS-III.P.			AMS-III.AS.		
		AMS-III.Q.					
		AMS-III.V.					
		AMS-III.Z.					
		AMS-III.AS.					
	AMS-III.BD.						
	AMS-III.BG.						
5 Chemical industries	ACM0017	AM0055	ACM0019	AM0053	AM0027		AM0053
	AM0053	AM0114	AM0021	AMS-III.M.	AM0037		AM0055
	AM0075	AMS-III.AC.	AM0028	AMS-III.AI.	AM0050		AM0069
	AM0089	AMS-III.AJ.	AM0098		AM0063		AM0081
					AM0069		AM0098
					AMS-III.J.		AM0114
				AMS-III.O.			
6 Construction					AMS-III.BH.		AMS-III.BH.
7 Transport	AMS-III.T.	AM0031			AMS-III.S.		
	AMS-III.AK.	AM0090			AMS-III.AY.		
	AMS-III.AQ.	AM0101					
		AM0110					
		ACM0016					
		AMS-III.C.					
		AMS-III.S.					
		AMS-III.U.					
		AMS-III.AA.					
		AMS-III.AP.					
		AMS-III.AT.					
		AMS-III.BC.					
8 Mining/mineral production	ACM0003		ACM0008		ACM0005		
			AM0064		ACM0015		
			AMS-III.W.				
9 Metal production	AM0082	AM0038		AM0030	AM0082		
		AM0059		AM0059			
		AM0066		AM0065			
		AM0068					
		AM0109					
		AMS-III.V.					

Table VI-2. Methodology Categorization other Sectors (continued)

Sectoral scope	Renewable energy	Energy Efficiency	GHG destruction	GHG emission avoidance	Fuel/Feedstock Switch	GHG removal by sinks	Displacement of a more-GHG-intensive output
10 Fugitive emissions from fuel (solid, oil and gas)			AM0064	AM0023	AM0009	AM0074	AM0009
			ACM0008	AM0043	AM0037		AM0077
			AMS-III.W.	AMS-III.BI.	AM0077		
11 Fugitive emissions from production and consumption of halocarbons and SF ₆			AM0001	AM0035	AM0071		
			AM0078	AM0065	AM0092		
			AM0096	AM0079	AMS-III.AB.		
			AM0111	AM0092			
			AMS-III.X.	AMS-III.X.			
12 Solvent use							
13 Waste handling and disposal	ACM0022	AMS-III.AJ.	AM0073	AM0057			
	AM0112	AMS-III.BA.	ACM0001	AM0080			
	AMS-III.BJ.		ACM0010	AM0083			
			ACM0014	AM0093			
			AMS-III.G.	AM0112			
			AMS-III.H.	ACM0022			
			AMS-III.AX.	AMS-III.E.			
				AMS-III.F.			
				AMS-III.I.			
				AMS-III.Y.			
			AMS-III.AF.				
			AMS-III.AO.				
			AMS-III.BE.				
14 Land-use, land-use change and forestry						AR-AM0014	
						AR-ACM0003	
						AR-AMS0003	
						AR-AMS0007	
15 Agriculture			AM0073	AMS-III.A.	AMS-III.R.		
			ACM0010	AMS-III.AU.			
			AMS-III.D.	AMS-III.BE.			
			AMS-III.R.	AMS-III.BF.			
				AMS-III.BK.			

1.3. CATEGORIZATION BY APPLIED TECHNOLOGY TYPE/MEASURE (METHODOLOGY FAMILY TREES)

There have been distinct development phases of methodologies over time, leading to “families” when one methodology catalyzed the development of other methodologies.⁴ The figures below show the families of methodologies in form of family trees. They are designed as follows: Each methodology is denoted by a box showing its unique identification number. Methodologies that can be found in the same family tree deal with comparable technologies or measures.

- Methodologies for large-scale CDM project activities
- Methodologies for small-scale CDM project activities
- Methodologies for small and large-scale afforestation and reforestation (A/R) CDM project activities
- AM0000** Methodologies that have a particular potential to directly improve the lives of women and children

Figure VII-1. Methodologies for renewable electricity

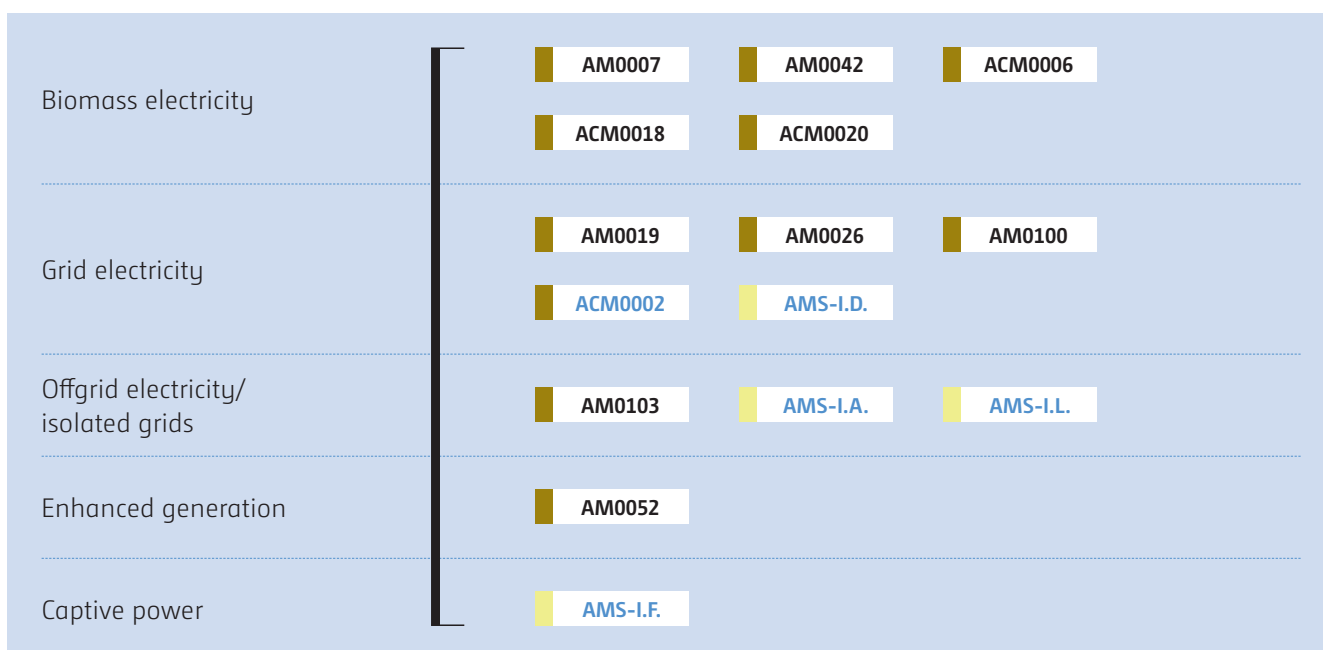

⁴ The concept of methodology families and family trees was initially adopted in the following guidebook: Understanding CDM Methodologies: A guidebook to CDM Rules and Procedures, written by Axel Michaelowa, Frédéric Gagnon-Lebrun, Daisuke Hayashi, Luis Salgado Flores, Philippe Crête and Mathias Krey, commissioned by the UK Department for Environment Food and Rural Affairs (© Crown Copyright 2007).

Figure VII-2. Methodologies for renewable energy (thermal or mechanical energy)

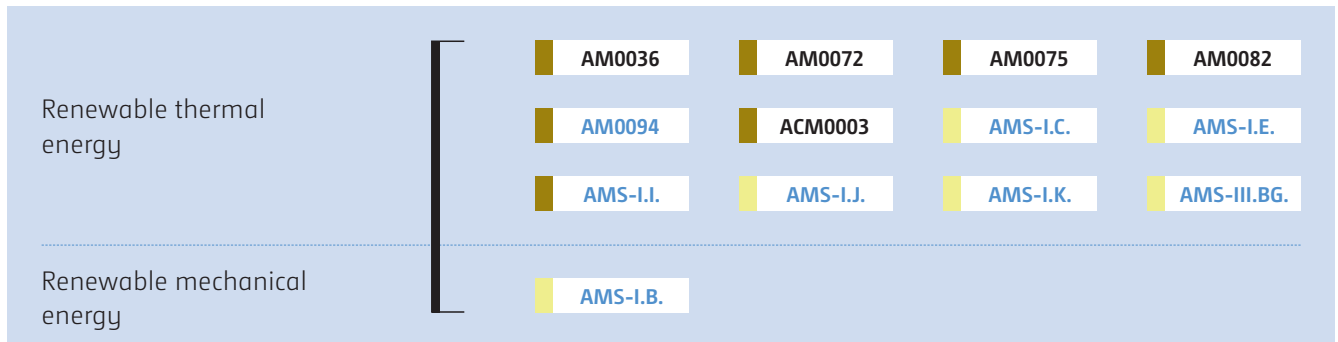

Figure VII-3. Methodologies for efficient or less-carbon-intensive fossil-fuel-fired power plants

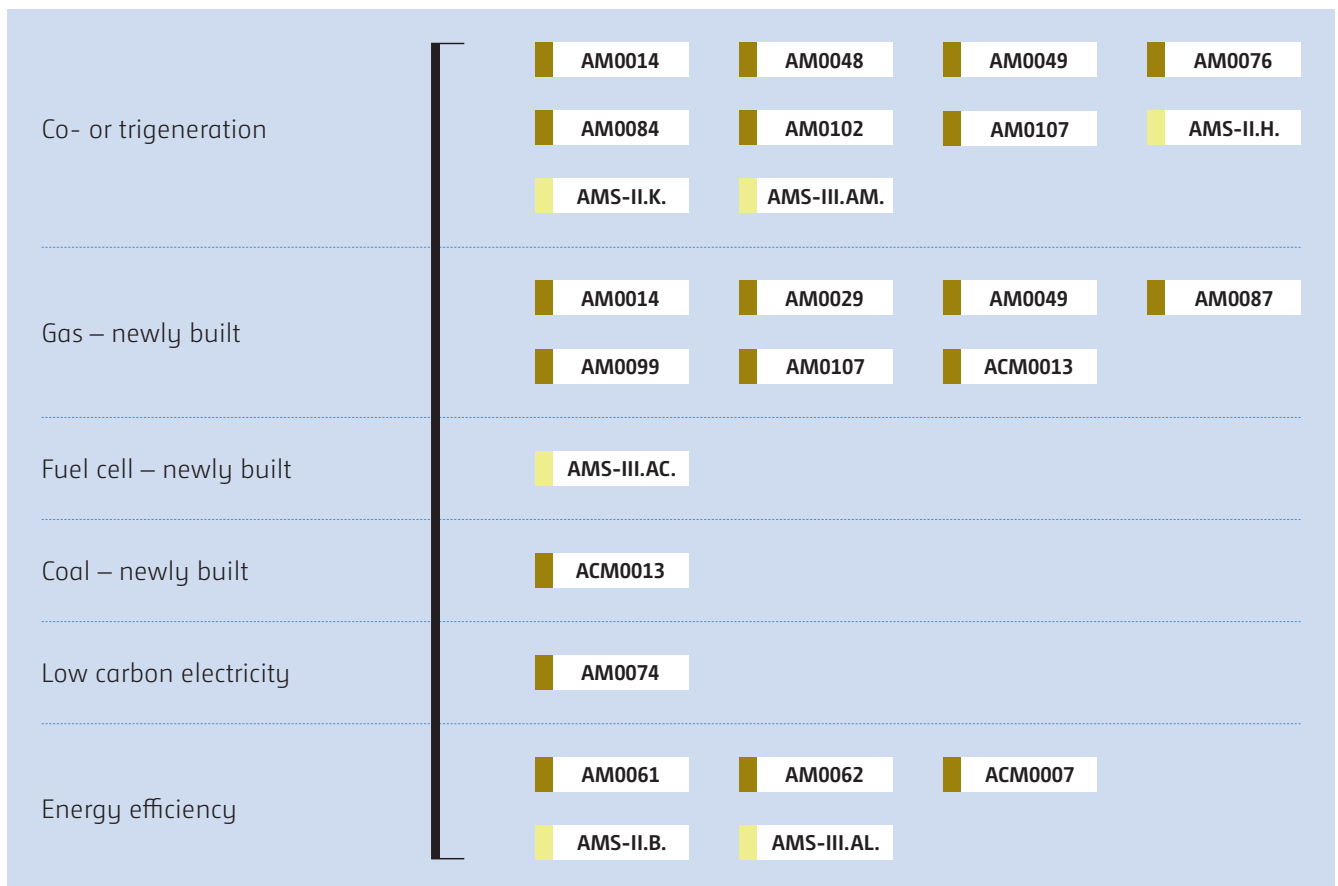

Figure VII-4. Methodologies for fuel switch

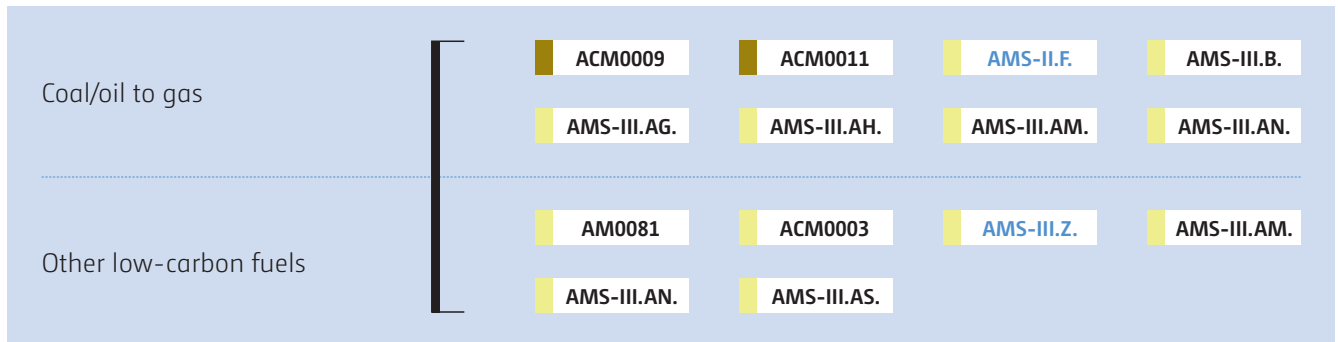

Figure VII-5. Methodologies for biofuel

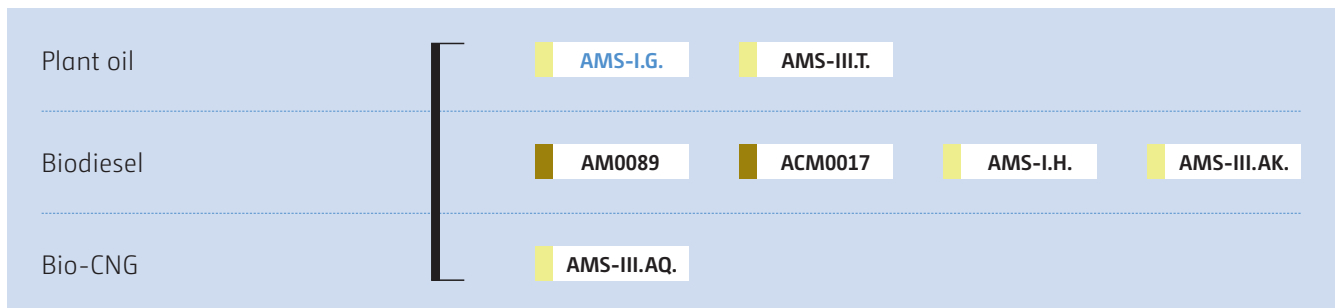

Figure VII-6. Methodologies for industrial energy efficiency



Figure VII-7. Methodologies for household & building energy efficiency



Figure VII-8. Methodologies for gas flaring and gas leak reduction

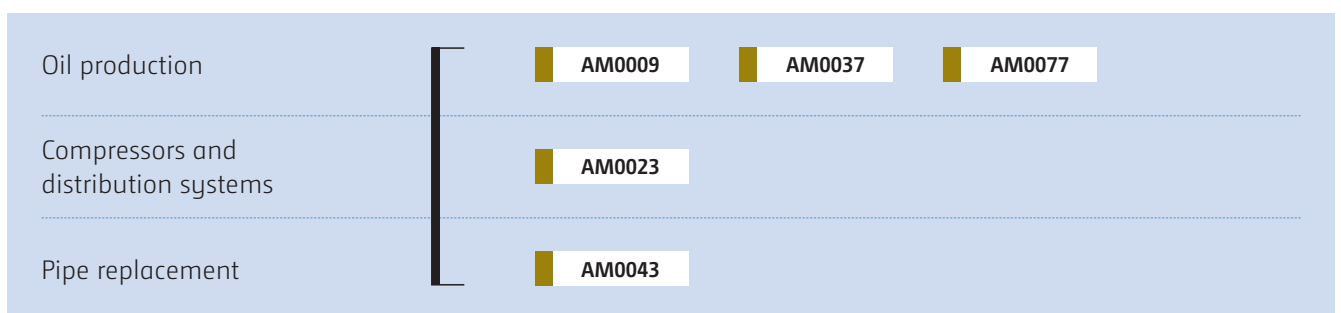

Figure VII-9. Methodologies for feedstock switch

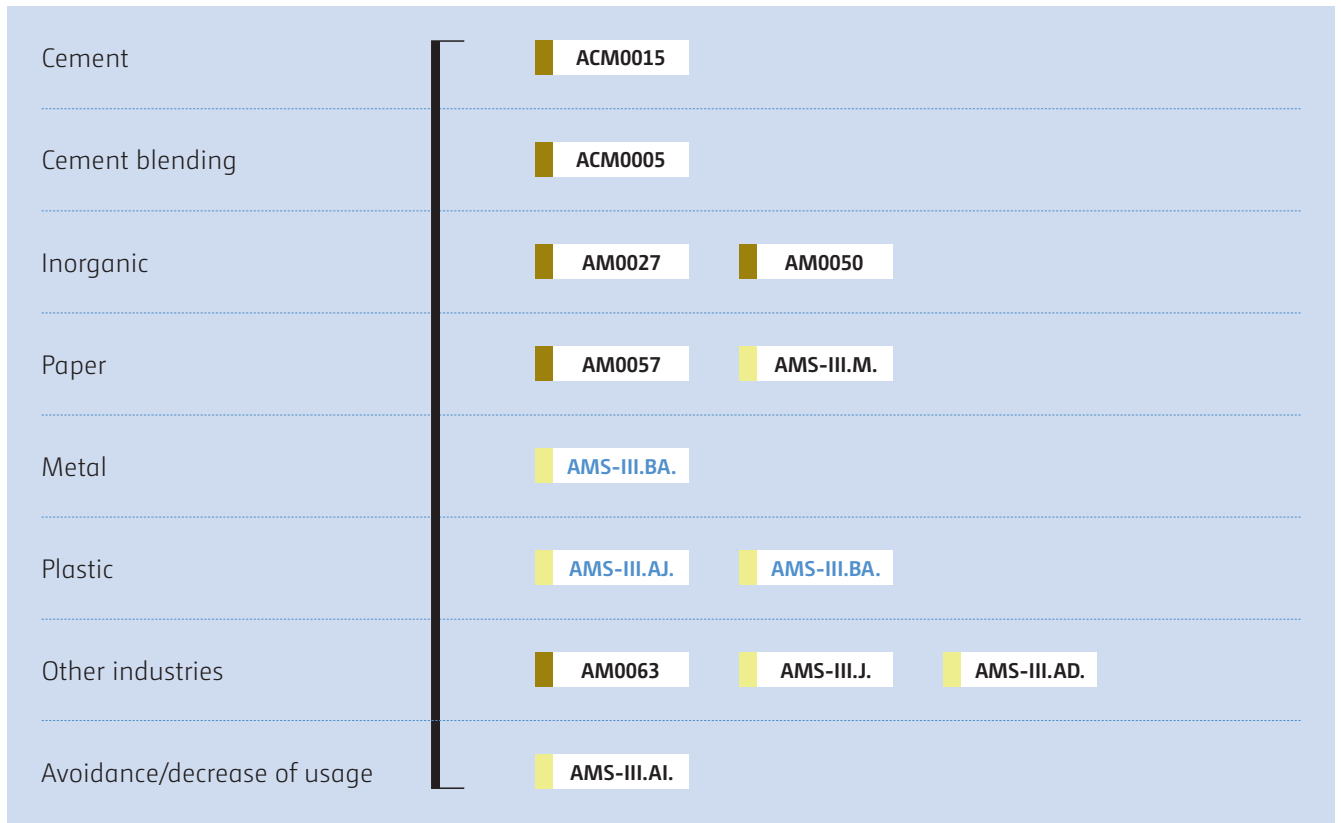

Figure VII-10. Methodologies for industrial gases

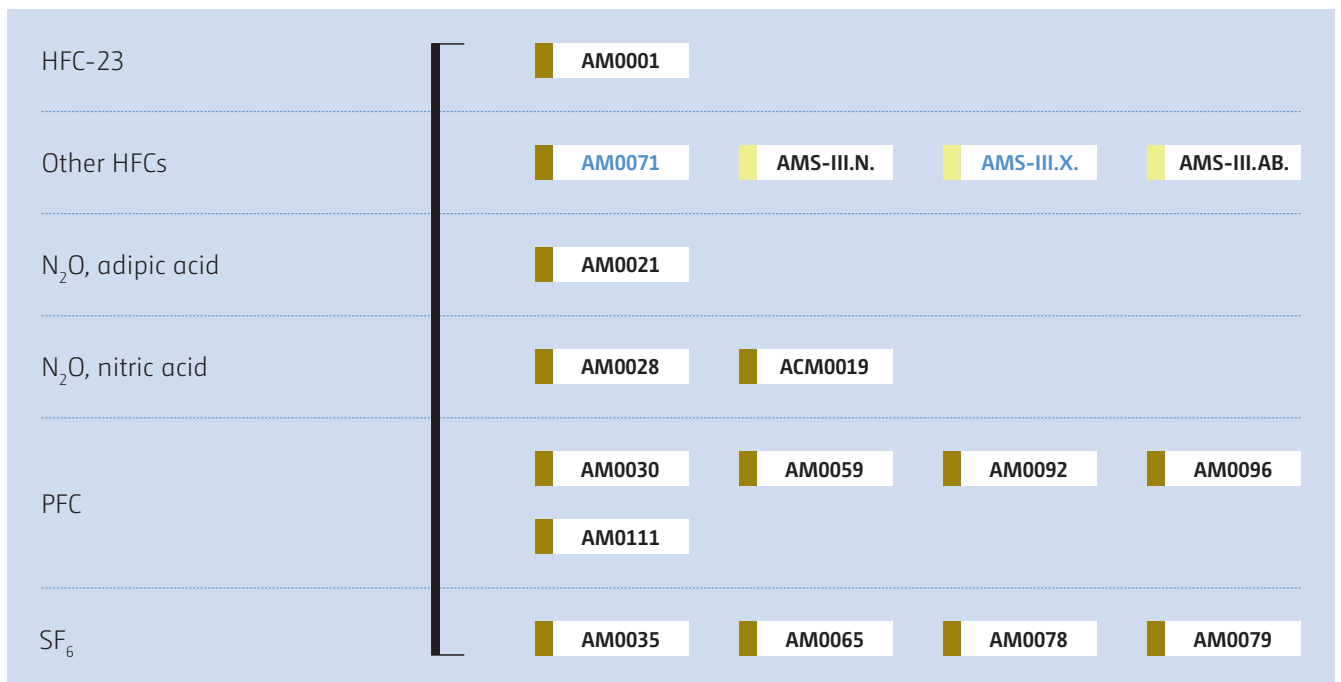

Figure VII-11. Methodologies for waste management and wastewater



Figure VII-12. Methodologies for transport

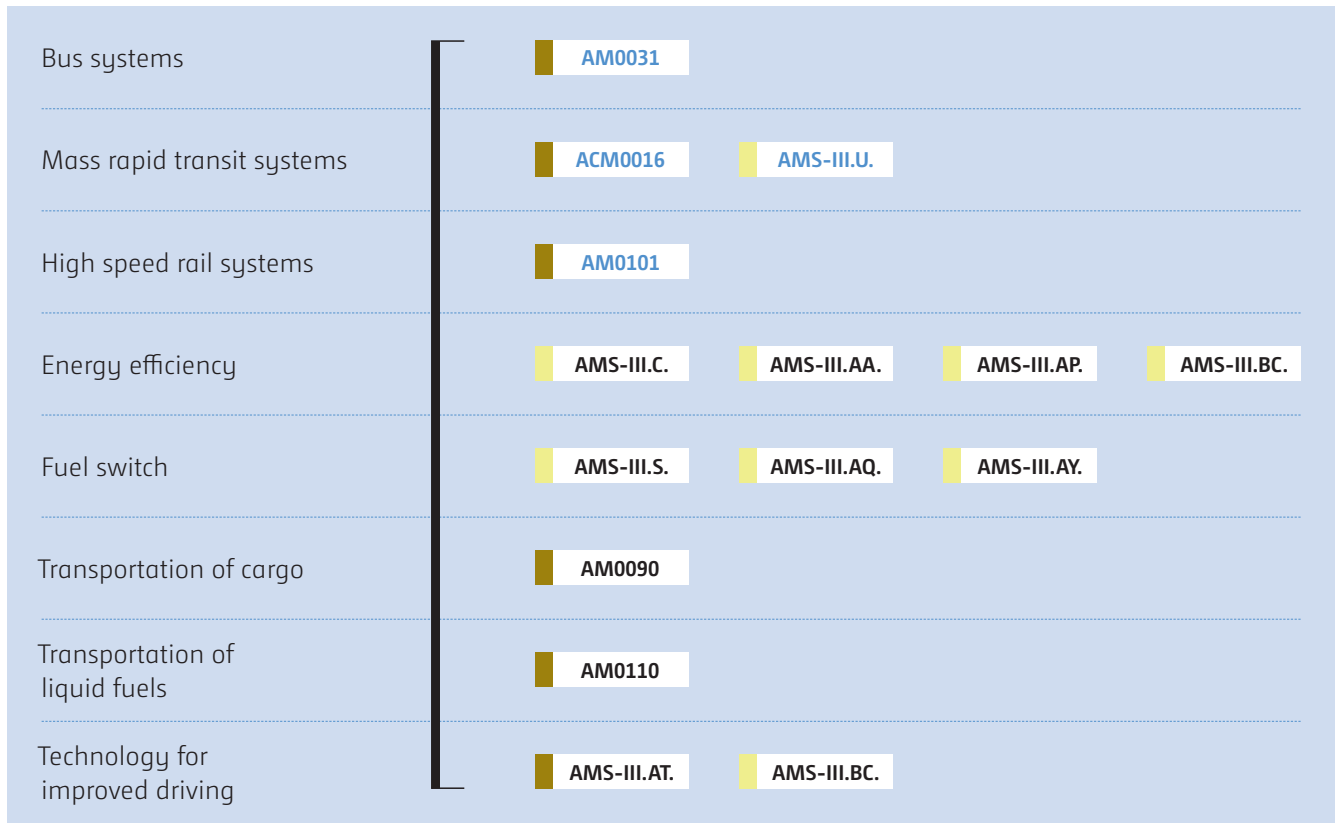
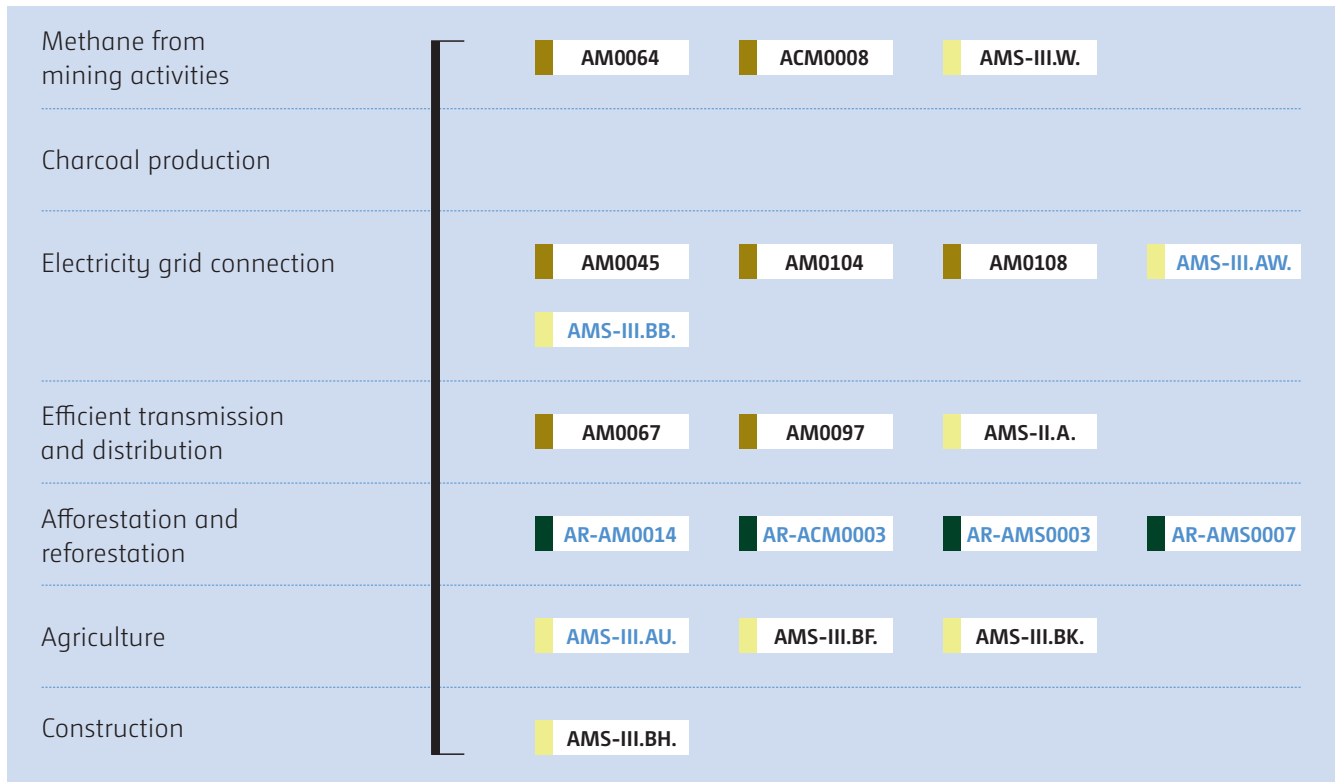

Figure VII-13. Other methodologies



1.4. PROGRAMMES OF ACTIVITIES

THE CONCEPT

In the CDM, a Programme of Activities (PoA) is defined as a voluntary coordinated action by a private or public entity that coordinates and implements any policy/measure or stated goal, which leads to emission reductions or net removals that are additional to any that would occur in the absence of the PoA, via an unlimited number of Component Project Activities (CPAs).

A CPA is a single measure, or a set of interrelated measures under a PoA, to reduce emissions or result in net removals, applied within a designated area.

A PoA is therefore like an “umbrella program”, which is registered by the Board. Individual CPAs that comply with the eligibility criteria specified in the PoA Design Document (PoA-DD) of the registered PoA can be included under this “umbrella” and actually generate emission reductions or net removals to benefit from carbon revenues.

BENEFITS

Compared to regular CDM project activities, PoAs have many benefits, particularly for less developed countries or regions. The process for the inclusion of individual CPAs under a registered PoA is considerably simplified and results in lower costs as compared to registration of regular project activities.

The main benefits of PoAs are:

- Transaction costs, investment risks and uncertainties for individual CPA participants are reduced;
- PoAs are managed by a designated Coordinating and Managing Entity (CME). The CME is responsible for most of the CDM process. Therefore, direct engagement of individual project developers in the CDM process is not required;
- Access to the CDM is extended to smaller project activities which would not be viable as regular project activities;
- Emission reductions can be continuously scaled up after PoA registration, since an unlimited number of CPAs can be added at a later stage;
- Many technologies with high co-benefits, e.g. household technologies, are supported by PoAs;

- Specific regional policy goals can be effectively supported by accessing carbon finance through PoAs;
- Monitoring/Verification of parameter values may be undertaken on a collective basis by utilizing a sampling approach;
- No registration fee is due for each CPA included after registration. Registration fees are based on the expected average emission reductions or net removals of the “actual case” CPAs submitted at the PoA registration.

PoA IN THE CDM PIPELINE

At the time of preparation of this edition of the Booklet, there were some sectors that have a higher proportion of PoAs in the CDM pipeline than regular project activities: energy efficiency demand side (sectoral scope 3), waste (sectoral scope 13) and solar energy (sectoral scope 1). Furthermore, out of the registered PoAs, it was observed that some methodologies were commonly used, such as:

- [ACM0002](#) Grid-connected electricity generation from renewable sources
- [AMS-I.C.](#) Thermal energy production with or without electricity
- [AMS-I.D.](#) Grid connected renewable electricity generation
- [AMS-II.G.](#) Energy efficiency measures in thermal applications of non-renewable biomass
- [AMS-II.J.](#) Demand-side activities for efficient lighting technologies
- [AMS-III.R.](#) Methane recovery in agricultural activities at household/small farm

1.5. STANDARDIZED BASELINES

A standardized baseline can be a positive list containing names of emission reduction activities that, if implemented in a given country or region, would be considered automatically additional under certain conditions. It can also be a baseline emission factor to be used for the purpose of estimation of baseline emissions (e.g. grid emission factor).

THE CONCEPT

A standardized baseline is a baseline established for a Party or a group of Parties to facilitate the calculation of emission reduction and removals and/or the determination of additionality for CDM project activities.

The following elements may be standardized by an approved standardized baseline:

- (a) Additionality; and/or
- (b) Baseline (baseline scenario and/or baseline emissions).

BENEFITS

The objective of standardized baselines is to scale up the abatement of GHG emissions while ensuring environmental integrity by potentially:

- Reducing transaction costs;
- Enhancing transparency, objectivity and predictability;
- Facilitating access to the CDM, particularly with regard to underrepresented project types and regions;
- Simplifying measuring, reporting and verification.

APPROVED STANDARDIZED BASELINES

ASB0001	Grid emission factor for the Southern African power pool
ASB0002	Fuel switch, technology switch and methane destruction in the charcoal sector of Uganda
ASB0003	Grid emission factor for the Republic of Uzbekistan
ASB0004	Technology switch in the rice mill sector of Cambodia
ASB0005	Grid emission factor for the Belize national power grid
ASB0006	Grid emission factor for the national power grid of Uganda

1.6. METHODOLOGIES ADDRESSING SUPPRESSED DEMAND

THE CONCEPT

Under the CDM, suppressed demand is defined as a “Scenario where future anthropogenic emissions by sources are projected to rise above current levels, due to the specific circumstances of the host Party”.

The concept of suppressed demand is included in some CDM methodologies to consider situations where key services such as lighting and heating, water supply, waste disposal and transportation are only available in quantities that are insufficient to meet basic human needs before the implementation of a CDM project activity. This can be due to low income and lack of technologies/infrastructures or resources for its implementation. The minimum service level required to fulfil generally accepted basic human needs is expected to be reached in the future as host countries develop their economies, hence incomes increase, resources improve and technologies/infrastructures are implemented.

For example, before the start of a CDM project activity, households may be devoid of access to an electricity grid and have only a few kerosene lamps in place that are operated for short time periods, or just use candles. Or they may not have access to clean drinking water and therefore boil a small quantity of water manually.

The concept of suppressed demand is included in CDM methodologies for the baseline calculation specifying a minimum service level. For example, the daily amount of drinking water availability recommended by the World Health Organization is used as baseline water provision volume for the methodology [AM0086](#) for water purification. In other methodologies such as [AMS-I.A.](#) and [AMS-I.L.](#), suppressed demand is taken into account by applying default emission factors for high emission technologies (e.g. kerosene lamps) assumed to be used due to the suppressed demand situation. In the methodology [ACM0022](#), a default emission factor for a shallow landfill can be used in the absence of an organized waste collection and disposal system. If suppressed demand were not included, baseline emissions would be so small that project activities would become unattractive under the CDM due to the small number of CERs generated.

Methodologies addressing the issue of suppressed demand are labelled with a specific icon “Suppressed demand”, put on the top right of the summary sheet.

BENEFIT

The consideration of suppressed demand allows host countries to improve life conditions by implementing CDM project activities.

Another benefit is the reduction of transaction costs for CDM project developers. Detailed data gathering to establish parameter values for baseline emission calculations may not be necessary as CDM methodologies that address the issue of suppressed demand usually include default values that are representative for the specific service level, such as the amount of kerosene used for lighting.

METHODOLOGIES ADDRESSING SUPPRESSED DEMAND

AM0086	Installation of zero energy water purifier for safe drinking water application
AM0091	Energy efficiency technologies and fuel switching in new and existing buildings
ACM0022	Alternative waste treatment processes
AMS-I.A.	Electricity generation by the user
AMS-I.L.	Electrification of rural communities using renewable energy
AMS-II.R.	Energy efficiency space heating measures for residential buildings
AMS-III.F.	Avoidance of methane emissions through composting
AMS-III.AR.	Substituting fossil fuel based lighting with LED/CFL lighting systems
AMS-III.AV.	Low greenhouse gas emitting safe drinking water production systems
AMS-III.BB.	Electrification of communities through grid extension or construction of new mini-grids

1.7. METHODOLOGIES HAVING BENEFITS FOR WOMEN AND CHILDREN

The dual goals of the CDM are to promote sustainable development and reduce GHG emissions or enhance GHG removals. The outcomes of a CDM project activity should therefore directly or indirectly improve the living conditions of all people.

What has been highlighted in the booklet is that some methodologies have a particular potential to directly improve the lives of women and children effected by the project activity. These methodologies are labelled with a specific icon “Women and children”, put on the top right of the summary sheet.

The criteria used to label these methodologies as having particular benefits for women and children are the potential to:

- increase access to affordable household fittings and appliances (e.g. light globes, refrigerators);
- optimize tasks typically undertaken by women or children (e.g. fuel wood gathering, cooking, water collection);
- improve the living environment of women and children (e.g. better air quality, heating, lighting); or
- utilize community-based participatory approaches, that give women and children an opportunity to learn about the projects and contribute to decision making processes.

In the case of A/R CDM project activities, this icon is also indicated for project activities that generate new local employment opportunities because these positions are often filled by women.

It is important to note that a methodology that has not been labelled with this icon will not impact adversely on women and children.

The following publication, “CDM and Women”, accessible on the CDM website, further highlights some women-friendly methodologies and aims to encourage project developers to consider the CDM when planning projects to help empower and improve women’s lives.

1.8. INTRODUCTION TO METHODOLOGY SUMMARY SHEETS

The methodology summary sheets are distinguished as being for large-scale and small-scale CDM project activities, as well as large-scale and small-scale A/R CDM project activities. Each methodology summary sheet has the sections as follows:

TYPICAL PROJECT(S) APPLICABLE TO THE METHODOLOGY

Project activities for which the methodology is applicable are described. Practical examples are mentioned for better understanding of the purpose of the specific methodology.

TYPE(S) OF GHG EMISSION MITIGATION ACTION

This refers to the type of mitigation activity presented in the methodology categorization table (section 1.2. above). The type of mitigation action, such as fuel switch or energy efficiency, is briefly described.

IMPORTANT CONDITIONS UNDER WHICH THE METHODOLOGY IS APPLICABLE

Methodologies are only applicable under particular conditions and the most relevant conditions are listed in this section. However, not all conditions can be listed and it is important to consult the full text of each methodology.

IMPORTANT PARAMETERS THAT NEED TO BE DETERMINED OR MONITORED

In order to calculate emission reductions or net removals of a project activity, certain parameters have to be determined at the beginning when the project activity is validated and various parameters have to be monitored during the operation of the project activity. Therefore this section is divided into parameters “at validation” and parameters “monitored”. In addition, some methodologies require checking of specific conditions or parameters to prove that applicability conditions are met.









VISUAL DESCRIPTION OF BASELINE AND PROJECT SCENARIOS

An important feature of the booklet is the use of diagrams made of icons to illustrate the baseline and project scenarios. These diagrams enable readers to quickly grasp the scope of the methodology.

The baseline scenario represents the situation that would occur in the absence of the project activity. The project scenario refers to the situation that is achieved by the implementation of the project activity. Complex scenarios cannot be displayed by a simplified diagram. Therefore, the simplified diagrams focus on the main activity that results in emission reductions or net removals. The diagrams do not replace the necessity to consult the full methodology text.

A list of icons used in the booklet is given in chapter II. Some exemplifications of diagrams are presented below.

EXEMPLIFICATION OF DIAGRAMS

	<p>Full intensity in the baseline scenario is depicted with bold colour.</p>
	<p>Reduced, decreased intensity in the project activity is depicted with pale colour.</p>
	<p>Avoidance and replacement is depicted with crossed icons.</p>
	<p>A carbon-intensive fossil fuel is used in the baseline scenario. Instead of the carbon-intensive fossil fuel, a less-carbon-intensive fossil fuel is used due to the project activity.</p>
	
	<p>A less-efficient technology is used in the baseline scenario. A more-efficient technology is used due to the project activity.</p>
	
	<p>Activities in the baseline scenario result in GHG emissions. Less GHG emissions are occurring due to the project activity.</p>
	

EXEMPLIFICATION OF DIAGRAMS

	<p>Activities in the baseline scenario result in GHG emissions. These GHG emissions are avoided due to the project activity.</p>
	<p>Electricity is either produced by power plants connected to the grid or a captive power plant using fossil fuel.</p>
	<p>Biomass is either left to decay or burned in an uncontrolled manner.</p>
	<p>The project boundary encompasses all emissions of GHG under the control of the project participants that are significant and reasonably attributable to the CDM project activity. Due to the simplification of the diagrams, please consult each methodology for the detailed delineation of the project boundary.</p>
<p>Baseline situation</p>	
<p>Project situation</p>	































CDM Methodology Booklet

Chapter II











ICONS, ABBREVIATIONS AND GLOSSARY

2.1. ICONS USED IN THIS BOOKLET

	<p>Afforestation/reforestation areas Small afforestation/reforestation areas.</p>		<p>Catalysis Catalysis of substances (i.e. GHGs) in order to convert them into substances with less or no GWP.</p>
	<p>Agricultural activity Production of crops or livestock.</p>		<p>Cement Products such as clinker, cement, lime or bricks.</p>
	<p>Agricultural land Land with crops on solid ground. Also plantations not meeting definition of forest.</p>		<p>Charcoal production Charcoal production activity.</p>
	<p>Air</p>		<p>Commercial Consumer Commercial consumer, e.g. industrial or institutional consumer.</p>
	<p>Airplane Any kind of airplane-based transport.</p>		<p>Consumer Residential or commercial consumer.</p>
	<p>Animal grazing Grazing livestock in pasture land or any other land.</p>		<p>Contaminated land May indicate chemically polluted land (e.g. mine spoils) or naturally hostile land (e.g. naturally occurring salinity or alkalinity). The specific type is shown in the icon caption.</p>
	<p>Biomass Unless stated otherwise, renewable biomass is implied. Types of biomass include residues, plant oil, wood.</p>		<p>Controlled burning Any kind of combustion or decomposition in a controlled manner to dispose combustible substances. Also combustion to produce feedstock such as CO₂ or heat.</p>
	<p>Buildings Any kind of building.</p>		<p>Cooling</p>
	<p>Burning Uncontrolled burning of biomass, flaring or venting of waste gas.</p>		<p>Data centre</p>
	<p>Bus Any kind of bus-based transport.</p>		<p>Degraded land Degraded land, e.g. with cracks (not roots), no vegetation on top. This symbol can be grouped with any of the land covers below to depict a combination (e.g. “degraded grassland” by showing both “land” and “grassland”)</p>
	<p>Car Any kind of car-based transport.</p>		

	<p>Disposal Any kind of disposal. E.g. landfilling.</p>		<p>Fossil fuel Any kind of fossil fuel used for combustion. Can be gaseous, liquid or solid. E.g. natural gas, fuel oil, coal.</p>
	<p>Drinking water</p>		<p>Fuelwood collection Collecting fuelwood without full-tree harvest.</p>
	<p>Electricity</p>		<p>Gas Any kind of combustible gas. E.g. natural gas, methane, biogas, landfill gas.</p>
	<p>Electricity distribution grid This icon is used to depict an electricity distribution system and is used when generated electricity is/ has to be supplied to the electricity grid or if the project activity occurs directly within the electricity distribution system.</p>		<p>Gas distribution system Any kind of gas distribution system. E.g. natural gas pipeline system.</p>
	<p>Electricity grid This icon is used to depict all (fossil-fuel-fired) power plants connected and providing electricity to the grid (e.g. national or regional grid).</p>		<p>Grassland Grass on ground without cracks.</p>
	<p>Energy Any kind of energy. This icon is used, if different types of energy are depicted. E.g. electricity, heat, steam or mechanical energy.</p>		<p>Greenhouse gas emissions Emissions of greenhouse gases, i.e.: Carbon dioxide (CO₂) Methane (CH₄) Nitrous oxide (N₂O) Hydrofluorocarbons (HFCs) Perfluorocarbons (PFCs) Sulphur hexafluoride (SF₆). Where applicable, the specific GHG is presented in the icon caption.</p>
	<p>Energy distribution system Any kind of energy distribution system. E.g. electricity grid or heat distribution system.</p>		<p>Harvesting Harvesting activity.</p>
	<p>Energy generation Any kind of plant, facility or equipment used to generate energy. This icon represents any co- or tri-generation system as well as systems to provide mechanical energy. The icon is also used, if either electricity or heat are produced.</p>		<p>Heat Any kind of thermal energy. E.g. steam, hot air, hot water.</p>
	<p>Exploitation Any kind of exploitation activity such as mining activities, oil and gas production.</p>		<p>Heat distribution system Any kind of heat distribution system. E.g. steam system, district heating system.</p>
	<p>Fixation of CO₂ in Biomass Fixation of atmospheric CO₂ from the atmosphere in biomass through the process of photosynthesis</p>		<p>Heat generation Any kind of plant, facility or equipment used to generate heat. This includes fossil-fuel-fired boilers to generate steam, incinerators, but also small applications such as radiators, cookers and ovens.</p>

 <p>Material</p> <p>Input or output material Any kind of material. Can be gaseous, liquid or solid. E.g. raw materials, substances used for production, products such as plastics. This icon is also used if a GHG such as CO₂ is used as feedstock.</p>	 <p>Power plant</p> <p>Any kind of plant, facility or equipment used to produce electricity. This includes fossil-fuel-fired power plants, renewable power plants such as hydro power plants, but also (small) photovoltaic systems.</p>
 <p>Application</p> <p>Land application The material (e.g. sludge) is applied to land.</p>	 <p>Production</p> <p>The output of the production can be specified in the icon caption. E.g. aluminium, iron, cement, refrigerators.</p>
 <p>Fossil Fuel</p> <p>Less-carbon-intensive fossil fuel Any kind of less-carbon-intensive fossil fuel used for combustion. E.g. natural gas.</p>	 <p>HFC Refrigerant</p> <p>Refrigerant Refrigerant that contains HFC.</p>
 <p>Lighting</p> <p>Lighting Any kind of lighting equipment such as incandescent light bulbs, compact florescent lamps.</p>	 <p>Refrigerator</p> <p>Refrigerators and chillers Any kind of refrigerator or chiller.</p>
 <p>Livestock</p> <p>Livestock Any kind of livestock.</p>	 <p>Release</p> <p>Release Any kind of release of substances or energy without using the substance or the energy content of the substances.</p>
 <p>Losses</p> <p>Losses Any kind of losses from leaks in pipe systems and other distribution systems.</p>	 <p>Consumer</p> <p>Residential Consumer Residential consumer, e.g. households.</p>
 <p>Manure</p> <p>Manure Manure from livestock.</p>	 <p>Sand/Barren</p> <p>Sand dunes or barren land Sand dunes or barren land without vegetation.</p>
 <p>Mechanical</p> <p>Mechanical energy</p>	 <p>Seeds</p> <p>Any type of seeds.</p>
 <p>Milk</p> <p>Milk production</p>	 <p>Settlement</p> <p>Settlement land Land within settlements (parks, lawns, etc.) or along infrastructure (roads, powerlines, railways, waterways, etc.).</p>
 <p>Motorcycle</p> <p>Motorcycle Any kind of motorcycle-based transport.</p>	 <p>Ship</p> <p>Ship Any kind of transport based on ships or barges.</p>
 <p>Oil</p> <p>Oil Oil of fossil origin. E.g. crude oil.</p>	 <p>Shrub/trees</p> <p>Shrub and/or single tree vegetation Non-forest woody vegetation: shrubs and single trees on "solid" ground (without cracks).</p>
 <p>Planting</p> <p>Planting or seeding Afforestation/reforestation activity by planting, seeding or other measures.</p>	

 Suppressed demand	Suppressed demand Methodologies that address the issue of suppressed demand.
 Technology	Technology Any kind of technology, equipment, appliance.
 Train	Train Any kind of train-based transport.
 Treatment	Treatment Any kind of treatment of waste or materials, e.g. production of RDF from municipal waste.
 Treatment	Treatment Any kind of treatment of wastewater or manure, e.g. lagoons, pits, aerobic treatment systems.
 Truck	Truck Any kind of truck-based transport.
 Upgrade	Upgrade Any type of upgrade. Can be retrofitting of existing equipment or installation of more-advanced technology to displace existing less-advanced equipment. E.g. replacement of incandescent light bulbs by compact fluorescent lamps. Also applicable to upgrade agricultural activity processes.
 Waste	Waste Any kind of waste. Can be gaseous, liquid or solid. The specific substance can be specified in the icon caption.
 Water	Water Any kind of water. E.g. drinking water, waste water.
 Wetland	Wetland Lands with wet to moist soil, e.g. swamp or peatland.
 Women and children	Women and children Project activities using these methodologies have a particular potential to directly improve the lives of women and children.

2.2. ABBREVIATIONS USED IN THIS BOOKLET

%	Percent
°C	Degree Celsius
A/R	Afforestation/ Reforestation
ACM	Approved Consolidated Methodology
AL	Aluminium
AM	Approved Methodology
AMS	Approved Methodology for Small-scale CDM project activities
AOR	Ammonia Oxidation Reactor
Board	CDM Executive Board (also referred to as EB)
BRT	Bus Rapid Transit
BSG	Baseline Sample Group
CACO ₃	Calcium Carbonate
CCHP	Trigeneration (Combined Cooling, Heating and Power generation)
CDD	Cooling Degree Days
CDM	Clean Development Mechanism
CDR	Carbon Dioxide Recovery
CER	Certified Emission Reduction
(CF ₃ CF ₂ C(O))	Perfluoro-2-methyl-3-pentanone
CF(CF ₃) ₂	
CFC	Chlorofluorocarbons
CFL	Compact Fluorescent Lamps
CH ₄	Methane
CHP	Cogeneration (Combined Heat and Power generation)
CM	Combined Margin
CNG	Compressed Natural Gas
CO ₂	Carbon Dioxide
COD	Chemical Oxygen Demand
COG	Coke Oven Gas
COP	Coefficient of Performance
CWPB	Centre Worked Pre-Baked
DC	Direct Cool
DME	Dimethyl ether
DMI	Dry Matter Intake
DOE	Designated Operational Entity
DOM	Dead Organic Matter
DRI	Direct Reduced Iron
DSS	Decision Support System
DWW	Dewatered Wastewater
FF	Frost Free
GHG	Greenhouse Gas
GIEE	Gas Insulated Electrical Equipment
GIS	Geographic Information System
GWh	Gigawatthours
GWP	Global Warming Potential
HDD	Heating Degree Days

HDPE	High Density Polyethylene
HFC	Hydrofluorocarbon
HPO (process)	Hydroylamin-Phosphat-Oxim (process)
HRSG	Heat Recovery Steam Generator
HSS	Horizontal Stud Soederberg
IAI	International Aluminium Institute
ICL	Incandescent Lamps
IEC	International Electronic Commission
IG	Intermediate Gas
IPCC	Intergovernmental Panel on Climate Change
ISO	International Organization for Standardization
kg	Kilogramme
km	Kilometre
kV	Kilovolt
kt	Kiloton
LCD	Liquid Crystal Display
LDPE	Low Density Polyethylene
LFG	Landfill gas
LNG	Liquefied Natural Gas
LPG	Liquefied Petroleum Gas
LSC	Large-scale
m	Metre
m ²	Square metre
m ³	Cubic metre
MgCO ₃	Magnesium Carbonate
MRG	Methane Rich Gas
MSW	Municipal Solid Waste
MW	Megawatt
N ₂ O	Nitrous Oxide
ODP	Ozone Depleting Potential
PDD	Project Design Document
PFC	Perfluorocarbon
PFPB	Point Feeder Pre-Baked
PoA	Programme of Activities
PoA-DD	Programme of Activities Design Document
PSG	Project Sample Group
P-U	Power-Voltage (characteristic curve)
PUF	Polyurethane Foam
PV	Photovoltaic
RDF	Refuse-Derived Fuel
RHF	Rotary Hearth Furnace
SB	Stabilized Biomass
SF ₆	Sulphur Hexafluoride
SiMn	Silicomanganese
SO ₂	Sulphur Dioxide
SOC	Soil Organic Carbon
SSC	Small-scale
SWDS	Solid Waste Disposal Site
SWPB	Side Worked Pre-Baked
TG	Tailgas
VAM	Ventilation Air Methane
VSS	Vertical Stud Soederberg
W	Watt

2.3. GLOSSARY

GENERAL GLOSSARY

Explanations on general terminologies used in this booklet are listed below. More definitions are given in the Glossary of CDM terms. For terminologies specific to a certain methodology, please refer to the definition section of the full methodology. A specific glossary for A/R methodologies follows this list.

Additional/Additionality	The effect of a CDM project activity or CPA to reduce anthropogenic GHG emissions below the level that would have occurred in the absence of the CDM project activity or CPA. Whether or not a CDM project activity or CPA is additional is determined in accordance with the CDM rules and requirements.
Afforestation	The direct human-induced conversion of land that has not been forested for a period of at least 50 years to forested land through planting, seeding and/or the human-induced promotion of natural seed sources.
Capacity addition	A capacity addition is an increase in the installed power generation capacity of an existing power plant through the installation of a new power plant beside the existing power plant/units, or the installation of new power units, additional to the existing power plant/units. The existing power plant/units continue to operate after the implementation of the project activity.
Capacity increase	A (minor) increase in the design capacity due to the installation of improved equipment compared to the original design.
Captive generation	Captive generation is defined as generation of electricity in a power plant that supplies electricity only to consumer(s) or multiple consumers and not to the electricity grid. The consumer(s) or multiple consumers are either located directly at the site of the power plant or are connected through dedicated electricity line(s) with the power plant but not via the electricity grid.
Baseline scenario	The scenario for a CDM project activity or CPA that reasonably represents the anthropogenic emissions by sources of GHG that would occur in the absence of the proposed CDM project activity or CPA.
Biomass	Non-fossilized and biodegradable organic material originating from plants, animals and micro-organisms, including: (a) Biomass residue; (b) The non-fossilized and biodegradable organic fractions of industrial and municipal wastes; and (c) The gases and liquids recovered from the decomposition of non-fossilized and biodegradable organic material.
Biomass, non-renewable	Biomass not fulfilling the conditions of renewable biomass is considered as non-renewable.
Biomass, renewable	Biomass is "renewable" if one of five conditions is met. These are described in the Glossary of CDM terms.
Biomass, residues	Non-fossilized and biodegradable organic material originating from plants, animals and micro-organisms which is a by-product, residue or waste stream from agriculture, forestry and related industries.
Carbon sequestration	Carbon sequestration is defined as a biological, chemical or physical process of removing carbon from the atmosphere and depositing it in a reservoir.
Cogeneration	A cogeneration plant is a heat and power generation plant in which at least one heat engine simultaneously generates both heat and power. If power, heat and cooling is provided at the same time, the term tri-generation is used instead of co-generation.
Degraded land	Land degradation is a long-term decline in ecosystem function and productivity and measured in terms of net primary productivity. All forms of land degradation will ultimately lead to a reduction of soil fertility and productivity. The general effect is reduced plant growth, which in turn causes loss of protective soil cover and increased vulnerability of soil and vegetation to further degradation (e.g. erosion).
Emission factor	An emission factor is defined as the measure of the average amount of GHG emitted to the atmosphere by a specific process, fuel, equipment, or source.

Energy efficiency	Energy efficiency is defined as the improvement in the service provided per unit power, that is, project activities which increase unit output of traction, work, electricity, heat, light (or fuel) per MW input are energy efficiency project activities.
Feedstock	Raw material used in manufacture. Can be gaseous, liquid or solid.
Fossil fuel	Fuels formed by natural resources such as anaerobic decomposition of buried dead organisms (e.g. coal, oil, and natural gas).
Greenfield	Greenfield activities refer to the construction of a new facility at a location where previously no facility exists. E.g. construction of new power plant where previously no power generation activity exists.
Greenhouse gas	A greenhouse gas listed in Annex A to the Kyoto Protocol, unless otherwise specified in a particular methodology.
Grid	The grid or electricity system is an interconnected network for delivering electricity from suppliers to consumers. It includes all power plants that are physically connected through transmission and distribution lines.
Industrial gases	Greenhouse gases originating from chemical production processes that are not naturally occurring. In addition, N ₂ O from chemical production processes is included in this group of greenhouse gases.
Land use, land-use change and forestry	A GHG inventory sector that covers emissions and removals of GHG resulting from direct human-induced land use, land-use change and forestry activities.
Leakage	The net change of anthropogenic emissions by sources of GHG which occurs outside the project boundary, and which is measurable and attributable to the CDM project activity or PoA, as applicable.
Low-carbon electricity	Electricity that is generated with a less-GHG-intensive fuel than in the baseline (e.g., natural gas in the project, and coal in the baseline).
Merit order	A way of ranking available power plants in ascending order of their short-run marginal costs of production, so that those with the lowest marginal costs are the first ones to be brought on line to meet demand and the plants with the highest marginal costs are the last to be brought on line.
Project boundary	The significant anthropogenic GHG emissions by sources under the control of the project participant that are reasonably attributable to the CDM project activity or CPA, as determined in accordance with the CDM rules and requirements.
Reforestation	The direct human-induced conversion of non-forested land to forested land through planting, seeding and/or the human-induced promotion of natural seed sources, on land that was forested but has been converted to non-forested land.
Renewable energy	Energy that comes from natural resources such as sunlight, wind, rain, tides, and geothermal heat, which are renewable (naturally replenished).
Retrofit	To modify existing industrial, commercial and residential facilities, automobiles, energy conversion systems etc. which are already in service using new, improved or more efficient parts and equipment developed or made available after the time of original manufacture or installation of the facility, automobiles, energy conversion systems etc., in accordance with any guidance from the Board on the lifetime of parts and equipment.
Sectoral scope	The category of GHG source sectors or groups of activities that apply to CDM project activities or PoAs. It is based on the sectors and source categories set out in Annex A to the Kyoto Protocol. A CDM project activity or PoA may fall within more than one sectoral scope. Sectoral scopes are used for the accreditation of DOEs. A full list of sectoral scopes, related methodologies and DOEs is available at: https://cdm.unfccc.int/DOE/scopes.html
Waste energy	A by-product gas/heat/pressure from machines and industrial processes having potential to provide usable energy, which is currently wasted. For example gas flared or released into the atmosphere, the heat or pressure not recovered (therefore wasted).

SPECIFIC GLOSSARY TO A/R METHODOLOGIES

Above-ground biomass⁵	All living biomass above the soil including stem, stump, branches, bark, seeds, and foliage as well as herbaceous vegetation.
Additional/Additionality	The effect of the A/R CDM project activity or CPA to increase actual net GHG removals by sinks above the sum of the changes in carbon stocks in the carbon pools within the project boundary that would have occurred in the absence of the A/R CDM project activity or CPA. Whether or not an A/R CDM project activity or CPA is additional is determined in accordance with the CDM rules and requirements.
Agroforestry	Growing of both trees and agricultural / horticultural crops on the same piece of land.
Allometric biomass equations	Regression equations calculating biomass based on measured parameters of a tree (or shrub). E.g. quantifying the relationship between above-ground tree biomass and the diameter at breast height and tree height of a specific tree species.
Baseline scenario	The scenario for an A/R CDM project activity or CPA that reasonably represents the sum of the changes in carbon stocks in the carbon pools within the project boundary that would occur in the absence of the A/R CDM project activity or CPA.
Below-ground biomass⁵	All living biomass of roots. Fine roots of less than (suggested) 2 mm diameter are often excluded because these often cannot be distinguished empirically from soil organic matter or litter.
Biomass expansion factor	Ratio of total stand biomass to stand (merchantable) volume (e.g. as derived from forest yield tables).
Deadwood⁵	Includes all non-living woody biomass not contained in the litter, either standing, lying on the ground, or in the soil. Dead wood includes wood lying on the surface, dead roots, and stumps larger than or equal to 10 cm in diameter or any other diameter used by the country.
Degraded land	Land degradation is a long-term decline in ecosystem function and productivity and measured in terms of net primary productivity. All forms of land degradation will ultimately lead to a reduction of soil fertility and productivity. The general effect is reduced plant growth, which in turn causes loss of protective soil cover and increased vulnerability of soil and vegetation to further degradation (e.g. erosion).
Forest	A minimum area of land of 0.05–1.0 hectare with tree crown cover (or equivalent stocking level) of more than 10–30 per cent with trees with the potential to reach a minimum height of 2–5 metres at maturity in situ and may include: (a) Either closed forest formations where trees of various storeys and undergrowth cover a high proportion of the ground or open forest; (b) Young natural stands and all plantations which have yet to reach a crown density of 10–30 per cent or tree height of 2–5 metres; (c) Areas normally forming part of the forest area which are temporarily unstocked as a result of human intervention such as harvesting or natural causes but which are expected to revert to forest. The definition of forest becomes applicable to a Party when: (a) For an Annex I Party, the Party selects a single minimum tree crown cover value between 10 and 30 per cent, a single minimum land area value between 0.05 and 1 hectare and a single minimum tree height value between 2 and 5 metres, as provided under paragraph 16 of the Annex to decision 16/CMP.1; (b) For a non-Annex I Party, the Party selects a single minimum tree crown cover value between 10 and 30 per cent, a single minimum land area value between 0.05 and 1 hectare and a single minimum tree height value between 2 and 5 metres, as provided under paragraph 8 of the Annex to decision 5/CMP.1.
Harvesting	Cutting and removal of trees from forests for timber or other uses. In sustainable forestry, harvesting is followed by planting or natural regeneration of the forest.

⁵ According to Intergovernmental Panel on Climate Change Good Practice Guidance for Land Use, Land-Use Change and Forestry, table 3.2.1 on page 3.15

Leakage	Increase in GHG emissions by sources or decrease in carbon stock in carbon pools which occurs outside the boundary of an A/R CDM project activity or PoA, as applicable, which is measurable and attributable to the A/R CDM project activity or PoA, as applicable.
Litter⁶	Includes all non-living biomass with a diameter less than a minimum diameter chosen by the country (for example 10 cm), lying dead, in various states of decomposition above the mineral or organic soil. This includes the litter, fomic, and humic layers. Live fine roots (of less than the suggested diameter limit for below-ground biomass) are included in litter where they cannot be distinguished from it empirically.
Non-forest woody vegetation	Woody vegetation which does not reach the threshold for forest definition, e.g. single trees and shrubs.
Project boundary	The geographic delineation of the A/R CDM project activity or CPA under the control of the project participant as determined in accordance with the CDM rules and requirements.
Silvopastoral activities	Integration of trees with forage and livestock production (grazing) on forest land.
Soil organic carbon⁶	Includes organic carbon in mineral and organic soils (including peat) to a specified depth chosen by the country and applied consistently through the time series. Live fine roots (of less than the suggested diameter limit for below-ground biomass) are included with soil organic matter where they cannot be distinguished from it empirically.
Thinning	Selective removal of trees to reduce stand density and competition between trees in a stand, primarily undertaken to improve the growth rate or health of the remaining trees.
Wetland	Area of land whose soil is saturated with moisture either permanently or seasonally.

⁶ According to Intergovernmental Panel on Climate Change Good Practice Guidance for Land Use, Land-Use Change and Forestry, table 3.2.1 on page 3.15



CDM Methodology Booklet

Chapter III

METHODOLOGIES FOR CDM PROJECT ACTIVITIES

3.1. INTRODUCTION TO METHODOLOGIES FOR CDM PROJECT ACTIVITIES

Methodologies provide the information that is required in order to determine the amount of Certified Emission Reductions (CERs) generated by a mitigation project activity. The following main sections can be found in a methodology:

- Definitions that are required to apply the methodology;
- Description of the applicability of the methodology;
- Description of the project boundary;
- Procedure to establish the baseline scenario;
- Procedure to demonstrate and assess additionality;
- Procedure to calculate emission reductions;
- Description of the monitoring procedure.

Further guidance to project developers is available in other CDM regulatory documents, such as standards (including methodological tools), procedures and guidelines (available through the CDM website).

Methodologies for large-scale project activities can be used for project activities of any size, whereas small-scale methodologies can only be applied if the project activity is within certain limits. Small-scale methodologies are grouped into three different types:

- *Type I:* Renewable energy project activities with a maximum output capacity of 15 MW (or an appropriate equivalent);
- *Type II:* Energy efficiency improvement project activities which reduce energy consumption, on the supply and/or demand side, with a maximum output (i.e. maximum savings) of 60 GWh per year (or an appropriate equivalent);
- *Type III:* Other project activities that result in emission reductions of less than or equal to 60 kt CO₂ equivalent per year.

More detailed information on specific limits can be found in each small-scale methodology.

3.2. METHODOLOGICAL TOOLS FOR CDM PROJECT ACTIVITIES

Methodological tools are generic modules that can be referenced in large-scale and small-scale methodologies in order to determine a specific condition (e.g. additionality of a CDM project activity) or to calculate particular emissions (e.g. emissions from electricity consumption). It is stated in the methodology if a methodology requires application of a certain methodological tool. A list and a short description of current methodological tools can be found below. These tools can be accessed from the CDM website.

Tools that apply to A/R methodologies are described in [section 4.2](#).

TOOL FOR THE DEMONSTRATION AND ASSESSMENT OF ADDITIONALITY

The tool provides a step-wise approach to demonstrate and assess the additionality of a CDM project activity. These steps are:

- Step 1* Identification of alternatives to the project activity;
- Step 2* Investment analysis;
- Step 3* Barriers analysis; and
- Step 4* Common practice analysis.

The tool is required by many methodologies.

COMBINED TOOL TO IDENTIFY THE BASELINE SCENARIO AND DEMONSTRATE ADDITIONALITY

This tool provides a step-wise approach to identify the baseline scenario and simultaneously demonstrate additionality of a CDM project activity. Similar to the “Tool for the demonstration and assessment of additionality” the procedure is based on four steps, however in a different order:

- Step 1* Identification of alternative scenarios;
- Step 2* Barrier analysis;
- Step 3* Investment analysis (if applicable);
- Step 4* Common practice analysis.

Step 4 is not required if the project activity is first-of-its-kind. The tool is required by many methodologies.

TOOL TO CALCULATE PROJECT OR LEAKAGE CO₂ EMISSIONS FROM FOSSIL FUEL COMBUSTION

This tool provides procedures to calculate project and/or leakage CO₂ emissions from the combustion of fossil fuels. It can be used in cases where CO₂ emissions from fossil fuel combustion are calculated based on the quantity of fuel combusted and its properties. This tool is required by methodologies whenever fossil fuel combustion is relevant in the project scenario or leakage.

EMISSIONS FROM SOLID WASTE DISPOSAL SITES

This tool calculates emissions of methane from waste disposed of in a solid waste disposal sites (SWDS). Emission reductions are calculated with a first order decay model. The tool is applicable to calculating baseline, project and leakage emissions and to both situations that the solid waste disposal site can or cannot be clearly identified. The tool is required by landfill methodologies (e.g. [ACM0001](#) or [AMS-III.G.](#)), alternative waste treatment methodologies (e.g. [ACM0022](#) or [AMS-III.F.](#)) and biomass methodologies (e.g. [ACM0006](#) or [AMS-III.E.](#)).

TOOL TO CALCULATE BASELINE, PROJECT AND/OR LEAKAGE EMISSIONS FROM ELECTRICITY CONSUMPTION

This tool provides procedures to estimate the baseline, project and/or leakage emissions associated with the consumption of electricity. The tool may, for example, be required by methodologies where auxiliary electricity is consumed in the project and/or the baseline scenario.

PROJECT EMISSIONS FROM FLARING

This tool provides procedures to calculate project emissions from flaring of a residual gas where methane is the component with the highest concentration in the flammable residual gas. Due to incomplete flaring of methane or even non-operation of the flare, methane emissions may occur in the project scenario. By determination of a flaring efficiency, such effects are taken into account.

TOOL TO CALCULATE THE EMISSION FACTOR FOR AN ELECTRICITY SYSTEM

This methodological tool determines the CO₂ emission factor of electricity generated by power plants in an electricity system, by calculating the “combined margin” emission factor of the electricity system. The combined margin is the result of a weighted average of two emission factors of the electricity system: the “operating margin” and the “build margin”. The operating margin is the emission factor of the thermal power plants and all plants serving the grid. The build margin is the emission factor of a group of recently built power plants. This tool is required whenever electricity consumption or generation is relevant in the baseline and/or project scenario or in terms of leakage. It is particularly relevant for grid-connected electricity generation methodologies.

TOOL TO DETERMINE THE MASS FLOW OF A GREENHOUSE GAS IN A GASEOUS STREAM

This tool provides procedures to determine the mass flow of a greenhouse gas in a gaseous stream, based on measurements of (a) the total volume or mass flow of the gas stream and (b) the volumetric fraction of the gas in the gas stream. The volume flow, mass flow and volumetric fraction may be measured on a dry basis or wet basis.

TOOL TO DETERMINE THE BASELINE EFFICIENCY OF THERMAL OR ELECTRIC ENERGY GENERATION SYSTEMS

The tool describes various procedures to determine the baseline efficiency of an energy generation system such as a power plant or an industrial boiler, for the purpose of estimating baseline emissions. The tool is used in case of project activities that improve the energy efficiency of an existing system through retrofits or replacement of the existing system by a new system. This tool provides different procedures to determine the baseline efficiency of the system: either a) a load-efficiency function is determined which establishes the efficiency as a function of the operating load of the system or b) the efficiency is determined conservatively as a constant value.

TOOL TO DETERMINE THE REMAINING LIFETIME OF EQUIPMENT

The tool provides guidance to determine the remaining lifetime of baseline or project equipment. An application of the tool would be for project activities which involve the replacement of existing equipment with new equipment or which retrofit existing equipment as part of energy efficiency improvement activities. Under this tool, impacts on the lifetime of the equipment due to policies and regulations (e.g. environmental regulations) or changes in the services needed (e.g. increased energy demand) are not considered.

ASSESSMENT OF THE VALIDITY OF THE ORIGINAL/CURRENT BASELINE AND TO UPDATE OF THE BASELINE AT THE RENEWAL OF THE CREDITING PERIOD

This tool provides a procedure to assess the continued validity of the baseline and to update it at the renewal of a crediting period. The tool consists of two steps. The first step provides an approach to evaluate whether the current baseline is still valid for the next crediting period. The second step provides an approach to update the baseline in case that the current baseline is not valid anymore for the next crediting period.

This tool is applicable in a situation where the crediting period needs to be renewed.

PROJECT AND LEAKAGE EMISSIONS FROM TRANSPORTATION OF FREIGHT

This tool provides procedures to estimate project and/or leakage CO₂ emissions from road transportation of freight by vehicles. Two options are provided to determine these emissions:

- Option A: Monitoring fuel consumption; or
- Option B: Using conservative default values.

The tool also provides default conservative emission factors to estimate project and/or leakage CO₂ emissions from freight transportation by rail.

The tool is applicable to project activities which involve transportation of freight and where transportation is not the main project activity.

PROJECT AND LEAKAGE EMISSIONS FROM COMPOSTING

This tool calculates project and leakage emissions from composting and co-composting. It accounts for methane and nitrous oxide emissions from the composting process, energy requirements to operate the composting plant, treatment of run-off wastewater and leakage emissions associated with the end-use of the compost product. Options are given in the tool to calculate emissions based on monitored parameters or conservative default values.

PROJECT AND LEAKAGE EMISSIONS FROM ANAEROBIC DIGESTERS

This methodological tool provides procedures to calculate project and leakage emissions associated with anaerobic digestion in an anaerobic digester. The tool is not applicable to other systems where waste may be decomposed anaerobically, for instances stockpiles, SWDS or un-aerated lagoons. It is particularly relevant for waste management methodologies such as [ACM0022](#).

UPSTREAM LEAKAGE EMISSIONS ASSOCIATED WITH FOSSIL FUEL USE

This methodological tool provides a procedure to calculate leakage upstream emissions associated with the use of fossil fuels. Upstream emissions associated with fossil fuel use are emissions from fugitive emissions, combustion of fossil fuel and consumption of electricity. The fossil fuels applicable to this tool are those that can be categorized to be either based on natural gas, oil or coal. The tool is applicable to fossil fuel use in either or both the baseline scenario and project activity as well as fossil fuel consumption from leakage emissions. The tool provides two options to determine emissions: Option (A) provides simple default emission factors for different types of fossil fuels; and Option (B) calculation of emission factors based on emissions for each upstream emissions stage.

PROJECT EMISSIONS FROM CULTIVATION OF BIOMASS

This tool provides a procedure to calculate project emissions from cultivation of biomass. It can be used for estimation of project emissions resulting from cultivation of biomass in a dedicated plantation of a CDM project activity that uses biomass as a source of energy. The tool is limited to types of land for which such emissions can be estimated with relative reliability, and therefore excludes wetlands and organic soils.

BASELINE EMISSIONS FOR MODAL SHIFT MEASURES IN INTER-URBAN CARGO TRANSPORT

The tool provides step-wise methodological guidance to estimate baseline emissions for transport projects implementing modal shift measures in inter-urban cargo transport:

- Step 1* Determine relevant cargo types;
- Step 2* Determine the mode share for each relevant cargo type;
- Step 3* Determine the average specific emission factor per TKM for cargo type;
 - 3.1 Rail; 3.2 Domestic water;
 - 3.3 Pipeline; 3.4 Road;
- Step 4* Determine baseline emission factor;
- Step 5* Determine baseline emissions.

The tool is applicable for estimating baseline emissions for individual CDM project activities in inter-urban cargo transport that implement a measure or a group of measures aimed at modal shift from road to water-borne (using barges or domestic ships) or rail transportation. This tool can be used by designated national authorities (DNAs) for establishing standardized baselines for these measures.

BASELINE EMISSIONS FOR MODAL SHIFT MEASURES IN URBAN PASSENGER TRANSPORT

The tool provides step-wise methodological guidance to estimate baseline emissions for transport projects implementing modal shift measures in urban passenger transport:

- Step 1* Determine relevant vehicle categories;
- Step 2* Determine the emission factor per kilometre for each relevant vehicle category;
- Step 3* Determine the emission factor per passenger-kilometre;
- Step 4* Determine baseline emissions.

The tool is applicable for estimating baseline emissions for individual CDM project activities in urban passenger transport that implement a measure or a group of measures aimed at modal shift to urban public transit such as metro, bus rapid transit, light rail and trams. This tool can be used by DNAs for establishing standardized baselines for these measures.



CDM Methodology Booklet

Chapter III

3.3. METHODOLOGIES FOR LARGE-SCALE CDM PROJECT ACTIVITIES

AM0001 Decomposition of fluoroform (HFC-23) waste streams

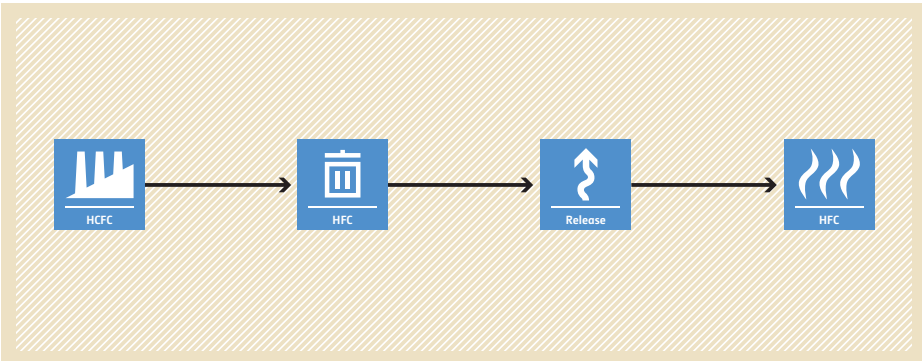
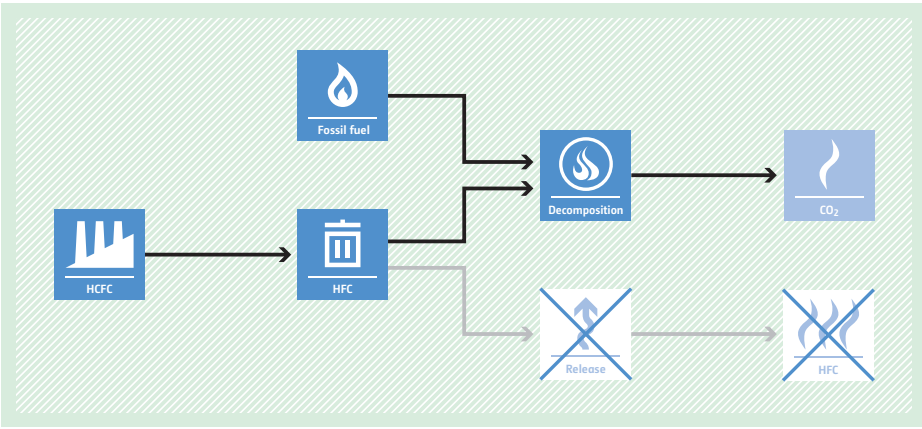
Typical project(s)	Project activities which capture and decompose HFC-23 formed in the production of HCFC-22.
Type of GHG emissions mitigation action	<ul style="list-style-type: none"> • GHG destruction Destruction of HFC-23 emissions.
Important conditions under which the methodology is applicable	<ul style="list-style-type: none"> • At least one HCFC-22 reaction unit at the project activity site has an operating history of at least three years between 1 January 2000 and 31 December 2004 and has been in operation from 2005 until the start of the project activity; • The HFC-23 decomposition and, if applicable, any temporary storage of HFC-23, occurs only at the project activity site (i.e. no off-site transport occurs); • No regulation requires the decomposition of the total amount of HFC-23 generated; • No HFC-23 decomposition facility was installed prior to implementation of the project activity.
Important parameters	At validation: <ul style="list-style-type: none"> • Average annual HCFC-22 equivalent production level in specific HCFC-22 production line in the historical three year period from 2002 to 2004. • Quantities of carbon and fluorine contained in hydrogen fluoride fed into HCFC-22 reactor units and in the HCFC-22 produced by specific production line, required for fluorine and carbon mass balance to determine the HFC-23 waste generation rate for years prior to the implementation of the project activity.
	Monitored: <ul style="list-style-type: none"> • Quantity of HFC-23 generated as a by-product in specific HCFC-22 production line in specific monitoring period; • Quantity of HFC-23 that is generated as a by-product in HCFC-22 production lines that are eligible for crediting and that is supplied to the inlet of the HFC-23 decomposition facility(ies) d in specific monitoring period.
BASELINE SCENARIO HFC-23 is released to the atmosphere from the production of HCFC-22.	 <p>The baseline scenario flowchart shows a linear process: HCFC production (factory icon) leads to HFC waste (trash can icon), which is then released (upward arrow icon) into the atmosphere as HFC emissions (flame icon).</p>
PROJECT SCENARIO HFC-23 emitted from the production of HCFC-22 is decomposed using fossil fuel in a decomposition facility, resulting into CO ₂ emissions.	 <p>The project scenario flowchart shows HCFC production (factory icon) leading to HFC waste (trash can icon). This waste is then fed into a decomposition facility (flame icon) which also receives fossil fuel (flame icon). The decomposition facility produces CO₂ emissions (flame icon) and prevents the HFC from being released (crossed-out upward arrow icon) into the atmosphere as HFC emissions (crossed-out flame icon).</p>

AM0007 Analysis of the least-cost fuel option for seasonally-operating biomass cogeneration plants

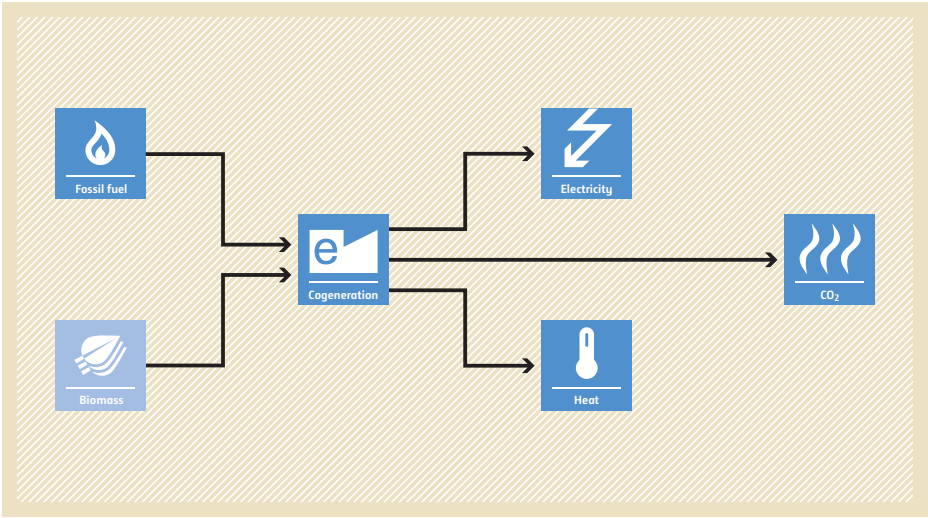
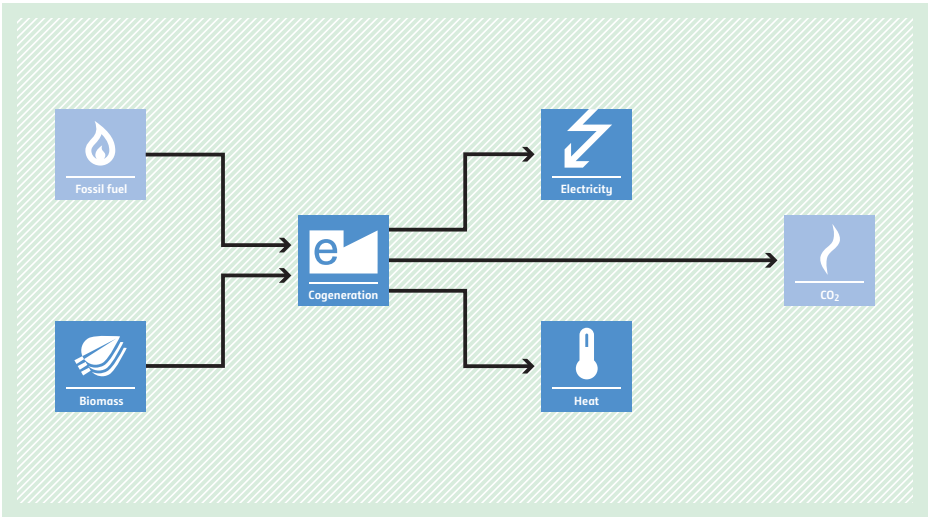
<p>Typical project(s)</p>	<p>Refurbishment and fuel switch of renewable biomass cogeneration projects connected to the grid which operate in seasonal mode and use other fuel during the off-season, when biomass – for instance bagasse in case of a sugar mill – is not being produced.</p>
<p>Type of GHG emissions mitigation action</p>	<ul style="list-style-type: none"> • Renewable Energy. Displacement of more-GHG-intensive power generation using fossil fuel.
<p>Important conditions under which the methodology is applicable</p>	<ul style="list-style-type: none"> • The proposed project has access to biomass that is not currently used for energy purposes.
<p>Important parameters</p>	<p>At validation:</p> <ul style="list-style-type: none"> • Leakage emissions due to biomass transport and crowding out of biomass for other plants; • Baseline emission factor of the cogeneration plant based on the use of the least-cost fuel available (usually fossil fuel). <hr/> <p>Monitored:</p> <ul style="list-style-type: none"> • Power generated by the project; • Quantity of biomass used in the project; • Electricity and fossil fuel consumption of the project.
<p>BASILINE SCENARIO Power would be produced with the least cost fuel (usually fossil fuels) in the absence of the project.</p>	 <p>The diagram illustrates the baseline scenario. It features a central 'Cogeneration' box with a blue 'e' icon. Two input boxes on the left, 'Fossil fuel' (flame icon) and 'Biomass' (leaf icon), have arrows pointing to the 'Cogeneration' box. From the 'Cogeneration' box, three arrows point to output boxes: 'Electricity' (lightning bolt icon), 'Heat' (thermometer icon), and 'CO2' (flame icon). The entire diagram is set against a light brown background with a diagonal line pattern.</p>
<p>PROJECT SCENARIO Use of renewable biomass for power generation avoids the use of fossil fuel.</p>	 <p>The diagram illustrates the project scenario. It features a central 'Cogeneration' box with a blue 'e' icon. Only one input box on the left, 'Biomass' (leaf icon), has an arrow pointing to the 'Cogeneration' box. The 'Fossil fuel' input box is present but has no arrow. From the 'Cogeneration' box, three arrows point to output boxes: 'Electricity' (lightning bolt icon), 'Heat' (thermometer icon), and 'CO2' (flame icon). The entire diagram is set against a light green background with a diagonal line pattern.</p>

AM0009 Recovery and utilization of gas from oil fields that would otherwise be flared or vented

<p>Typical project(s)</p>	<p>Associated gas from oil fields (including gas-lift gas) that was previously flared or vented is recovered and utilized.</p>
<p>Type of GHG emissions mitigation action</p>	<ul style="list-style-type: none"> Fuel switch. <p>Displacement of use of other fossil fuel sources such as natural gas, dry gas, LPG, condensate etc. coming from non-associated gas by utilizing associated gas and/or gas-lift gas from oil fields.</p>
<p>Important conditions under which the methodology is applicable</p>	<ul style="list-style-type: none"> The recovered gas comes from oil wells that are in operation and are producing oil at the time of the recovery; The recovered gas is transported to a gas pipeline with or without prior processing. Prior processing may include transportation to a processing plant where the recovered gas is processed into hydrocarbon products (e.g. dry gas, liquefied petroleum gas (LPG)). The dry natural gas is either: (i) transported to a gas pipeline directly; or (ii) compressed to CNG first, then transported by trailers/trucks/carriers and then decompressed again.
<p>Important parameters</p>	<p>Monitored:</p> <ul style="list-style-type: none"> Quantity and net calorific value of the total recovered gas measured after pre-treatment and after the point where the recovered gas is directed for on-site use.
<p>BASELINE SCENARIO Associated gas from oil wells is flared or vented and non-associated gas is extracted from other gas wells.</p>	
<p>PROJECT SCENARIO Associated gas from oil wells is recovered and utilized and non-associated gas is not extracted from other gas wells.</p>	

AM0014 Natural gas-based package cogeneration

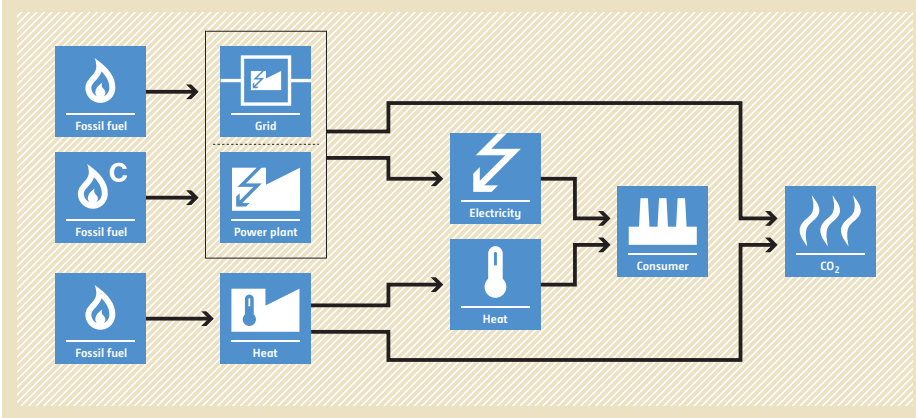
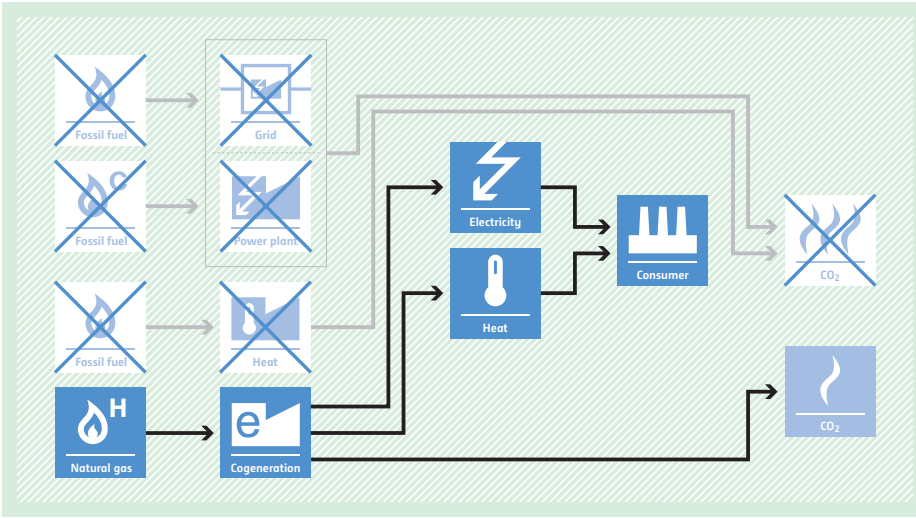
<p>Typical project(s)</p>	<p>Construction and operation of a natural-gas-fired cogeneration plant that supplies electricity and heat to an existing consuming facility.</p>
<p>Type of GHG emissions mitigation action</p>	<ul style="list-style-type: none"> • Energy efficiency. • Fuel savings through energy efficiency improvement. Optional use of a less-carbon-intensive fuel.
<p>Important conditions under which the methodology is applicable</p>	<ul style="list-style-type: none"> • The electricity and heat requirement of the facility that the project cogeneration plant supplies to (consuming facility) would be generated in separate systems in the absence of the project; • No surplus electricity from the cogeneration plant is supplied to the grid; • No surplus heat from the cogeneration plant is provided to users different from the consuming facility.
<p>Important parameters</p>	<p>At validation:</p> <ul style="list-style-type: none"> • Fuel consumption for heat supply by the existing heat-only generation units; • Electricity generation by the grid or the existing power-only generation units; • Emission factor of the grid or the existing power-only generation units. <p>Monitored:</p> <ul style="list-style-type: none"> • Natural gas consumption by the project cogeneration plant; • Electricity supplied by the project cogeneration plant to the consuming facility; • Heat supplied by the project cogeneration plant to the consuming facility.
<p>BASELINE SCENARIO The electricity demand of a facility is meeting via either power-only generation units, or the grid and heat from heat-only generation units.</p>	 <p>The diagram illustrates the baseline scenario. On the left, three boxes labeled 'Fossil fuel' with icons of a flame, a flame with a 'C', and a flame with a heat symbol, have arrows pointing to three boxes: 'Grid' (with a plug icon), 'Power plant' (with a lightning bolt icon), and 'Heat' (with a heat symbol icon). From the 'Grid' and 'Power plant' boxes, arrows point to a box labeled 'Electricity' (with a lightning bolt icon). From the 'Heat' box, an arrow points to a box labeled 'Heat' (with a heat symbol icon). Both the 'Electricity' and 'Heat' boxes have arrows pointing to a box labeled 'Consumer' (with a factory icon). From the 'Consumer' box, an arrow points to a box labeled 'CO₂' (with a flame icon).</p>
<p>PROJECT SCENARIO The consuming facility is supplied electricity and heat from a natural-gas-fired cogeneration plant.</p>	 <p>The diagram illustrates the project scenario. On the left, three boxes labeled 'Fossil fuel' with icons of a flame, a flame with a 'C', and a flame with a heat symbol are crossed out with a large 'X'. Below them is a box labeled 'Natural gas' with a flame icon and a letter 'H'. An arrow from 'Natural gas' points to a box labeled 'Cogeneration' with a lightning bolt icon and a letter 'e'. From the 'Cogeneration' box, two arrows point to boxes labeled 'Electricity' (with a lightning bolt icon) and 'Heat' (with a heat symbol icon). Both the 'Electricity' and 'Heat' boxes have arrows pointing to a box labeled 'Consumer' (with a factory icon). From the 'Consumer' box, an arrow points to a box labeled 'CO₂' (with a flame icon). Additionally, three boxes labeled 'Grid', 'Power plant', and 'Heat' are also crossed out with a large 'X'.</p>

AM0017 Steam system efficiency improvements by replacing steam traps and returning condensate

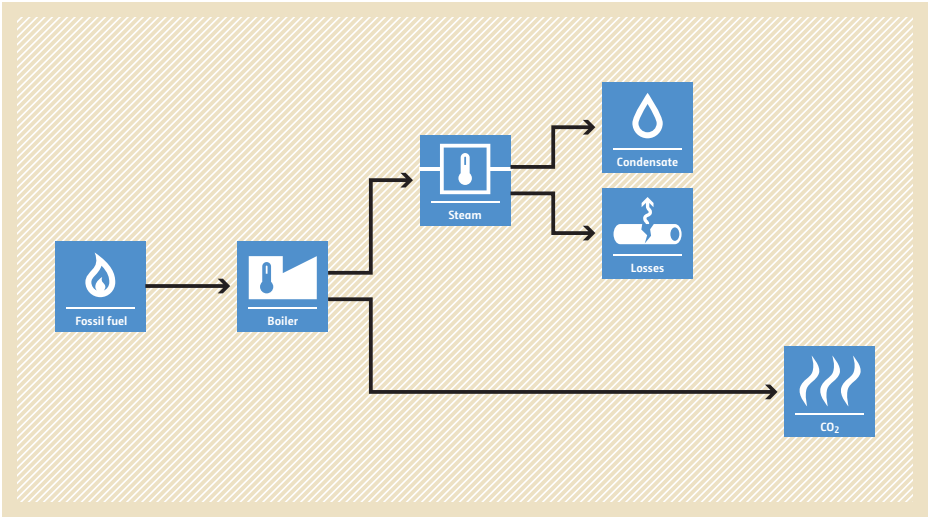
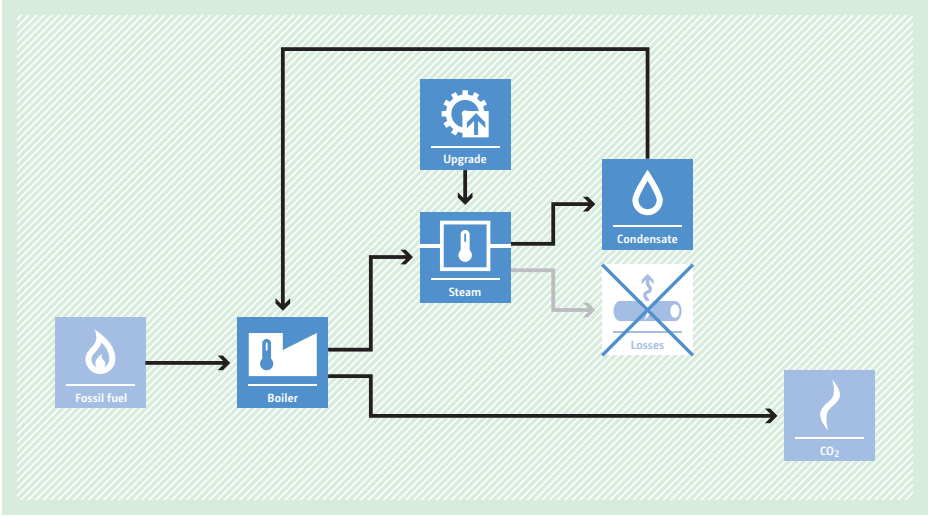
<p>Typical project(s)</p>	<p>Optimization of steam distribution, end-use and condensate return to increase the energy efficiency of a steam system.</p>
<p>Type of GHG emissions mitigation action</p>	<ul style="list-style-type: none"> • Energy efficiency. <p>Reduction of fossil fuel use and corresponding emissions through energy efficiency improvements.</p>
<p>Important conditions under which the methodology is applicable</p>	<ul style="list-style-type: none"> • Steam is generated in a boiler fired with fossil fuel; • The regular maintenance of steam traps or the return of condensate is not common practice or required under regulations in the respective country; • Data on the condition of steam traps and the return of condensate is accessible in at least five other similar plants.
<p>Important parameters</p>	<p>At validation:</p> <ul style="list-style-type: none"> • Steam trap failure rate and condensate return at plant and other similar plants. <p>Monitored:</p> <ul style="list-style-type: none"> • Steam and condensate flow, temperature and pressure; • Boiler efficiency; • Electricity consumption of the project.
<p>BASELINE SCENARIO Use of fossil fuel in a boiler to supply steam to a steam system with a low efficiency.</p>	 <p>The diagram illustrates the baseline scenario. It shows a flow from 'Fossil fuel' to a 'Boiler'. The boiler produces 'Steam', which is then used for a process. From this process, 'Condensate' is produced but is lost to the atmosphere, represented by a 'Losses' icon. This leads to a higher amount of 'CO2' emissions compared to the project scenario.</p>
<p>PROJECT SCENARIO Use of less fossil fuel in a boiler as less steam is required for the steam system with improved efficiency.</p>	 <p>The diagram illustrates the project scenario. It shows a flow from 'Fossil fuel' to a 'Boiler'. The boiler produces 'Steam', which is used for a process. The 'Condensate' is captured and returned to the boiler through an 'Upgrade' (replacing steam traps). This results in reduced 'Losses' and a lower amount of 'CO2' emissions compared to the baseline scenario.</p>

AM0018 Baseline methodology for steam optimization systems

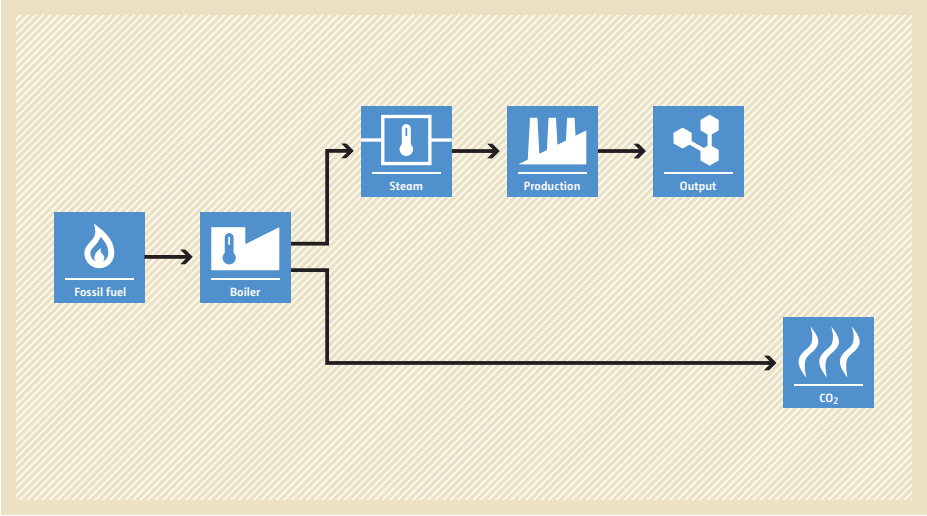
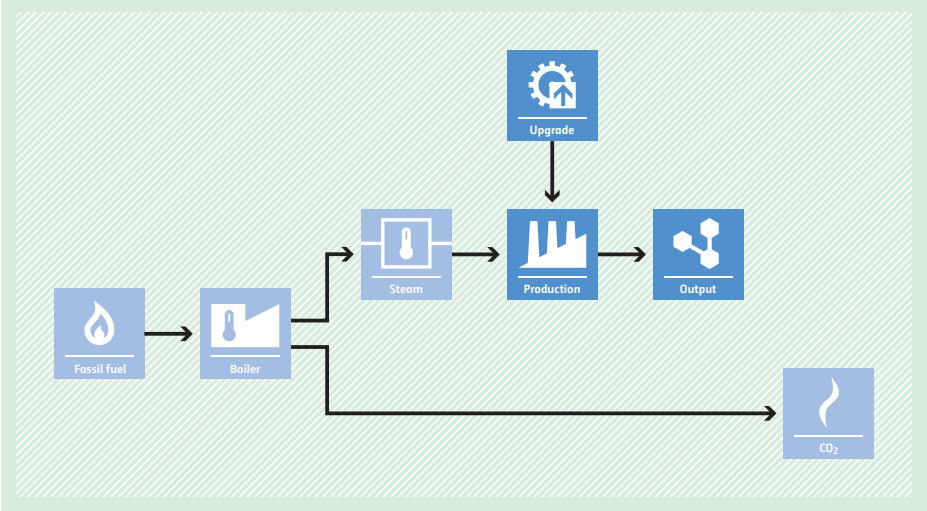
<p>Typical project(s)</p>	<p>More-efficient use of steam in a production process reduces steam consumption and thereby steam generation.</p>
<p>Type of GHG emissions mitigation action</p>	<ul style="list-style-type: none"> • Energy efficiency. <p>Reduction of fossil fuel use and corresponding emissions through energy efficiency improvements.</p>
<p>Important conditions under which the methodology is applicable</p>	<ul style="list-style-type: none"> • The process supplied by the heat system produces a homogeneous output and its production volume is reasonably constant under steady state conditions; • For cogeneration systems, steam generation at boiler decreases by the amount of steam saved; • If the steam saved is further used, it shall be demonstrated it does not increase GHG emissions.
<p>Important parameters</p>	<p>Monitored:</p> <ul style="list-style-type: none"> • Output of the main process involved in the project; • Steam, feed water, blow down water flow, temperature and pressure; • Boiler efficiency.
<p>BASELINE SCENARIO Use of fossil fuel in a boiler to supply steam to a process with high steam consumption.</p>	 <p>The diagram illustrates the baseline scenario. It starts with a 'Fossil fuel' icon (flame) pointing to a 'Boiler' icon (thermometer). From the boiler, an arrow points to a 'Steam' icon (thermometer), which then points to a 'Production' icon (factory). The 'Production' icon points to an 'Output' icon (molecules). A separate arrow from the boiler points to a 'CO₂' icon (flames).</p>
<p>PROJECT SCENARIO Use of less fossil fuel in a boiler as less steam is required for the process with a higher efficiency.</p>	 <p>The diagram illustrates the project scenario. It follows the same flow as the baseline: 'Fossil fuel' to 'Boiler', 'Boiler' to 'Steam', 'Steam' to 'Production', and 'Production' to 'Output'. However, an 'Upgrade' icon (gears) points to the 'Production' process, indicating an efficiency improvement. Additionally, the 'CO₂' emissions box is smaller than in the baseline scenario, indicating reduced emissions.</p>

AM0019 Renewable energy projects replacing part of the electricity production of one single fossil fuel fired power plant that stands alone or supplies to a grid, excluding biomass projects

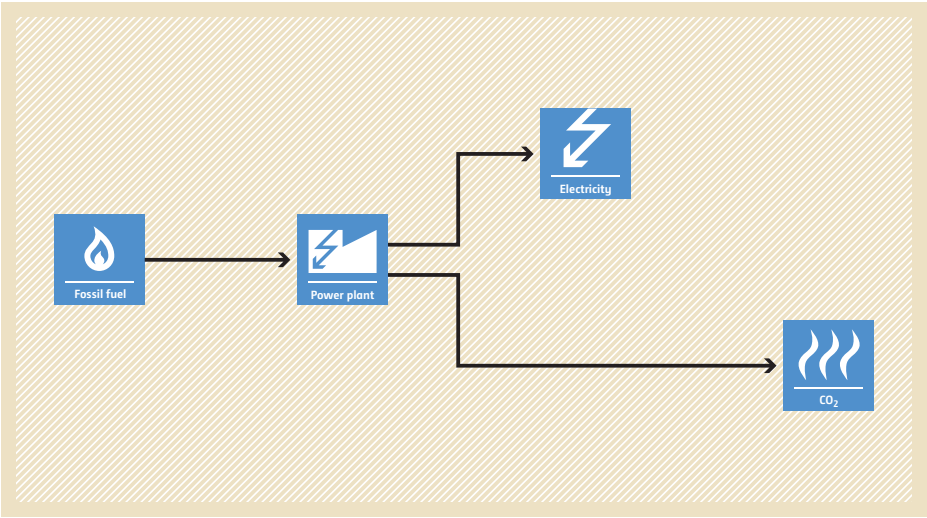
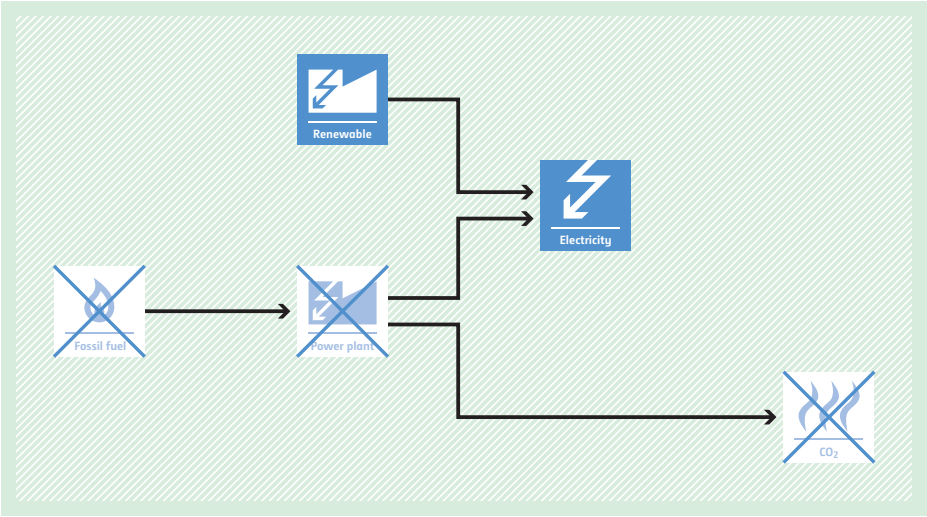
<p>Typical project(s)</p>	<p>Generation of electricity from the zero-emission renewable energy sources such as wind, geothermal, solar, hydro, wave and/or tidal projects that displaces electricity produced from a specific fossil fuel plant.</p>
<p>Type of GHG emissions mitigation action</p>	<ul style="list-style-type: none"> • Renewable energy. <p>Displacement of more-GHG-intensive generation of electricity by the use of renewable energy sources.</p>
<p>Important conditions under which the methodology is applicable</p>	<ul style="list-style-type: none"> • Biomass projects are not eligible; • The identified baseline plant is able to meet any possible increase of energy demand that occurs during the crediting period; • Three years of historical data is required for the calculation of emissions reductions; • Hydro power plants with reservoir require power densities greater than 4W/m².
<p>Important parameters</p>	<p>At validation:</p> <ul style="list-style-type: none"> • Carbon emission factor of the baseline power plant <p>Monitored:</p> <ul style="list-style-type: none"> • Quantity of electricity supplied to the grid by the project; • If the project involves geothermal energy: fugitive CO₂ and CH₄ emissions due to release of non-condensable gases from the produced steam.
<p>BASELINE SCENARIO A specific fossil fuel plant generates electricity that is supplied to the grid.</p>	 <p>The diagram shows a flow from 'Fossil fuel' (represented by a flame icon) to a 'Power plant' (represented by a lightning bolt icon). From the 'Power plant', two arrows branch out: one points to 'Electricity' (lightning bolt icon) and the other points to 'CO₂' (flame icon).</p>
<p>PROJECT SCENARIO A renewable energy plant partially or completely displaces the electricity that is generated by the specific fossil fuel power plant.</p>	 <p>The diagram shows a flow from 'Renewable' (lightning bolt icon) and a crossed-out 'Fossil fuel' (flame icon with a blue 'X') to a crossed-out 'Power plant' (lightning bolt icon with a blue 'X'). From the 'Power plant', two arrows branch out: one points to 'Electricity' (lightning bolt icon) and the other points to a crossed-out 'CO₂' (flame icon with a blue 'X').</p>

AM0020 Baseline methodology for water pumping efficiency improvements

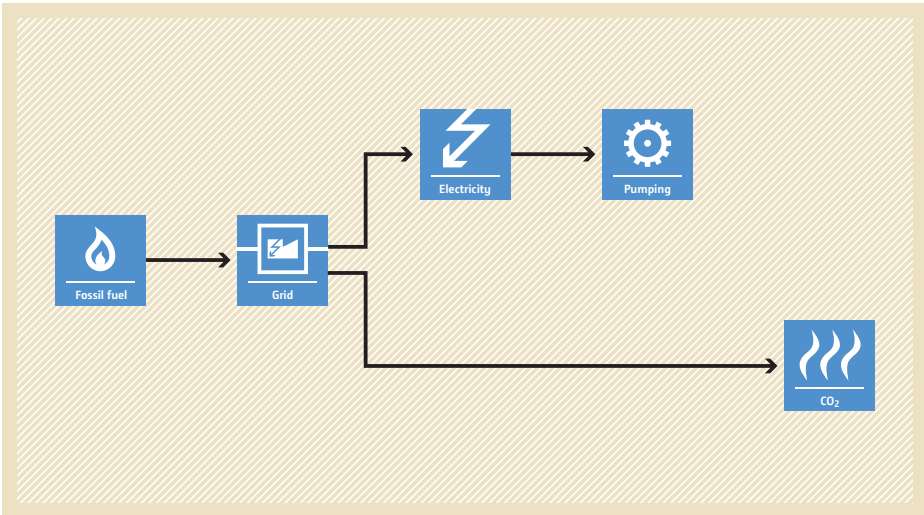
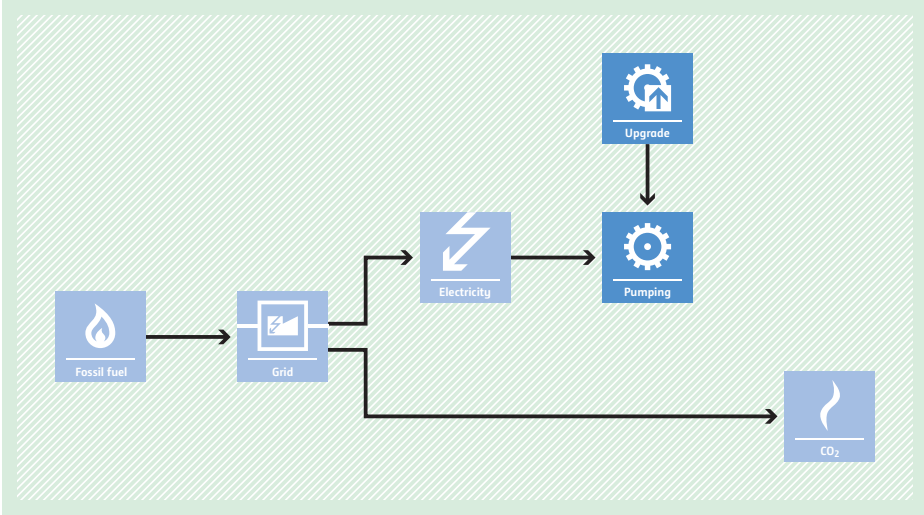
<p>Typical project(s)</p>	<p>Grid electricity savings by increasing the energy efficiency of a water pumping system through measures including reduction in technical losses, reduction in leaks and improvement in the energy efficiency of the pumping system/s (or scheme/s).</p>
<p>Type of GHG emissions mitigation action</p>	<ul style="list-style-type: none"> • Energy efficiency. <p>Switch to more energy-efficient technology.</p>
<p>Important conditions under which the methodology is applicable</p>	<ul style="list-style-type: none"> • The project pumping system is powered by grid electricity; • No performance related contract or policies in place that would trigger improvements; • New system/s developed to completely replace the old pumping system/s that will no longer be used, however the methodology applies to new system/s only up to the measured delivery capacity of the old system/s; • This methodology is not applicable to projects where entirely new system/s is/are implemented to augment the existing capacity.
<p>Important parameters</p>	<p>At validation:</p> <ul style="list-style-type: none"> • Water supplied and power consumption in the baseline situation. <hr/> <p>Monitored:</p> <ul style="list-style-type: none"> • Grid emission factor; • Water volume supplied by the project; • Electrical energy required to deliver water within the boundaries of the system.
<p>BASELINE SCENARIO Delivery of water from an inefficient pumping system.</p>	 <p>The diagram illustrates the baseline scenario. It starts with 'Fossil fuel' (represented by a flame icon) which is converted into 'Grid' electricity (represented by a plug icon). From the 'Grid', the flow splits into two paths: one goes to 'Electricity' (represented by a lightning bolt icon) and the other goes directly to 'CO₂' emissions (represented by a flame icon). The 'Electricity' path then leads to 'Pumping' (represented by a gear icon), which also leads to 'CO₂' emissions.</p>
<p>PROJECT SCENARIO Delivery of water from a pumping system that has a lower energy demand due to reducing losses or leaks in the pumping system and/or by implementing measures to increase energy efficiency.</p>	 <p>The diagram illustrates the project scenario. It follows the same initial steps as the baseline: 'Fossil fuel' is converted to 'Grid' electricity, which then powers 'Electricity' and 'Pumping'. However, an 'Upgrade' step (represented by a gear with an upward arrow icon) is added to the 'Pumping' process. This upgrade leads to a reduction in 'CO₂' emissions compared to the baseline scenario.</p>

AM0021 Baseline methodology for decomposition of N₂O from existing adipic acid production plants

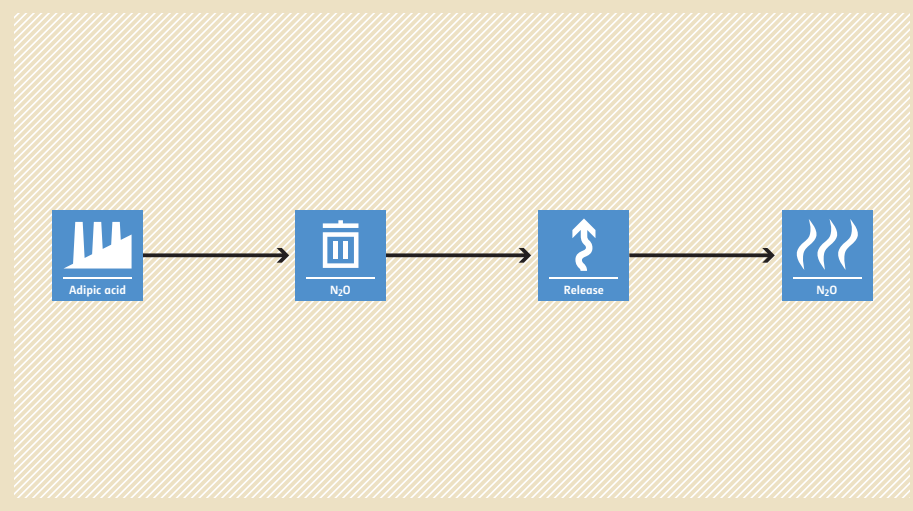
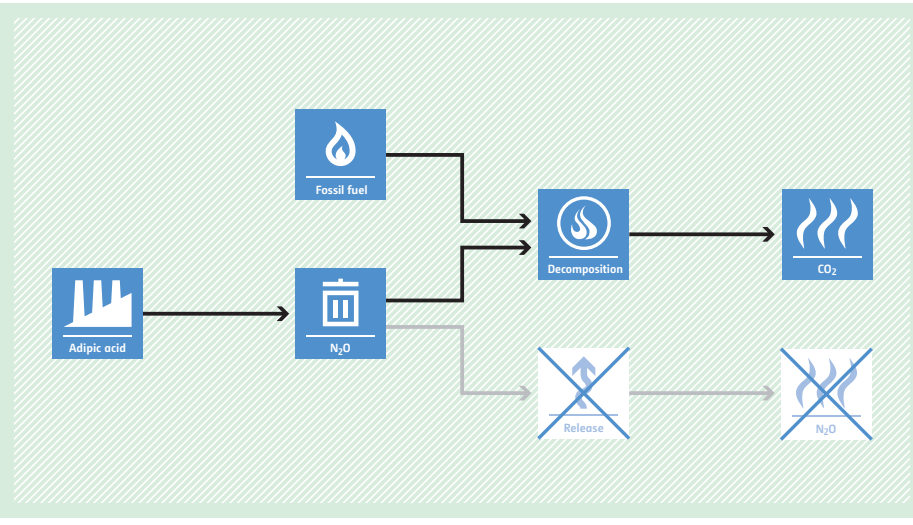
Typical project(s)	Installation of a catalytic or thermal N ₂ O destruction facility at an existing adipic acid production plant.
Type of GHG emissions mitigation action	<ul style="list-style-type: none"> • GHG destruction. • Catalytic or thermal destruction of N₂O emissions.
Important conditions under which the methodology is applicable	<ul style="list-style-type: none"> • The adipic acid plant started the commercial production no later than December 31, 2004; • European Norm 14181 must be followed for real-time measurement of N₂O concentration and gas volume flow rate.
Important parameters	At validation: <ul style="list-style-type: none"> • Maximum amount of adipic acid production in the most recent three years. <hr/> Monitored: <ul style="list-style-type: none"> • Production of adipic acid; • Consumption of nitric acid; • N₂O concentration at the inlet and outlet of the destruction facility; • Volume of gas flow at the inlet and outlet of the destruction facility.
BASILINE SCENARIO N ₂ O is emitted into the atmosphere during the production of adipic acid.	 <p>The diagram illustrates the baseline scenario. It starts with an 'Adipic acid' icon (a factory) on the left. An arrow points to an 'N₂O' icon (a trash can), representing the production of nitrous oxide. Another arrow points to a 'Release' icon (a cloud with an upward arrow), indicating the emission of N₂O. A final arrow points to an 'N₂O' icon (flames), representing the gas being released into the atmosphere.</p>
PROJECT SCENARIO N ₂ O is destroyed in a catalytic or thermal destruction unit.	 <p>The diagram illustrates the project scenario. It starts with an 'Adipic acid' icon (a factory) on the left. An arrow points to an 'N₂O' icon (a trash can). From this point, two paths emerge. The top path goes to a 'Decomposition' icon (a flame), which then leads to a 'CO₂' icon (flames), representing the destruction of N₂O into carbon dioxide. The bottom path goes to a 'Release' icon (a cloud with an upward arrow) that has a large 'X' over it, indicating that N₂O is not released. This path also leads to an 'N₂O' icon (flames) with a large 'X' over it, indicating that N₂O is not emitted. Additionally, a 'Fossil fuel' icon (a flame) has an arrow pointing to the 'Decomposition' unit, showing that fossil fuels are used in the destruction process.</p>

AM0023 Leak detection and repair in gas production, processing, transmission, storage and distribution systems and in refinery facilities

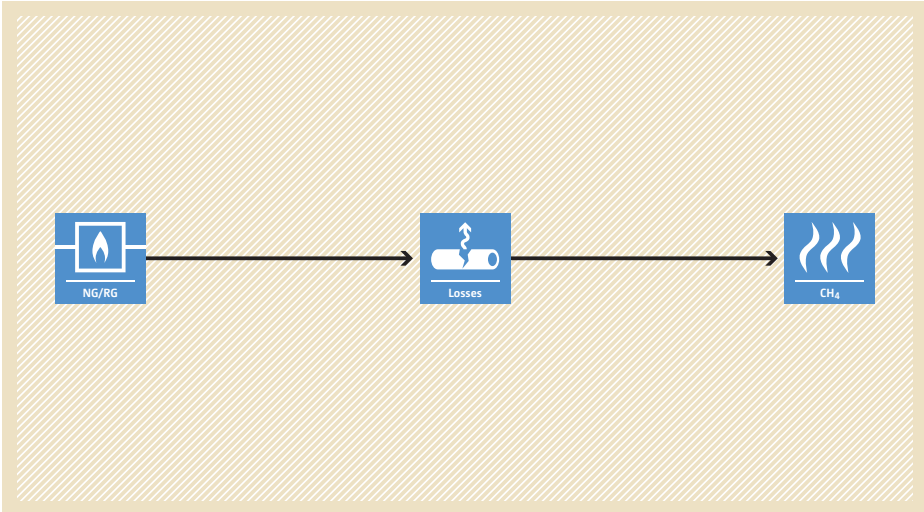
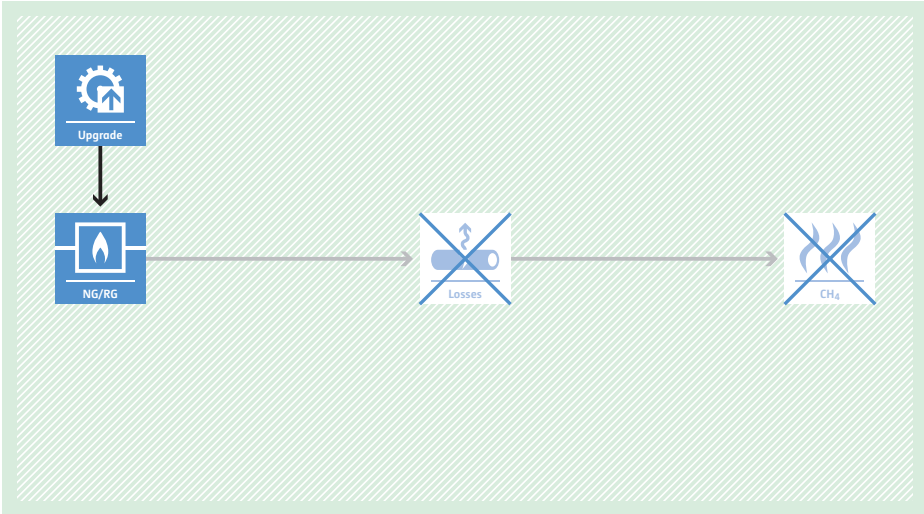
<p>Typical project(s)</p>	<p>Identification and repair of natural gas (NG) and refinery gas (RG) leaks in above-ground process equipment in natural gas production, processing, transmission, storage, distribution systems and in refinery facilities.</p>
<p>Type of GHG emissions mitigation action</p>	<ul style="list-style-type: none"> • GHG formation avoidance. • Avoidance of CH₄ emissions.
<p>Important conditions under which the methodology is applicable</p>	<ul style="list-style-type: none"> • No systems are in place to systematically identify and repair leaks in the transmission and distribution system; • Leaks can be identified and accurately measured; • A monitoring system ensures the permanence of the repairs.
<p>Important parameters</p>	<p>Monitored:</p> <ul style="list-style-type: none"> • Leak flow; • Methane concentration in the flow.
<p>BASELINE SCENARIO CH₄ leaks from a natural gas transmission distribution system.</p>	 <p>The diagram illustrates the baseline scenario. It features a horizontal flow from left to right. On the left, a blue square icon with a flame and the text 'NG/RG' represents the gas source. An arrow points to a central blue square icon showing a pipe with a leak and the text 'Losses'. A second arrow points to a rightmost blue square icon with three wavy lines and the text 'CH₄', representing methane emissions. The entire diagram is set against a light brown background with a diagonal hatching pattern.</p>
<p>PROJECT SCENARIO CH₄ leaks from the natural gas transmission systems have been repaired.</p>	 <p>The diagram illustrates the project scenario. It features a horizontal flow from left to right. At the top left, a blue square icon with a gear and an upward arrow and the text 'Upgrade' has a downward arrow pointing to a blue square icon with a flame and the text 'NG/RG'. An arrow points from 'NG/RG' to a central blue square icon showing a pipe with a leak and the text 'Losses', which is crossed out with a large blue 'X'. A second arrow points to a rightmost blue square icon with three wavy lines and the text 'CH₄', which is also crossed out with a large blue 'X'. The entire diagram is set against a light green background with a diagonal hatching pattern.</p>

AM0026 Methodology for zero-emissions grid-connected electricity generation from renewable sources in Chile or in countries with merit order based dispatch grid

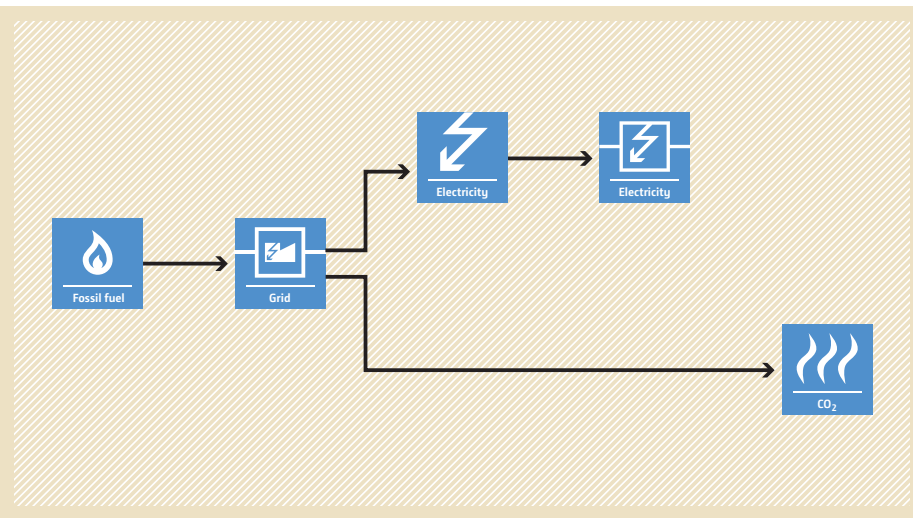
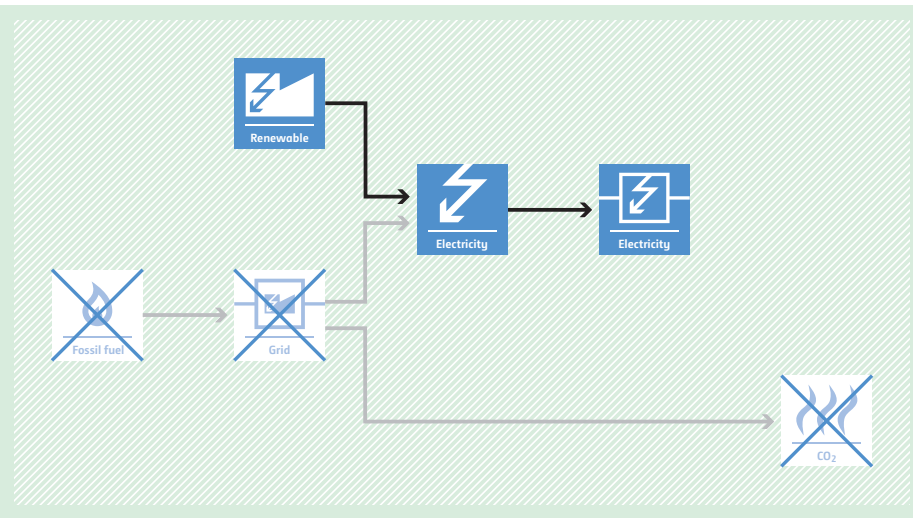
<p>Typical project(s)</p>	<p>Electricity capacity additions (either through the installation of new, or the modification of existing, power plants) that supply electricity to the grid and use renewable energy sources such as hydro, wind, solar, geothermal, wave or tidal power. The capacity additions have to be connected to the Chilean interconnected grid or others countries' grids providing a similar merit order based framework.</p>
<p>Type of GHG emissions mitigation action</p>	<ul style="list-style-type: none"> • Renewable energy. <p>Displacement of electricity that would be provided to the grid by more-GHG-intensive means.</p>
<p>Important conditions under which the methodology is applicable</p>	<ul style="list-style-type: none"> • The project power plant must either be connected to the grid of Chile and fulfil the legal obligations under the Chilean Electricity Regulation, or be implemented in other countries if the country has a regulatory framework for electricity generation and dispatch that meets the conditions described in the methodology; • New hydroelectric power projects with reservoirs require power densities greater than 4 W/m².
<p>Important parameters</p>	<p>Monitored:</p> <ul style="list-style-type: none"> • Electricity supplied to the grid by the project; • Hourly data for merit order based on marginal costs; • Operational data of the power plants connected to the same grid as the project.
<p>BASELINE SCENARIO Power is provided to the grid using more-GHG-intensive power sources.</p>	 <p>The diagram illustrates the baseline scenario. On the left, a 'Fossil fuel' icon (flame) is connected by an arrow to a 'Grid' icon (power lines). From the 'Grid', two arrows branch out: one goes to an 'Electricity' icon (lightning bolt) and another goes to a 'CO₂' icon (flames). The 'Electricity' icon is further connected to another 'Electricity' icon, representing end-users. The entire process is set against a light brown background.</p>
<p>PROJECT SCENARIO Installation of a new, or modification of an existing, renewable power plant that results in an increase of renewable power and displacement of electricity that would be provided to the grid by more-GHG-intensive means.</p>	 <p>The diagram illustrates the project scenario. On the left, a 'Renewable' icon (lightning bolt) is connected by an arrow to a 'Grid' icon (power lines). From the 'Grid', two arrows branch out: one goes to an 'Electricity' icon (lightning bolt) and another goes to a 'CO₂' icon (flames). The 'Electricity' icon is further connected to another 'Electricity' icon, representing end-users. The 'Fossil fuel' and 'CO₂' icons from the baseline scenario are shown with a large 'X' over them, indicating they are displaced. The entire process is set against a light green background.</p>

AM0027 Substitution of CO₂ from fossil or mineral origin by CO₂ from renewable sources in the production of inorganic compounds

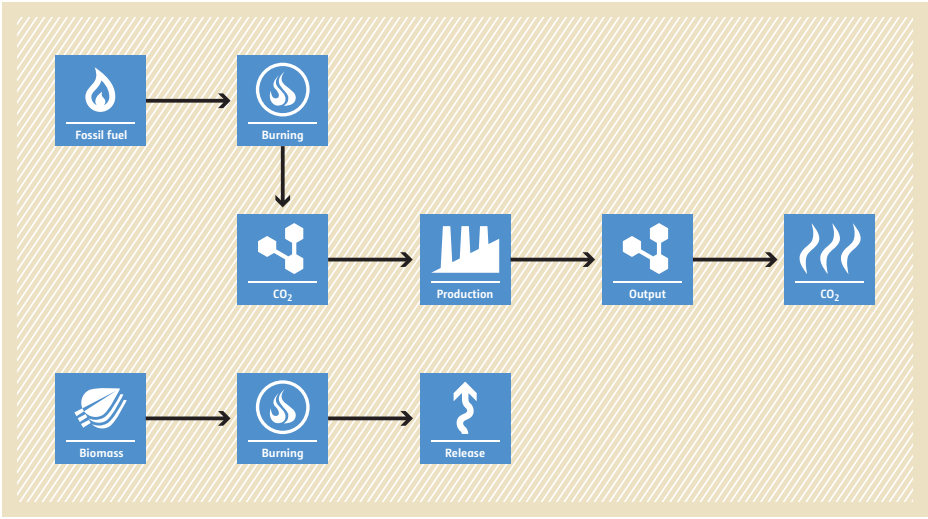
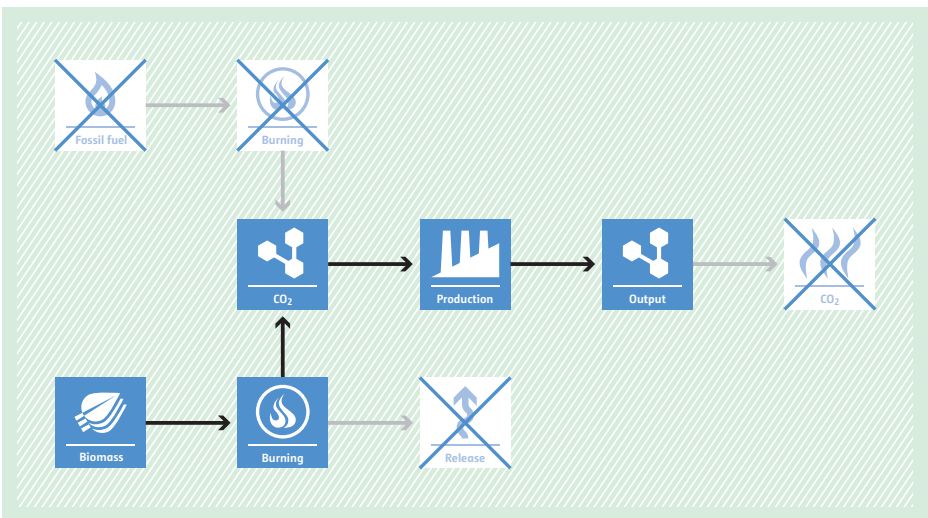
<p>Typical project(s)</p>	<p>Biomass is used as a renewable source of CO₂ for the manufacturing of inorganic compounds instead of mineral or fossil CO₂.</p>
<p>Type of GHG emissions mitigation action</p>	<ul style="list-style-type: none"> • Feedstock switch. <p>Switch from CO₂ of fossil or mineral origin to CO₂ from renewable sources.</p>
<p>Important conditions under which the methodology is applicable</p>	<ul style="list-style-type: none"> • The CO₂ from the renewable source was already produced and is not diverted from another application; • CO₂ from fossil or mineral sources used for the production of inorganic compounds in the baseline is from a production process whose only useful output is CO₂ and will not be emitted to the atmosphere in the project scenario. The CO₂ production process from fossil source does not produce any energy by-product; • No additional significant energy quantities are required to prepare the renewable CO₂ for use in the project.
<p>Important parameters</p>	<p>Monitored:</p> <ul style="list-style-type: none"> • Amount of inorganic compound produced; • Carbon content and molecular weight of the inorganic compound; • Amounts of non-renewable and renewable CO₂ used for the production of inorganic compounds.
<p>BASELINE SCENARIO Fossil or mineral sources are the source of CO₂ for the production of inorganic compounds.</p>	 <p>The diagram illustrates the baseline scenario. It shows two parallel processes. The top process starts with 'Fossil fuel' (flame icon), which goes to 'Burning' (flame icon), then to 'CO₂' (molecule icon), then to 'Production' (factory icon), then to 'Output' (molecule icon), and finally to 'CO₂' (flame icon). The bottom process starts with 'Biomass' (leaf icon), which goes to 'Burning' (flame icon), and then to 'Release' (upward arrow icon).</p>
<p>PROJECT SCENARIO Renewable sources of CO₂ are the source of CO₂ for the production of inorganic compounds.</p>	 <p>The diagram illustrates the project scenario. It shows two parallel processes. The top process starts with 'Fossil fuel' (flame icon with a blue X), which goes to 'Burning' (flame icon with a blue X), then to 'CO₂' (molecule icon), then to 'Production' (factory icon), then to 'Output' (molecule icon), and finally to 'CO₂' (flame icon with a blue X). The bottom process starts with 'Biomass' (leaf icon), which goes to 'Burning' (flame icon), and then to 'Release' (upward arrow icon with a blue X).</p>

AM0028 N₂O destruction in the tail gas of caprolactam production plants

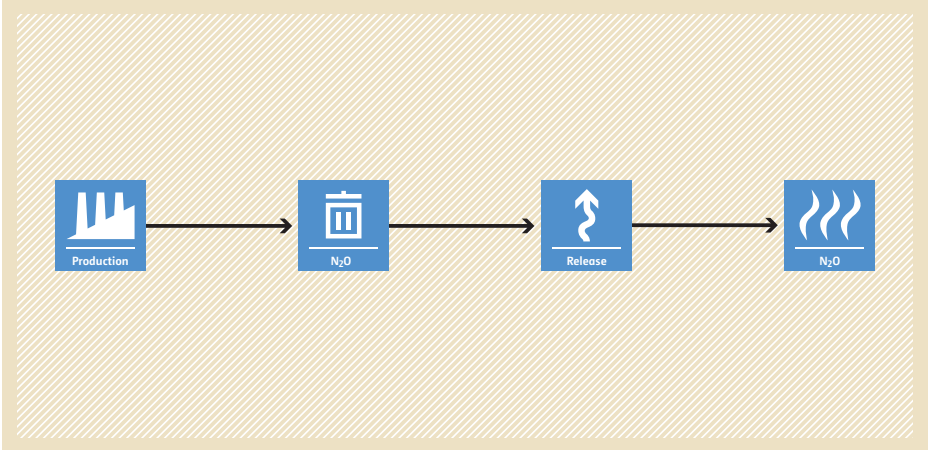
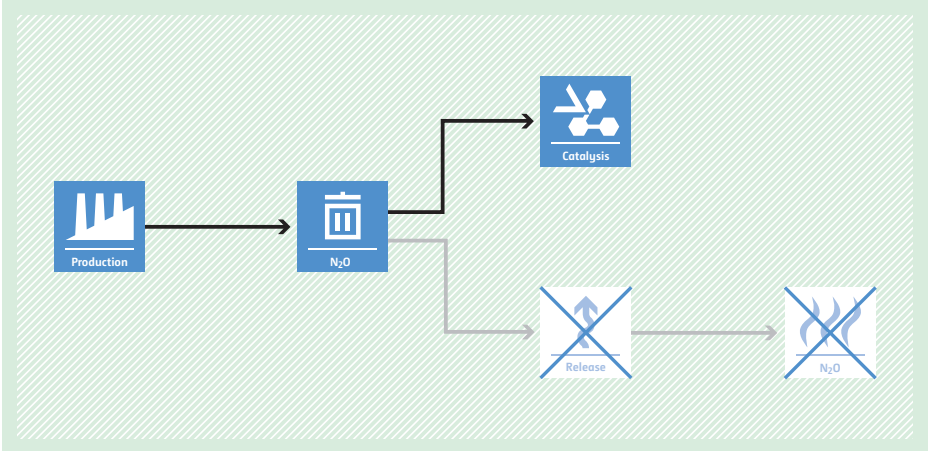
<p>Typical project(s)</p>	<p>Installation of a catalytic reduction unit to destroy N₂O emissions in the tail gas of caprolactam production plants.</p>
<p>Type of GHG emissions mitigation action</p>	<ul style="list-style-type: none"> • GHG destruction. <p>Catalytic destruction of N₂O emissions.</p>
<p>Important conditions under which the methodology is applicable</p>	<ul style="list-style-type: none"> • The caprolactam plant started the commercial production no later than December 31, 2005; • Caprolactam plants are limited to those employing the Raschig or HPO® processes; • European Norm 14181 or an equivalent standard must be followed for real-time measurement of N₂O concentration and gas volume flow rate; • The methodology allows thermal and catalytic destruction of N₂O.
<p>Important parameters</p>	<p>At validation:</p> <ul style="list-style-type: none"> • Normal operating conditions of the plant (oxidation temperature and pressure, ammonia gas flow rate to AOR, and composition of ammonia oxidation catalyst). <p>Monitored:</p> <ul style="list-style-type: none"> • Production of caprolactam; • Volume of gas flow at the inlet and outlet of the destruction facility; • N₂O concentration at the inlet and outlet of the destruction facility; • Update of the parameters for determining the normal operating conditions of the plant.
<p>BASELINE SCENARIO N₂O is emitted into the atmosphere during the production of caprolactam.</p>	 <p>The baseline scenario flowchart shows a linear process: a 'Production' icon (factory) leads to an 'N₂O' icon (gas cylinder), which leads to a 'Release' icon (upward arrow), which finally leads to an 'N₂O' icon (flames).</p>
<p>PROJECT SCENARIO N₂O is destroyed in a catalytic destruction unit installed at the tail gas stream.</p>	 <p>The project scenario flowchart shows a linear process: a 'Production' icon (factory) leads to an 'N₂O' icon (gas cylinder). From this 'N₂O' icon, the path splits: one arrow goes up to a 'Catalysis' icon (catalytic converter), and another arrow goes down to a 'Release' icon (upward arrow). From the 'Release' icon, an arrow goes to an 'N₂O' icon (flames). In the project scenario, the 'Release' and 'N₂O' icons are crossed out with a large 'X', indicating that the release and subsequent emission are prevented.</p>

AM0029 Baseline methodology for grid connected electricity generation plants using natural gas

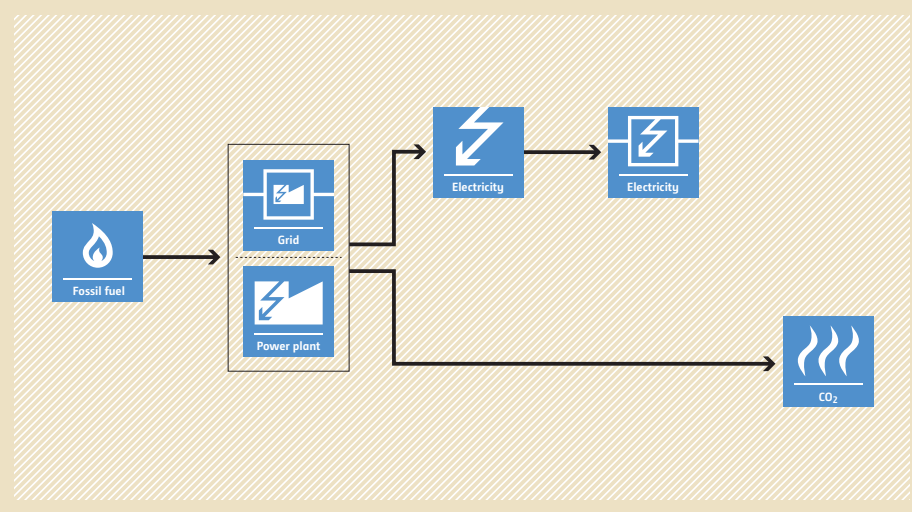
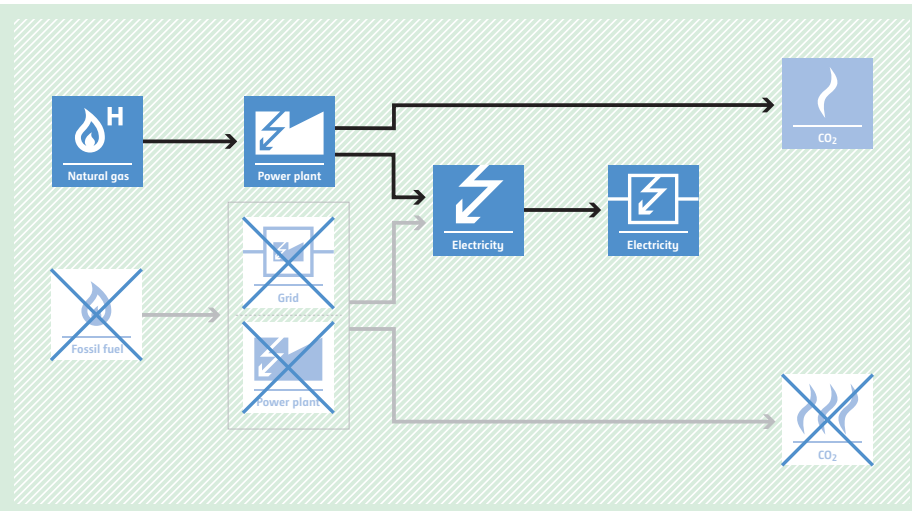
Typical project(s)	<p>The construction and operation of a new natural-gas-fired power plant that supplies electricity to the grid.</p>
Type of GHG emissions mitigation action	<ul style="list-style-type: none"> • Low carbon electricity. <p>Displacement of electricity that would be provided by more-carbon-intensive means.</p>
Important conditions under which the methodology is applicable	<ul style="list-style-type: none"> • Natural gas is sufficiently available in the region or country; • Electricity generated by the project is exclusively supplied to a power grid.
Important parameters	<p>At validation:</p> <ul style="list-style-type: none"> • Emission factor of baseline electricity generation, derived from an emission factor of the power grid, or the power generation technology that would most likely be used in the absence of the project. <p>Monitored:</p> <ul style="list-style-type: none"> • Fuel consumption of the project power plant; • Electricity generation of the project power plant.
BASELINE SCENARIO <ul style="list-style-type: none"> • Power generation using natural gas, but based on less-efficient technologies than the project ones; • Power generation using fossil fuels other than natural gas; • Import of electricity from the electricity grid. 	 <p>The diagram illustrates the baseline scenario. On the left, a 'Fossil fuel' icon (flame) has an arrow pointing to a central box containing a 'Grid' icon (power lines) and a 'Power plant' icon (factory). From this central box, two arrows point to the right: one to an 'Electricity' icon (lightning bolt) and another to a 'CO2' icon (flame). The 'Electricity' icon has a second arrow pointing to another 'Electricity' icon, representing a chain of supply. The background is a light brown hatched pattern.</p>
PROJECT SCENARIO <ul style="list-style-type: none"> • Power supply to the electricity grid by a new natural-gas-fired power generation plant. 	 <p>The diagram illustrates the project scenario. On the left, a 'Natural gas' icon (flame with 'H') has an arrow pointing to a central box containing a 'Power plant' icon (factory) and a 'Grid' icon (power lines). The 'Grid' and 'Power plant' icons in this box are crossed out with a large 'X'. From this central box, two arrows point to the right: one to an 'Electricity' icon (lightning bolt) and another to a 'CO2' icon (flame). The 'Electricity' icon has a second arrow pointing to another 'Electricity' icon. On the far left, a 'Fossil fuel' icon (flame) and a 'Power plant' icon (factory) are also crossed out with a large 'X'. On the far right, a 'CO2' icon (flame) is also crossed out with a large 'X'. The background is a light green hatched pattern.</p>

AM0030 PFC emission reductions from anode effect mitigation at primary aluminium smelting facilities

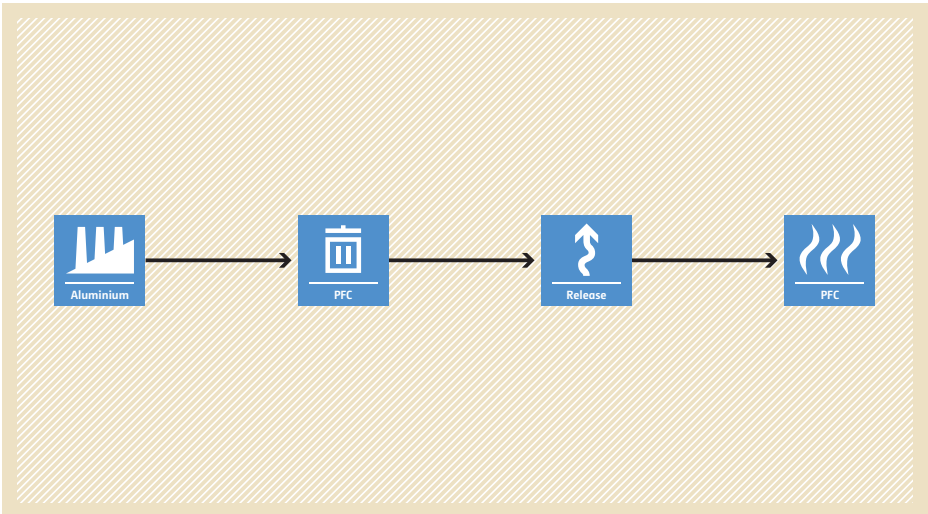
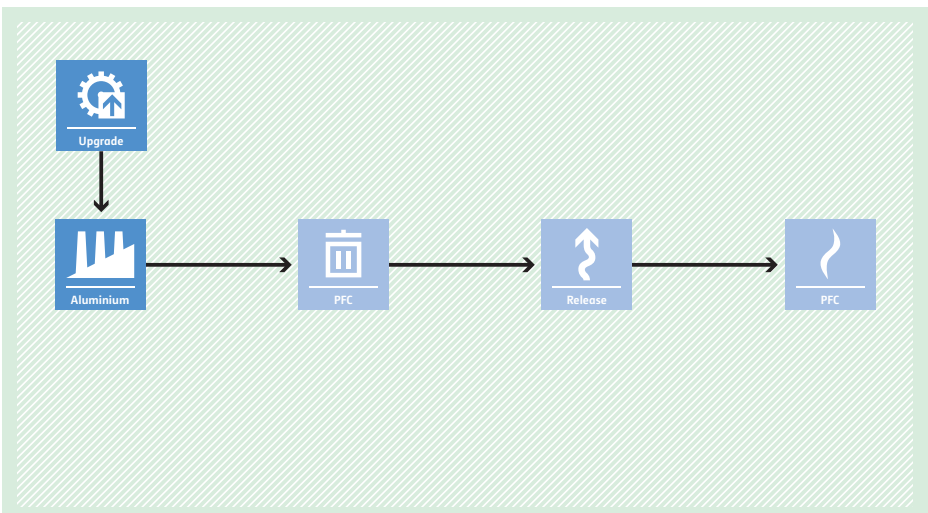
<p>Typical project(s)</p>	<p>Implementation of anode effect mitigation measures at a primary aluminium smelter (e.g. improving the algorithm of the automatic control system for smelting pots).</p>
<p>Type of GHG emissions mitigation action</p>	<ul style="list-style-type: none"> • GHG emission avoidance. <p>Avoidance of PFC emissions by anode effect mitigation.</p>
<p>Important conditions under which the methodology is applicable</p>	<ul style="list-style-type: none"> • The aluminium smelting facility started the commercial operation before 1 January 2009; • Minimum of three years of historical data is available on current efficiency, anode effect and aluminium production; • The aluminium smelting facility uses centre work pre-bake cell technology with bar brake (CWPB) or point feeder systems (PFPB); • The aluminium smelting facility has achieved an “operational stability associated to a PFC emissions level” that allows increasing the aluminium production by simply increasing the electric current in the pots.
<p>Important parameters</p>	<p>Monitored:</p> <ul style="list-style-type: none"> • Quantity of aluminium produced by the aluminium smelting facility; • Anode effect minutes per cell-day.
<p>BASELINE SCENARIO No mitigation of PFC emissions from anode effects at primary aluminium smelting facilities.</p>	 <p>The baseline scenario flowchart shows a linear process: Aluminium (represented by a factory icon) leads to PFC (represented by a trash can icon), which leads to Release (represented by an upward arrow icon), which finally leads to PFC (represented by a flame icon). The entire flowchart is set against a light brown background with a diagonal hatching pattern.</p>
<p>PROJECT SCENARIO Implementation of anode effect mitigation measures to reduce PFC emissions from aluminium smelting.</p>	 <p>The project scenario flowchart shows the same linear process as the baseline scenario: Aluminium (factory icon) leads to PFC (trash can icon), which leads to Release (upward arrow icon), which leads to PFC (flame icon). However, an 'Upgrade' icon (a gear with a house) is positioned above the Aluminium icon, with a downward arrow pointing to it, indicating that mitigation measures are implemented at the production stage. The entire flowchart is set against a light green background with a diagonal hatching pattern.</p>

AM0031 Baseline methodology for bus rapid transit projects



<p>Typical project(s)</p>	<p>Construction and operation of a new bus rapid transit system (BRT) for urban transport of passengers. Replacement, extensions or expansions of existing bus rapid transit systems (adding new routes and lines) are also allowed.</p>
<p>Type of GHG emissions mitigation action</p>	<ul style="list-style-type: none"> • Energy efficiency. • Displacement of more-GHG-intensive transportation modes by less-GHG-intensive ones.
<p>Important conditions under which the methodology is applicable</p>	<ul style="list-style-type: none"> • If biofuels are used, project buses must use the same biofuel blend (same percentage of biofuel) as commonly used by conventional comparable urban buses in the country.
<p>Important parameters</p>	<p>At validation:</p> <ul style="list-style-type: none"> • Baseline distance and transport mode, which are obtained through a comprehensive survey involving the users of the project transport system; • Specific fuel consumption, occupancy rates and travelled distances of different transport modes (including the project); • Policies affecting the baseline (i.e. modal split of passengers, fuel usage of vehicles, maximum vehicle age). <hr/> <p>Monitored:</p> <ul style="list-style-type: none"> • Number of passengers transported in the project; • Total consumption of fuel/electricity in the project.
<p>BASILINE SCENARIO Passengers are transported using a diverse transport system involving buses, trains, cars, non-motorized transport modes, etc. operating under mixed traffic conditions.</p>	<p>The diagram illustrates the baseline scenario with a light brown background. On the left, there are four icons representing transport modes: Train, Bus, Car, and Motorcycle. Lines from each icon converge and then branch out to point towards a single box on the right labeled 'CO2' with a flame icon, indicating that all these modes contribute to the total emissions.</p>
<p>PROJECT SCENARIO Passengers are transported using the newly developed bus rapid transit system that partially displaces the existing transport system operating under mixed traffic conditions.</p>	<p>The diagram illustrates the project scenario with a light green background. It shows the same four transport modes (Train, Bus, Car, Motorcycle) as in the baseline scenario. However, there is an additional 'Bus' icon placed in the center of the diagram. Lines from the Train, Car, and Motorcycle icons converge and then branch out to point towards a 'CO2' emissions box. The lines from the original 'Bus' icon and the new central 'Bus' icon also point towards the 'CO2' box, showing that the BRT system partially displaces other modes while adding its own contribution to emissions.</p>

AM0035 SF₆ emission reductions in electrical grids

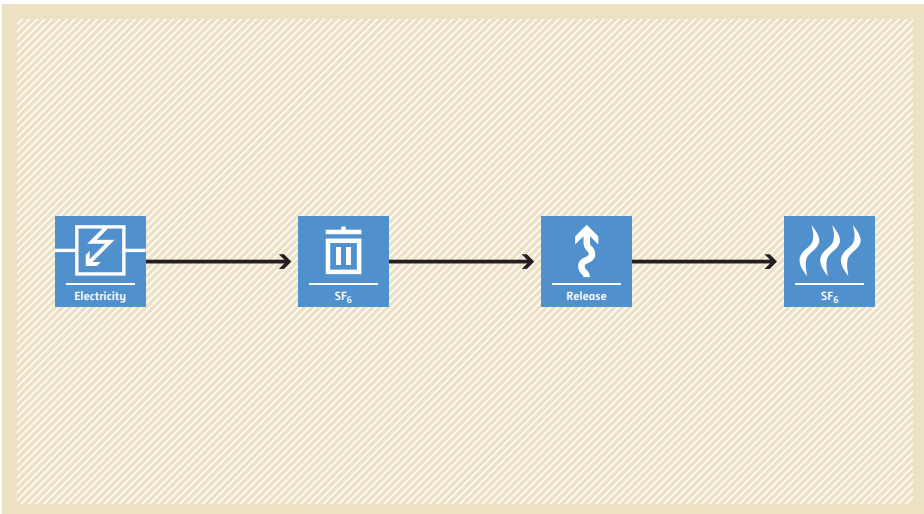
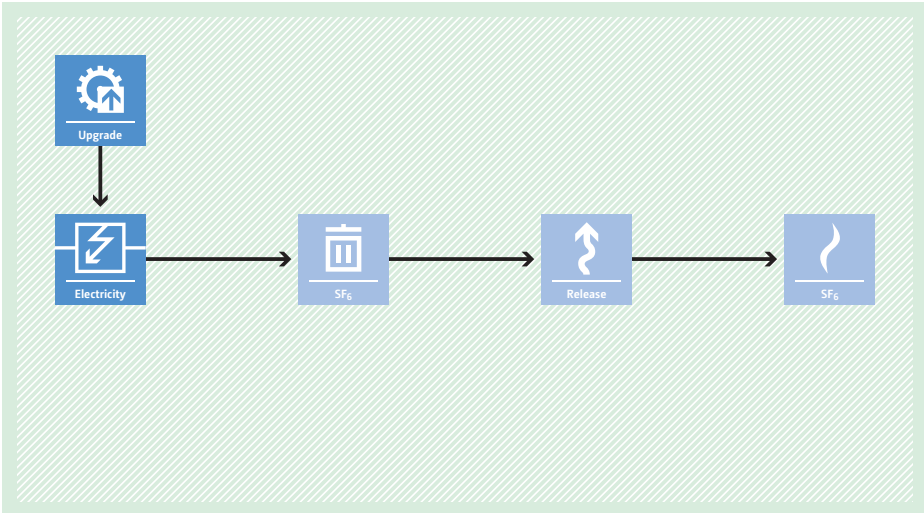
Typical project(s)	Recycling and/or leak reduction of SF ₆ in a electricity grid.
Type of GHG emissions mitigation action	<ul style="list-style-type: none"> • GHG emission avoidance. Avoidance of SF ₆ emissions by recycling and/or leak reduction.
Important conditions under which the methodology is applicable	<ul style="list-style-type: none"> • The project is implemented either in the entire grid or a verifiable distinct geographic portion of a grid; • Minimum of three years of historical data is available on the total SF₆ emissions from the grid.
Important parameters	At validation: <ul style="list-style-type: none"> • Net reduction in an SF₆ inventory for the grid; • Nameplate capacity (in kg SF₆) of equipment retired from and added to the grid.
	Monitored: <ul style="list-style-type: none"> • Update of the above parameters necessary for validation.
BASELINE SCENARIO SF ₆ emitted from leaks and/or non-recycling of SF ₆ during repair and maintenance of electricity transmission and distribution systems.	 <p>The baseline scenario flowchart shows a linear process: Electricity (represented by a lightning bolt icon) leads to SF₆ (represented by a trash can icon), which then leads to Release (represented by an upward arrow icon), resulting in SF₆ emissions (represented by wavy lines icon).</p>
PROJECT SCENARIO Recycling and/or leak-reduction of SF ₆ during repair and maintenance of electricity transmission and distribution systems.	 <p>The project scenario flowchart shows an 'Upgrade' step (represented by a gear and upward arrow icon) leading to the 'Electricity' step (lightning bolt icon). The rest of the process is identical to the baseline: Electricity leads to SF₆ (trash can icon), which leads to Release (upward arrow icon), resulting in SF₆ emissions (wavy lines icon).</p>

AM0036 Fuel switch from fossil fuels to biomass residues in heat generation equipment

<p>Typical project(s)</p>	<p>Fuel switch from fossil fuels to biomass residues in the generation of heat. Applicable activities are retrofit or replacement of existing heat generation equipment and installation of new heat generation equipment.</p>
<p>Type of GHG emissions mitigation action</p>	<ul style="list-style-type: none"> • Renewable energy; <p>Displacement of more-GHG-intensive heat generation using fossil fuel and avoidance of CH₄ emissions from anaerobic decay of biomass residues.</p>
<p>Important conditions under which the methodology is applicable</p>	<ul style="list-style-type: none"> • Heat generated in the project can only be used for power generation if power generation equipment was previously installed and is maintained throughout the crediting period; • Only biomass residues, not biomass in general, are eligible. No significant energy quantities except from transportation or mechanical treatment of the biomass residues should be required to prepare the biomass residues; • Existing heat generation equipment at the project site has either not used any biomass or has used only biomass residues (but no other type of biomass) for heat generation during the most recent three years prior to the implementation of the project; • In case of existing facilities, three years of historical data is required for the calculation of emissions reductions.
<p>Important parameters</p>	<p>At validation:</p> <ul style="list-style-type: none"> • Leakage due to diversion of biomass residues. <p>Monitored:</p> <ul style="list-style-type: none"> • Heat generated in the project; • Quantity and moisture content of the biomass residues used in the project as well as electricity and fossil fuel consumption of the project; • Project emissions from transport of biomass.
<p>BASELINE SCENARIO Heat would be produced by the use of fossil fuels. Biomass residues could partially decay under anaerobic conditions, bringing about CH₄ emissions.</p>	<p>The diagram shows a flowchart for the baseline scenario. On the left, 'Fossil fuel' (flame icon) and 'Biomass' (leaf icon) are inputs. 'Fossil fuel' leads to 'Heat' (thermometer icon). 'Biomass' leads to a box containing 'Disposal' (trash can icon) and 'Burning' (flame icon). From the 'Heat' box, arrows point to a 'Heat' box (thermometer icon) and a 'CO₂' box (flame icon). From the 'Disposal' and 'Burning' box, an arrow points to a 'CH₄' box (flame icon). A 'Heat' box (thermometer icon) is also shown between the two main heat paths.</p>
<p>PROJECT SCENARIO Use of biomass residues for heat generation avoids fossil fuel use and thereby GHG emissions. Decay of biomass residues used as fuel is avoided.</p>	<p>The diagram shows a flowchart for the project scenario. On the left, 'Biomass' (leaf icon) is the input. 'Fossil fuel' (flame icon) is crossed out with a blue 'X'. 'Biomass' leads to a 'Renewable' box (thermometer icon). 'Fossil fuel' leads to a 'Heat' box (thermometer icon), which is also crossed out with a blue 'X'. From the 'Renewable' box, arrows point to a 'Heat' box (thermometer icon) and a 'CO₂' box (flame icon), which is also crossed out with a blue 'X'. From the 'Biomass' box, an arrow points to a box containing 'Disposal' (trash can icon) and 'Burning' (flame icon), both of which are crossed out with blue 'X's. An arrow from this box points to a 'CH₄' box (flame icon), which is also crossed out with a blue 'X'. A 'Heat' box (thermometer icon) is also shown between the two main heat paths.</p>

AM0037 Flare (or vent) reduction and utilization of gas from oil wells as a feedstock

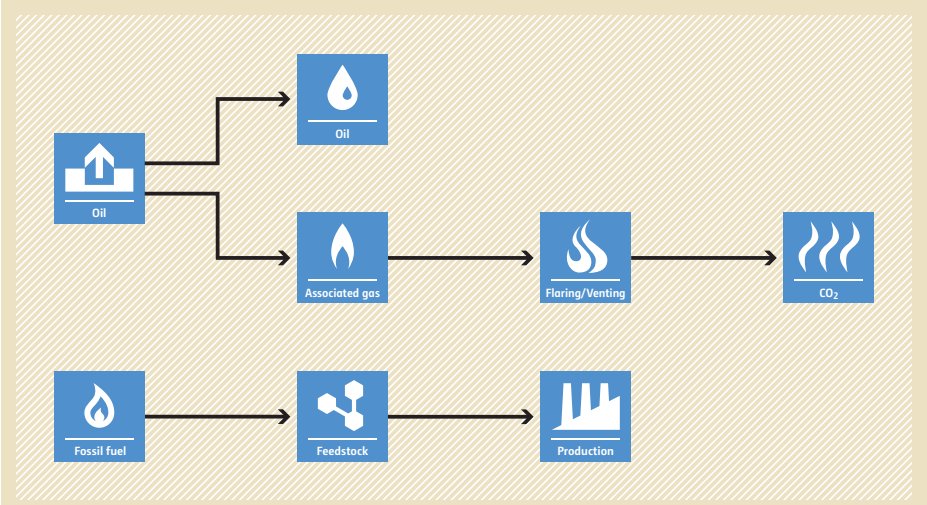
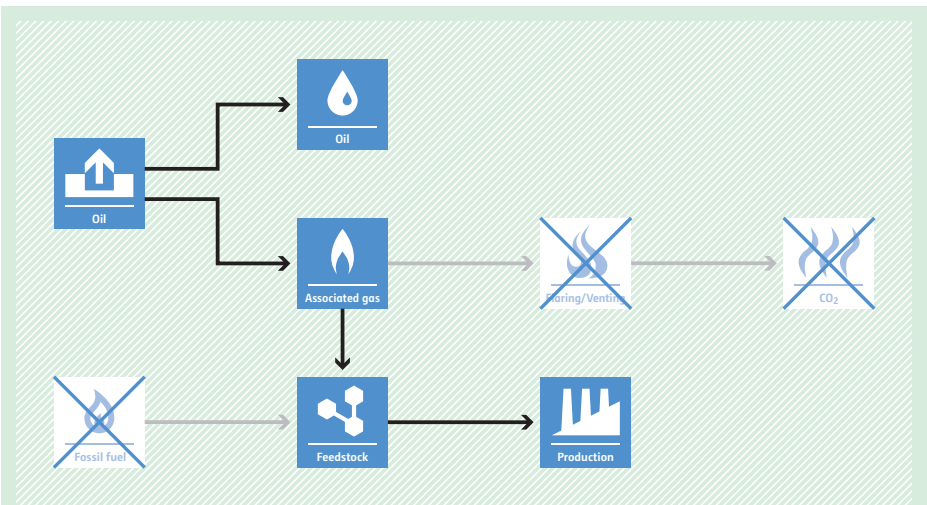
<p>Typical project(s)</p>	<p>Associated gas from oil wells that was previously flared or vented is recovered and utilized as a feedstock to produce a chemical product.</p>
<p>Type of GHG emissions mitigation action</p>	<ul style="list-style-type: none"> • Feedstock switch. <p>Avoidance of GHG emissions that would have occurred by flaring/venting the associated gas.</p>
<p>Important conditions under which the methodology is applicable</p>	<ul style="list-style-type: none"> • The associated gas from the oil well, which is used in the project, was flared or vented for the last three years prior to the start of the project; • Under the project, the previously flared (or vented) associated gas is used as feedstock and, where applicable, partly as energy source in a chemical process to produce a useful product (e.g. methanol, ethylene or ammonia).
<p>Important parameters</p>	<p>Monitored:</p> <ul style="list-style-type: none"> • Mass fraction of methane in the associated gas; • Quantity of product(s) produced in the end-use facility in the project; • Quantity and carbon content of associated gas utilized in the project, i.e. the quantity of associated gas entering the pipeline for transport to the end-use facility.
<p>BASELINE SCENARIO Associated gas from oil wells is flared or vented and other feedstock is used to produce a chemical product.</p>	 <p>The baseline scenario flowchart (set against a light brown background) illustrates the following process: An 'Oil' well (represented by a house icon) produces 'Oil' (represented by a drop icon) and 'Associated gas' (represented by a flame icon). The 'Associated gas' is then sent to 'Flaring/Venting' (represented by a flame icon), which results in 'CO₂' emissions (represented by a flame icon). Separately, 'Fossil fuel' (represented by a flame icon) is used as 'Feedstock' (represented by a molecular structure icon) for 'Production' (represented by a factory icon).</p>
<p>PROJECT SCENARIO Associated gas from oil wells is recovered and utilized as feedstock to produce a chemical product.</p>	 <p>The project scenario flowchart (set against a light green background) illustrates the following process: An 'Oil' well (represented by a house icon) produces 'Oil' (represented by a drop icon) and 'Associated gas' (represented by a flame icon). The 'Associated gas' is now sent to 'Feedstock' (represented by a molecular structure icon) for 'Production' (represented by a factory icon). The 'Flaring/Venting' and 'CO₂' steps from the baseline scenario are shown as crossed-out boxes, indicating they are avoided in this scenario.</p>

AM0038 Methodology for improved electrical energy efficiency of an existing submerged electric arc furnace used for the production of silicon and ferry alloys

<p>Typical project(s)</p>	<p>Retrofitting of existing furnaces for the production of silicon and ferry alloys including control and peripheral systems with a more efficient system.</p>
<p>Type of GHG emissions mitigation action</p>	<ul style="list-style-type: none"> • Energy efficiency; • Switch to more energy-efficient technology.
<p>Important conditions under which the methodology is applicable</p>	<ul style="list-style-type: none"> • The electricity consumed is supplied by the grid; • The quality of the raw material and products remains unchanged; • Data for at least three years preceding the implementing the project is available to estimate the baseline emission.
<p>Important parameters</p>	<p>At validation:</p> <ul style="list-style-type: none"> • Grid emission factor (can also be monitored ex post). <hr/> <p>Monitored:</p> <ul style="list-style-type: none"> • Alloys production and consumption of electricity, reductants and electrode paste; • Project-specific quality and emission factors for reductants and electrode paste.
<p>BASELINE SCENARIO Consumption of grid electricity in the submerged arc furnaces results in CO₂ emissions from the combustion of fossil fuel used to produce electricity.</p>	
<p>PROJECT SCENARIO The more-efficient submerged arc furnaces consume less electricity, and thereby, emissions from the combustion of fossil fuel used to produce electricity are reduced.</p>	

AM0042 Grid-connected electricity generation using biomass from newly developed dedicated plantations

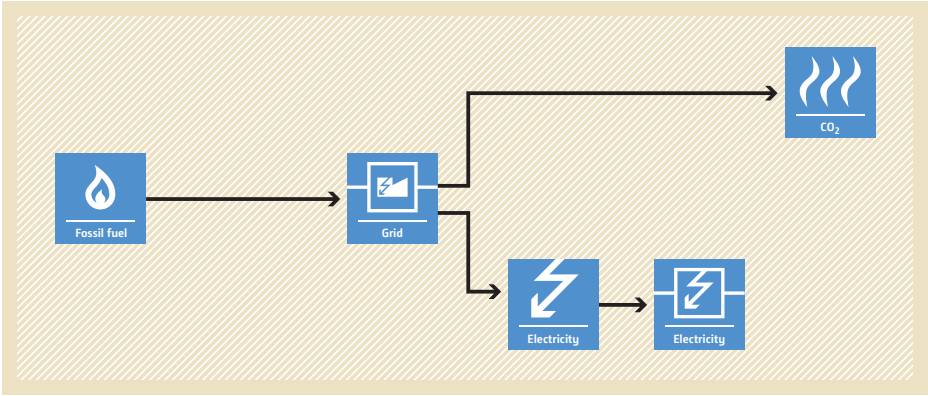
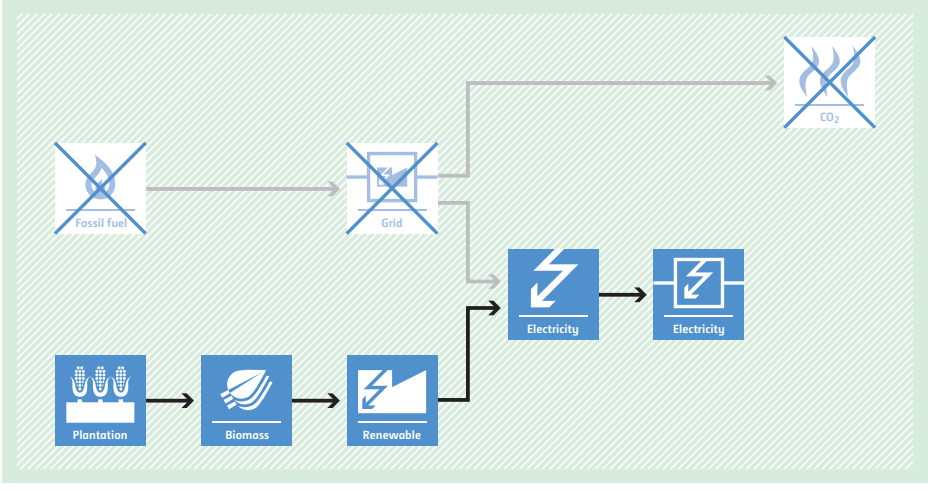
Typical project(s)	<p>Installation of a new grid-connected power plant that is mainly fired with renewable biomass from a dedicated plantation (fossil fuel or other types of biomass may be co-fired).</p>
Type of GHG emissions mitigation action	<ul style="list-style-type: none"> • Renewable energy. • Displacement of electricity that would be provided by more-GHG-intensive means.
Important conditions under which the methodology is applicable	<ul style="list-style-type: none"> • Prior to the implementation of the project, no power was generated at the project site (i.e. the project plant does not substitute or affect the operation of any existing power generation at the project site); • The dedicated plantation must be newly established as part of the project for the purpose of supplying biomass exclusively to the project; • The biomass from the plantation is not chemically processed (e.g. no production of alcohols from biomass, etc.) prior to combustion in the project plant but it may be processed mechanically or be dried; • Grazing or irrigation for the plantation is not allowed; • The land area where the dedicated plantation will be established has not been used for any agricultural or forestry activity prior to the project implementation.
Important parameters	<p>At validation:</p> <ul style="list-style-type: none"> • Grid emission factor (can also be monitored ex post). <p>Monitored:</p> <ul style="list-style-type: none"> • Electricity generated in the project; • Electricity and fossil fuel consumption of the project as well as quantity, net calorific value and moisture content of the biomass used in the project.
BASELINE SCENARIO Electricity produced by more-GHG-intensive power plants connected to the grid.	 <p>The diagram illustrates the baseline scenario. It starts with a 'Fossil fuel' icon (a flame) which feeds into a 'Grid' icon (a power plug). From the 'Grid', an arrow points to a 'CO₂' icon (flame with wavy lines). Another arrow from the 'Grid' points to an 'Electricity' icon (lightning bolt), which then feeds into another 'Electricity' icon, representing a secondary power generation stage.</p>
PROJECT SCENARIO Electricity produced by a grid-connected biomass-fired power plant.	 <p>The diagram illustrates the project scenario. It shows a 'Plantation' icon (hands holding stalks) leading to a 'Biomass' icon (leaf), which then leads to a 'Renewable' icon (lightning bolt). This 'Renewable' energy feeds into a 'Grid' icon. The 'Grid' icon is crossed out with a blue 'X'. An arrow from the 'Grid' points to a 'CO₂' icon, which is also crossed out with a blue 'X'. Another arrow from the 'Grid' points to an 'Electricity' icon, which then feeds into another 'Electricity' icon, representing a secondary power generation stage.</p>

AM0043 Leak reduction from a natural gas distribution grid by replacing old cast iron pipes or steel pipes without cathodic protection with polyethylene pipes

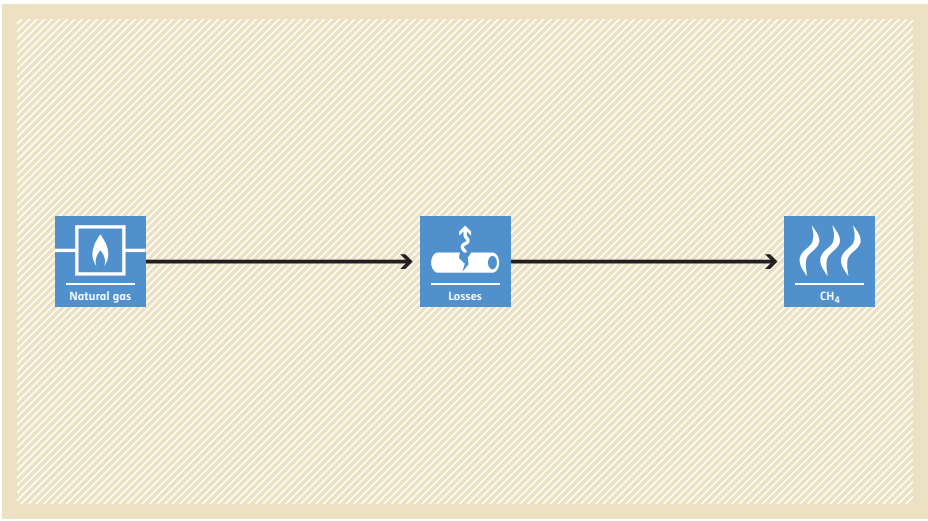
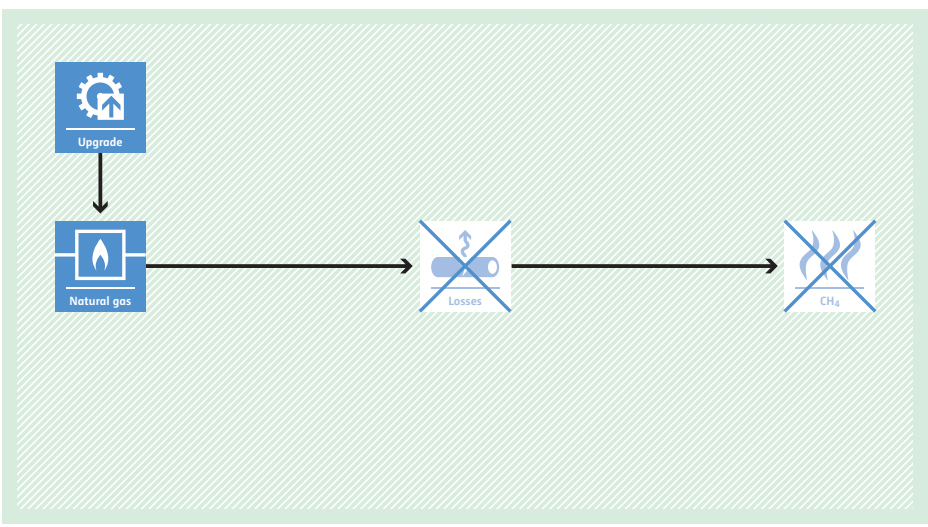
Typical project(s)	Installation of polyethylene pipes for the early replacement of leaking cast iron pipes or steel pipes without cathodic protection in a natural gas distribution network.
Type of GHG emissions mitigation action	<ul style="list-style-type: none"> • GHG emissions avoidance. • Avoidance of CH₄ emissions from leaks in natural gas transportation.
Important conditions under which the methodology is applicable	<ul style="list-style-type: none"> • The project replaces either cast iron pipes or steel pipes without cathodic protection that have been in use for 30 years with polyethylene pipes without altering the pattern and supply capacity of the system; • The replacement is not part of normal repair and maintenance, planned replacement, or due to interruptions or shortages or a switch from servicing other gases; • The distribution system does not include gas transmission pipelines or storage facilities.
Important parameters	At validation: <ul style="list-style-type: none"> • Length of pipes and number of leaks (alternative: leakage rate of the section). Monitored: <ul style="list-style-type: none"> • Length of new pipeline due to both project and procedural replacement; • Fraction of methane in the natural gas; • Pressure of natural gas in the network.
BASELINE SCENARIO Methane leaks from a natural gas network.	 <p>The diagram illustrates the baseline scenario on a light brown background. It shows a linear flow: a blue box labeled 'Natural gas' with a flame icon, followed by an arrow pointing to a blue box labeled 'Losses' with a pipe and question mark icon, and another arrow pointing to a blue box labeled 'CH₄' with a flame icon.</p>
PROJECT SCENARIO No leaks or fewer leaks in the natural gas network.	 <p>The diagram illustrates the project scenario on a light green background. It starts with a blue box labeled 'Upgrade' with a gear icon, which has a downward arrow pointing to a blue box labeled 'Natural gas' with a flame icon. An arrow then points from 'Natural gas' to a blue box labeled 'Losses' with a pipe and question mark icon, which is crossed out with a large blue 'X'. A final arrow points from 'Losses' to a blue box labeled 'CH₄' with a flame icon, which is also crossed out with a large blue 'X'.</p>

AM0044 Energy efficiency improvement projects: boiler rehabilitation or replacement in industrial and district heating sectors

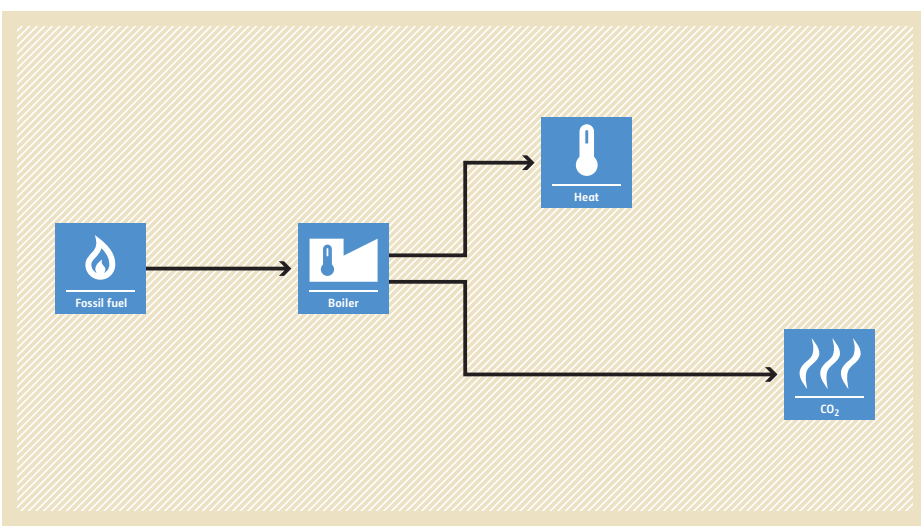
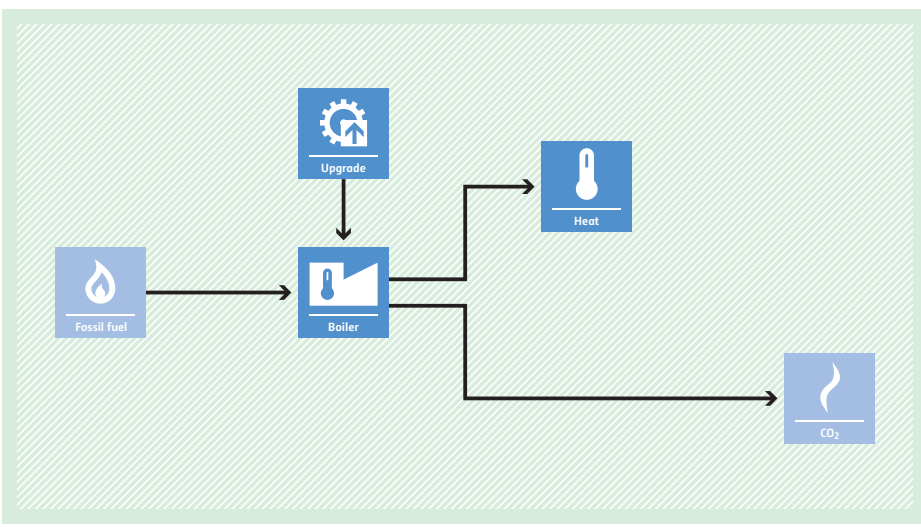
<p>Typical project(s)</p>	<p>Projects that results in thermal energy efficiency improvement of fossil-fuel-fired boilers, at multiple locations, through rehabilitation or replacement of the boilers implemented by the project participant, who may be the owner of boilers or owner of all the sites or part of the sites where the boilers are to be installed or a third party that owns all the project boilers during the project period.</p>
<p>Type of GHG emissions mitigation action</p>	<ul style="list-style-type: none"> • Energy efficiency. • Switch to more energy-efficient technology.
<p>Important conditions under which the methodology is applicable</p>	<ul style="list-style-type: none"> • The boilers that are rehabilitated or replaced under the project should have some remaining lifetime; • Only one type of fuel is used by each of the boilers included in the project boundary and no fuel switching is undertaken within the project boundary, as a part of project; • The installed capacity of each boiler shall be determined using a performance test in accordance with well-recognized international standards.
<p>Important parameters</p>	<p>Monitored</p> <ul style="list-style-type: none"> • Amount of fossil fuel consumed, net calorific value of fossil fuel, emission factor of fossil fuel, oxidation factor of fossil fuel in each boiler in the project; • Total thermal output of each boiler in the project.
<p>BASELINE SCENARIO Boiler(s) with lower efficiency will continue to operate at multiple locations, thereby consuming high amounts of fossil fuel.</p>	 <p>The diagram illustrates the baseline scenario. It shows a flow from 'Fossil fuel' (represented by a flame icon) to a 'Boiler' (represented by a boiler icon). From the boiler, two arrows branch out: one pointing to 'Heat' (represented by a thermometer icon) and another pointing to 'CO₂' (represented by a flame icon with wavy lines).</p>
<p>PROJECT SCENARIO The efficiency of boiler(s) is improved through their rehabilitation or replacement, resulting in a reduction of fossil fuel consumption and related CO₂ emissions.</p>	 <p>The diagram illustrates the project scenario. It shows a flow from 'Fossil fuel' (represented by a flame icon) to a 'Boiler' (represented by a boiler icon). An 'Upgrade' (represented by a gear icon) is shown as an input to the boiler. From the boiler, two arrows branch out: one pointing to 'Heat' (represented by a thermometer icon) and another pointing to 'CO₂' (represented by a flame icon with wavy lines). The CO₂ output is visually smaller than in the baseline scenario, indicating a reduction in emissions.</p>

AM0045 Grid connection of isolated electricity systems

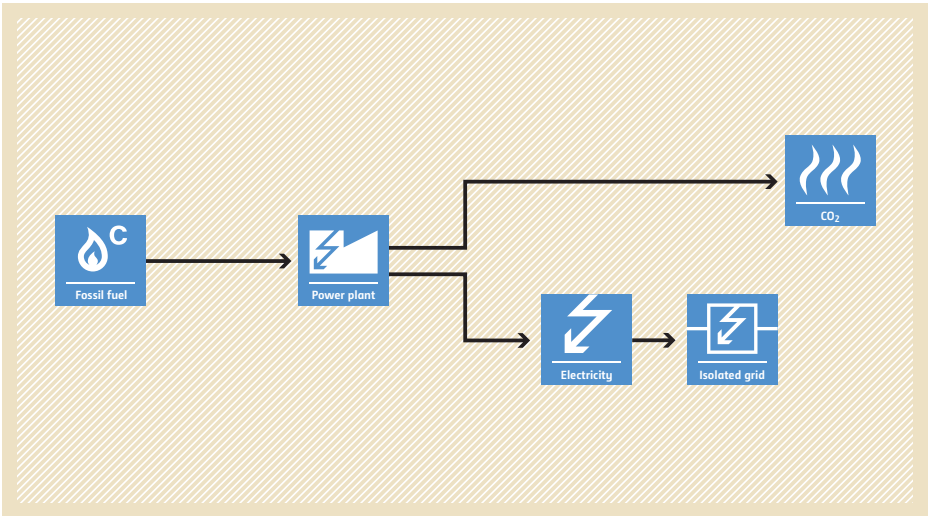
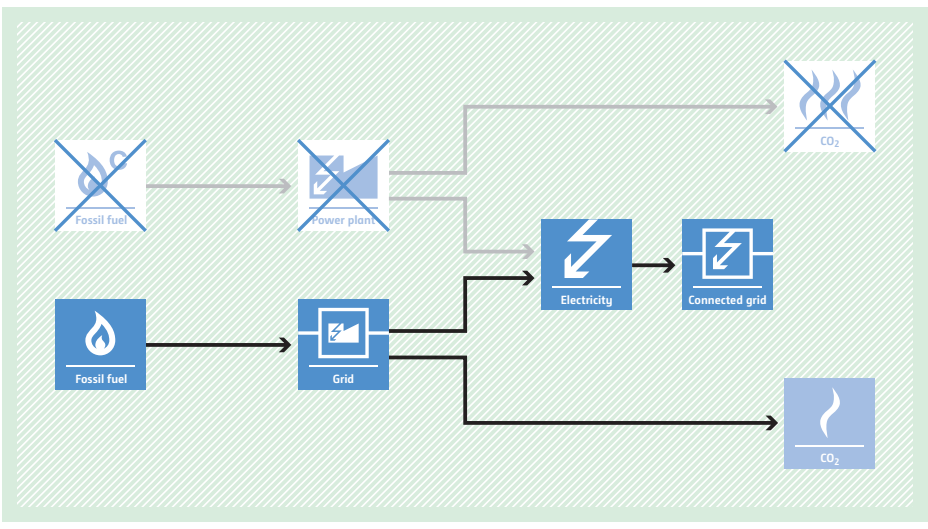
<p>Typical project(s)</p>	<p>Expansion of an interconnected grid to supply electricity generated by more-efficient, less-carbon-intensive means to an isolated electric power system.</p>
<p>Type of GHG emissions mitigation action</p>	<ul style="list-style-type: none"> Displacement of a more-GHG-intensive output. Displacement of electricity that would be provided by more-GHG-intensive means.
<p>Important conditions under which the methodology is applicable</p>	<ul style="list-style-type: none"> Renewable energy based electricity generation in the isolated systems is not displaced and its operation is not significantly affected; All fossil-fuel-fired power plants in the isolated system are 100% displaced.
<p>Important parameters</p>	<p>At validation:</p> <ul style="list-style-type: none"> Grid emission factor of isolated system before start of the project; Electricity supplied to isolated system before start of the project (three years of historic data required). <hr/> <p>Monitored:</p> <ul style="list-style-type: none"> Quantity of electricity supplied to the previously isolated system by the interconnected grid; Grid emission factor of the interconnected grid.
<p>BASELINE SCENARIO Power generation based on fossil fuel applying less-efficient technologies in isolated electricity systems.</p>	 <p>The diagram illustrates the baseline scenario. On the left, a 'Fossil fuel' icon (a flame with a 'C') has an arrow pointing to a 'Power plant' icon (a lightning bolt with a flame). From the 'Power plant', two arrows branch out: one points to a 'CO₂' icon (a flame) and the other points to an 'Electricity' icon (a lightning bolt). The 'Electricity' icon has an arrow pointing to an 'Isolated grid' icon (a lightning bolt inside a square).</p>
<p>PROJECT SCENARIO Displacement of fossil-fuel-fired power plants in the isolated grid by expansion of an interconnected grid to the isolated electricity system.</p>	 <p>The diagram illustrates the project scenario. On the left, a 'Fossil fuel' icon (a flame) has an arrow pointing to a 'Grid' icon (a lightning bolt inside a square). From the 'Grid', two arrows branch out: one points to a 'CO₂' icon (a flame) and the other points to an 'Electricity' icon (a lightning bolt). The 'Electricity' icon has an arrow pointing to a 'Connected grid' icon (a lightning bolt inside a square). Above this, a 'Fossil fuel' icon (a flame with a 'C') has an arrow pointing to a 'Power plant' icon (a lightning bolt with a flame), which has an arrow pointing to a 'CO₂' icon (a flame with a large 'X' over it). The 'Power plant' icon also has an arrow pointing to the 'Electricity' icon. The 'Connected grid' icon has an arrow pointing to the 'CO₂' icon (a flame with a large 'X' over it).</p>

AM0046 Distribution of efficient light bulbs to households



<p>Typical project(s)</p>	<p>Compact fluorescent lamps (CFLs) are sold at a reduced price, or donated to households to replace incandescent lamps (ICL).</p>
<p>Type of GHG emissions mitigation action</p>	<ul style="list-style-type: none"> • Energy efficiency. <p>Displacement of less-efficient lighting by more-efficient technology.</p>
<p>Important conditions under which the methodology is applicable</p>	<ul style="list-style-type: none"> • The households are within a distinct geographical area and are connected to the electricity grid and no other CDM project that may affect the energy efficiency of lighting in households located within the total project area has been registered; • A maximum of four CFLs can be distributed or sold to each household and these CFLs have to be more efficient and have the same or a lower lumen output as the previously used ICL; • The displaced light bulbs have a maximum rated power of 100 W and are returned to the project coordinator, who ensures destruction of the light bulbs; • Electricity consumption from lighting has to be monitored in a baseline sample group (BSG) and a project sample group (PSG). The project coordinator implements a social lottery system as an incentive among all households included in the BSG and the PSG.
<p>Important parameters</p>	<p>At validation:</p> <ul style="list-style-type: none"> • The average grid voltage in the low-voltage part of the grid, the power rating and the P-U characteristic curve of the distributed light are determined before the start of the project; • Grid emission factor (alternatively monitored). <p>Monitored:</p> <ul style="list-style-type: none"> • Electricity consumed to provide lighting (or utilization hours and power rating of lighting appliance) for household within the BSG and PSG; • Number of project ICL and scrapped light bulbs; • Technical distribution losses in the grid.
<p>BASELINE SCENARIO Less-energy-efficient light bulbs are used in households resulting in higher electricity demand.</p>	<pre> graph LR FF[Fossil fuel] --> G[Grid] G --> E[Electricity] G --> CO2[CO2] E --> L[Lighting] </pre>
<p>PROJECT SCENARIO More-energy-efficient CFLs are used in households saving electricity and thus reducing GHG emissions.</p>	<pre> graph LR FF[Fossil fuel] --> G[Grid] G --> E[Electricity] G --> CO2[CO2] E --> L[Lighting] U[Upgrade] --> L </pre>

AM0048 New cogeneration project activities supplying electricity and heat to multiple customers

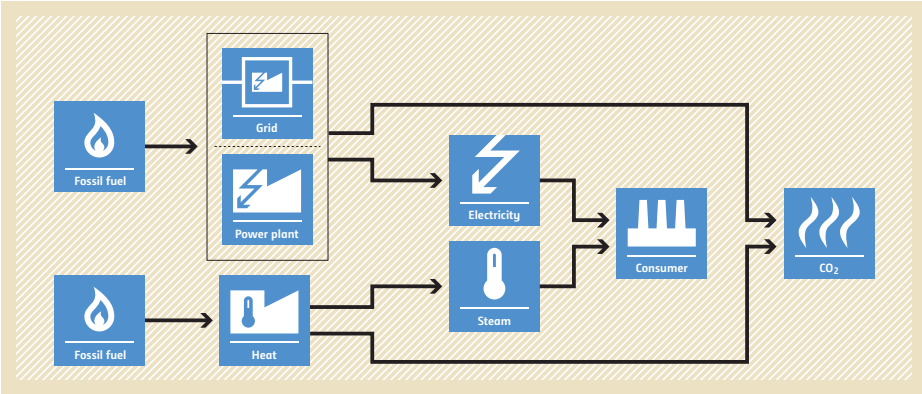
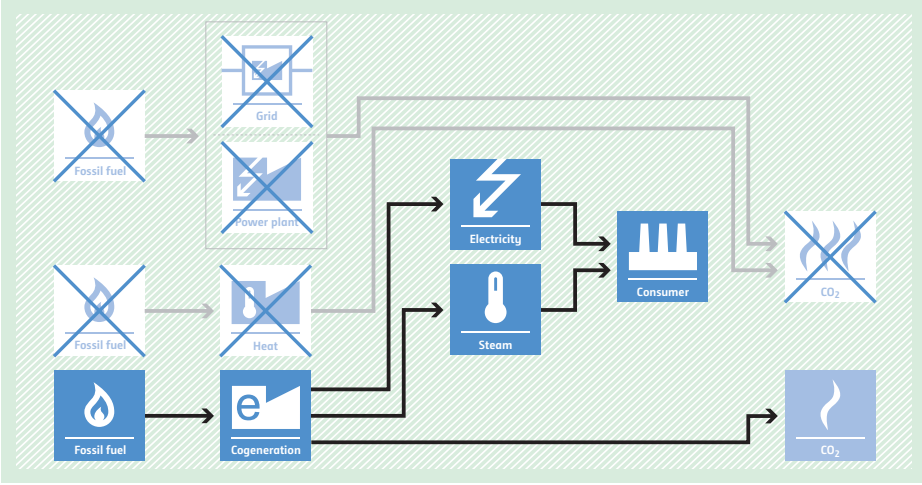
<p>Typical project(s)</p>	<p>Fossil-fuel-fired cogeneration project supplying heat and electricity to multiple project customers.</p>
<p>Type of GHG emissions mitigation action</p>	<ul style="list-style-type: none"> • Energy efficiency. • Switch to cogeneration of steam and electricity.
<p>Important conditions under which the methodology is applicable</p>	<ul style="list-style-type: none"> • Cogeneration of heat and electricity and supply to multiple users who did not previously co-generate; • Minimum three years of historical data for estimating baseline emissions; • Equipment displaced by the project is to be scrapped, unless it is kept as back-up to the project activity; • Project customers should not demand electricity and/or heat from external sources, other than the project or the grid.
<p>Important parameters</p>	<p>At validation:</p> <ul style="list-style-type: none"> • Historical fuel consumption and steam production/consumption. <p>Monitored:</p> <ul style="list-style-type: none"> • Electricity emission factor; • Quantity of electricity consumed by each project customer, from the project and from self-generation; • Quantity, temperature, specific enthalpy and pressure of steam or energy of hot water, consumed by each project customer, from the project and from self-generation; • Quantity of electricity supplied to the grid; • Quantity of fuel consumed by the project.
<p>BASELINE SCENARIO Separate heat and electricity production.</p>	
<p>PROJECT SCENARIO Cogeneration of electricity and heat.</p>	

AM0049 Methodology for gas based energy generation in an industrial facility

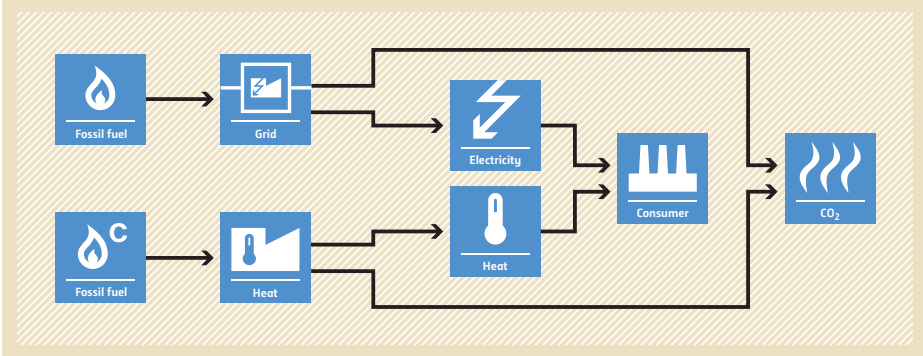
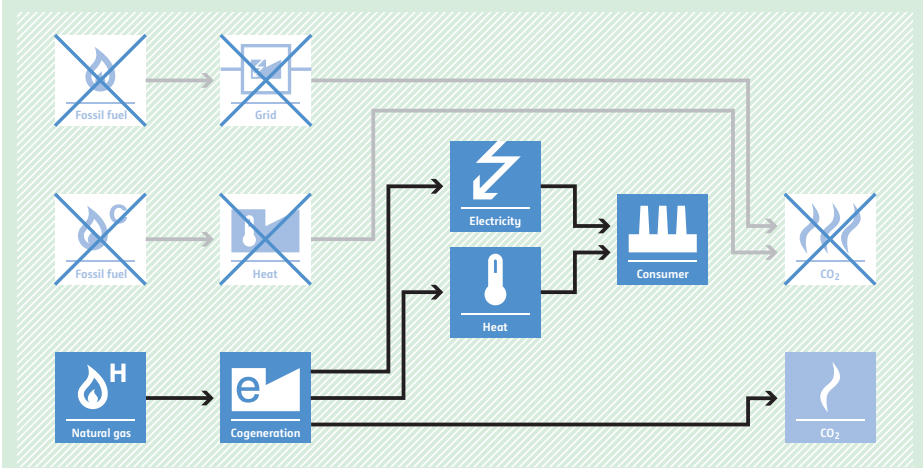
<p>Typical project(s)</p>	<p>Installation of gas-based energy generation systems, either separate or cogeneration, at an existing industrial facility to meet its own electricity and/or steam/heat demand.</p>
<p>Type of GHG emissions mitigation action</p>	<ul style="list-style-type: none"> • Fuel switch; • Energy efficiency. <p>Displacement of more-carbon-intensive fuel with less-carbon-intensive fuel.</p>
<p>Important conditions under which the methodology is applicable</p>	<ul style="list-style-type: none"> • Prior to the project implementation, the existing industrial facility produces its own thermal energy and maybe electricity, but the electricity supply is not enough to meet its own demand; • Coal or oil is replaced by natural gas or methane-rich gas, which shall be sufficiently available in the region or country; • There are no regulatory requirements for fuel switch or technology upgrade; • The project does not change the quality requirement of steam/heat; • Electricity export to the power grid, if any, is on ad-hoc basis and consists of less than 10% of the total electricity produced by the project power plant.
<p>Important parameters</p>	<p>At validation:</p> <ul style="list-style-type: none"> • Grid emission factor. <p>Monitored:</p> <ul style="list-style-type: none"> • Electricity generation and export of the project power plant; • Efficiency of the baseline and project fuel combustion systems; • Flow rate, pressure and temperature of heat carrier at inlet and outlet of waste heat generation sources; • Fuel consumption by the project plant.
<p>BASELINE SCENARIO On-site generation of heat using coal or oil and import of electricity from the grid.</p>	 <p>The diagram illustrates the baseline scenario. On the left, two boxes labeled 'Fossil fuel' (one with a flame icon, one with a flame and 'C' icon) have arrows pointing to 'Grid' and 'Heat' boxes respectively. From the 'Grid' box, an arrow points to an 'Electricity' box. From the 'Heat' box, an arrow points to a 'Heat' box. Both the 'Electricity' and 'Heat' boxes have arrows pointing to a 'Consumer' box (represented by a factory icon). From the 'Consumer' box, an arrow points to a 'CO₂' box (represented by a flame icon).</p>
<p>PROJECT SCENARIO Installation of energy generation systems, either separate or cogeneration, to supply electricity and/or steam/heat using natural gas or methane-rich gas.</p>	 <p>The diagram illustrates the project scenario. On the left, a 'Natural gas' box (flame with 'H' icon) has an arrow pointing to a 'Cogeneration' box (flame with 'e' icon). Above this, the 'Fossil fuel' and 'Grid' boxes from the baseline scenario are crossed out with a large 'X'. Similarly, the 'Fossil fuel' and 'Heat' boxes are also crossed out. From the 'Cogeneration' box, two arrows point to the 'Electricity' and 'Heat' boxes. From these two boxes, arrows point to the 'Consumer' box. From the 'Consumer' box, an arrow points to a 'CO₂' box. The 'CO₂' box from the baseline scenario is also crossed out.</p>

AM0050 Feed switch in integrated ammonia-urea manufacturing industry

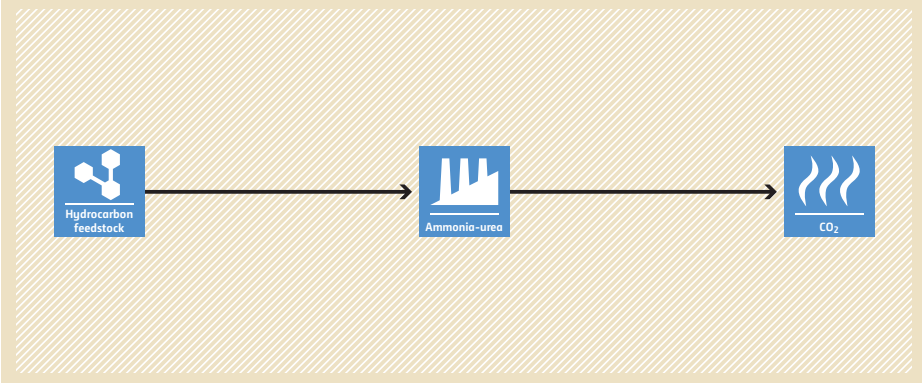
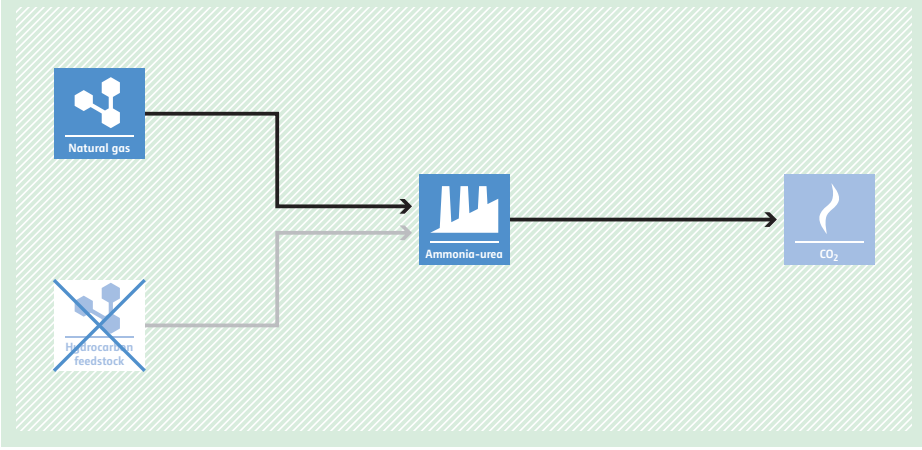
<p>Typical project(s)</p>	<p>Feed switch from existing hydrocarbon feedstock (i.e. naphtha, heavy oils, coal, lignite and coke) to natural gas, either completely or partially, in an existing integrated ammonia-urea manufacturing facility, with optional implementation of a CO₂ recovery plant within the manufacturing facility.</p>
<p>Type of GHG emissions mitigation action</p>	<ul style="list-style-type: none"> • Feedstock switch. <p>Displacement of more-GHG-intensive feedstock (naphtha, heavy oils, coal, lignite and coke) with less-GHG-intensive feedstock (natural gas).</p>
<p>Important conditions under which the methodology is applicable</p>	<ul style="list-style-type: none"> • The project activity should not result in the increase of the production capacity beyond 10% of the existing capacity, and change in production process; • Natural gas is sufficiently available in the region or country; • The integrated ammonia-urea manufacturing facility is an existing plant with a historical operation of at least three years prior to the implementation of the project; • Prior to the implementation of the project, no natural gas has been used in the integrated ammonia-urea manufacturing facility.
<p>Important parameters</p>	<p>At validation:</p> <ul style="list-style-type: none"> • Urea production in the most recent three years; • Quantity of each existing feedstock used as feed in the most recent three years; • Quantity of fuel consumed in furnaces in the most recent three years. <p>Monitored:</p> <ul style="list-style-type: none"> • Urea production in the project; • Quantity of natural gas used as feed in the project; • Quantity of fuel consumed in furnaces in the project; • Quantity and CO₂ emission factor of electricity consumed by the CO₂ recovery plant.
<p>BASELINE SCENARIO</p> <p>The integrated ammonia-urea manufacturing facility continues to use existing hydrocarbon feedstock as the feed emitting excess CO₂, not used by the urea plant, into atmosphere.</p>	 <p>The diagram shows a linear process flow. On the left, a blue icon labeled 'Hydrocarbon feedstock' has an arrow pointing to a blue icon labeled 'Ammonia-urea'. From the 'Ammonia-urea' icon, an arrow points to a blue icon labeled 'CO₂'.</p>
<p>PROJECT SCENARIO</p> <p>The feed to the integrated ammonia-urea manufacturing facility is switched from existing hydrocarbon feedstock to natural gas, if required in combination with the implementation of a CO₂ recovery, to reduce the emission of excess CO₂.</p>	 <p>The diagram shows a process flow where the feed is switched. On the left, there are two blue icons: 'Natural gas' and 'Hydrocarbon feedstock'. The 'Hydrocarbon feedstock' icon is crossed out with a blue 'X'. Arrows from both 'Natural gas' and the crossed-out 'Hydrocarbon feedstock' point to a central blue icon labeled 'Ammonia-urea'. From the 'Ammonia-urea' icon, an arrow points to a blue icon labeled 'CO₂'.</p>

AM0052 Increased electricity generation from existing hydropower stations through decision support system optimization

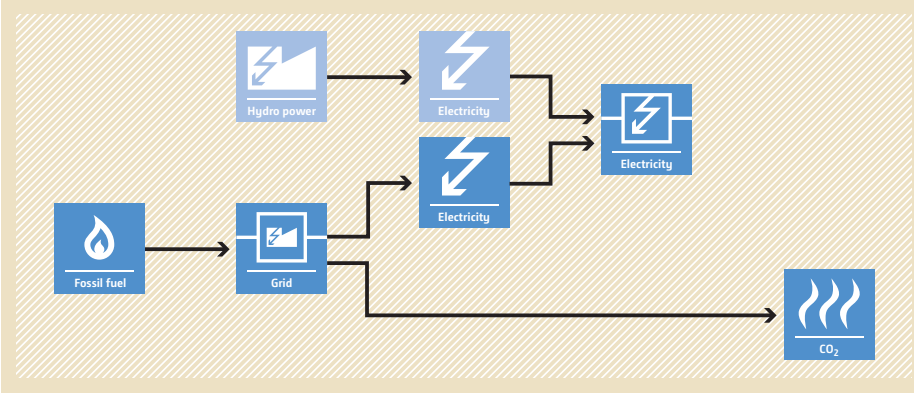
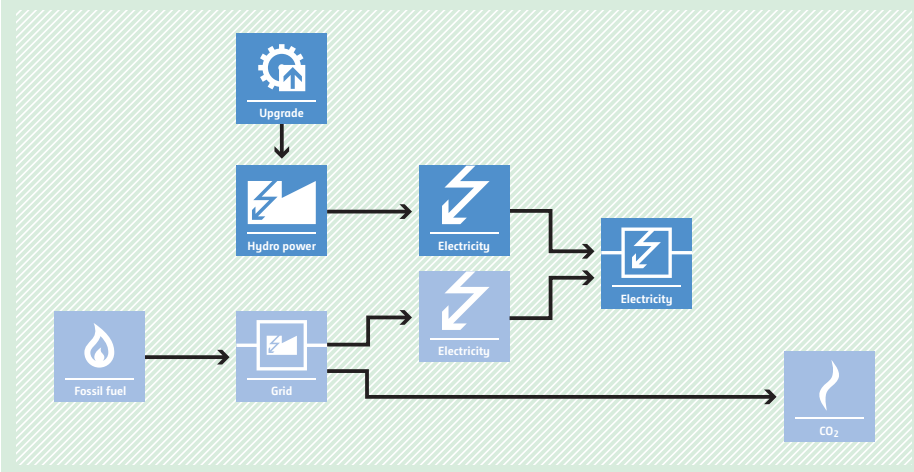
<p>Typical project(s)</p>	<p>Increased annual generation of electricity through the introduction of a Decision Support System (DSS) that optimizes the operation of the existing hydropower facility/ies, both run-of-the-river and reservoir-based type, connected to a grid.</p>
<p>Type of GHG emissions mitigation action</p>	<ul style="list-style-type: none"> • Renewable energy. <p>Displacement of electricity that would have been provided by more-GHG-intensive means.</p>
<p>Important conditions under which the methodology is applicable</p>	<ul style="list-style-type: none"> • Recorded data is available for a minimum of three years to establish the baseline relationship between water flow and power generation; • Hydropower units, covered under the project, have not undergone and will not undergo significant upgrades beyond basic maintenance (e.g. replacement of runners) that affect the generation capacity and/or expected operational efficiency levels during the crediting period; • No major changes in the reservoir size (e.g. increase of dam height) or to other key physical system elements (e.g. canals, spillways) that would affect water flows within the project boundary, have been implemented during the baseline data period or will be implemented during the crediting period.
<p>Important parameters</p>	<p>At validation:</p> <ul style="list-style-type: none"> • Grid emission factor (can also be monitored ex post); • Measurement data of headwater level, vertical opening of spillway, power output etc. from previous year before project implementation as well as power polynomial coefficients (hill diagram). <p>Monitored:</p> <ul style="list-style-type: none"> • Quantity of electricity generated by each hydropower unit in the project.
<p>BASELINE SCENARIO Additional electricity would be produced by more-GHG-intensive power plants connected to the grid.</p>	 <p>The diagram illustrates the baseline scenario. It shows a flow from 'Fossil fuel' (represented by a flame icon) and 'Hydro power' (represented by a lightning bolt icon) into a 'Grid' (represented by a lightning bolt icon). From the 'Grid', the flow goes to 'Electricity' (represented by a lightning bolt icon) and then to 'CO2' (represented by a flame icon). There are also direct arrows from 'Hydro power' to 'Electricity' and from 'Fossil fuel' to 'CO2'.</p>
<p>PROJECT SCENARIO Introduction of a Decision Support System (DSS) increases the supply of electricity generated by existing hydropower units to the grid, thereby reducing the amount of more-GHG-intensive electricity in the grid.</p>	 <p>The diagram illustrates the project scenario. It shows an 'Upgrade' (represented by a gear icon) leading to an increase in 'Hydro power' (represented by a lightning bolt icon). This 'Hydro power' feeds into the 'Grid' (represented by a lightning bolt icon). The 'Grid' also receives input from 'Fossil fuel' (represented by a flame icon). From the 'Grid', the flow goes to 'Electricity' (represented by a lightning bolt icon) and then to 'CO2' (represented by a flame icon). There are also direct arrows from 'Hydro power' to 'Electricity' and from 'Fossil fuel' to 'CO2'.</p>

AM0053 Biogenic methane injection to a natural gas distribution grid

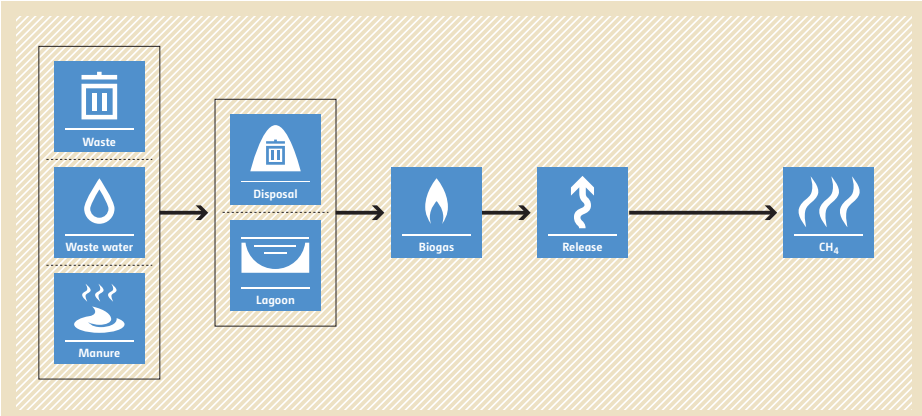
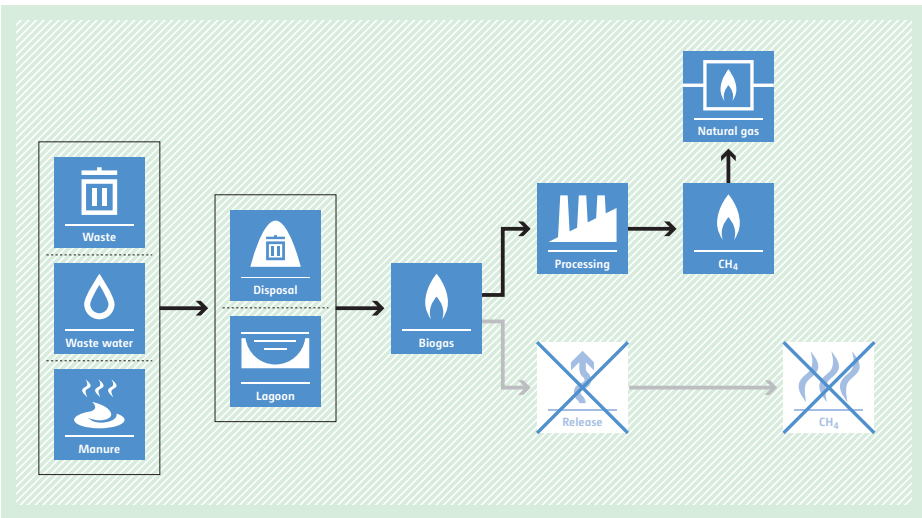
<p>Typical project(s)</p>	<p>Recovering of biogas generated by anaerobic decomposition of organic matter in wastewater treatment systems, animal waste management systems, etc., processing and upgrading the biogas to the quality of natural gas and distributing it as energy source via a natural gas distribution grid.</p>
<p>Type of GHG emissions mitigation action</p>	<ul style="list-style-type: none"> • Renewable energy; • GHG emission avoidance. <p>Avoidance of CH₄ emissions and displacement of use of natural gas in a natural gas distribution grid.</p>
<p>Important conditions under which the methodology is applicable</p>	<ul style="list-style-type: none"> • The biogas was either vented or flared prior to implementation of the project activity and would continue to be either vented or flared in the absence of the project activity; • The geographical extent of the natural gas distribution grid is within the host country; • One or several of the following technologies are used to upgrade biogas to natural gas quality: pressure swing adsorption; absorption with/without water circulation; absorption with water, with or without water recirculation; membrane CO₂ removal technology.
<p>Important parameters</p>	<p>Monitored:</p> <ul style="list-style-type: none"> • Quantity and net calorific value of upgraded biogas injected to the natural gas distribution grid; • Quantity of biogas captured at the source of biogas generation; • Concentration of methane in biogas at the source of biogas generation.
<p>BASELINE SCENARIO Biogas is vented or flared and natural gas distribution grid is supplied by natural gas extracted from gas wells.</p>	 <p>The baseline scenario flowchart shows a process starting with three input boxes: 'Waste' (trash can icon), 'Waste water' (water drop icon), and 'Manure' (cow icon). Arrows from these boxes point to a central box containing 'Disposal' (trash can icon) and 'Lagoon' (pond icon). From this central box, an arrow points to a 'Biogas' box (flame icon). From the 'Biogas' box, an arrow points to a 'Release' box (upward arrow icon). From the 'Release' box, an arrow points to a 'CH₄' box (flame icon).</p>
<p>PROJECT SCENARIO Biogas is recovered, processed, upgraded and supplied to the natural gas distribution grid and replaces additional natural gas from gas wells.</p>	 <p>The project scenario flowchart follows the same initial steps as the baseline: 'Waste', 'Waste water', and 'Manure' feed into 'Disposal' and 'Lagoon', which produce 'Biogas'. From the 'Biogas' box, an arrow points to a 'Processing' box (factory icon). From 'Processing', an arrow points to a 'CH₄' box (flame icon), which then points to a 'Natural gas' box (flame icon). A separate arrow from the 'Biogas' box points to a 'Release' box (upward arrow icon), which is crossed out with a blue 'X'. An arrow from this crossed-out 'Release' box points to a crossed-out 'CH₄' box (flame icon), also marked with a blue 'X', indicating that these emissions are avoided in the project scenario.</p>

AM0055 Recovery and utilization of waste gas in refinery or gas plant

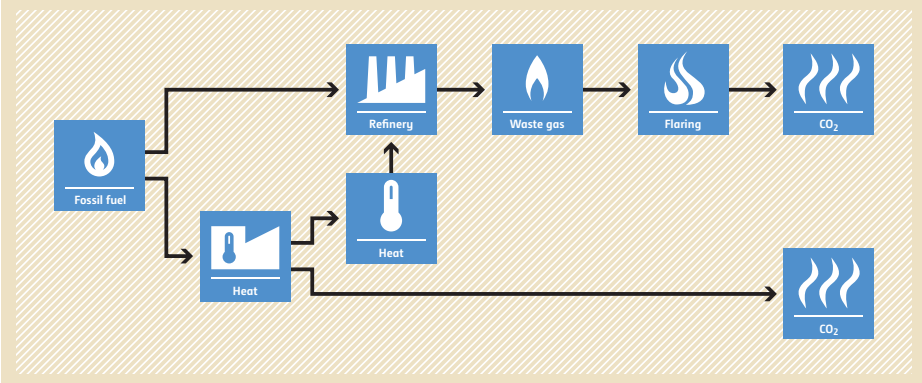
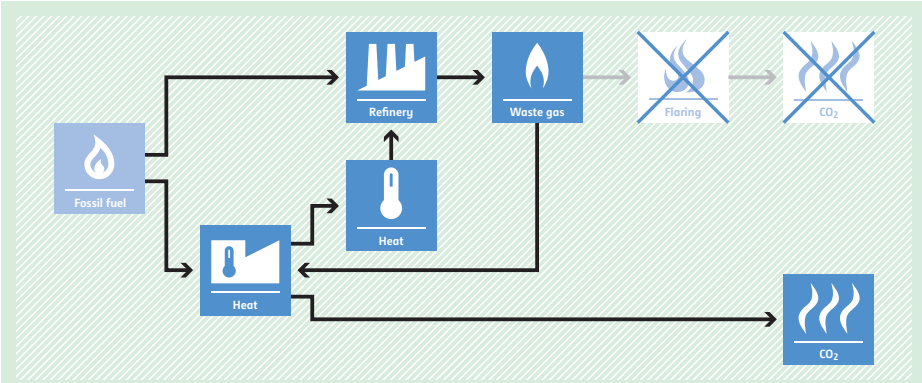
<p>Typical project(s)</p>	<p>The project activity is implemented in existing refinery facilities or gas plants to recover waste gas, which is characterized by its low pressure or a low heating value and that is currently being flared to generate process heat in element process(es) (e.g. for the purpose of steam generation by a boiler or hot air generation by a furnace). Recovered waste gas is a by-product generated in several processing units of the refinery or gas plant.</p>
<p>Type of GHG emissions mitigation action</p>	<ul style="list-style-type: none"> • Energy efficiency. • Displacement of fossil fuel used for heat production by recovered waste gas.
<p>Important conditions under which the methodology is applicable</p>	<ul style="list-style-type: none"> • Waste gases from the refinery or gas plant, used under the project activity, were flared (not vented) for the last three years prior to the implementation of the project activity; • The waste gas recovery device is placed just before the flare header (with no possibility of diversions of the recovered gas flow) and after all the waste gas generation devices; • The recovered waste gas replaces fossil fuel that is used for generating heat for processes within the same refinery or gas plant; • The composition, density and flow of waste gas are measurable.
<p>Important parameters</p>	<p>At validation:</p> <ul style="list-style-type: none"> • Historical annual average amount of waste gas sent to flares before the project implementation. <p>Monitored:</p> <ul style="list-style-type: none"> • Parameters to calculate the emission factor for consumed electricity; • Amount and composition of recovered waste gas (e.g. density, LHV) and data needed to calculate the emission factor of fossil fuel used for process heating and steam generation within the refinery or gas plant.
<p>BASELINE SCENARIO Use of fossil fuel to generate process heat. Waste gas is flared.</p>	 <p>The diagram illustrates the baseline scenario. It starts with 'Fossil fuel' (represented by a flame icon) which is used to generate 'Heat' (represented by a thermometer icon). This heat is then used in a 'Refinery' (represented by a factory icon). The refinery produces 'Waste gas' (represented by a flame icon). This waste gas is then sent to 'Flaring' (represented by a flame icon), which results in 'CO2' emissions (represented by a flame icon).</p>
<p>PROJECT SCENARIO Use of recovered waste gas to generate process heat. Thereby, fossil fuel usage is reduced and waste gas is not flared anymore.</p>	 <p>The diagram illustrates the project scenario. It starts with 'Fossil fuel' (represented by a flame icon) which is used to generate 'Heat' (represented by a thermometer icon). This heat is then used in a 'Refinery' (represented by a factory icon). The refinery produces 'Waste gas' (represented by a flame icon). This waste gas is then used to generate 'Heat' (represented by a thermometer icon), which is then used in the refinery. This process reduces the need for fossil fuel. The waste gas is not flared, resulting in reduced 'CO2' emissions (represented by a flame icon).</p>

AM0056 Efficiency improvement by boiler replacement or rehabilitation and optional fuel switch in fossil fuel-fired steam boiler systems

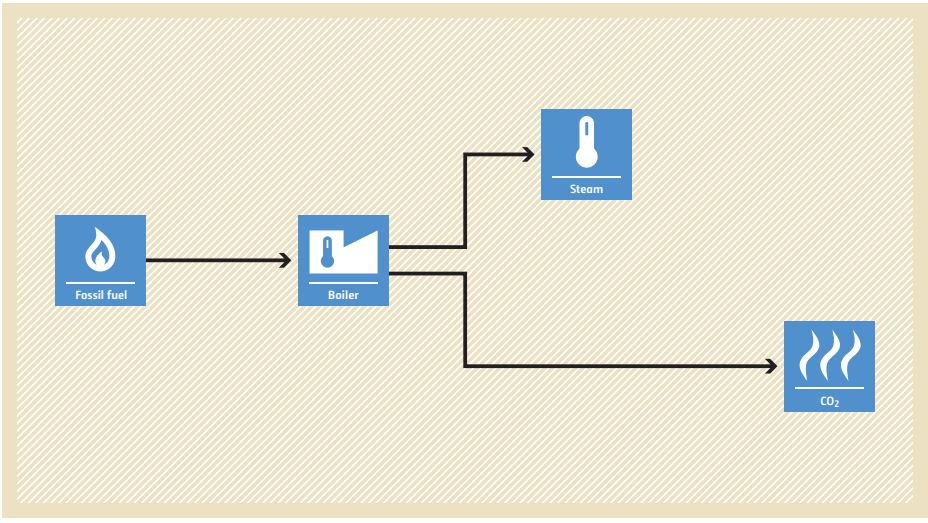
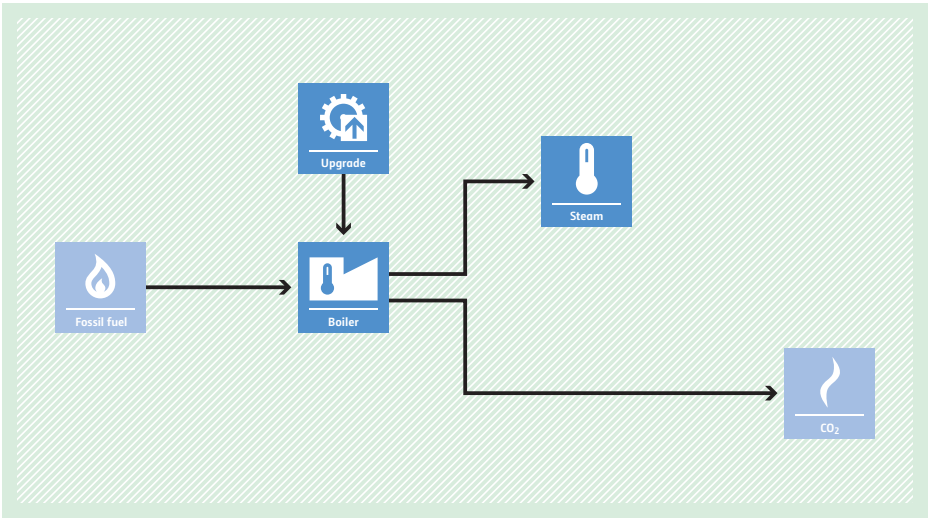
<p>Typical project(s)</p>	<p>Complete replacement of existing boilers by new boilers with a higher efficiency in an existing facility with steam demands or retrofitting of existing boilers in order to increase their efficiency; or a combination with one or both activities described above and a switch in the type of fossil fuel used to fuel boilers.</p>
<p>Type of GHG emissions mitigation action</p>	<ul style="list-style-type: none"> • Energy efficiency. • Technology switch resulting in an increase in energy efficiency.
<p>Important conditions under which the methodology is applicable</p>	<ul style="list-style-type: none"> • The project boilers utilize fossil fuels to produce steam; • The compliance with national/local regulations are not the cause of the development of the project; • Steam quality (i.e. steam pressure and temperature) is the same prior and after the implementation of the project; • Only one type of fossil fuel is used in all boilers included in the project boundary.
<p>Important parameters</p>	<p>Monitored:</p> <ul style="list-style-type: none"> • Quantity of fuel used in the boilers; • Quantity of steam produced; • Temperature and pressure of the steam produced.
<p>BASELINE SCENARIO Continuation of the current situation; i.e. use of the existing boilers without fossil fuel switch, replacement or retrofit of the boilers.</p>	 <p>The diagram illustrates the baseline scenario. It shows a flow from 'Fossil fuel' (represented by a flame icon) to a 'Boiler' (represented by a boiler icon). From the boiler, two arrows branch out: one pointing to 'Steam' (represented by a thermometer icon) and another pointing to 'CO2' (represented by a flame icon with wavy lines). The entire process is set against a light brown background with a diagonal hatching pattern.</p>
<p>PROJECT SCENARIO Complete replacement of boilers, and/or retrofitting of an existing steam generating system results in higher efficiency and less consumption of fossil fuel (fuel switch may also be an element of the project scenario).</p>	 <p>The diagram illustrates the project scenario. It shows a flow from 'Fossil fuel' (represented by a flame icon) to a 'Boiler' (represented by a boiler icon). Above the boiler is an 'Upgrade' icon (represented by a gear and a house). An arrow points from the 'Upgrade' icon down to the 'Boiler' icon, indicating an improvement in the boiler's efficiency. From the boiler, two arrows branch out: one pointing to 'Steam' (represented by a thermometer icon) and another pointing to 'CO2' (represented by a flame icon with wavy lines). The entire process is set against a light green background with a diagonal hatching pattern.</p>

AM0057 Avoided emissions from biomass wastes through use as feed stock in pulp and paper, cardboard, fibreboard or bio-oil production

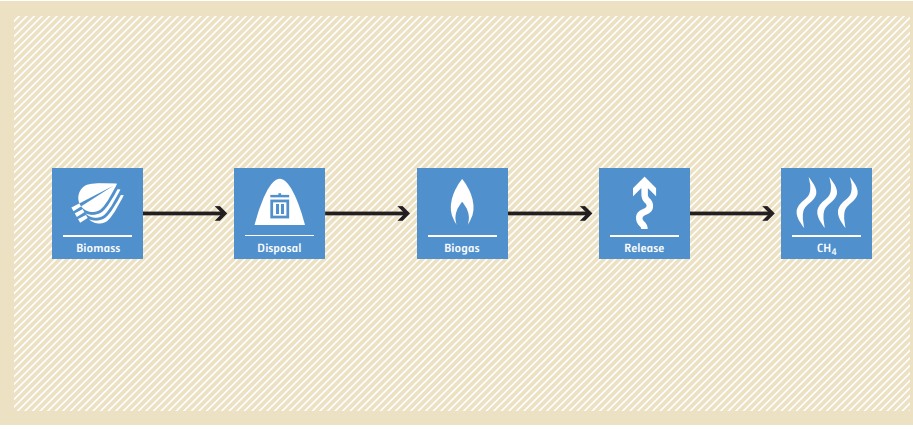
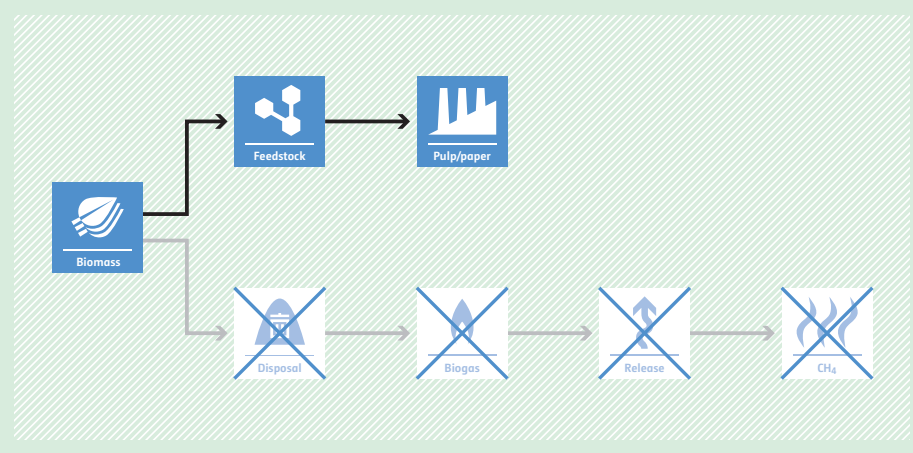
<p>Typical project(s)</p>	<p>Agricultural wastes are used as feed stock for pulp, paper, cardboard, fibreboard or bio-oil production in a new facility, where the end product is similar in characteristics and quality to existing high quality products in the market and does not require special use or disposal methods.</p>
<p>Type of GHG emissions mitigation action</p>	<ul style="list-style-type: none"> • GHG emission avoidance. • Avoidance of CH₄ emissions.
<p>Important conditions under which the methodology is applicable</p>	<ul style="list-style-type: none"> • A new production facility is being constructed; • Waste is not stored in conditions that would generate methane; • Production does not involve processes that emit significant additional greenhouse gas emissions except from those arising directly from pyrolysis (bio-oil only) processes that were also used in the baseline or associated with electricity or fossil fuel consumption; • If biomass is combusted for the purpose of providing heat or electricity to the plant, then the biomass fuel is derived from biomass residues; • In the case of bio-oil, the pyrolyzed residues (char) will be further combusted and the energy derived thereof used in the project.
<p>Important parameters</p>	<p>Monitored:</p> <ul style="list-style-type: none"> • Quantity of waste used as feedstock; • Fossil fuel and electricity consumption; • Transportation parameter – distance, fuel type and load details; • Agricultural waste residues – produced in the region, used in and outside the project and surplus.
<p>BASELINE SCENARIO Agricultural residues are left to decay anaerobically.</p>	 <p>The baseline scenario flowchart shows a linear process starting with 'Biomass' (represented by a leaf icon). An arrow points to 'Disposal' (represented by a trash can icon). Another arrow points to 'Biogas' (represented by a flame icon). A third arrow points to 'Release' (represented by an upward arrow icon). A final arrow points to 'CH₄' (represented by a flame icon with 'CH₄' text below it). The entire flowchart is set against a light brown background with a diagonal hatching pattern.</p>
<p>PROJECT SCENARIO Agricultural residues are used as feedstock in a new facility for producing paper, pulp, cardboard, fibreboard or bio-oil.</p>	 <p>The project scenario flowchart shows a branching process starting with 'Biomass' (represented by a leaf icon). One arrow points to 'Feedstock' (represented by a hexagonal molecular structure icon), which then points to 'Pulp/paper' (represented by a factory icon). A second arrow from 'Biomass' points to a crossed-out 'Disposal' icon (trash can with a red X). This is followed by a sequence of crossed-out icons: 'Biogas' (flame with red X), 'Release' (upward arrow with red X), and 'CH₄' (flame with red X). The entire flowchart is set against a light green background with a diagonal hatching pattern.</p>

AM0058 Introduction of a new primary district heating system



<p>Typical project(s)</p>	<p>A new primary district heating system supplied by previously unused heat from a fossil-fuel-fired power plant is introduced. It replaces fossil-fuel-fired heat only boilers.</p>
<p>Type of GHG emissions mitigation action</p>	<ul style="list-style-type: none"> • Energy efficiency. • Displacement of fossil-fuel-based heat generation by utilization of waste heat.
<p>Important conditions under which the methodology is applicable</p>	<ul style="list-style-type: none"> • The heat supplied by the project is predominantly from a grid connected power plant with three years of operation history and no use of waste heat and can be supplemented by new heat-only boilers; • Both power plant and boilers use only one type of fuel; • The heat is used for heating and/or tap water supply in the residential and/or commercial buildings, but not for industrial production processes.
<p>Important parameters</p>	<p>At validation:</p> <ul style="list-style-type: none"> • Efficiency of the heat supply and fuel types in the baseline; • Minimum and maximum power generation during the last three years. <p>Monitored:</p> <ul style="list-style-type: none"> • Quantity of heat from the cogeneration plant and from all heat only/peak load boilers in the project; • Total area of all the buildings in the project; • Quantity of heat supplied from each sub-station to the buildings; • Quantity of electricity supplied to the grid by the project.
<p>BASELINE SCENARIO Fossil fuel is used in a power plant that only supplies grid electricity; fossil fuel is used in individual boilers that supply heat to users.</p>	
<p>PROJECT SCENARIO Fossil fuel is used in a power plant that supplies both electricity to the grid and heat to individual users. Fossil fuel previously used in individual boilers is no longer used.</p>	

AM0059 Reduction in GHGs emission from primary aluminium smelters

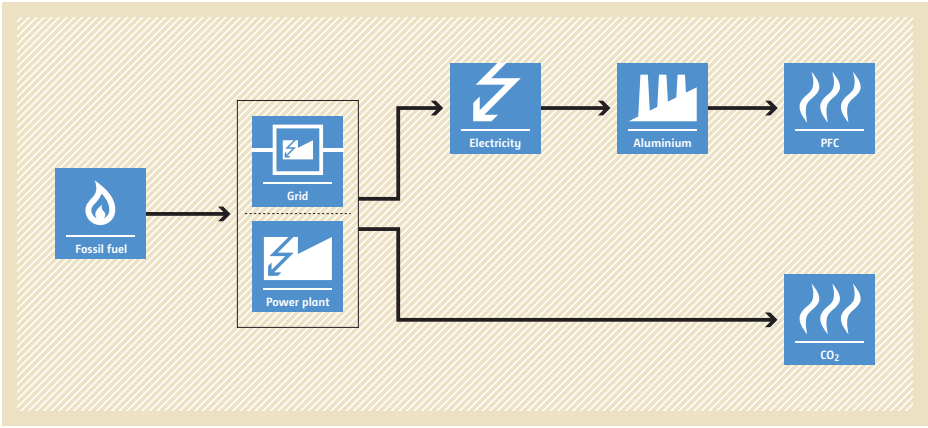
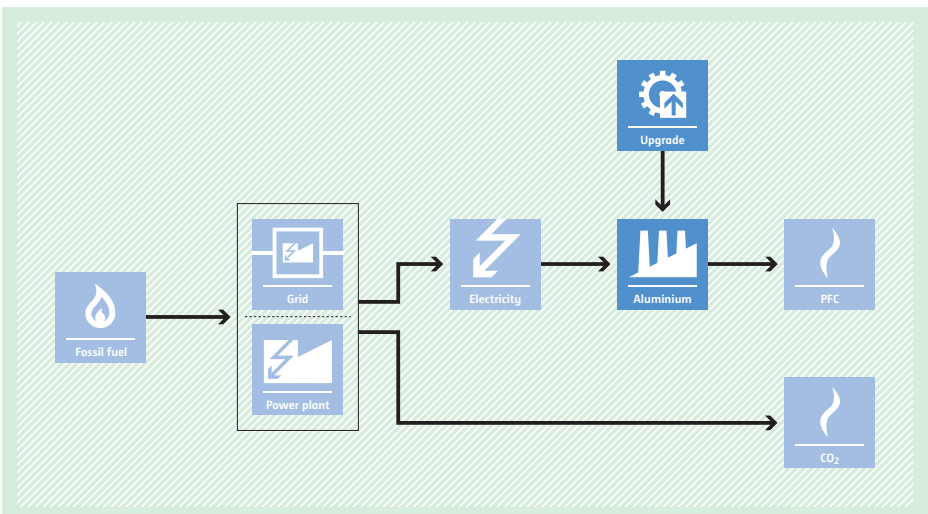
<p>Typical project(s)</p>	<p>Technology improvement at a primary aluminium smelter (PFPB, CWPB, SWPB, VSS or HSS) using computerized controls or improved operating practices, to reduce PFC emissions and/or to improve electrical energy efficiency.</p>
<p>Type of GHG emissions mitigation action</p>	<ul style="list-style-type: none"> • Energy efficiency; • GHG emission avoidance. <p>Avoidance of PFC emissions and electricity savings leading to less GHG emissions.</p>
<p>Important conditions under which the methodology is applicable</p>	<ul style="list-style-type: none"> • The project is limited to changes of the smelting technology; • At least three years of historical data for estimating baseline emissions are available.
<p>Important parameters</p>	<p>At validation:</p> <ul style="list-style-type: none"> • If less than 95% of the anode effects are manually terminated, number and duration of anode effect or anode effect over-voltage, and current efficiency; • PFC emissions; • If applicable: grid emission factor (can also be monitored ex post). <p>Monitored:</p> <ul style="list-style-type: none"> • Quantity of aluminium produced in the project; • Quantity of electricity imported from captive plants and the grid; • PFC emissions; • If applicable: electricity factor for captive generated electricity.
<p>BASELINE SCENARIO Electricity is consumed to produce aluminium and the production process leads to PFC emissions.</p>	 <p>The diagram illustrates the baseline scenario. It starts with 'Fossil fuel' (represented by a flame icon) entering a 'Power plant' (represented by a lightning bolt icon). The power plant outputs 'Electricity' (represented by a lightning bolt icon) to a 'Grid' (represented by a lightning bolt icon). From the grid, electricity flows to an 'Aluminium' smelter (represented by a factory icon). The smelter produces 'Aluminium' (represented by a factory icon) and emits 'PFC' (represented by a flame icon). Additionally, the power plant emits 'CO₂' (represented by a flame icon).</p>
<p>PROJECT SCENARIO Less electricity is consumed to produce aluminium and the production process leads to less PFC emissions.</p>	 <p>The diagram illustrates the project scenario. It follows the same path as the baseline scenario, but includes an 'Upgrade' step (represented by a gear icon) before the electricity reaches the 'Aluminium' smelter. This upgrade results in reduced PFC emissions from the smelter compared to the baseline scenario. The power plant and grid components remain the same as in the baseline scenario.</p>

AM0060 Power saving through replacement by energy efficient chillers

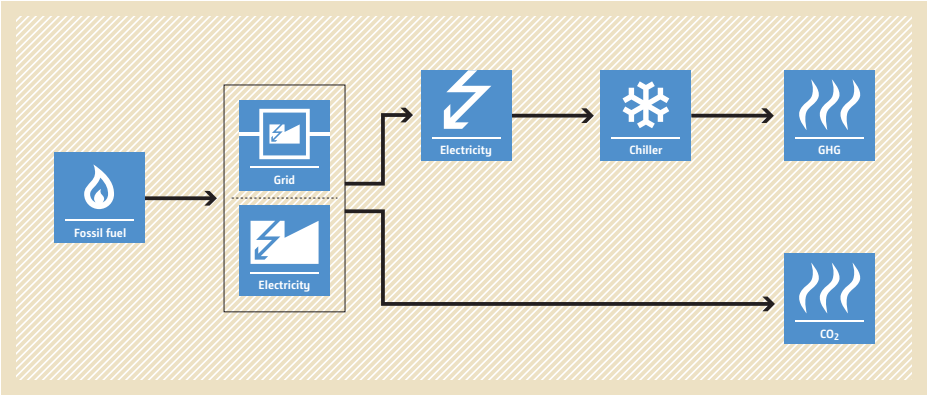
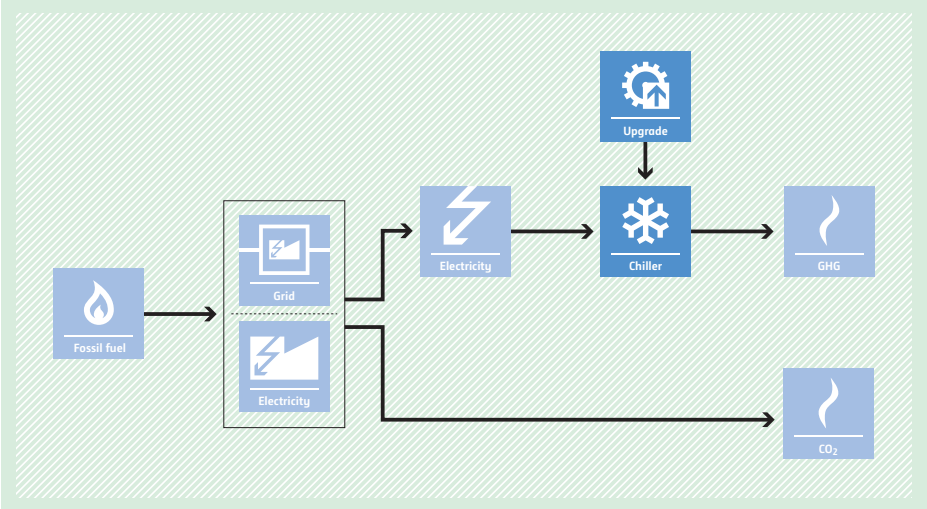
<p>Typical project(s)</p>	<p>The one-to-one replacement of existing electricity-driven chillers by more-energy-efficient new chillers with similar rated output capacity to the existing ones.</p>
<p>Type of GHG emissions mitigation action</p>	<ul style="list-style-type: none"> • Energy efficiency. <p>Electricity savings through energy efficiency improvement.</p>
<p>Important conditions under which the methodology is applicable</p>	<ul style="list-style-type: none"> • For each chiller replacement, the rated output capacity of the new chiller is not significantly larger or smaller (maximum $\pm 5\%$) than the existing chiller; • The chiller is used to generate chilled water or a water/antifreeze mixture (e.g. water with addition of glycol) for process cooling or air conditioning; • The existing and new chillers are driven by electrical energy; • The existing chillers are functioning and fully operational and can continue to operate for several years if regular maintenance is undertaken; • The existing chillers are destroyed, and the refrigerant contained in the existing chiller will be recovered and destroyed, or stored in suitable containers.
<p>Important parameters</p>	<p>At validation:</p> <ul style="list-style-type: none"> • Power consumption function of the existing chillers; • Grid emission factor (can also be monitored ex post). <p>Monitored:</p> <ul style="list-style-type: none"> • Average chiller output of the new chillers; • Average inlet temperature of condensing water of the new chillers; • Average inlet and outlet temperature of chilled water supplied by the new chillers.
<p>BASELINE SCENARIO Continued operation of the existing, less-energy-efficient chillers.</p>	 <p>The diagram illustrates the baseline scenario. It starts with 'Fossil fuel' (represented by a flame icon) which is used to generate 'Grid' electricity (represented by a lightning bolt icon). This 'Grid' electricity is then used to power a 'Chiller' (represented by a snowflake icon), which produces 'GHG' emissions (represented by a flame icon). Additionally, 'Grid' electricity is also shown being used to produce 'CO2' emissions (represented by a flame icon).</p>
<p>PROJECT SCENARIO Operation of energy-efficient chillers, resulting in lower CO₂ emissions.</p>	 <p>The diagram illustrates the project scenario. It starts with 'Fossil fuel' (represented by a flame icon) which is used to generate 'Grid' electricity (represented by a lightning bolt icon). This 'Grid' electricity is then used to power a 'Chiller' (represented by a snowflake icon). An 'Upgrade' (represented by a gear icon) is applied to the chiller, resulting in lower 'GHG' emissions (represented by a flame icon) compared to the baseline. Additionally, 'Grid' electricity is also shown being used to produce 'CO2' emissions (represented by a flame icon).</p>

AM0061 Methodology for rehabilitation and/or energy efficiency improvement in existing power plants

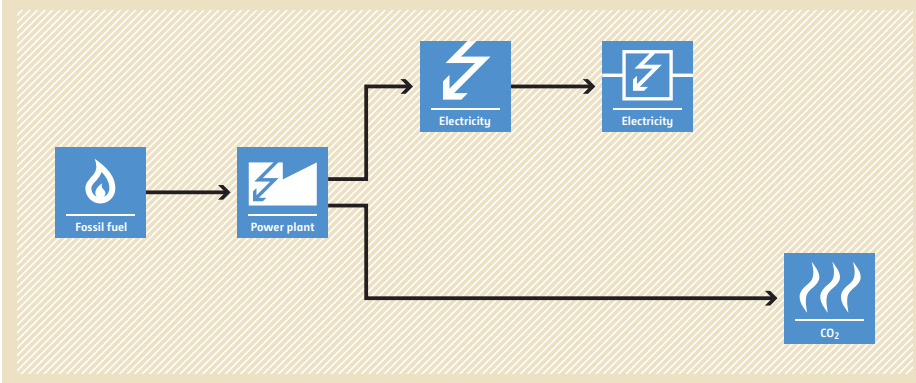
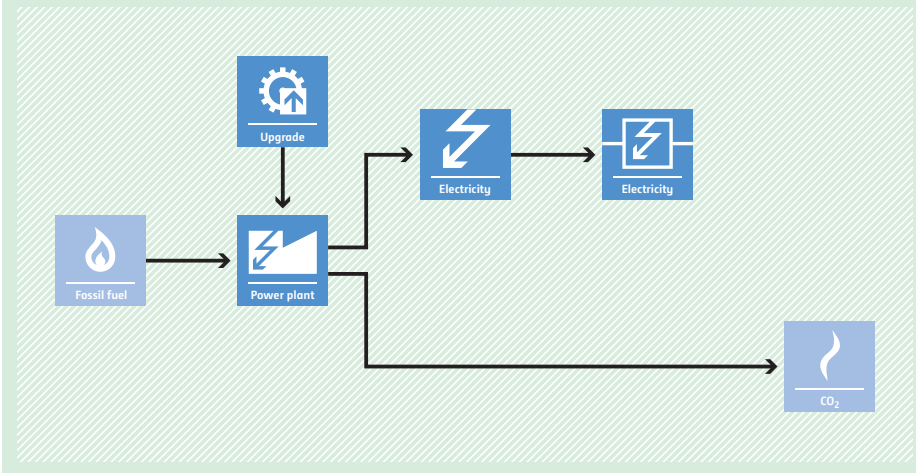
<p>Typical project(s)</p>	<p>Implementation of measures to increase the energy efficiency of existing power plants that supply electricity to the grid. Examples of these measures are: the replacement of worn blades of a turbine by new ones; the implementation of new control systems; replacement of deficient heat exchangers in a boiler by new ones, or the installation of additional heat recovery units in an existing boiler.</p>
<p>Type of GHG emissions mitigation action</p>	<ul style="list-style-type: none"> • Energy efficiency. <p>Technology switch resulting in an increase in energy efficiency in an existing power plant.</p>
<p>Important conditions under which the methodology is applicable</p>	<ul style="list-style-type: none"> • The project does not involve the installation and commissioning of new electricity generation units; • The designed power generation capacity of each unit may increase as a result of the project but this increase is limited to 15% of the former design power generation capacity of the whole plant; • The existing power plant has an operation history of at least 10 years and data on fuel consumption and electricity generation for the most recent five years prior to the implementation of the project are available; • Only measures that require capital investment can be included. Consequently, regular maintenance and housekeeping measures cannot be included in the project.
<p>Important parameters</p>	<p>Monitored:</p> <ul style="list-style-type: none"> • Energy efficiency of the project power plant; • Quantity of fuel used in the project power plant; • Calorific value and emission factor of the fuel used in the project power plant; • Electricity supplied to the grid by the project power plant.
<p>BASELINE SCENARIO Continuation of the operation of the power plant, using all power generation equipment already used prior to the implementation of the project, and undertaking business as usual maintenance.</p>	 <p>The diagram illustrates the baseline scenario. It starts with a 'Fossil fuel' icon (a flame) pointing to a 'Power plant' icon (a factory with a lightning bolt). From the power plant, two arrows branch out: one points to an 'Electricity' icon (a lightning bolt) and the other points to a 'CO2' icon (a flame with wavy lines). The 'Electricity' icon then points to a second 'Electricity' icon, representing the grid.</p>
<p>PROJECT SCENARIO Implementation of energy efficiency improvement measures or the rehabilitation of an existing fossil-fuel-fired power plant. As a result, less fossil fuel is consumed to generate electricity.</p>	 <p>The diagram illustrates the project scenario. It is similar to the baseline scenario but includes an 'Upgrade' icon (a gear with an upward arrow) pointing to the 'Power plant' icon. This indicates that the power plant has been improved. The flow of fossil fuel, electricity, and CO2 emissions remains the same as in the baseline scenario.</p>

AM0062 Energy efficiency improvements of a power plant through retrofitting turbines

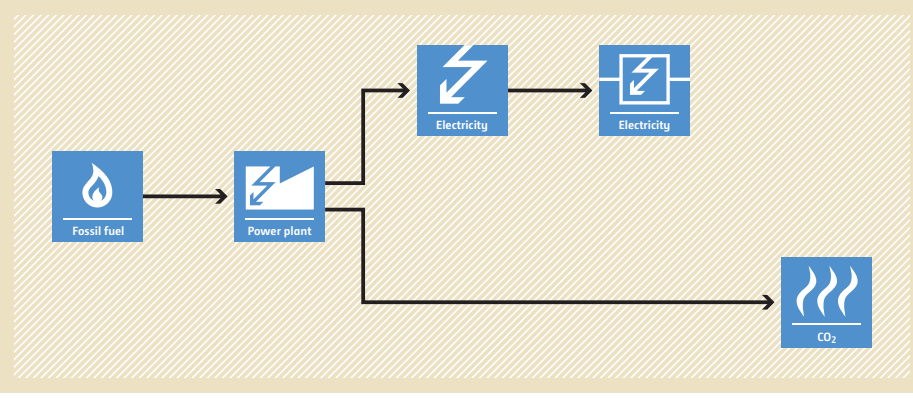
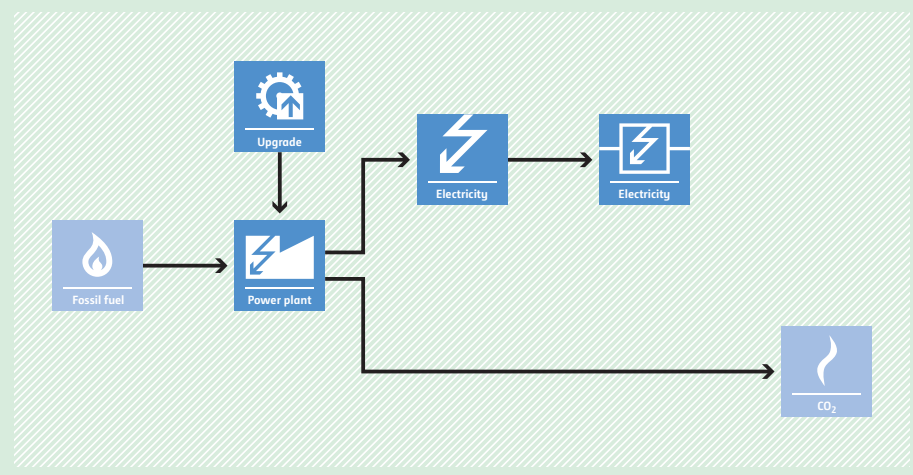
<p>Typical project(s)</p>	<p>Implementation of measures to increase the energy efficiency of steam or gas turbines in existing power plants that supply electricity to the grid. Examples of these measures are: replacement of worn blades of a turbine by new ones; implementation of refined sealing to reduce leakage; replacement of complete inner blocks (steam path, rotor, inner casing, inlet nozzles).</p>
<p>Type of GHG emissions mitigation action</p>	<ul style="list-style-type: none"> • Energy efficiency. <p>Technology switch resulting in an increase in energy efficiency at an existing power plant.</p>
<p>Important conditions under which the methodology is applicable</p>	<ul style="list-style-type: none"> • The project power plant utilizes fossil fuel to operate; • Measures related to recommended regular or preventive maintenance activities (including replacements and overhauling) as provided by the manufacturer of turbine, or superior practices of preventive maintenance (e.g. sophisticated cleaning systems resulting in improved efficiency) are not applicable; • The operational parameters that affect the energy efficiency of the turbine (e.g. steam pressure and temperature, quality of steam in the case of a saturated steam turbine; condenser vacuum, and combustion temperature for gas turbine) remain the same, subject to a variation of +/- 5%, in the baseline and the project scenario; • The methodology is applicable up to the end of the lifetime of the existing turbine, if shorter than the crediting period.
<p>Important parameters</p>	<p>Monitored:</p> <ul style="list-style-type: none"> • Quantity, calorific value and emission factor of fuel used in the project power plant; • Electricity supplied to the grid by the project power plant; • Enthalpy of the steam supplied to the turbine, in case of steam turbines.
<p>BASELINE SCENARIO Continuation of the current practice; i.e. the turbine continues to be operated without retrofitting.</p>	
<p>PROJECT SCENARIO Retrofitting of steam turbines and gas turbines with components of improved design to increase the energy efficiency in an existing fossil fuel power plant. Thus, fossil fuel consumption is reduced.</p>	

AM0063 Recovery of CO₂ from tail gas in industrial facilities to substitute the use of fossil fuels for production of CO₂

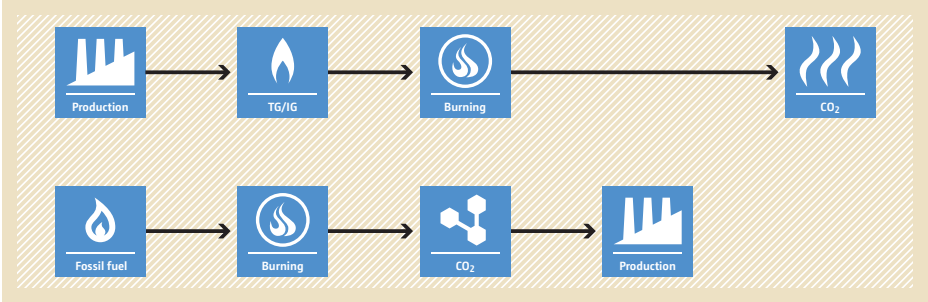
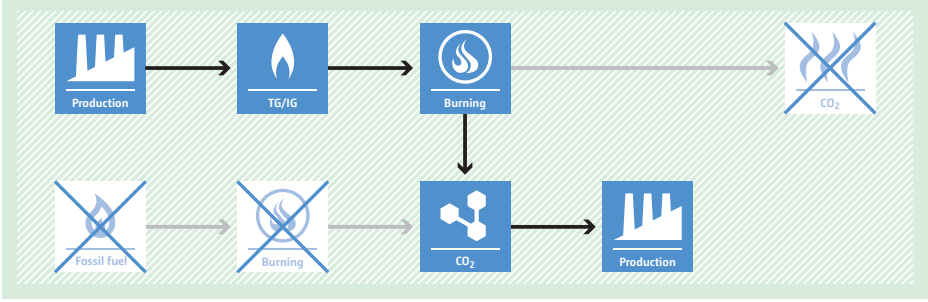
<p>Typical project(s)</p>	<p>Paragraph will include two parts, accordingly:</p> <ol style="list-style-type: none"> (1) Recovery of CO₂ from the tail gas (TG) generated by an existing industrial facility to substitute the combustion of fossil fuels at an existing conventional CO₂ production facility or a new CO₂ production plant; (2) Use of intermediate gas (IG) of a new production facility, for recovery of CO₂ in a new CO₂ production plant, established as part of the project activity.
<p>Type of GHG emissions mitigation action</p>	<ul style="list-style-type: none"> • Feedstock switch. <p>Displacement of more-GHG-intensive feedstock with CO₂ recovered from the tail gas or intermediate gas.</p>
<p>Important conditions under which the methodology is applicable</p>	<ul style="list-style-type: none"> • The tail gas from the existing industrial facility has been produced for as long as the industrial facility has been in operation; • There exist at least three years of historical records related to the operation of the industrial facility from which the tail gas is extracted; • Prior to the project implementation, the tail gas has either been used as fuel in the industrial facility without extraction of the CO₂ or has been flared; • The total amount of CO₂ produced at the project facility shall not be consumed at the project facility (e.g. for manufacturing of chemicals) and has to be sold within the host country; • The industrial facility does not utilize CO₂ in the intermediate gas for any other purpose in the production process.
<p>Important parameters</p>	<p>At validation:</p> <ul style="list-style-type: none"> • Quantity of CO₂ produced at the existing CO₂ production facility; • Electricity and fuel consumption at the existing CO₂ production facility. <hr/> <p>Monitored:</p> <ul style="list-style-type: none"> • Average carbon content and volume of the tail gas and/or intermediate gas delivered to the project CO₂ production facility; • Quantity of CO₂ produced at the project CO₂ production facility; • Average carbon content and volume of the off gas combusted at the industrial facility; • Amount and end use of CO₂ purchased by customers and date of delivery; • Quantity or volume of main product actually produced in year; • Quantity or volume of main product actually sold and delivered to customers.
<p>BASELINE SCENARIO Combustion of fossil fuel at a conventional CO₂ production facility.</p>	 <p>The diagram illustrates the baseline scenario in two rows. The top row shows a process flow: 'Production' (factory icon) → 'TG/IG' (flame icon) → 'Burning' (flame icon) → 'CO₂' (flame icon). The bottom row shows: 'Fossil fuel' (flame icon) → 'Burning' (flame icon) → 'CO₂' (molecule icon) → 'Production' (factory icon). The entire diagram is set against a light brown background with diagonal hatching.</p>
<p>PROJECT SCENARIO Recovery of CO₂ from the tail gas/intermediate gas generated by an existing industrial facility for use at the project CO₂ production facility.</p>	 <p>The diagram illustrates the project scenario in two rows. The top row shows: 'Production' (factory icon) → 'TG/IG' (flame icon) → 'Burning' (flame icon) → 'CO₂' (flame icon with a blue 'X' over it). The bottom row shows: 'Fossil fuel' (flame icon with a blue 'X' over it) → 'Burning' (flame icon with a blue 'X' over it) → 'CO₂' (molecule icon) → 'Production' (factory icon). A vertical arrow points from the 'Burning' step in the top row to the 'CO₂' step in the bottom row. The entire diagram is set against a light green background with diagonal hatching.</p>

AM0064 Capture and utilisation or destruction of mine methane (excluding coal mines) or non mine methane

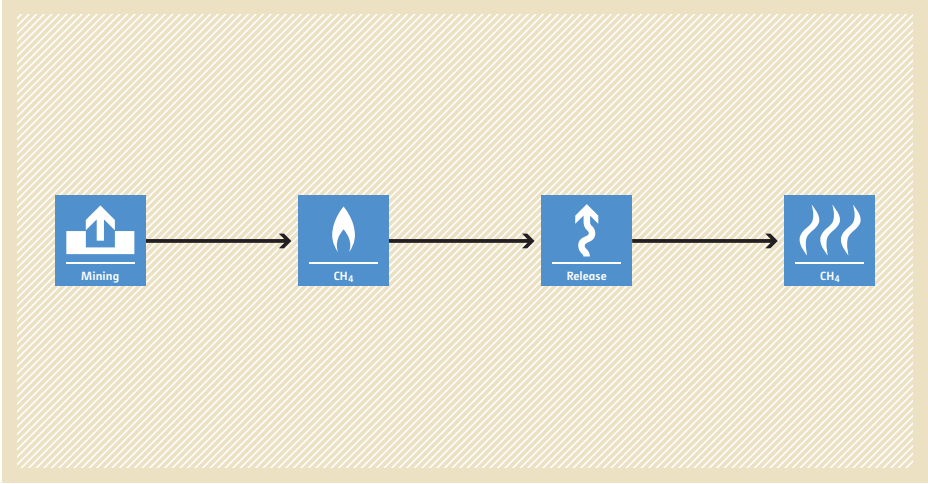
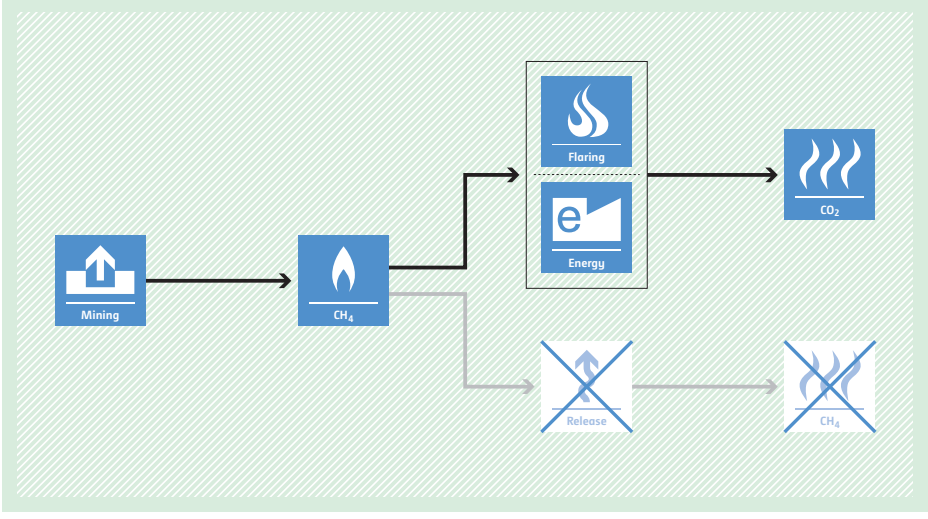
<p>Typical project(s)</p>	<p>Capture and utilization or destruction of methane from an operating mine, excluding mines where coal is extracted; capture and utilization or destruction of methane released from geological structures, e.g. methane released directly from holes drilled in geological formations specifically for mineral exploration and prospecting activities.</p>
<p>Type of GHG emissions mitigation action</p>	<ul style="list-style-type: none"> • GHG destruction. <p>Avoidance of GHG emissions from underground, hard rock, precious and base metal mines.</p>
<p>Important conditions under which the methodology is applicable</p>	<ul style="list-style-type: none"> • In case the project is capture and utilization or destruction of methane from an operating mine, the captured methane is utilized to produce electricity, motive power and/or thermal energy and/or destroyed through flaring. Prior to the start of the project all methane was released into the atmosphere or partially used for heat generation; • In case the project is capture and utilization or destruction of methane released from geological structures, abandoned or decommissioned mines, as well as open cast mines are excluded. Coal extraction mines or oil shale, as well as boreholes or wells opened for gas/oil exploration or extraction do not qualify; • Maximum outside diameter of the boreholes should not exceed 134 mm.
<p>Important parameters</p>	<p>Monitored:</p> <ul style="list-style-type: none"> • Concentration of methane in extracted gas; • Quantity of methane sent to power plant, boiler and gas grid for end users; • Quantity of electricity and heat generated by the project.
<p>BASELINE SCENARIO Methane is emitted from operating mines and geological structures into the atmosphere.</p>	 <p>The baseline scenario flowchart shows a linear process: Mining (represented by a blue icon of a mine) leads to CH₄ (represented by a blue icon of a flame), which then leads to Release (represented by a blue icon of an upward arrow), and finally to CH₄ (represented by a blue icon of flames) being emitted into the atmosphere.</p>
<p>PROJECT SCENARIO Methane is captured and destroyed or utilized for energy generation.</p>	 <p>The project scenario flowchart shows a branching process: Mining (represented by a blue icon of a mine) leads to CH₄ (represented by a blue icon of a flame). From this CH₄ node, two paths emerge: one leading to a box containing Flaring (flame icon) and Energy (e icon), which then leads to CO₂ (flame icon); the other path leading to a crossed-out Release (upward arrow icon) and CH₄ (flame icon) icon, indicating that these steps are avoided in the project scenario.</p>

AM0065 Replacement of SF₆ with alternate cover gas in the magnesium industry

<p>Typical project(s)</p>	<p>Full or partial replacement of the use of cover gas SF₆, an inert gas used to avoid oxidation of molten magnesium in casting and alloying processes, by alternate cover gas (HFC134a, Perfluoro-2-methyl-3-pentanone (CF₃CF₂C(O)CF(CF₃)₂) or SO₂ using lean SO₂ technology), in existing facilities of magnesium metal cast industry.</p>
<p>Type of GHG emissions mitigation action</p>	<ul style="list-style-type: none"> • GHG emission avoidance. <p>Avoidance of SF₆ emissions by the use of alternate cover gas.</p>
<p>Important conditions under which the methodology is applicable</p>	<ul style="list-style-type: none"> • Project of SF₆ replacement can be implemented in all segments of the magnesium metal cast industry, as defined in the methodology; • The magnesium metal cast facility has an operating history of at least three years prior to the project implementation; • If SO₂ is used as cover gas in the project, only “dilute SO₂” technology is used that meets the specifications provided in methodology; • Local regulations in the host country regarding SO₂ emissions in the exhausting system should be complied with. If such regulations are not in place, the values of SO₂ emissions given in the methodology should be complied with.
<p>Important parameters</p>	<p>At validation:</p> <ul style="list-style-type: none"> • Amount of magnesium manufactured in the most recent three years; • SF₆ consumption in the magnesium cast facility in the most recent three years prior to the project implementation. <p>Monitored:</p> <ul style="list-style-type: none"> • Amount of magnesium manufactured in the project; • Consumption of alternate cover gas in the project; • Consumption of SF₆ or CO₂ in the project, if any.
<p>BASELINE SCENARIO SF₆ continues to be used as cover gas in magnesium metal cast industry, leading to its emission from the processes.</p>	<p>The baseline scenario flowchart shows a linear process starting with SF₆ (represented by a molecule icon), followed by Magnesium production (factory icon), then SF₆ usage (factory icon), Release (upward arrow icon), and finally SF₆ emissions (flame icon).</p>
<p>PROJECT SCENARIO SF₆ is replaced with alternate cover gas, resulting in avoidance of SF₆ emissions.</p>	<p>The project scenario flowchart shows an 'Alternative' (molecule icon) and a crossed-out 'SF₆' (molecule icon) both feeding into 'Magnesium' (factory icon). From 'Magnesium', the path splits: one leads to 'GHG' (flame icon) and another to a crossed-out 'SF₆' (factory icon). This crossed-out 'SF₆' leads to a crossed-out 'Release' (upward arrow icon), which then leads to a crossed-out 'SF₆' (flame icon).</p>

AM0066 GHG emission reductions through waste heat utilisation for pre-heating of raw materials in sponge iron manufacturing process

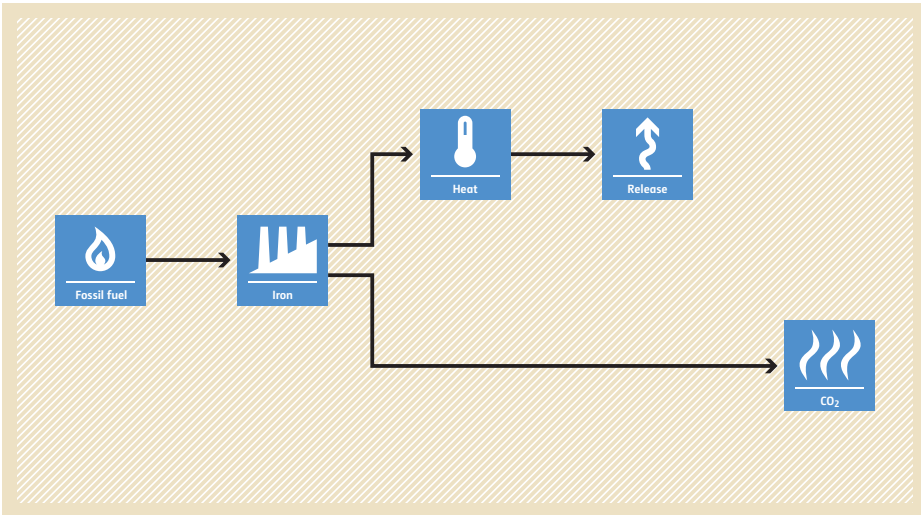
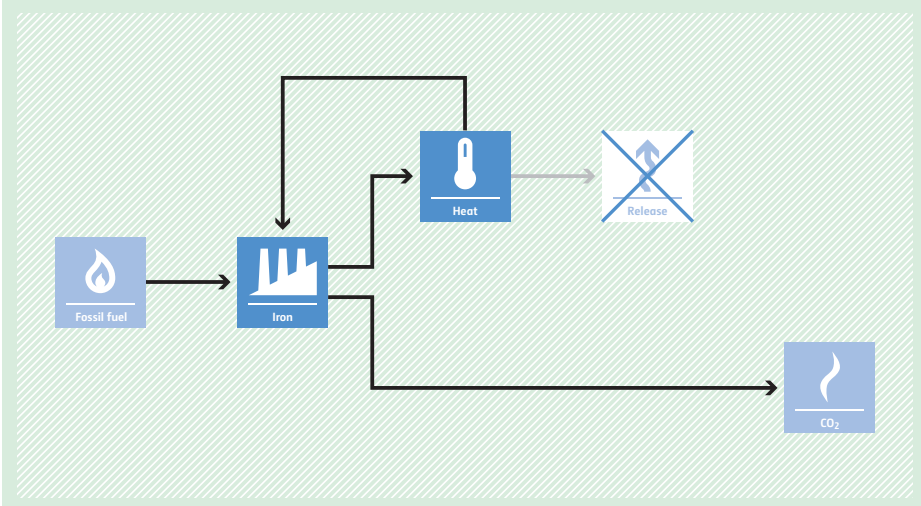
<p>Typical project(s)</p>	<p>Waste heat released from furnace(s)/kiln(s) is utilized to preheat raw material(s) in an existing or greenfield sponge iron manufacturing facility.</p>
<p>Type of GHG emissions mitigation action</p>	<ul style="list-style-type: none"> • Energy efficiency. <p>Energy efficiency improvement leading to reduced specific heat consumption.</p>
<p>Important conditions under which the methodology is applicable</p>	<ul style="list-style-type: none"> • The project is implemented either for an individual furnace/kiln or a group of furnaces/kilns producing the same type of output; • Waste heat to be utilized is generated in the project furnace(s)/kiln(s); • Only solid matter without scrap/product rejects is used as raw material; • In the project, the raw material is fed directly from the preheater to the furnace/kiln. However, the possibility to bypass the preheater equipment remains.
<p>Important parameters</p>	<p>At validation:</p> <ul style="list-style-type: none"> • Historical production and fossil fuel consumption.
	<p>Monitored:</p> <ul style="list-style-type: none"> • Quantity, chemical composition and physical state (including the percentage of the metallization) of raw materials and final product; • Type and quantities of fossil fuel; • Quantity of thermal and electrical (from the grid and from the captive power plant, respectively) energy consumed.
<p>BASELINE SCENARIO Fossil fuel is fired for the process. The resulting heat from furnace(s)/kiln(s) is not utilized and instead vented.</p>	 <p>The diagram shows a flow from 'Fossil fuel' to 'Iron' (represented by a factory icon). From the 'Iron' stage, an arrow points to a 'Heat' icon (thermometer), which then points to a 'Release' icon (upward arrow). A separate arrow from the 'Iron' stage points to a 'CO2' icon (flames).</p>
<p>PROJECT SCENARIO Less fossil fuel is fired in the process. The heat from furnace(s)/ kiln(s) is used to preheat raw material(s) before feeding it into the furnace(s)/kiln(s).</p>	 <p>The diagram shows a flow from 'Fossil fuel' to 'Iron' (represented by a factory icon). An arrow from the 'Iron' stage points to a 'Heat' icon (thermometer), which then loops back to the 'Iron' stage. A separate arrow from the 'Iron' stage points to a 'CO2' icon (flames). The 'Release' icon from the baseline scenario is crossed out with a blue 'X'.</p>

AM0067 Methodology for installation of energy efficient transformers in a power distribution grid

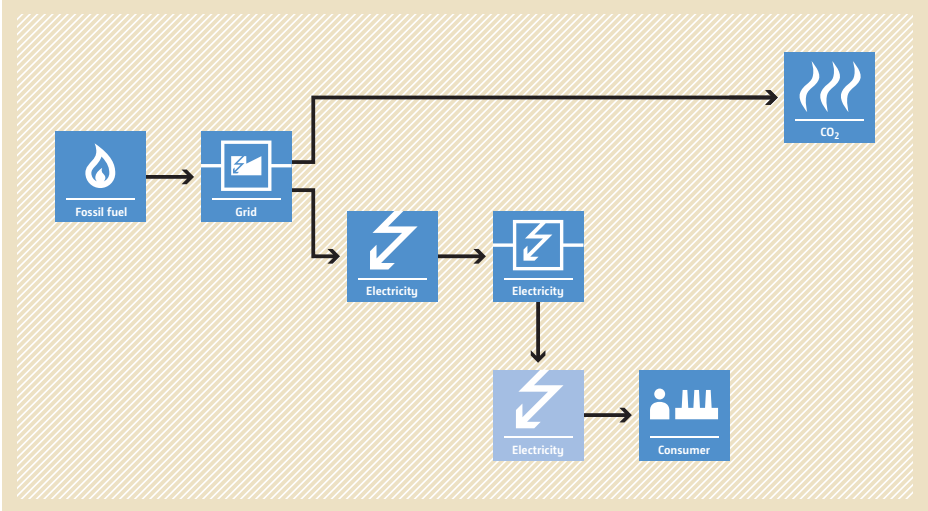
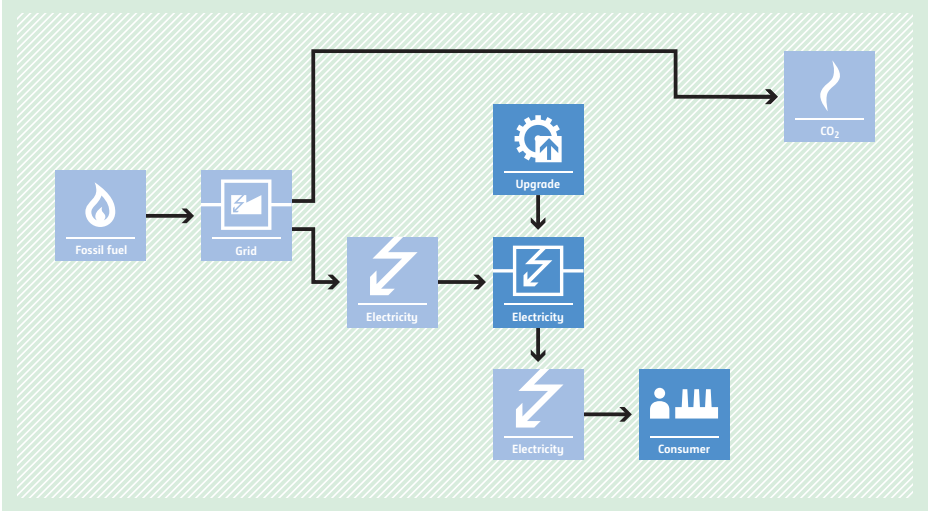
<p>Typical project(s)</p>	<p>Replacement of existing less-efficient transformers with more-efficient transformers in an existing distribution grid or the installation of new high-efficient transformers in new areas that are currently not connected to a distribution grid.</p>
<p>Type of GHG emissions mitigation action</p>	<ul style="list-style-type: none"> • Energy efficiency. <p>Implementation of high-efficient transformers reduces losses in the grid and thereby GHG emissions.</p>
<p>Important conditions under which the methodology is applicable</p>	<ul style="list-style-type: none"> • Emission reductions due to reduction in no-load losses alone are claimed; • Load losses, at rated load, of the transformers implemented under the project are demonstrated to be equal or lower than the load losses in transformers that would have been installed in absence of the project; • Project proponent implements a scrapping system to ensure that the replaced transformers are not used in other parts of the distribution grid or in another distribution grid.
<p>Important parameters</p>	<p>At validation:</p> <ul style="list-style-type: none"> • Average of no-load loss rate provided by the manufacturers of all type of transformers; • Grid emission factor (can also be monitored ex post). <p>Monitored:</p> <ul style="list-style-type: none"> • Cumulative number of transformers installed by the project as well as related load-loss rates and the black out rate.
<p>BASELINE SCENARIO Less-efficient transformers are installed in existing distribution grids or will be installed in new distribution grids.</p>	 <p>The diagram illustrates the baseline scenario. It starts with 'Fossil fuel' (represented by a flame icon) entering a 'Grid' (represented by a plug icon). From the grid, electricity flows through a series of three transformers (represented by lightning bolt icons). The grid itself is shown to emit 'CO2' (represented by a flame icon). The final transformer in the series feeds into a 'Consumer' (represented by a factory icon).</p>
<p>PROJECT SCENARIO High-efficient transformers are installed in existing distribution grids or will be installed in new distribution grids resulting in lower electricity generation requirements and thereby a reduction of GHG emissions.</p>	 <p>The diagram illustrates the project scenario. It follows the same flow as the baseline scenario: 'Fossil fuel' enters a 'Grid', which feeds into a series of three transformers, with the final one feeding into a 'Consumer'. However, an 'Upgrade' step (represented by a gear icon) is introduced between the first and second transformers. This upgrade results in a significantly smaller 'CO2' emission icon from the grid, indicating a reduction in GHG emissions compared to the baseline scenario.</p>

AM0068 Methodology for improved energy efficiency by modifying ferroalloy production facility

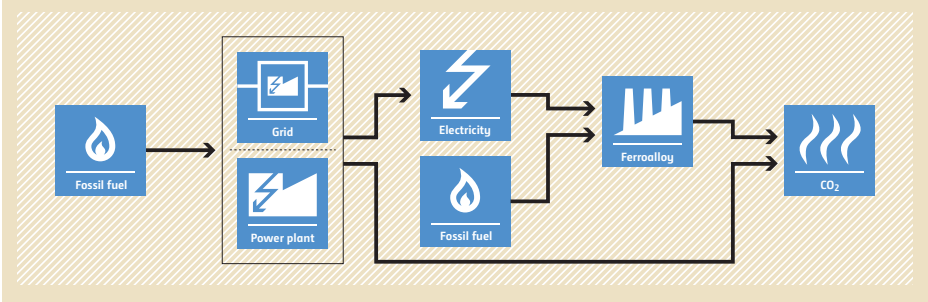
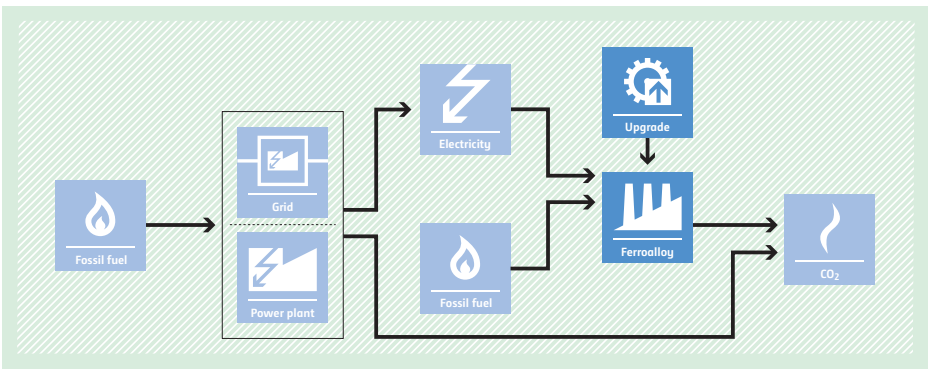
<p>Typical project(s)</p>	<p>The project is implemented to improve energy efficiency of an existing ferroalloy production facility. Improvement includes modification of existing submerged electric arc smelting furnace(s) into open slag bath smelting furnace(s) or modification of existing co-current rotary kilns into counter-current rotary kilns.</p> <p>The existing facility is limited to the submerged electric arc smelting furnace(s) and rotary kilns producing only one type of ferroalloy, as defined by the composition of its ingredients.</p>
<p>Type of GHG emissions mitigation action</p>	<ul style="list-style-type: none"> Energy efficiency. Switch to more-efficient technology.
<p>Important conditions under which the methodology is applicable</p>	<ul style="list-style-type: none"> The project includes at least the modification of “submerged bath electric furnaces” to “open slag bath melting furnaces” and can also include a modification of “co-current rotary kilns” to “counter-current rotary kilns”; Only one type of ferroalloy is produced at the facility and its type and quality is not affected by the project and remains unchanged throughout the crediting period; Data for at least the three years preceding the implementation of the project is available to estimate the baseline emissions.
<p>Important parameters</p>	<p>At validation:</p> <ul style="list-style-type: none"> Quantity and quality of ferroalloys produced; Consumption of electricity and fossil fuels in rotary kilns and smelting furnaces; Grid emission factor (can also be monitored ex post). <p>Monitored:</p> <ul style="list-style-type: none"> Quantity and quality of ferroalloy produced; Consumption of electricity and fossil fuels in rotary kilns and smelting furnaces; Non energy-related carbon streams (quantities and carbon content of reducing agents and its volatiles, ore, slag forming material, non product stream, etc.).
<p>BASELINE SCENARIO Energy (fossil fuel and electricity) is used in a ferroalloy production facility, leading to CO₂ emissions.</p>	 <p>The diagram illustrates the baseline energy flow. On the left, 'Fossil fuel' (flame icon) and 'Grid' (power lines icon) are inputs. 'Grid' and 'Power plant' (power lines icon) are grouped together. Arrows from 'Grid' and 'Power plant' lead to 'Electricity' (lightning bolt icon). An arrow from 'Fossil fuel' also leads to 'Electricity'. From 'Electricity', an arrow points to 'Ferroalloy' (factory icon). An arrow from 'Fossil fuel' also points to 'Ferroalloy'. Finally, an arrow from 'Ferroalloy' points to 'CO₂' (flame icon).</p>
<p>PROJECT SCENARIO Less energy (fossil fuel and electricity) is used in a ferroalloy production process, leading to lower CO₂ emissions.</p>	 <p>The diagram illustrates the project scenario energy flow. It is similar to the baseline scenario but includes an 'Upgrade' (gear icon) step. 'Fossil fuel' and 'Grid' are inputs. 'Grid' and 'Power plant' are grouped. Arrows from 'Grid' and 'Power plant' lead to 'Electricity'. An arrow from 'Fossil fuel' also leads to 'Electricity'. From 'Electricity', an arrow points to 'Upgrade'. An arrow from 'Upgrade' points to 'Ferroalloy'. An arrow from 'Fossil fuel' also points to 'Ferroalloy'. Finally, an arrow from 'Ferroalloy' points to 'CO₂'.</p>

AM0069 Biogenic methane use as feedstock and fuel for town gas production

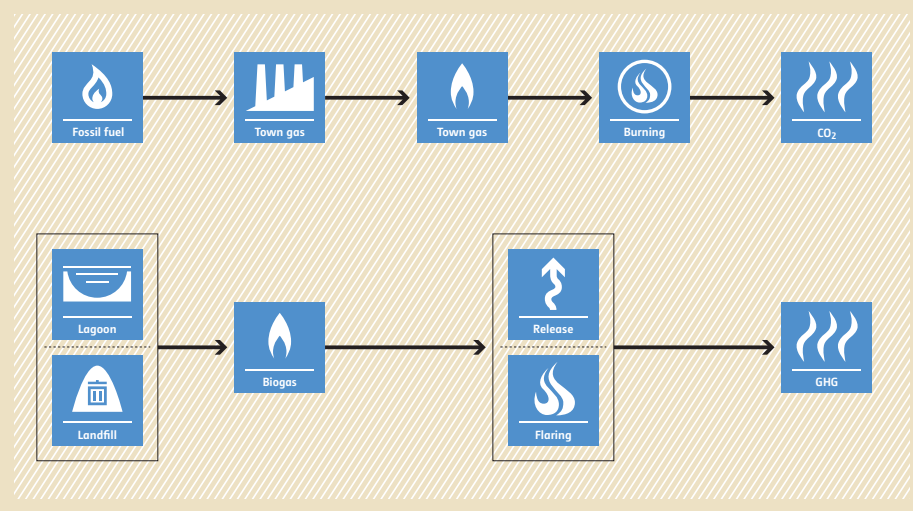
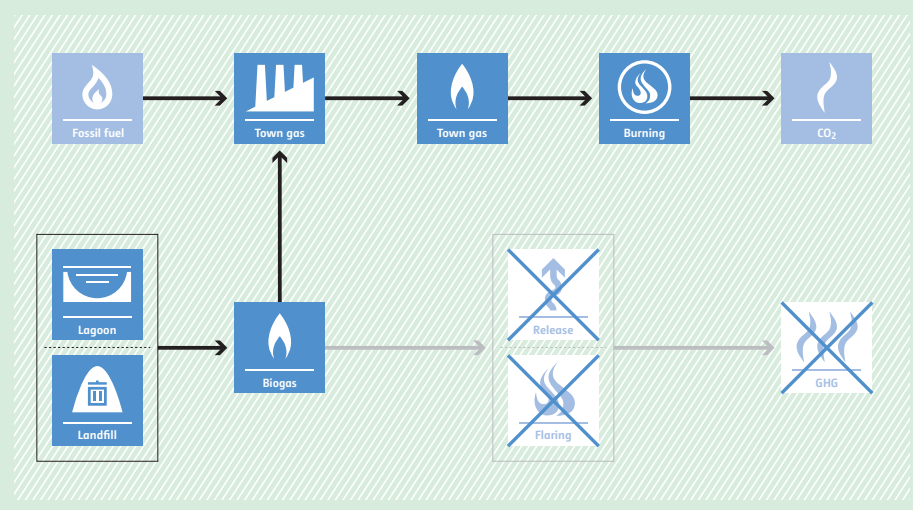
<p>Typical project(s)</p>	<p>Capture of biogas at a wastewater treatment facility or a landfill and use of the biogas to fully or partially substitute natural gas or other fossil fuels as feedstock and fuel for the production of town gas.</p>
<p>Type of GHG emissions mitigation action</p>	<ul style="list-style-type: none"> • GHG destruction; • Renewable energy; • Feedstock switch. <p>CH₄ emissions are avoided and fossil fuel is replaced.</p>
<p>Important conditions under which the methodology is applicable</p>	<ul style="list-style-type: none"> • There is no change in the quality of the produced town gas; • Town gas consumer and/ or distribution grid are within the host country boundaries; • Biogas is captured at an existing landfill site or wastewater treatment facility that has at least a three-year record of venting or flaring of biogas. Biogas would continue to be vented or flared in the absence of the project; • Project is implemented in an existing town gas factory that used only fossil fuels, no biogas, for at least three years prior to the start of the project.
<p>Important parameters</p>	<p>Monitored:</p> <ul style="list-style-type: none"> • Quantity and calorific value of town gas produced; • Quantity and calorific value of the biogas and fossil fuel used as feedstock.
<p>BASILINE SCENARIO Venting or flaring of biogas at the site where it is captured and use of fossil fuel as feedstock for town gas production.</p>	 <p>The baseline scenario flowchart is set against a light brown background. It shows two parallel processes. The top process starts with 'Fossil fuel' (flame icon), leading to 'Town gas' (factory icon), then another 'Town gas' (flame icon), then 'Burning' (flame in a circle icon), and finally 'CO₂' (flame icon). The bottom process starts with 'Lagoon' and 'Landfill' (wastewater and trash icons) leading to 'Biogas' (flame icon). From 'Biogas', the path splits into 'Release' (flame with upward arrow icon) and 'Flaring' (flame icon), both leading to 'GHG' (flame icon).</p>
<p>PROJECT SCENARIO Capture of biogas from landfills and/or waste treatment plants and use of it to replace fossil fuel.</p>	 <p>The project scenario flowchart is set against a light green background. It shows the same top process as the baseline: 'Fossil fuel' (flame icon) leads to 'Town gas' (factory icon), then another 'Town gas' (flame icon), then 'Burning' (flame in a circle icon), and finally 'CO₂' (flame icon). The bottom process starts with 'Lagoon' and 'Landfill' (wastewater and trash icons) leading to 'Biogas' (flame icon). An arrow points from 'Biogas' to the 'Town gas' factory icon, indicating it is used as feedstock. From 'Biogas', the paths to 'Release' (flame with upward arrow icon) and 'Flaring' (flame icon) are crossed out with blue 'X' marks, indicating these activities are avoided. The 'GHG' (flame icon) output is also crossed out with a blue 'X' mark.</p>

AM0070 Manufacturing of energy efficient domestic refrigerators



<p>Typical project(s)</p>	<p>Increase in the energy efficiency of manufactured refrigerators.</p>
<p>Type of GHG emissions mitigation action</p>	<ul style="list-style-type: none"> • Energy efficiency. <p>Increase in energy efficiency to reduce electricity consumed per unit of service provided.</p>
<p>Important conditions under which the methodology is applicable</p>	<ul style="list-style-type: none"> • Refrigerators are used by households on a continuous basis; • No increase in the GWP of refrigerants and foam blowing agents used; • No change in the general type of refrigerators; • If a labelling scheme is used to determine the rated electricity consumption of refrigerators, then it must cover 30% of the market share and include the most efficient refrigerators in the host country.
<p>Important parameters</p>	<p>At validation:</p> <ul style="list-style-type: none"> • Autonomous improvement ratio; • Information on historical sales (quantity, storage volumes, rated electricity consumption); • Grid emission factor (can also be monitored ex post). <p>Monitored:</p> <ul style="list-style-type: none"> • Quantity of refrigerators sold; • Specifications (model, design type and volume class) of refrigerators sold; • Electricity consumption of refrigerators in the monitoring sample group.
<p>BASILINE SCENARIO High electricity consumption by inefficient domestic refrigerators results in high CO₂ emissions from generation of electricity.</p>	<pre> graph LR FF[Fossil fuel] --> G[Grid] G --> E[Electricity] G --> CO2[CO2] E --> R[Refrigerators] R --> CO2 </pre>
<p>PROJECT SCENARIO Lower electricity consumption by more-efficient domestic refrigerators results in less CO₂ emissions from generation of electricity.</p>	<pre> graph LR FF[Fossil fuel] --> G[Grid] G --> E[Electricity] G --> CO2[CO2] E --> U[Upgrade] U --> R[Refrigerators] R --> CO2 </pre>

AM0071 Manufacturing and servicing of domestic and/or small commercial refrigeration appliances using a low GWP refrigerant



<p>Typical project(s)</p>	<p>Switching from a high GWP to low GWP refrigerant while manufacturing and refilling domestic and/or small commercial refrigeration appliances.</p>
<p>Type of GHG emissions mitigation action</p>	<ul style="list-style-type: none"> • Feedstock switch. <p>Avoidance of GHG emission by switching from high-GWP refrigerant to low-GWP refrigerant.</p>
<p>Important conditions under which the methodology is applicable</p>	<ul style="list-style-type: none"> • The manufacturer has been producing refrigeration appliances using HFC-134a for at least three years and has not been using low-GWP refrigerants prior to the start of the project; • Only one low-GWP refrigerant is used in manufacturing and refilling of refrigeration appliances; • The project does not lead to a decrease in energy efficiency; • Imported refrigeration appliances shall not be included in the project; • Less than 50% of the domestic refrigerant production use low GWP refrigerants.
<p>Important parameters</p>	<p>At validation:</p> <ul style="list-style-type: none"> • Historical production of refrigerators sold in host country with initial charge. <p>Monitored:</p> <ul style="list-style-type: none"> • Initial refrigerant charge in the project and its distribution losses; • Quantities and models of appliances manufactured and exported; • Number of reject units of refrigeration appliance model; • Failure rate involving refrigerant recharge.
<p>BASELINE SCENARIO Production of refrigeration appliances with high-GWP refrigerant.</p>	<pre> graph LR A[HFC Refrigerant] --> B[Refrigerators] B --> C[Refrigerators] B --> D[HFC] C --> E[HFC] </pre>
<p>PROJECT SCENARIO Production of refrigeration appliances with low-GWP refrigerant.</p>	<pre> graph LR A1[HFC Refrigerant] --> B[Refrigerators] A2[Refrigerant] --> B B --> C1[Refrigerators] B --> C2[Refrigerators] B --> D1[HFC] B --> D2[GHG] C1 --> E1[HFC] C2 --> E2[HFC] </pre>

AM0072 Fossil fuel displacement by geothermal resources for space heating

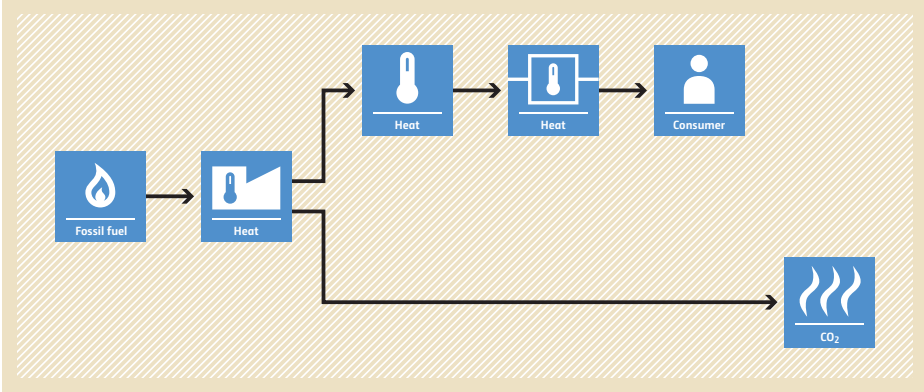
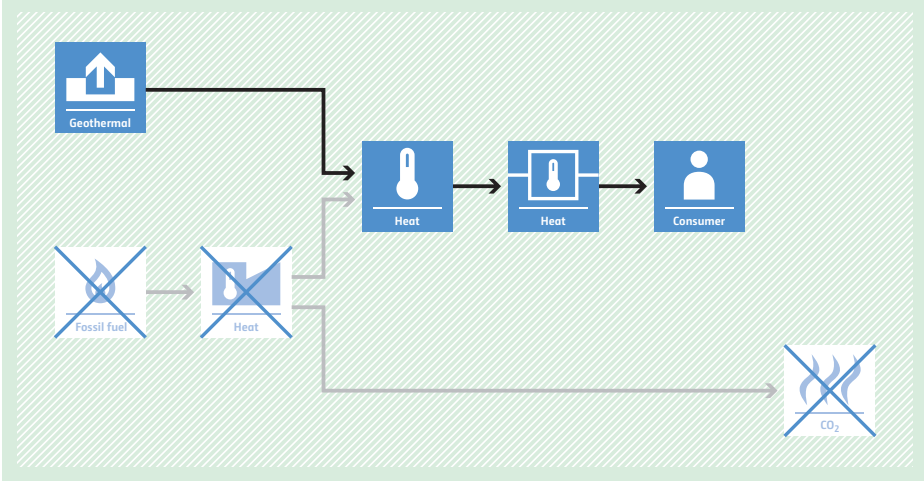
<p>Typical project(s)</p>	<p>Introduction of a centralized geothermal heat supply system for space heating in buildings. The geothermal heat supply system can be a new system in new buildings, the replacement of existing fossil fuel systems or the addition of extra geothermal wells to an existing system.</p>
<p>Type of GHG emissions mitigation action</p>	<ul style="list-style-type: none"> • Renewable energy. <p>Displacement of more-GHG-intensive thermal energy generation.</p>
<p>Important conditions under which the methodology is applicable</p>	<ul style="list-style-type: none"> • Use geothermal resources for centralized space-heating system in residential, commercial and/or industrial areas; • Use of GHG-emitting refrigerants is not permitted; • The heat drawn from the geothermal water replaces, partially or completely, the use of fossil fuel in the baseline situation whereas a maximum increase of the previous capacity of 10% is eligible (otherwise a new baseline scenario has to be developed).
<p>Important parameters</p>	<p>At validation:</p> <ul style="list-style-type: none"> • If applicable: three years of historical data for fossil fuel system, e.g. average thermal energy output or fuel consumption. <hr/> <p>Monitored:</p> <ul style="list-style-type: none"> • Temperature difference between inlet and outlet temperatures as well as flow rate at the downstream of the geothermal heat exchanger and the net heating area of the buildings included in the project boundary; • Geothermal non-condensable gas (CO₂ and CH₄) produced after the implementation of the project.
<p>BASELINE SCENARIO Fossil fuel is used as energy source for space heating</p>	 <p>The diagram illustrates the baseline scenario. It starts with a 'Fossil fuel' icon (flame) leading to a 'Heat' icon (thermometer). From this 'Heat' icon, two arrows branch out: one goes to a 'Heat' icon (thermometer) which then leads to a 'Consumer' icon (person), and the other goes directly to a 'CO₂' icon (flame with wavy lines).</p>
<p>PROJECT SCENARIO Installation of a new geothermal system in new building(s), replacement of existing fossil fuel heating systems or expansion of capacity of an existing geothermal system instead of using fossil fuel.</p>	 <p>The diagram illustrates the project scenario. It starts with a 'Geothermal' icon (house with upward arrow) leading to a 'Heat' icon (thermometer). From this 'Heat' icon, two arrows branch out: one goes to a 'Heat' icon (thermometer) which then leads to a 'Consumer' icon (person), and the other goes to a 'CO₂' icon (flame with wavy lines). The 'Fossil fuel' and 'Heat' icons from the baseline scenario are shown with a large 'X' over them, indicating they are no longer used.</p>

AM0073 GHG emission reductions through multi-site manure collection and treatment in a central plant

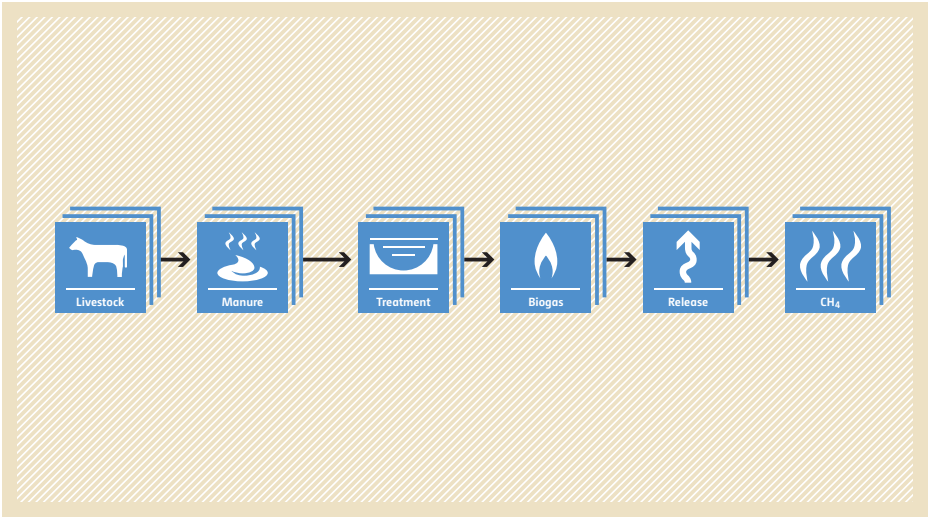
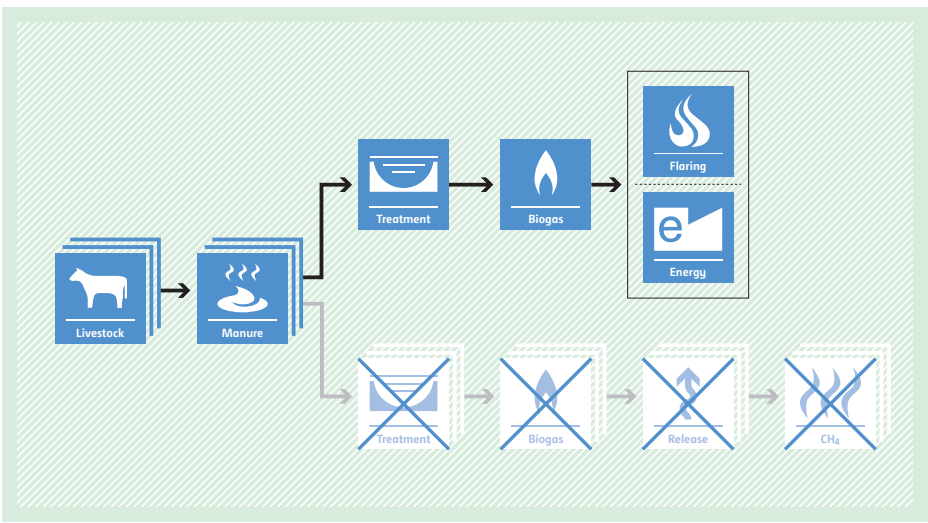
<p>Typical project(s)</p>	<p>Manure is collected by tank trucks, canalized and/or pumped from multiple livestock farms and then treated in a single central treatment plant.</p>
<p>Type of GHG emissions mitigation action</p>	<ul style="list-style-type: none"> • GHG destruction. • Release of CH₄ emissions is avoided by combustion of methane.
<p>Important conditions under which the methodology is applicable</p>	<ul style="list-style-type: none"> • Livestock farm populations are managed under confined conditions; • Manure is not discharged into natural water resources (e.g. rivers or estuaries); • Animal residues are treated under anaerobic conditions in the baseline situation (conditions for this treatment process are specified); • If treated residue is used as fertilizer in the baseline, then this end use continues under the project; • Sludge produced during the project is stabilized through thermal drying or composting, prior to its final disposition/application.
<p>Important parameters</p>	<p>Monitored:</p> <ul style="list-style-type: none"> • Volume, volatile solids and total nitrogen of the effluent and residues being treated or produced at the central treatment plant; • Auxiliary energy used to run project treatment steps; • Electricity or heat generated by the use of biogas.
<p>BASELINE SCENARIO Anaerobic manure treatment systems without methane recovery result in CH₄ emissions.</p>	 <p>The diagram illustrates the baseline scenario as a linear sequence of six steps: 1. Livestock (represented by a cow icon), 2. Manure (represented by a pile of manure icon), 3. Treatment (represented by a tank icon), 4. Biogas (represented by a flame icon), 5. Release (represented by an upward arrow icon), and 6. CH₄ (represented by a flame icon). Arrows connect each step to the next in a horizontal line.</p>
<p>PROJECT SCENARIO Manure from farms is collected and processes in a central treatment plant. Methane is captured and flared or used. In case of energetic use of biogas, displacement of more-GHG-intensive energy generation.</p>	 <p>The diagram illustrates the project scenario. It starts with Livestock and Manure, which lead to Treatment. From Treatment, Biogas is produced. This Biogas is then used for either Flaring (represented by a flame icon) or Energy (represented by an 'e' icon). The subsequent steps in the baseline scenario—Release and CH₄—are shown as crossed-out boxes, indicating they are avoided in the project scenario.</p>

AM0074 New grid connected power plants using permeate gas previously flared and/or vented

<p>Typical project(s)</p>	<p>Construction and operation of a power plant that supplies electricity to the grid and uses permeate gas, low heating value off-gas resultant from the processing of natural gas, as fuel to operate the power plant.</p>
<p>Type of GHG emissions mitigation action</p>	<ul style="list-style-type: none"> • Low carbon electricity. • Displacement of electricity that would be provided by more-carbon-intensive means.
<p>Important conditions under which the methodology is applicable</p>	<ul style="list-style-type: none"> • The total amount of permeate gas from the gas processing facility was flared and/or vented for at least three years prior to the start of the project; • The transportation of the permeate gas from the natural gas processing facility to the new power plant occurs through a dedicated pipeline that is established as part of the project and not used for the transportation of any other gases; • All power produced by the project power plant is exported to the grid.
<p>Important parameters</p>	<p>At validation:</p> <ul style="list-style-type: none"> • Fugitive CH₄ emission factor of all relevant equipment types used to transport the permeate gas; • Low heating value of permeate gas; • Annual average quantity of permeate gas flared and/or vented in three years prior to the start of the project activity. <p>Monitored:</p> <ul style="list-style-type: none"> • Electricity supplied to the grid by the project power plant; • Average mass fraction of methane in the permeate gas; • Operation time of equipment used to transport the permeate gas; • Baseline emission factor for project electricity system; • Quantity of permeate gas used for electricity generation.

BASELINE SCENARIO
Permeate gas is flared and/or vented. Electricity is generated using processed natural gas or other energy sources than permeate gas, or electricity is provided by the grid.

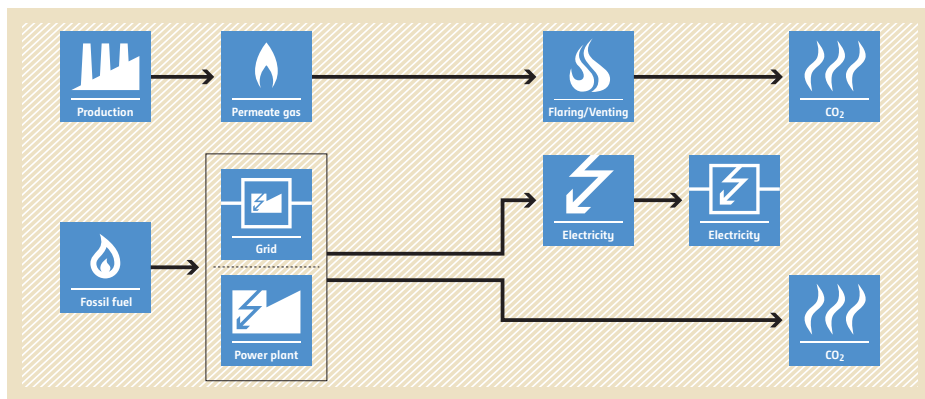

PROJECT SCENARIO
Permeate gas, previously flared and/or vented at the existing natural gas processing facility, is used as fuel in a new grid-connected power plant.

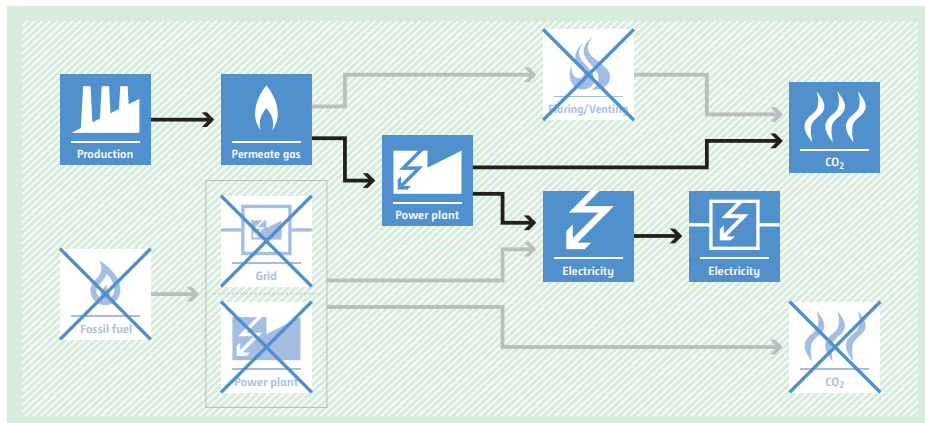

AM0075 Methodology for collection, processing and supply of biogas to end-users for production of heat

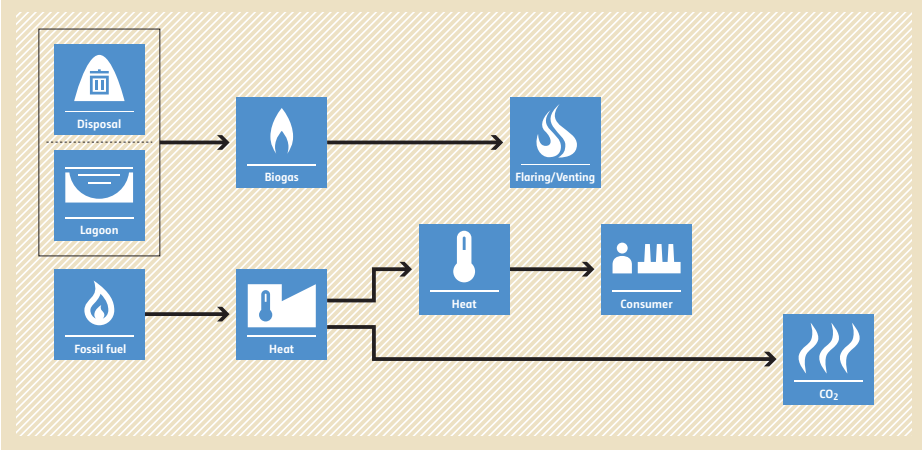
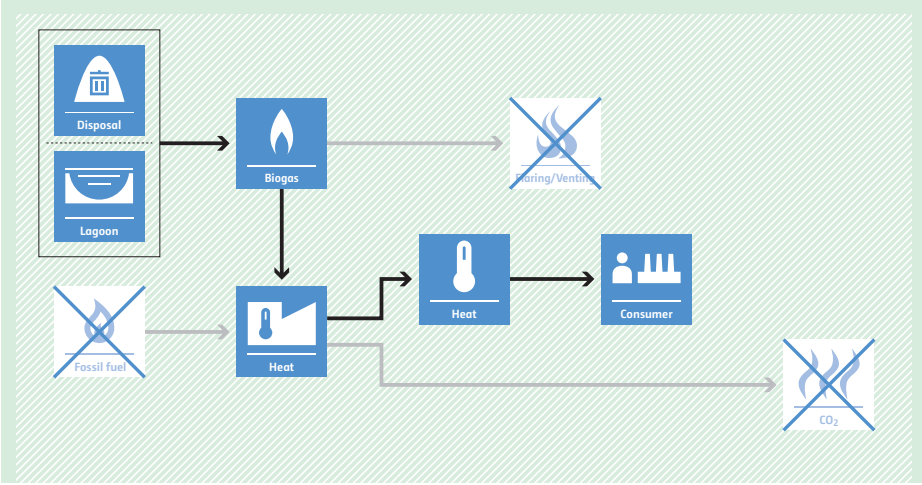
<p>Typical project(s)</p>	<p>Processing and upgrading the biogas collected from biogas producing site(s) in a new biogas processing facility and supplying it to existing end-user(s) to produce heat in heat generation equipments for on-site use.</p>
<p>Type of GHG emissions mitigation action</p>	<ul style="list-style-type: none"> • GHG destruction; • Renewable energy. <p>Switching from more-carbon-intensive fuel to biogas that was previously flared or vented.</p>
<p>Important conditions under which the methodology is applicable</p>	<ul style="list-style-type: none"> • The biogas is obtained from one or several existing biogas producing site(s) that have to be identified ex ante; • The biogas was either vented or flared prior to implementation of the project; • All heat generation equipments included in the project have to be identified ex ante, and it has to be demonstrated that these were using only fossil fuel prior to implementation of the project; • Any transportation of biogas or processed biogas occurs only through dedicated pipelines or by road vehicles.
<p>Important parameters</p>	<p>Monitored:</p> <ul style="list-style-type: none"> • Amount and net calorific value of processed biogas supplied to the boiler or heat generation equipment(s); • Amount of the steam or heat produced in the boiler or heat generation equipment(s); • Amount and net calorific value of fossil fuel used in the boiler or heat generation equipment.
<p>BASELINE SCENARIO Use of fossil fuel in heat generation equipments and biogas is flared or vented.</p>	 <p>The diagram illustrates the baseline scenario. On the left, 'Disposal' and 'Lagoon' are grouped in a box and lead to 'Biogas'. 'Biogas' has two paths: one to 'Flaring/Venting' and another to 'Heat'. 'Fossil fuel' also leads to 'Heat'. The 'Heat' from both 'Biogas' and 'Fossil fuel' is then sent to a 'Consumer' (represented by a factory icon), which finally leads to 'CO2' emissions (represented by a flame icon).</p>
<p>PROJECT SCENARIO Upgraded biogas burned in the heat generation equipments avoiding the use of fossil fuel.</p>	 <p>The diagram illustrates the project scenario. On the left, 'Disposal' and 'Lagoon' are grouped in a box and lead to 'Biogas'. 'Biogas' goes to 'Heat', which then goes to a 'Consumer' (represented by a factory icon), which finally leads to 'CO2' emissions (represented by a flame icon). 'Fossil fuel' and 'Flaring/Venting' are crossed out with red X's, indicating they are avoided in this scenario.</p>

AM0076 Methodology for implementation of fossil fuel trigeneration systems in existing industrial facilities

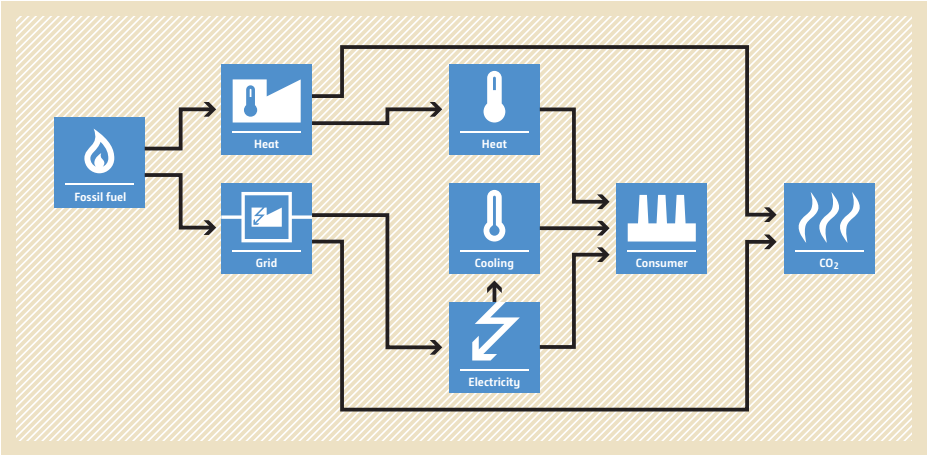
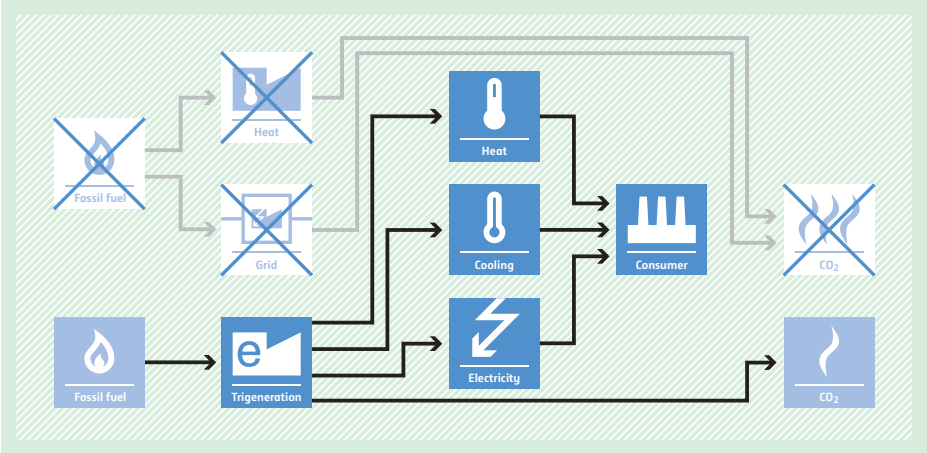
<p>Typical project(s)</p>	<p>Installation of an on-site fossil-fuel-based trigeneration plant to supply electricity, steam and chilled water to an industrial facility.</p>
<p>Type of GHG emissions mitigation action</p>	<ul style="list-style-type: none"> • Energy efficiency. <p>Displacement of electricity, heat and cooling that would be provided by more-carbon-intensive means.</p>
<p>Important conditions under which the methodology is applicable</p>	<ul style="list-style-type: none"> • The baseline is the separate supply of electricity from the grid, heat supplied by an on-site fossil fuel fired boiler and chilled water from on-site electrical compression chillers; • There have been no cogeneration (CHP) or trigeneration (CCHP) systems operating in the industrial facility prior to the project; • No steam or chilled water is exported in the project; • Chillers in the project are heat driven (absorption chillers).
<p>Important parameters</p>	<p>At validation:</p> <ul style="list-style-type: none"> • Output efficiency of the baseline boiler; • Power consumption function of the baseline chiller. <hr/> <p>Monitored:</p> <ul style="list-style-type: none"> • Electricity produced/purchased/sold by the trigeneration plant; • Quantity of fuels used in the trigeneration plant; • Quantity, temperature and pressure of steam produced by the trigeneration plant; • Quantity and temperature of chilled water produced by the trigeneration plant.
<p>BASELINE SCENARIO Separate supply of electricity from the grid, chilled water using grid electricity and steam by a fossil-fuel-fired boiler.</p>	 <p>The diagram illustrates the baseline scenario. On the left, 'Fossil fuel' (flame icon) feeds into a 'Heat' (thermometer icon) box. Below it, 'Grid' (power plug icon) feeds into a 'Cooling' (thermometer icon) box. The 'Cooling' box also receives input from 'Electricity' (lightning bolt icon). The 'Heat' box feeds into a 'Consumer' (factory icon), which also receives input from the 'Cooling' box. The 'Electricity' box feeds into the 'Consumer'. Finally, the 'Consumer' outputs 'CO2' (flame icon).</p>
<p>PROJECT SCENARIO A fossil fuel-fired trigeneration plant generates directly at the industrial facility electricity, steam and chilled water resulting in overall lower CO₂ emissions.</p>	 <p>The diagram illustrates the project scenario. On the left, 'Fossil fuel' (flame icon) feeds into a 'Trigeneration' (e icon) box. The 'Trigeneration' box outputs to three boxes: 'Heat' (thermometer icon), 'Cooling' (thermometer icon), and 'Electricity' (lightning bolt icon). The 'Heat' box feeds into a 'Consumer' (factory icon), which also receives input from the 'Cooling' box. The 'Electricity' box feeds into the 'Consumer'. Finally, the 'Consumer' outputs 'CO2' (flame icon). In this scenario, the 'Fossil fuel', 'Heat', 'Grid', and 'Cooling' boxes from the baseline are crossed out with a large 'X'.</p>

AM0077 Recovery of gas from oil wells that would otherwise be vented or flared and its delivery to specific end-users

<p>Typical project(s)</p>	<p>Associated gas from oil wells that was previously flared or vented, is recovered and processed in a new gas processing plant along with, optionally, non-associated gas. The processed gas is delivered to clearly identifiable specific end-user(s) by means of CNG mobile units and/or delivered into an existing natural gas pipeline.</p>
<p>Type of GHG emissions mitigation action</p>	<ul style="list-style-type: none"> • Fuel switch; <p>Recovery of associated gas from oil wells that would otherwise be flared or vented for displacement of non-associated gas in a new gas processing plant.</p>
<p>Important conditions under which the methodology is applicable</p>	<ul style="list-style-type: none"> • The recovered gas comes from oil wells that are in operation and producing oil at the time. Records of flaring or venting of the associated gas are available for at least three years; • The processed gas is consumed in the host country(ies) only; • If the project oil wells include gas-lift systems, the gas-lift gas has to be associated gas from the oil wells within the project boundary; • The natural gas can be used only in heat generating equipment.
<p>Important parameters</p>	<p>Monitored:</p> <ul style="list-style-type: none"> • Quantity and carbon content of gas measured at various points, i.e. recovered associated gas, non-associated gas from natural gas wells, gas or other fossil fuel consumed on site, gas delivered to end-user(s), gas delivered to natural gas pipeline; • If applicable: quantity and net calorific value of fuel consumed in vehicles for transportation of CNG.
<p>BASELINE SCENARIO Associated gas from oil wells is flared or vented and end users meet their energy demand using other fossil fuel.</p>	
<p>PROJECT SCENARIO Associated gas from oil wells is recovered instead of flared or vented and displaces the use of other fossil fuel by the end-users.</p>	

AM0078 Point of use abatement device to reduce SF₆ emissions in LCD manufacturing operations

<p>Typical project(s)</p>	<p>Installation of a combustion or thermal abatement device to destroy SF₆ emissions from an LCD etching plant.</p>
<p>Type of GHG emissions mitigation action</p>	<ul style="list-style-type: none"> • GHG destruction. • Combustion or thermal destruction of SF₆ emissions.
<p>Important conditions under which the methodology is applicable</p>	<ul style="list-style-type: none"> • Production lines with at least three years of information about SF₆ purchase and consumption and production of LCD substrate by January 31, 2009; • There is no local law or regulation that mandates decomposition, destruction, recycling or substitution of SF₆ or any component of exhaust gases containing SF₆; • The SF₆ destruction should occur at the same industrial site where SF₆ is used, and the SF₆ destroyed is not imported from other facilities.
<p>Important parameters</p>	<p>At validation:</p> <ul style="list-style-type: none"> • SF₆ consumption in the most recent three years; • Production of LCD substrate in the most recent three years. <p>Monitored:</p> <ul style="list-style-type: none"> • Mass of SF₆ gas entering and existing the abatement device; • SF₆ consumption in the project; • Production of LCD substrate; • Electricity and/or fuel consumption for the operation of the abatement device.
<p>BASELINE SCENARIO SF₆ is released to the atmosphere after being used in the etching of LCD units.</p>	<p>The baseline scenario flowchart shows a linear process: SF₆ gas is used in LCD manufacturing, then released to the atmosphere. The icons are: SF₆ (hexagonal molecule), LCD (factory), SF₆ (hexagonal molecule), Release (upward arrow), and SF₆ (hexagonal molecule).</p>
<p>PROJECT SCENARIO SF₆ is recovered and destroyed in an abatement unit located after the etching unit.</p>	<p>The project scenario flowchart shows SF₆ gas used in LCD manufacturing, then entering an abatement unit. The abatement unit uses fossil fuel and electricity for decomposition, resulting in CO₂ emissions. A crossed-out path indicates that SF₆ is not released to the atmosphere. The icons are: SF₆ (hexagonal molecule), LCD (factory), SF₆ (hexagonal molecule), Abatement unit (Fossil fuel and Electricity icons), Decomposition (flame icon), CO₂ (flame icon), and a crossed-out SF₆ (hexagonal molecule) icon.</p>

AM0079 Recovery of SF₆ from gas insulated electrical equipment in testing facilities

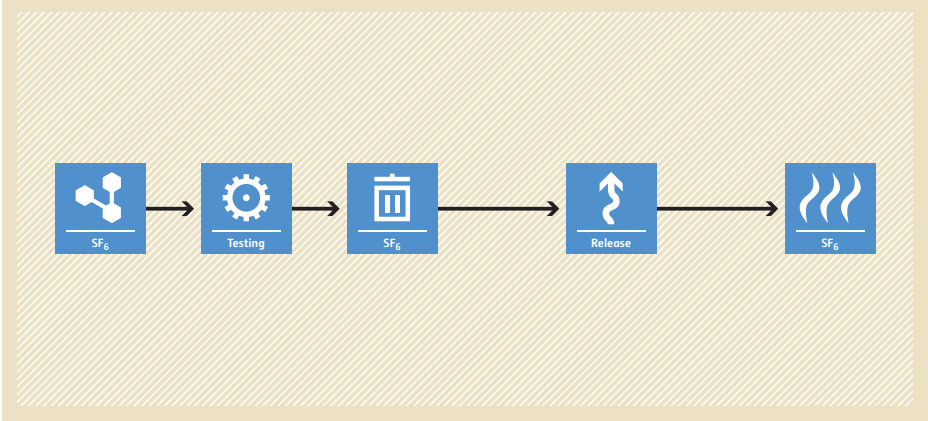
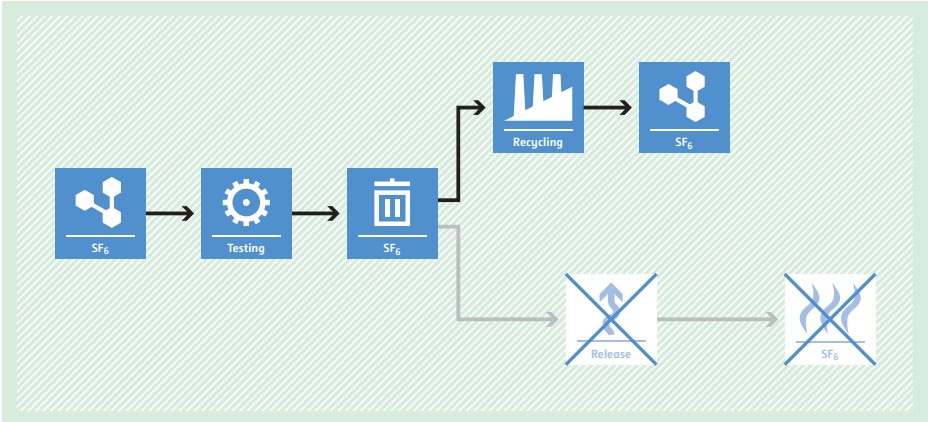
<p>Typical project(s)</p>	<p>Installation of a recovery system for used SF₆ gas that would be vented after the testing of gas-insulated electrical equipment at a testing facility, and then reclamation of the recovered SF₆ gas at an SF₆ production facility.</p>
<p>Type of GHG emissions mitigation action</p>	<ul style="list-style-type: none"> • GHG formation avoidance. <p>Avoidance of SF₆ emissions by recovery and reclamation of the SF₆ emissions.</p>
<p>Important conditions under which the methodology is applicable</p>	<ul style="list-style-type: none"> • The SF₆ recovery site uses SF₆ in the testing of gas-insulated electrical equipment, which are performed as part of a rating process, or during development or production of new electrical equipment; • The recovered gas is reclaimed by using it as a feedstock in the production of new SF₆ on the premises of an existing SF₆ production facility; • The testing considered for the project is electrical tests of medium and high voltage rated equipment (>1 kV); • Before the project implementation, SF₆ gas used in the equipment for the tests is vented after testing.
<p>Important parameters</p>	<p>At validation:</p> <ul style="list-style-type: none"> • Mass of SF₆ that is vented during testing for at least one year of historical data; • Concentration of SF₆ in a recovery cylinder for at least one year of historical data. <hr/> <p>Monitored:</p> <ul style="list-style-type: none"> • Mass of SF₆ that is filled into each gas-insulated electrical equipment; • Mass of SF₆ recovered at the recovery site and used as feedstock at the reclamation site; • Concentration of SF₆ in a recovery cylinder.
<p>BASELINE SCENARIO SF₆ is released to the atmosphere after the completion of the test of a gas-insulated electrical equipment.</p>	 <p>The diagram illustrates the baseline scenario. It starts with a box labeled 'SF₆' containing a molecular structure icon. An arrow points to a 'Testing' box with a gear icon. Another arrow points to an 'SF₆' box with a storage tank icon. A third arrow points to a 'Release' box with an upward arrow icon. A final arrow points to an 'SF₆' box with a flame icon, representing atmospheric release.</p>
<p>PROJECT SCENARIO SF₆ used during the test is recovered and transported to a reclamation facility where the recovered gas will be re-injected in the stream to produce new SF₆.</p>	 <p>The diagram illustrates the project scenario. It starts with a box labeled 'SF₆' containing a molecular structure icon. An arrow points to a 'Testing' box with a gear icon. Another arrow points to an 'SF₆' box with a storage tank icon. From this box, two arrows branch out: one points to a 'Recycling' box with a factory icon, which then points to a new 'SF₆' box with a molecular structure icon; the other points to a 'Release' box with an upward arrow icon that has a large 'X' over it. A final arrow points to an 'SF₆' box with a flame icon that also has a large 'X' over it, indicating that release is avoided.</p>

AM0080 Mitigation of greenhouse gases emissions with treatment of wastewater in aerobic wastewater treatment plants

Typical project(s)	Implementing a new aerobic wastewater treatment plant for the treatment of domestic and/or industrial wastewater, with sludge treated either in the same manner as the baseline, or in a new anaerobic digester with biogas capture. The biogas is either flared and/or used to generate electricity and/or heat.
Type of GHG emissions mitigation action	<ul style="list-style-type: none"> • GHG emission avoidance. Avoidance of CH ₄ emissions from wastewater treatment.
Important conditions under which the methodology is applicable	<ul style="list-style-type: none"> • The project either replaces an existing anaerobic open lagoon system, with or without conversion of the sludge treatment system, or is an alternative to a new to be built anaerobic open lagoon system; • Loading in the wastewater streams has to be high enough to ensure that algal oxygen production can be ruled out in the baseline; • The average depth of the existing or new to be built anaerobic open lagoons system is at least one metre and residence time of the organic matter is at least 30 days.
Important parameters	Monitored: <ul style="list-style-type: none"> • Quantity and average chemical oxygen demand of the wastewater that is treated; • Electricity and heat generated with biogas from the new anaerobic digester, if applicable; • Quantity of produced sludge; • Fossil fuel, electricity and transportation needed to operate the project.

BASELINE SCENARIO

Wastewater would have been treated in an anaerobic open lagoon system without methane recovery and flaring. Sludge would have been dumped or left to decay, or dried under controlled and aerobic conditions and then disposed to a landfill with methane recovery or used in soil application.

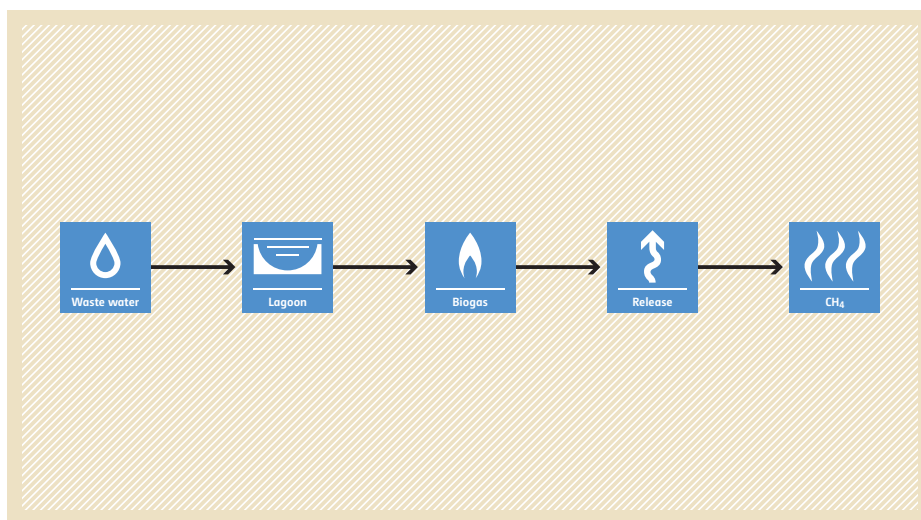

PROJECT SCENARIO

Installation of a new aerobic wastewater treatment plant. Sludge is treated either the same way as the baseline or in a new anaerobic digester with the biogas capture.

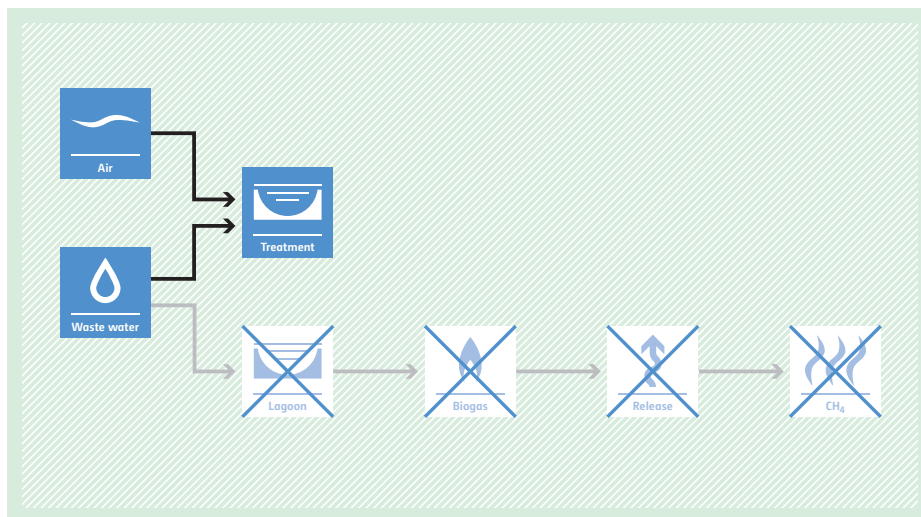

AM0081 Flare or vent reduction at coke plants through the conversion of their waste gas into dimethyl ether for use as a fuel

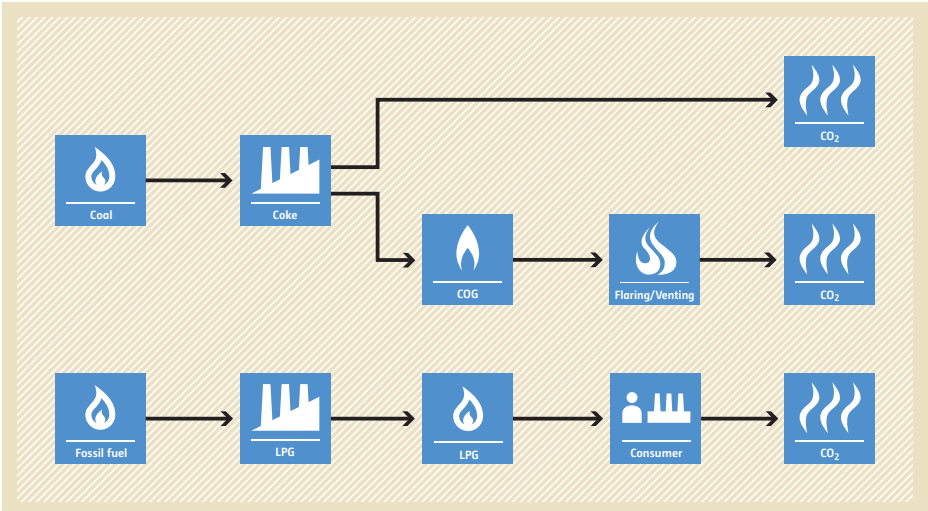
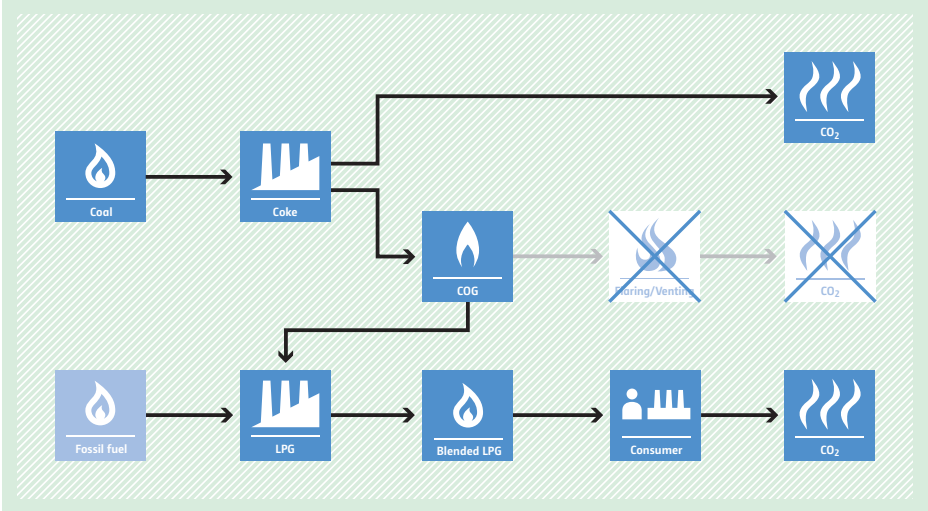
<p>Typical project(s)</p>	<p>Construction of a new dimethyl ether (DME) facility to utilize a previously vented or flared stream of Coke Oven Gas (COG).</p>
<p>Type of GHG emissions mitigation action</p>	<ul style="list-style-type: none"> • Fuel switch. <p>Use of a previously vented source of carbon for the production of DME and use of DME for LPG blending.</p>
<p>Important conditions under which the methodology is applicable</p>	<ul style="list-style-type: none"> • The project is a newly built DME plant which will supply DME to LPG processing facilities for blending purposes; • The history of the coke plant is the venting or flaring of COG for at least three years; • Bituminous coal remains the sole coking coal for the coke plant; • COG is the only carbon source used for DME production.
<p>Important parameters</p>	<p>At validation:</p> <ul style="list-style-type: none"> • Historical coal consumption and coke production in coke plants. <p>Monitored:</p> <ul style="list-style-type: none"> • The type and amount of coal consumed in each coke plant (for process and fuel); • The quantity of fossil fuels combusted as a result of the project (i.e. in the operation of the DME production facility or power plant); • Electricity consumption in DMR plant.
<p>BASELINE SCENARIO Venting or flaring of COG. Use of unblended LPG fuel resulting in high CO₂ emissions.</p>	 <p>The baseline scenario flowchart (shaded in light orange) illustrates the current state. It shows two parallel paths. The top path starts with 'Coal' (flame icon) leading to 'Coke' (factory icon). From 'Coke', one arrow points to 'COG' (flame icon), which then leads to 'Flaring/Venting' (flame icon), resulting in 'CO₂' (flame icon). The bottom path starts with 'Fossil fuel' (flame icon) leading to 'LPG' (factory icon), then to 'LPG' (flame icon), which is used by a 'Consumer' (factory icon), resulting in 'CO₂' (flame icon).</p>
<p>PROJECT SCENARIO Use of all or part of the wasted COG to produce DME. This DME is supplied to LPG processing facilities for blending purpose. Thus, use of LPG is reduced.</p>	 <p>The project scenario flowchart (shaded in light green) illustrates the proposed changes. The top path remains the same: 'Coal' leads to 'Coke', which leads to 'COG'. However, instead of 'Flaring/Venting', the 'COG' is converted into 'DME' (represented by a factory icon). This 'DME' is then used to create 'Blended LPG' (flame icon). The bottom path shows 'Fossil fuel' leading to 'LPG' (factory icon), which then leads to 'Blended LPG' (flame icon). This 'Blended LPG' is used by a 'Consumer' (factory icon), resulting in 'CO₂' (flame icon). The 'Flaring/Venting' and its associated 'CO₂' emissions are crossed out with a large 'X', indicating they are eliminated or significantly reduced.</p>

AM0082 Use of charcoal from planted renewable biomass in the iron ore reduction process through the establishment of a new iron ore reduction system

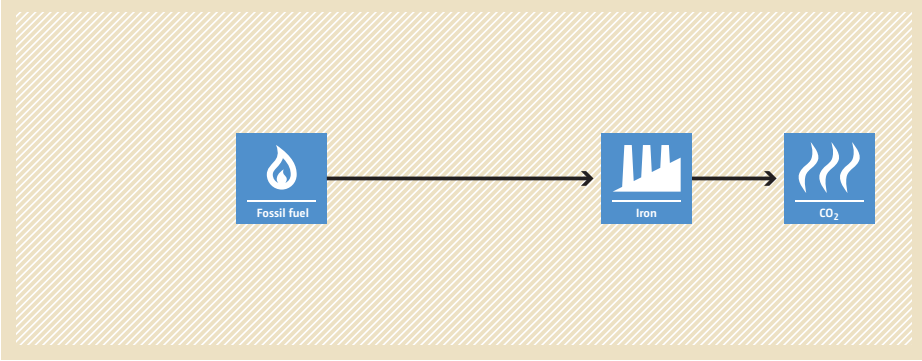
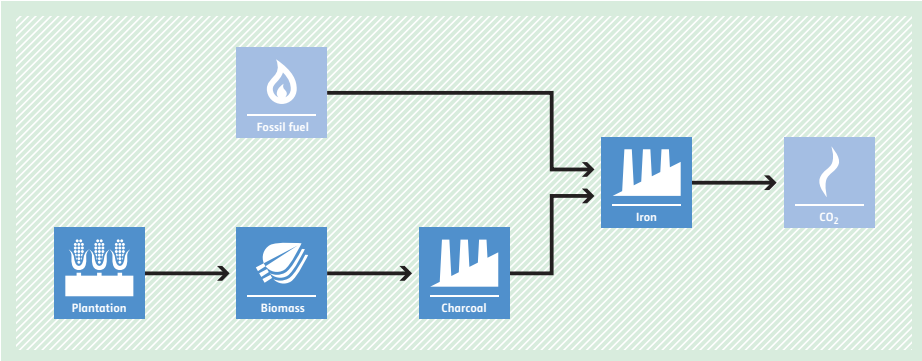
<p>Typical project(s)</p>	<p>Use renewable reducing agents such as charcoal produced from dedicated plantations instead of fossil fuel based reducing agents, in the iron ore reduction process using blast furnace technology. The project should include one or combination of the following new investment types: investment in dedicated plantations for the supply of reducing agents; or establishment of specific long-term binding contracts for the supply of reducing agents; or refurbishment/replacement of blast furnace; or establishment/acquisition of blast furnace; or adaptation of existing blast furnace to the use of charcoal.</p>
<p>Type of GHG emissions mitigation action</p>	<ul style="list-style-type: none"> • Renewable energy. Switch to a renewable source of carbon for the reduction of iron in blast furnaces.
<p>Important conditions under which the methodology is applicable</p>	<ul style="list-style-type: none"> • The renewable biomass used for charcoal production originates from a dedicated plantation in a tropical location of the host country where flood irrigation is not expected to take place; • The dedicated plantations should be located in the host country and under the control of project participants either directly owned or controlled through a long term contract; • Evidence should be available to demonstrate that the land of dedicated plantation falls into one of the following categories: grasslands; forest plantation after its last rotation or degraded areas; • The project does not use imported mineral coke or acquire biomass from the market.
<p>Important parameters</p>	<p>At validation:</p> <ul style="list-style-type: none"> • Carbonization yield. <p>Monitored:</p> <ul style="list-style-type: none"> • Parameters related to emissions from reducing agents production (carbonization and coal distillation); • Parameters related to iron ore reduction facility such as fuel/ reducing agent consumption, their emission factors, hot metal produced and its carbon content etc.
<p>BASELINE SCENARIO The hot metal in iron and steel plant is produced using reducing agents of fossil fuel origin, resulting into high amount of CO₂ emissions.</p>	 <p>The diagram shows a linear process flow. It starts with a box labeled 'Fossil fuel' containing a flame icon. An arrow points to a box labeled 'Iron' containing a factory icon. A second arrow points to a box labeled 'CO₂' containing a flame icon. The entire flow is set against a light brown background with diagonal hatching.</p>
<p>PROJECT SCENARIO The new iron ore reduction system partially or fully replaces fossil-fuel-based reducing agent with charcoal of renewable origin, resulting into reduction of CO₂ emissions.</p>	 <p>The diagram shows a more complex process flow. It starts with a box labeled 'Plantation' containing an icon of three hands holding soil. An arrow points to a box labeled 'Biomass' containing a leaf icon. Another arrow points to a box labeled 'Charcoal' containing a factory icon. From the 'Charcoal' box, an arrow points to a box labeled 'Iron' containing a factory icon. A second arrow from the 'Iron' box points to a box labeled 'CO₂' containing a flame icon. Additionally, there is a box labeled 'Fossil fuel' with a flame icon at the top, with an arrow pointing to the 'Iron' box. The entire flow is set against a light green background with diagonal hatching.</p>

AM0083 Avoidance of landfill gas emissions by in-situ aeration of landfills

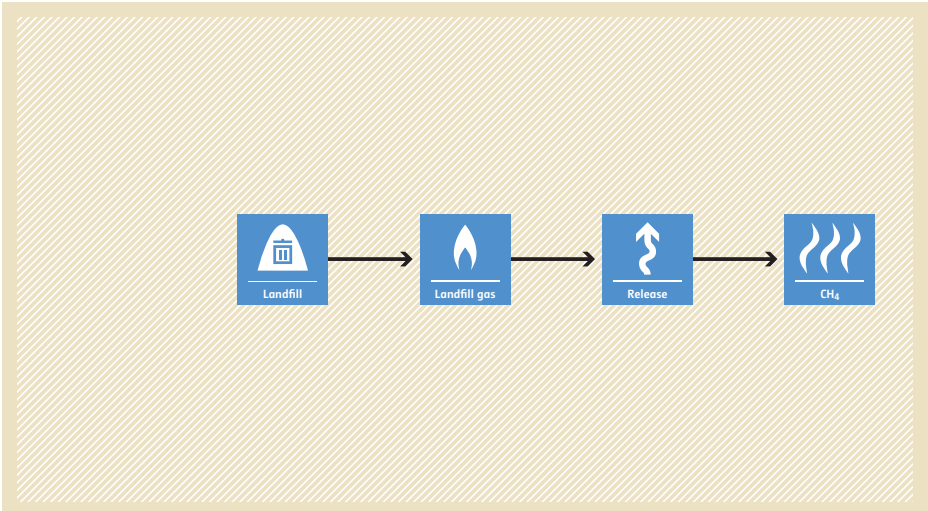
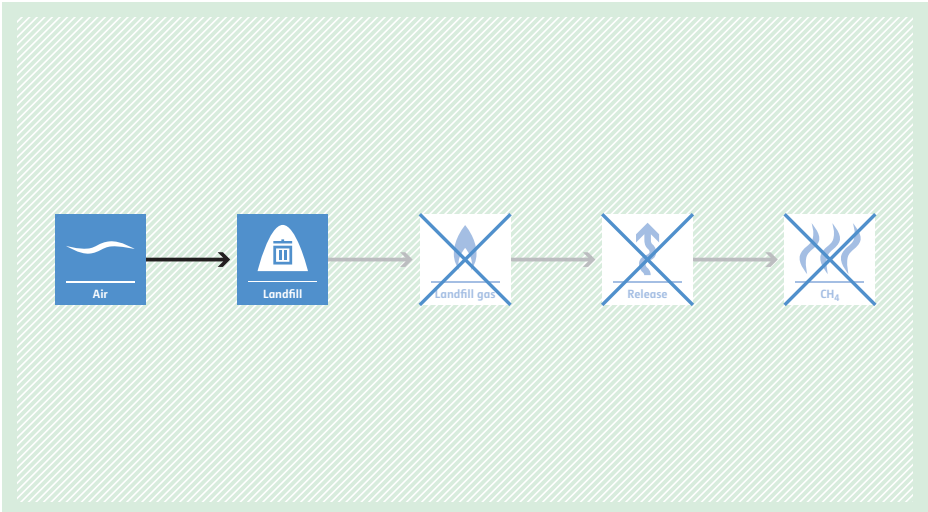
<p>Typical project(s)</p>	<p>Landfilled waste is treated aerobically on-site by means of air venting (overdrawing) or low pressure aeration with the objective of avoiding anaerobic degradation processes.</p>
<p>Type of GHG emissions mitigation action</p>	<ul style="list-style-type: none"> • GHG emission avoidance. <p>The project avoids CH₄ emissions from landfills.</p>
<p>Important conditions under which the methodology is applicable</p>	<ul style="list-style-type: none"> • Aeration techniques used are either air venting (overdrawing) or low pressure aeration; • Treatment of landfilled waste is in closed landfills or closed landfill cells; • If mandatory environmental regulations require the collection and flaring of landfill gas, the corresponding compliance rate is below 50% in the host country; • Closed cells of operating or closed landfills might be eligible as long as they are physically distinct from the remaining parts of the landfill.
<p>Important parameters</p>	<p>Monitored:</p> <ul style="list-style-type: none"> • Amount of degradable waste disposed in the landfill; • Potential methane generation capacity; • Vented and surface emissions: volume and methane and nitrous oxide content.
<p>BASELINE SCENARIO Partial or total release of landfill gas from the closed landfill or the closed landfill cell.</p>	 <p>The baseline scenario flowchart shows a linear process starting with a 'Landfill' icon (a trash can), followed by an arrow to 'Landfill gas' (a flame), another arrow to 'Release' (a wavy arrow pointing up), and a final arrow to 'CH₄' (a flame with wavy lines below it).</p>
<p>PROJECT SCENARIO In-situ aeration of the closed landfill or the closed landfill cell reduces GHG emissions.</p>	 <p>The project scenario flowchart shows a linear process starting with an 'Air' icon (a wavy line), followed by an arrow to a 'Landfill' icon (a trash can). From the landfill, an arrow points to 'Landfill gas' (a flame), which is crossed out with a large blue 'X'. Another arrow points to 'Release' (a wavy arrow pointing up), also crossed out with a large blue 'X'. A final arrow points to 'CH₄' (a flame with wavy lines below it), which is also crossed out with a large blue 'X'.</p>

AM0084 Installation of cogeneration system supplying electricity and chilled water to new and existing consumers

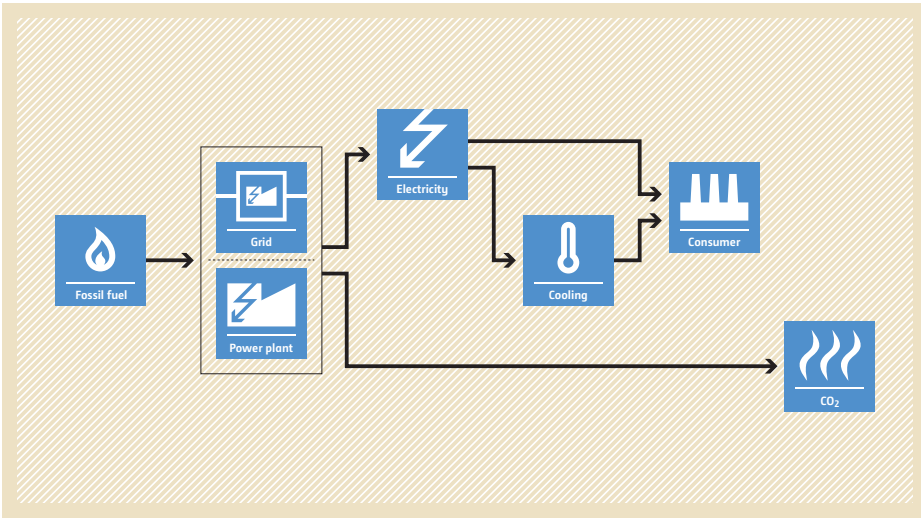
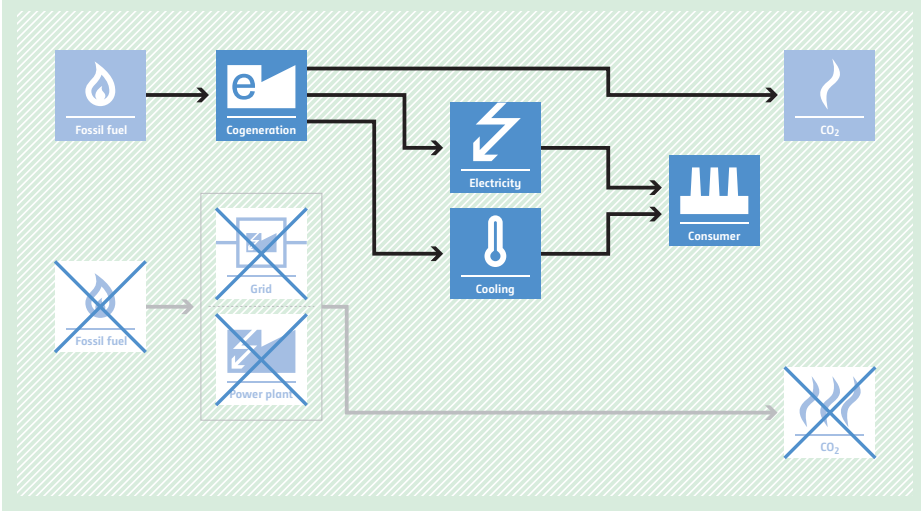
Typical project(s)	Installation of a new cogeneration plant producing chilled water and electricity.
Type of GHG emissions mitigation action	<ul style="list-style-type: none"> • Energy efficiency. • Displacement of electricity and cooling that would be provided by more-carbon-intensive means.
Important conditions under which the methodology is applicable	<ul style="list-style-type: none"> • The chilled water is supplied by vapour compression chillers in the baseline and in the case of existing baseline facilities only used on-site by customers; • After the implementation of the project, the cogeneration facility cannot supply services to facilities that are outside the project boundary; • The demand of electricity and water at a consumer cannot exceed 110% of its historical level for a cumulative period longer than three months.
Important parameters	At validation: <ul style="list-style-type: none"> • Power consumption of the baseline vapour compression chiller(s). Monitored: <ul style="list-style-type: none"> • Electricity generated and consumed by the project; • Chilled water generated by the project.
BASILINE SCENARIO Consumers use electricity provided by an on-site power plant or by the grid. Consumption of electricity for the production of chilled water by the use of electrical chillers (vapour compression chillers).	 <p>The diagram illustrates the baseline scenario. On the left, a 'Fossil fuel' icon (flame) has an arrow pointing to a box containing two options: 'Grid' (with a plug icon) and 'Power plant' (with a power plant icon). From this box, two arrows branch out: one to an 'Electricity' icon (lightning bolt) and one to a 'Cooling' icon (thermometer). Both 'Electricity' and 'Cooling' have arrows pointing to a 'Consumer' icon (factory). A separate arrow from the 'Power plant' box points to a 'CO₂' icon (flame with wavy lines), representing emissions.</p>
PROJECT SCENARIO Consumers use electricity provided by a fossil-fuel-fired cogeneration system. The cogeneration system provides electricity and chilled water.	 <p>The diagram illustrates the project scenario. On the left, a 'Fossil fuel' icon (flame) has an arrow pointing to a 'Cogeneration' icon (power plant with 'e' symbol). From the 'Cogeneration' icon, two arrows branch out: one to an 'Electricity' icon (lightning bolt) and one to a 'Cooling' icon (thermometer). Both 'Electricity' and 'Cooling' have arrows pointing to a 'Consumer' icon (factory). A separate arrow from the 'Cogeneration' icon points to a 'CO₂' icon (flame with wavy lines). Below this, a dashed box shows the 'Grid' and 'Power plant' options from the baseline scenario, with blue 'X' marks over them, indicating they are no longer used. A corresponding 'CO₂' icon below it also has a blue 'X' mark, indicating reduced emissions.</p>

AM0086 Installation of zero energy water purifier for safe drinking water application



<p>Typical project(s)</p>	<p>Zero-energy water purification systems are distributed to consumers to provide safe drinking water (SDW).</p>
<p>Type of GHG emissions mitigation action</p>	<ul style="list-style-type: none"> • Energy efficiency. • Displacement of more GHG intensive technologies to provide SDW.
<p>Important conditions under which the methodology is applicable</p>	<ul style="list-style-type: none"> • No public distribution network supplying SDW exists within the project boundary; • Project technology/equipment provides SDW based on laboratory testing or official notifications; • End users must have access to replacement purification systems; • Only for water purifiers sold or distributed within the first crediting period are eligible for claiming emissions reductions.
<p>Important parameters</p>	<p>At validation:</p> <ul style="list-style-type: none"> • Fraction of population served by zero-energy water purification technologies; • Population serviced by one project water purification system; • Volume of drinking water per person; • Fraction of population which would use electricity or fuel type i to boil water. <p>Monitored:</p> <ul style="list-style-type: none"> • Quantity of purified water consumed; • Failure rate of the project water purification systems; • Number of project water purification systems.
<p>BASELINE SCENARIO Energy consuming applications to produce safe drinking water will continue to be used in the households of a specific geographical area.</p>	<p>The diagram shows a flowchart for the baseline scenario. On the left, there are two input boxes: 'Water' (represented by a water drop icon) and 'Fossil fuel/Electricity' (represented by a flame and lightning bolt icons). Arrows from these inputs lead to a central box labeled 'Water purifier' (represented by a gear icon). From the 'Water purifier' box, two arrows emerge: one points to a 'Drinking water' box (represented by a glass of water icon) which then leads to a 'Consumer' box (represented by a person icon); the other arrow points to a 'CO2' box (represented by a flame icon).</p>
<p>PROJECT SCENARIO The zero-energy purifier displaces the current technologies/ techniques for generation of safe drinking water in the households of a specific geographical area.</p>	<p>The diagram shows a flowchart for the project scenario. On the left, there are two input boxes: 'Water' (represented by a water drop icon) and 'Fossil fuel/Electricity' (represented by a flame and lightning bolt icons). The 'Fossil fuel/Electricity' box is crossed out with a large 'X'. An arrow from the 'Water' box leads to a 'Water purifier' box (represented by a gear icon). From this 'Water purifier' box, two arrows emerge: one points to a 'Drinking water' box (represented by a glass of water icon) which then leads to a 'Consumer' box (represented by a person icon); the other arrow points to a 'CO2' box (represented by a flame icon). The 'CO2' box is also crossed out with a large 'X'. Additionally, there is a separate 'Water purifier' box (represented by a gear icon) that is also crossed out with a large 'X', and an arrow from the 'Fossil fuel/Electricity' box points to it, indicating that this technology is being displaced.</p>

AM0087 Construction of a new natural gas power plant supplying electricity to the grid or a single consumer

Typical project(s)	Installation of a natural-gas-fired power plant that supplies electricity to a grid and/or an existing facility that is also connected to the grid.
Type of GHG emissions mitigation action	<ul style="list-style-type: none"> • Low carbon electricity. Displacement of electricity that would be provided by more-carbon-intensive means.
Important conditions under which the methodology is applicable	<ul style="list-style-type: none"> • The project power plant generates only electricity and does not cogenerate heat; • No power was generated at the site of the new power plant prior to the project implementation; • Natural gas is sufficiently available in the region or country; • In case electricity is supplied to an existing facility: the facility has an operational history of at least three years, and the electricity is supplied through a dedicated electric line.
Important parameters	At validation: <ul style="list-style-type: none"> • Emission factor of baseline electricity, derived from an emission factor of the power grid, the power generation technology that would most likely be used in the absence of the project, or the one currently used at the existing facility. Monitored: <ul style="list-style-type: none"> • Fuel consumption of the project power plant; • Electricity supplied to the electric power grid and/or an existing facility.

BASELINE SCENARIO
Power generation using
1) natural gas, but with different technologies than the project,
2) fossil fuels other than natural gas or renewable energy, or
3) new or existing captive power plants at the existing facility or import of electricity from the grid.

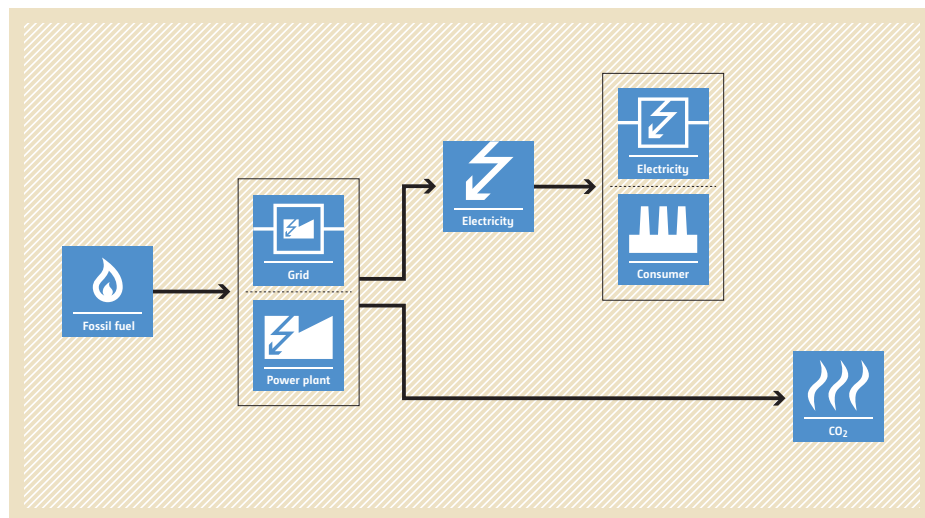

PROJECT SCENARIO
Power supply to the grid and/or an existing facility by a new natural-gas-fired power plant.

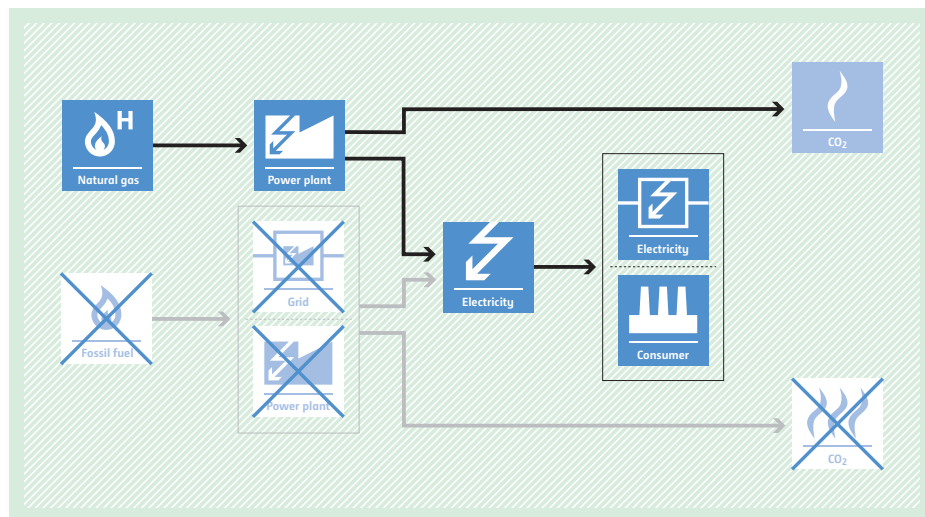

AM0088 Air separation using cryogenic energy recovered from the vaporization of LNG

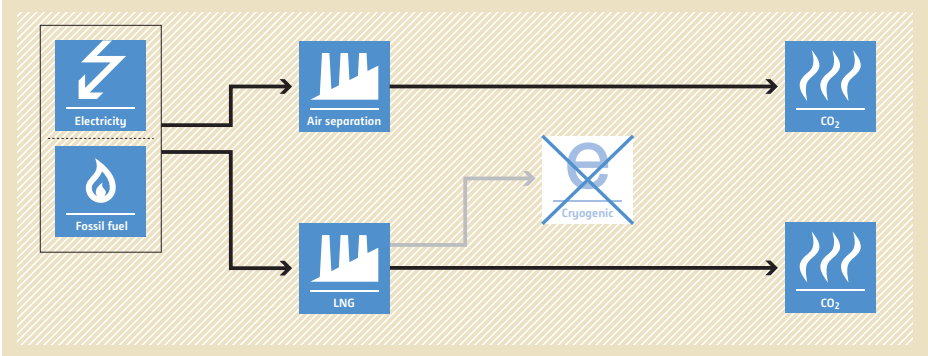
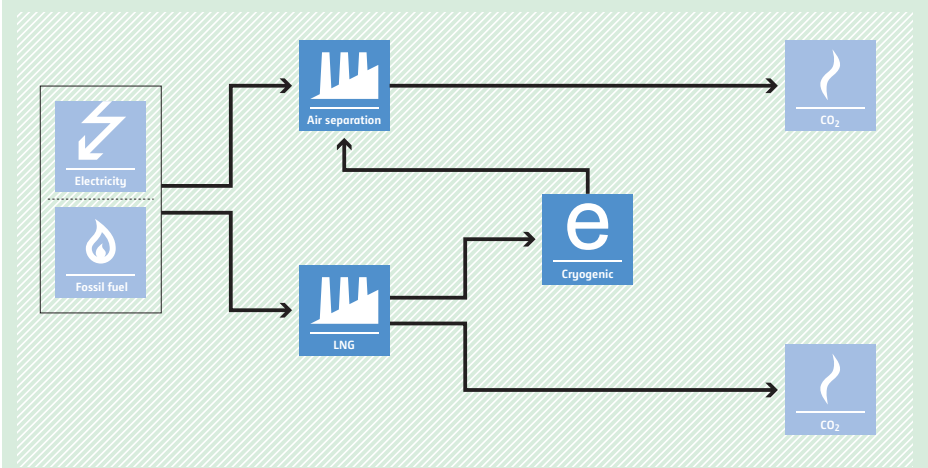
<p>Typical project(s)</p>	<p>The construction and operation of a new air separation plant that utilizes the cryogenic energy recovered from a new or existing LNG vaporization plant for the air separation process.</p>
<p>Type of GHG emissions mitigation action</p>	<ul style="list-style-type: none"> • Energy efficiency. <p>Reduction in heat consumption for LNG vaporization and fuels/electricity use in air separation plants.</p>
<p>Important conditions under which the methodology is applicable</p>	<ul style="list-style-type: none"> • The purity of the oxygen and nitrogen produced by the new air separation plant is equal to or higher than 99.5%; • The new air separation plant is located at the same site as the LNG vaporization plant; • The cryogenic energy from existing LNG vaporization plant was not utilized for useful purposes and was being wasted prior to the implementation of the project.
<p>Important parameters</p>	<p>At validation:</p> <ul style="list-style-type: none"> • Electricity emission factor (can also be monitored ex post); • Quantity of fossil fuels and electricity consumed by the air separation and the LNG Vaporization facilities; • Amount and physical properties of LNG vaporized. <p>Monitored:</p> <ul style="list-style-type: none"> • Quantity of fossil fuels and electricity consumed by the Air Separation and the LNG Vaporization facilities; • Amount and physical properties of LNG vaporized and gas produced at the separation plant.
<p>BASELINE SCENARIO The air separation process would use fossil fuels or electricity for cooling.</p>	 <p>The diagram illustrates the baseline scenario. On the left, two boxes represent 'Electricity' (lightning bolt icon) and 'Fossil fuel' (flame icon). Arrows from these boxes point to two separate factory icons: 'Air separation' and 'LNG'. From the 'Air separation' factory, an arrow points to a 'CO₂' box with a flame icon. From the 'LNG' factory, an arrow points to another 'CO₂' box with a flame icon. A third arrow points from the 'LNG' factory to a 'Cryogenic' box (letter 'e' icon), which is crossed out with a large 'X', indicating that this energy is wasted in the baseline scenario.</p>
<p>PROJECT SCENARIO The air separation process use cryogenic energy recovered from a LNG vaporization plant for cooling.</p>	 <p>The diagram illustrates the project scenario. On the left, 'Electricity' and 'Fossil fuel' boxes point to 'Air separation' and 'LNG' factories. From the 'LNG' factory, an arrow points to a 'Cryogenic' box (letter 'e' icon). From this 'Cryogenic' box, an arrow points to the 'Air separation' factory, indicating energy recovery. From the 'Air separation' factory, an arrow points to a 'CO₂' box with a flame icon. From the 'LNG' factory, an arrow points to another 'CO₂' box with a flame icon.</p>

AM0089 Production of diesel using a mixed feedstock of gasoil and vegetable oil

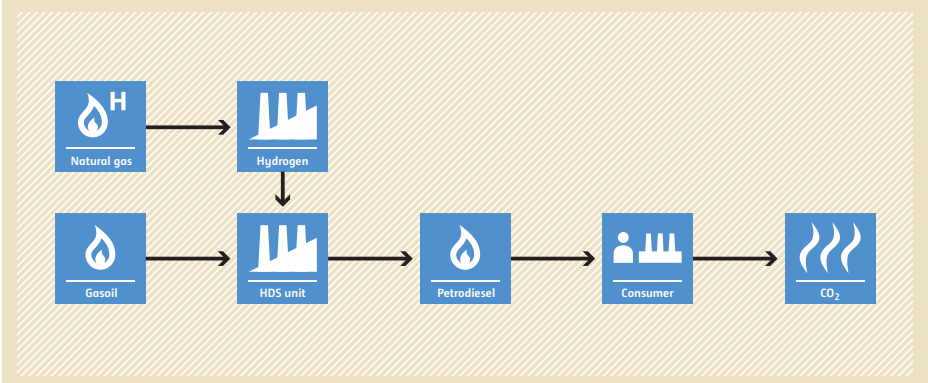
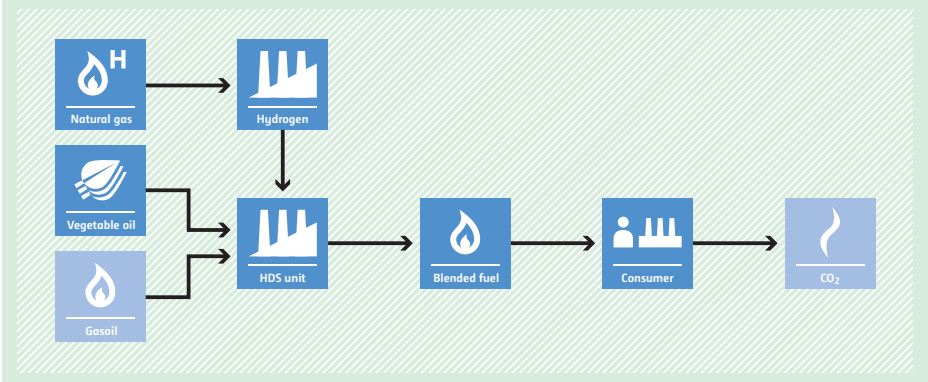
<p>Typical project(s)</p>	<p>Production of petro/renewable diesel by switching the feedstock of hydrodesulphurization process (HDS) unit from 100% gasoil to a mixture of gasoil and vegetable oil in an existing refinery, where the vegetable oil comes from oilseeds from plants that are cultivated on dedicated plantations established on lands that are degraded or degrading at the start of the project.</p>
<p>Type of GHG emissions mitigation action</p>	<ul style="list-style-type: none"> • Renewable energy; • Feedstock switch. <p>Displacement of more-GHG-intensive feedstock for the production of diesel.</p>
<p>Important conditions under which the methodology is applicable</p>	<ul style="list-style-type: none"> • Three years of historical data are required for the HDS unit; • Energy consumption in the HDS unit under the project is lower or equal to the baseline scenario and any combustible gases and off-gases formed during the hydrogenation of vegetable oil have to be flared or used in the refinery as fuel; • The petro/renewable diesel is not exported to an Annex I country.
<p>Important parameters</p>	<p>At validation:</p> <ul style="list-style-type: none"> • Ratio between the amount of renewable diesel produced and vegetable oil fed into HDS unit, density of renewable diesel. <p>Monitored:</p> <ul style="list-style-type: none"> • Amount of vegetable oil fed to HDS unit, volume of H₂ consumed in the HDS unit and amount of petro/renewable diesel produced by the project; • Project emissions from transport of oilseeds and/or vegetable oil if distances more than 50 km are covered; fossil fuel and electricity consumption of the vegetable oil production plant; • Leakage emissions related to the upstream emissions of excess natural gas and positive leakage associated with the avoided production of petrodiesel; • Destination of exported petro/renewable diesel produced by the project.
<p>BASELINE SCENARIO Diesel is produced from gasoil.</p>	 <pre> graph LR NG[Natural gas] --> H[Hydrogen] GO[Gasoil] --> HDS[HDS unit] H --> HDS HDS --> PD[Petrodiesel] PD --> C[Consumer] C --> CO2[CO2] </pre>
<p>PROJECT SCENARIO Diesel is produced from mixture of gasoil and vegetable oil.</p>	 <pre> graph LR NG[Natural gas] --> H[Hydrogen] VO[Vegetable oil] --> HDS[HDS unit] GO[Gasoil] --> HDS H --> HDS HDS --> BF[Blended fuel] BF --> C[Consumer] C --> CO2[CO2] </pre>

AM0090 Modal shift in transportation of cargo from road transportation to water or rail transportation

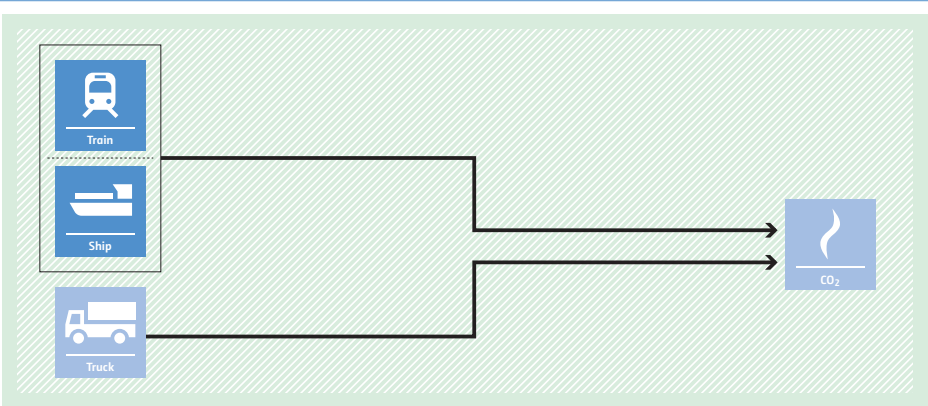
Typical project(s)	Transportation of cargo using barges, ships or trains.
Type of GHG emissions mitigation action	<ul style="list-style-type: none"> • Energy efficiency. • Displacement of a more-carbon-intensive transportation mode.
Important conditions under which the methodology is applicable	<ul style="list-style-type: none"> • The owner of the cargo is one of the project participants. If the entity investing in the project is not the owner of the cargo, it should also be a project participant; • The project should have made at least one of the following new investments: direct investment in new infrastructure for water transportation or for rail transportation, or refurbishment/replacement of existing water and rail transportation infrastructure or equipments, with transport capacity expansion; • The cargo type, transportation mode, and transportation routes of the project are defined at the validation of the project and no change is allowed thereafter; • Both in the baseline and project, only one type of cargo is transported and no mix of cargo is permitted.
Important parameters	<p>At validation:</p> <ul style="list-style-type: none"> • Distance of the baseline trip route (both forward and return trips). <hr/> <p>Monitored:</p> <ul style="list-style-type: none"> • Fuel and/or electricity consumption by the project transportation mode; • Amount of cargo transported by the project transportation mode (both forward and return trips).
<p>BASELINE SCENARIO The cargo is transported using trucks.</p>	
<p>PROJECT SCENARIO The cargo is transported using barges, ships or trains.</p>	

AM0091 Energy efficiency technologies and fuel switching in new and existing buildings



<p>Typical project(s)</p>	<p>Project activities implementing energy efficiency measures and/or fuel switching in new and existing building units (residential, commercial, and/or institutional building units). Examples of the measures include efficient appliances, efficient thermal envelope, efficient lighting systems, efficient heating, ventilation and air conditioning (HVAC) systems, passive solar design, optimal shading, building energy management systems (BEMS), and intelligent energy metering.</p>
<p>Type of GHG emissions mitigation action</p>	<ul style="list-style-type: none"> • Energy Efficiency. <p>Electricity and/or fuel savings through energy efficiency improvement. Use of less-carbon-intensive fuel.</p>
<p>Important conditions under which the methodology is applicable</p>	<ul style="list-style-type: none"> • Building units should belong to residential, commercial and institutional categories as defined in methodology; • Eligible sources of emissions include consumption of electricity, fossil fuel, and chilled water as well as leakage of refrigerant used in the building units; • Biogas, biomass or cogeneration systems should not be the source of thermal or electrical energy for project building units and chilled/hot water systems used for project building units; • All the project building units must comply with all applicable national energy standards (e.g. building codes) if they exist and are enforced.
<p>Important parameters</p>	<p>At validation:</p> <ul style="list-style-type: none"> • Emission factors of fuel used in baseline buildings; • Historical average retail price of the fuel most commonly used in the baseline building units. <p>Monitored:</p> <ul style="list-style-type: none"> • Total number of efficient appliances of type n that are used in registered CDM project(s) in the host country; • Gross floor area of project buildings; • Fuel consumption, quantity and energy content of hot/chilled water consumed and electricity consumption in project buildings; • Emission factors and calorific values of fuels.
<p>BASILINE SCENARIO Residential, commercial and institutional building units (similar to those constructed and then occupied in the project activity) will result in higher emissions due to fuel, electricity and chilled/hot water consumption.</p>	
<p>PROJECT SCENARIO Energy efficient residential, commercial and institutional project building units will result in lower emissions due to lower consumption of fuel, electricity and chilled/hot water.</p>	

AM0092 Substitution of PFC gases for cleaning Chemical Vapour Deposition (CVD) reactors in the semiconductor industry

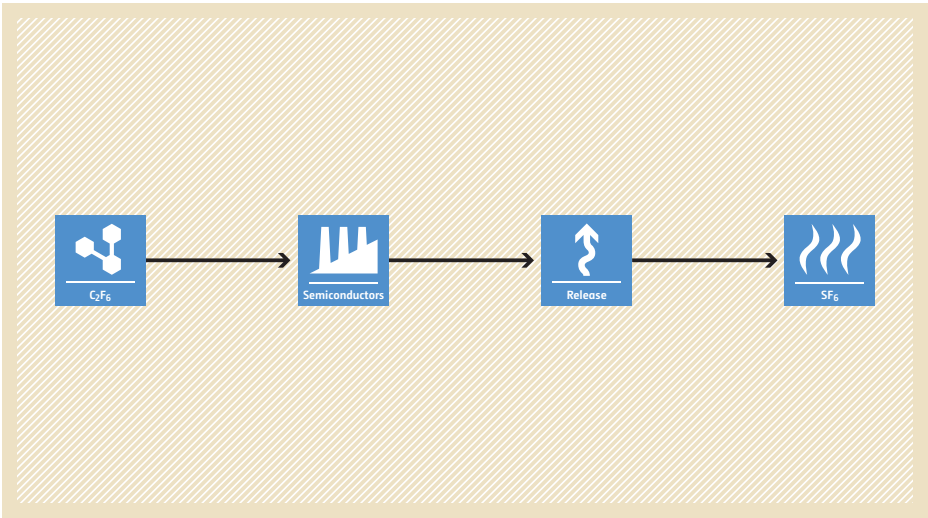
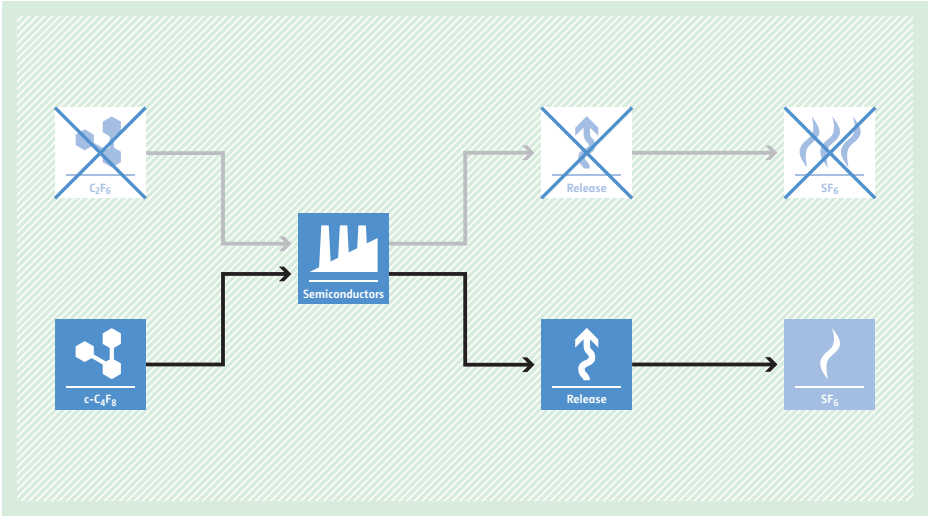
<p>Typical project(s)</p>	<p>Projects activities that reduce PFC emissions through replacement of C₂F₆ with c-C₄F₈ (octa-fluoro-cyclo-butane) as a gas for in-situ cleaning of CVD reactors in the semiconductor industry.</p>
<p>Type of GHG emissions mitigation action</p>	<ul style="list-style-type: none"> • Fuel or feedstock switch. <p>Displacement of C₂F₆ with c-C₄F₈.</p>
<p>Important conditions under which the methodology is applicable</p>	<ul style="list-style-type: none"> • Production lines included in the project boundary started commercial operation before 1 January 2010 and have an operational history of at least three years prior to the implementation of the project activity, during which the original PFC gas was C₂F₆; • The substitute PFC gas is not temporarily stored for subsequent destruction.
<p>Important parameters</p>	<p>At validation:</p> <ul style="list-style-type: none"> • Consumption of C₂F₆ in the baseline; • Production of substrate in the baseline.
	<p>Monitored:</p> <ul style="list-style-type: none"> • Consumption of c-C₄F₈; • Production of substrate.
<p>BASILINE SCENARIO The baseline scenario is the continuation of the current situation, i.e. the continuation of the same baseline feedstock (i.e. CVD reactors cleaned with C₂F₆)</p>	 <p>The diagram illustrates the baseline scenario as a linear process flow. It starts with a box labeled 'C₂F₆' containing a molecular structure icon. An arrow points to a box labeled 'Semiconductors' with a factory icon. Another arrow points to a box labeled 'Release' with an upward arrow icon. A final arrow points to a box labeled 'SF₆' with a flame icon. The entire flow is set against a light brown background with a diagonal hatching pattern.</p>
<p>PROJECT SCENARIO The project scenario is CVD reactors cleaned with c-C₄F₈.</p>	 <p>The diagram illustrates the project scenario, showing a substitution of the feedstock. It features two parallel paths leading to a central 'Semiconductors' box. The top path starts with a crossed-out 'C₂F₆' box, and the bottom path starts with a 'c-C₄F₈' box. Both paths lead to the 'Semiconductors' box. From there, two paths emerge: the top path leads to a crossed-out 'Release' box and then a crossed-out 'SF₆' box, while the bottom path leads to an active 'Release' box and then an active 'SF₆' box. The entire flow is set against a light green background with a diagonal hatching pattern.</p>

AM0093 Avoidance of landfill gas emissions by passive aeration of landfills

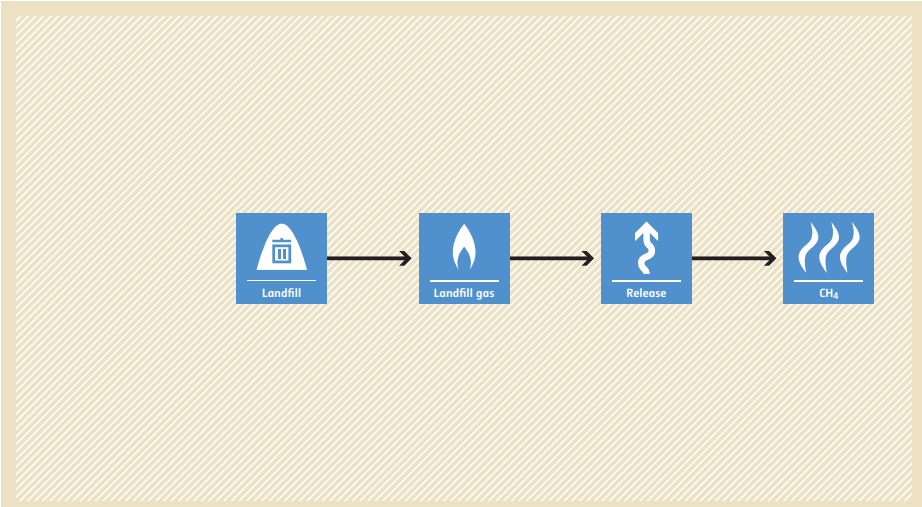
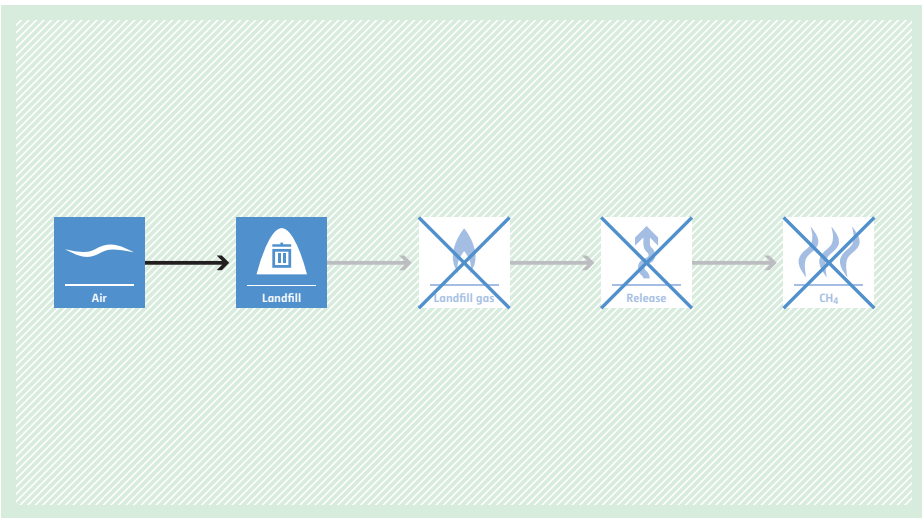
<p>Typical project(s)</p>	<p>Landfilled waste is treated aerobically on-site by means of passive aeration with the objective of avoiding anaerobic degradation processes.</p>
<p>Type of GHG emissions mitigation action</p>	<ul style="list-style-type: none"> • GHG emission avoidance. <p>The project avoids CH₄ emissions from landfills.</p>
<p>Important conditions under which the methodology is applicable</p>	<ul style="list-style-type: none"> • Treatment of landfilled waste is in closed landfills or closed landfill cells; • If mandatory environmental regulations require the collection and flaring of landfill gas, the corresponding compliance rate is below 50% in the host country; • Closed cells of operating landfills might be eligible as long as they are physically distinct from the remaining parts of the landfill; • Distance between vertical venting wells should not be more than 40m.
<p>Important parameters</p>	<p>At validation:</p> <ul style="list-style-type: none"> • Amount of biodegradable waste disposed in the landfill. <p>Monitored:</p> <ul style="list-style-type: none"> • Potential methane generation capacity; • Vented and surface emissions: volume and methane and nitrous oxide content.
<p>BASELINE SCENARIO Partial or total release of landfill gas from the closed landfill or the closed landfill cell.</p>	 <p>The diagram illustrates the baseline scenario for landfill gas emissions. It consists of four sequential steps connected by arrows: 1. 'Landfill' (represented by a trash can icon), 2. 'Landfill gas' (represented by a flame icon), 3. 'Release' (represented by an upward arrow icon), and 4. 'CH₄' (represented by a flame icon with the chemical formula). The entire process is set against a light brown background with a diagonal hatching pattern.</p>
<p>PROJECT SCENARIO In-situ passive aeration of the closed landfill or the closed landfill cell reduces GHG emissions.</p>	 <p>The diagram illustrates the project scenario for landfill gas emissions. It consists of five sequential steps connected by arrows: 1. 'Air' (represented by a wavy line icon), 2. 'Landfill' (represented by a trash can icon), 3. 'Landfill gas' (represented by a flame icon with a blue 'X' over it), 4. 'Release' (represented by an upward arrow icon with a blue 'X' over it), and 5. 'CH₄' (represented by a flame icon with a blue 'X' over it). The entire process is set against a light green background with a diagonal hatching pattern.</p>

AM0094 Distribution of biomass based stove and/or heater for household or institutional use



<p>Typical project(s)</p>	<p>Distribution of biomass based stoves and/or heaters and the supply of biomass briquettes for household or institutional use.</p>
<p>Type of GHG emissions mitigation action</p>	<ul style="list-style-type: none"> Renewable energy. <p>Displacement of more-GHG-intensive thermal energy production by introducing renewable energy technologies.</p>
<p>Important conditions under which the methodology is applicable</p>	<ul style="list-style-type: none"> The total project area (TPA) is defined prior to the start of the project activity and will not be changed later; Biomass penetration rate in the TPA is $\leq 10\%$; The biomass based stove or heater shall have a rated capacity of not more than 150 kW thermal; A contractual agreement between the project consumers and the project participants shall ensure that the project consumers do not claim any CERs from the use of stove and/or heater and biomass briquettes.
<p>Important parameters</p>	<p>At validation:</p> <ul style="list-style-type: none"> Percentage of biomass used as a fuel for cooking purposes or heating purposes, on energy basis, in project area(s); Proportion of fuel(s) used in the stoves or heaters in project area(s) in the baseline; Proportion of stove or heater type(s) used in project area(s) in the baseline. <p>Monitored:</p> <ul style="list-style-type: none"> Dry weight of biomass briquettes consumed by project consumer(s) in project area(s); NCV of biomass briquettes; Proportion of project stove or heater type(s) in use in project area(s).
<p>BASELINE SCENARIO Continuation of the use of existing stove or heater technologies and fossil fuels for thermal application.</p>	<pre> graph LR FF[Fossil fuel] --> H[Heat] H --> C[Consumer] H --> CO2[CO2] </pre>
<p>PROJECT SCENARIO Use of biomass based stoves and/or heaters and the supply of biomass briquettes for thermal application.</p>	<pre> graph LR B[Biomass] --> H[Heat] FF[Fossil fuel] --> H H --> C[Consumer] H --> CO2[CO2] FF --> X1[] CO2 --> X2[] style X1 stroke:#f00,stroke-width:2px style X2 stroke:#f00,stroke-width:2px </pre>

AM0095 Waste gas based combined cycle power plant in a Greenfield iron and steel plant

Typical project(s)	Project activities that construct and operate a captive or grid-connected combined cycle electricity generation power plant in a greenfield iron and steel plant, using waste gas such as blast furnace gas, coke oven gas, and converter gas sourced from the same facility.
Type of GHG emissions mitigation action	<ul style="list-style-type: none"> • Energy efficiency. Waste energy recovery in order to displace more-carbon-intensive source of energy.
Important conditions under which the methodology is applicable	<ul style="list-style-type: none"> • Specifications of coke oven and iron and steel plant has been determined before the project activity is considered; • The project participants have to demonstrate that the level of use of waste gas for power production in the iron and steel plant is the same in absence of and after the implementation of the CDM project activity.
Important parameters	<p>At validation:</p> <ul style="list-style-type: none"> • Data on waste gas based electricity generation in top 20% Rankine cycle based power plant in other iron and steel plants; • Energy Efficiency of waste gas based Rankine cycle based power plants in iron & steel plant using manufacturer's data. <p>Monitored:</p> <ul style="list-style-type: none"> • Data required to calculate grid emission factor; • Net Calorific Value of waste gas, and supplementary and auxiliary fuels; • Quantity of supplementary and auxiliary fuel fired and quantity of waste gas consumed by project power plant; • Net electricity generated by project power plant.

BASELINE SCENARIO
Construction of Rankine cycle based power plant using the same waste gas type and quantity as used in the project power plant.

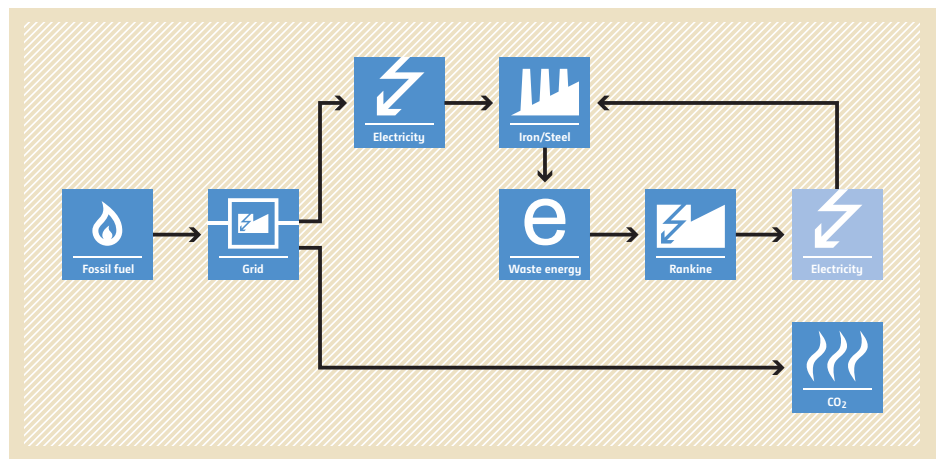

PROJECT SCENARIO
Energy efficient combined cycle based power plant recovering energy from waste gas in a greenfield iron and steel plant.

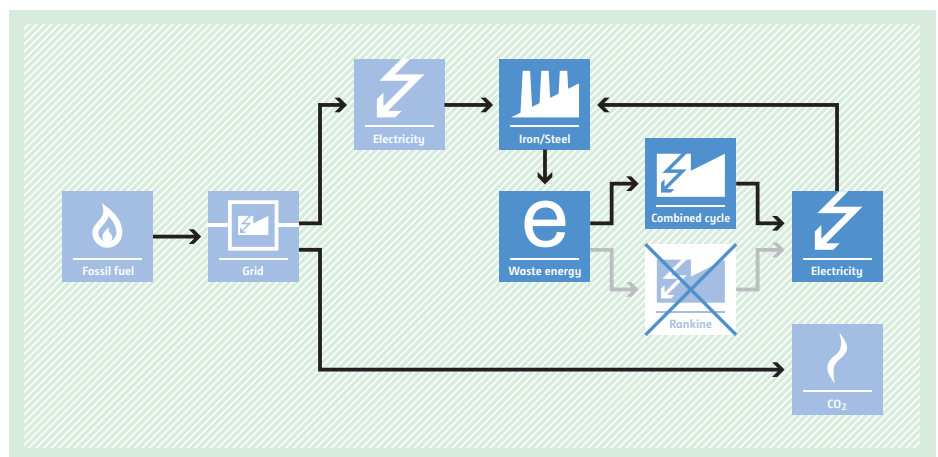

AM0096 CF₄ emission reduction from installation of an abatement system in a semiconductor manufacturing facility

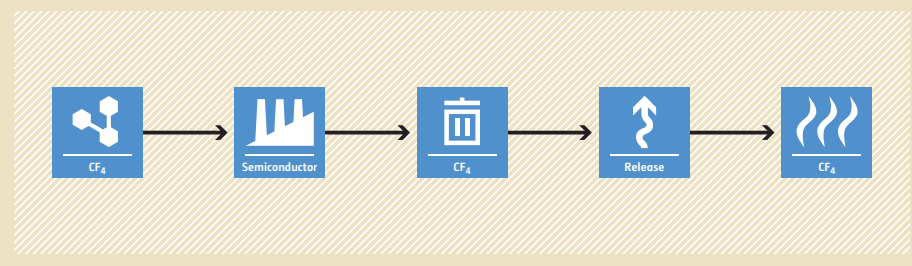
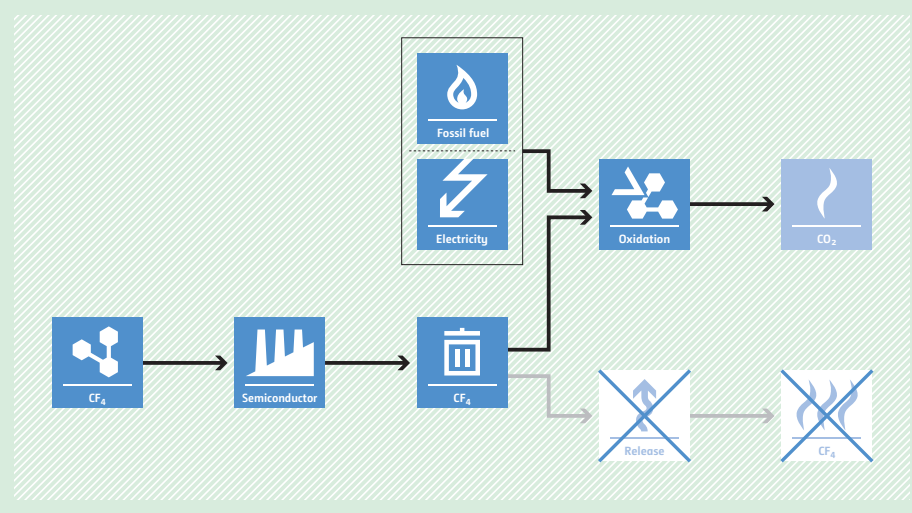
<p>Typical project(s)</p>	<p>Installation of an abatement system in an existing semiconductor manufacturing facility for the abatement of CF₄ from the semiconductor etching process.</p>
<p>Type of GHG emissions mitigation action</p>	<ul style="list-style-type: none"> • GHG destruction. <p>Destruction of CF₄ emissions.</p>
<p>Important conditions under which the methodology is applicable</p>	<ul style="list-style-type: none"> • Applicable to existing production lines without CF₄ abatement device installed and where CF₄ was being vented in the last three years; • CF₄ is not temporarily stored or consumed for subsequent abatement; • CF₄ abatement at the same industrial site where the CF₄ is used; and CF₄ to be abated is not imported from other facilities; • Not applicable to project activities which reduce emissions of PFCs from Chemical Vapour Deposition (CVD) processes.
<p>Important parameters</p>	<p>At validation:</p> <ul style="list-style-type: none"> • Amount of CF₄ consumed in years prior to the implementation of the project activity; • Amount of semiconductor substrate produced in years prior to the implementation of the project activity. <p>Monitored:</p> <ul style="list-style-type: none"> • Amount of CF₄ consumed; • Amount of semiconductor substrate produced; • Calibrated flow rate of Helium (He) gas added to duct before entering to the abatement system during a monitoring interval; • He concentration entering the abatement system and out of the abatement system; • Concentration of CF₄ in the gas entering the abatement system and in the gas leaving the abatement system; • Temperature at mass flow controller.
<p>BASELINE SCENARIO CF₄ is vented to the atmosphere after being used in the semiconductor etching process.</p>	 <p>The baseline scenario flowchart shows a linear process: CF₄ (represented by a hexagonal molecule icon) is used in a Semiconductor facility (factory icon). The output is CF₄ (hexagonal molecule icon), which is then released (upward arrow icon) into the atmosphere, resulting in CF₄ emissions (flame icon).</p>
<p>PROJECT SCENARIO CF₄ is recovered and destroyed in a catalytic oxidation unit (abatement system) located after the etching unit.</p>	 <p>The project scenario flowchart shows the same initial steps as the baseline: CF₄ is used in a Semiconductor facility, resulting in CF₄ output. However, instead of being released, the CF₄ is sent to an Oxidation unit. This unit is powered by Fossil fuel (flame icon) and Electricity (lightning bolt icon). The Oxidation unit produces CO₂ (flame icon) and destroys the CF₄, as indicated by a crossed-out Release icon and a crossed-out CF₄ emissions icon.</p>

AM0097 Installation of high voltage direct current power transmission line

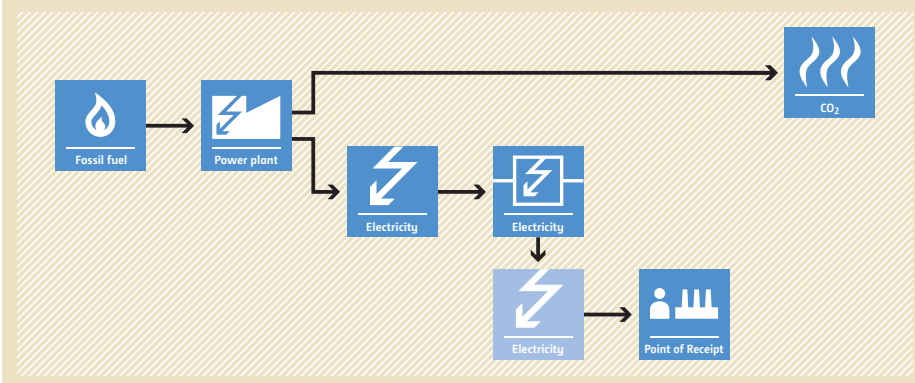
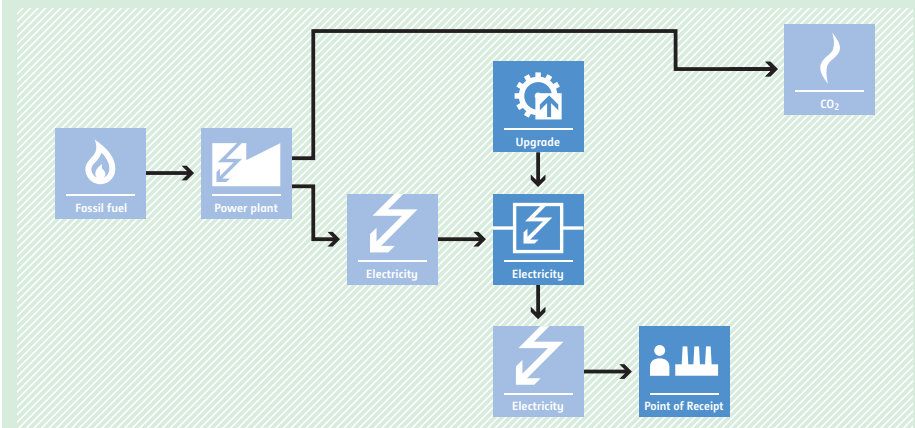
<p>Typical project(s)</p>	<ul style="list-style-type: none"> • Installation of Greenfield High Voltage Direct Current (HVDC) power transmission line/s for transmission of power from point of origin/supply to the point of receipt; or • Replacement of existing alternating current power transmission line by a new HVDC power transmission line.
<p>Type of GHG emissions mitigation action</p>	<ul style="list-style-type: none"> • Energy efficiency. Energy efficient electricity transmission line instead of inefficient electricity transmission line.
<p>Important conditions under which the methodology is applicable</p>	<ul style="list-style-type: none"> • Project participants shall invest in setting up a HVDC power transmission line and utilize it; • Project participant shall demonstrate through verifiable data that the right-of-way requirement for the project activity is less than for the baseline scenario; • This methodology is not applicable to project activities that seek to expand or retrofit existing grids by the construction of a new piece of HVDC transmission line.
<p>Important parameters</p>	<p>At validation:</p> <ul style="list-style-type: none"> • Data required for simulation software to calculate technical losses of baseline transmission line. This includes voltage, length, inductance, capacitance, and sub-station spacing of baseline transmission line. <p>Monitored:</p> <ul style="list-style-type: none"> • Gross electricity evacuated from the point of supply in project year using project transmission line; • Net electricity received at the point of receipt; • Right-of-way requirement for the transmission line under the project as well as under baseline.
<p>BASELINE SCENARIO Implementation or continuation of inefficient power transmission line.</p>	
<p>PROJECT SCENARIO Energy efficient HVDC transmission line.</p>	

AM0098 Utilization of ammonia-plant off gas for steam generation

<p>Typical project(s)</p>	<p>Utilization of ammonia-plant off gas (AOG), which was being vented, for heat generation at an existing ammonia production plant.</p>
<p>Type of GHG emissions mitigation action</p>	<ul style="list-style-type: none"> • GHG destruction. • Destruction of methane emissions and displacement of a more-GHG-intensive service.
<p>Important conditions under which the methodology is applicable</p>	<ul style="list-style-type: none"> • AOG is only used to generate steam to meet heat demands in the existing ammonia production plant and/or in nearby facilities in the same project site; • Amount of AOG vented from the start of operations at the existing ammonia production plant until the implementation of the project activity shall be demonstrated; • Regulations of the host country do not prohibit the venting of gases with the physical and chemical characteristics of the AOG.
<p>Important parameters</p>	<p>At validation:</p> <ul style="list-style-type: none"> • Volume of AOG vented by the existing ammonia production facility in historical years; • Total production of ammonia in historical years; • Average volume fraction of methane in the AOG in historical years. <p>Monitored:</p> <ul style="list-style-type: none"> • Volume of AOG recovered and used for steam generation by the project activity; • Total production of ammonia; • Average volume fraction of methane in the AOG recovered in the project activity; • Carbon density of AOG; • Net quantity of heat generated from AOG combustion; • Volume fraction of methane in the exhaust out of ammonia recovery section; • Volume of gaseous stream vented to the atmosphere out of the ammonia recovery section of AOG.
<p>BASELINE SCENARIO AOG is vented to the atmosphere.</p>	<p>The baseline scenario flowchart shows two parallel processes. On the left, 'Fossil fuel' (represented by a flame icon) is converted into 'Heat' (represented by a thermometer icon). This 'Heat' is then used for 'Ammonia' production (represented by a factory icon). The 'Ammonia' production process also generates 'AOG' (Ammonia-plant Off Gas, represented by a flame icon). The 'AOG' is then vented to the atmosphere, resulting in 'Release' (represented by an upward arrow icon) and 'CH4' emissions (represented by a flame icon). Additionally, the 'Heat' from fossil fuel is also used for other purposes, leading to 'CO2' emissions (represented by a flame icon).</p>
<p>PROJECT SCENARIO AOG is collected and utilized to generate heat.</p>	<p>The project scenario flowchart shows the same processes as the baseline scenario, but with a key change. The 'AOG' generated from ammonia production is now collected and used to generate 'Heat' (represented by a thermometer icon). This 'Heat' is then used for other purposes, leading to 'CO2' emissions (represented by a flame icon). The 'Fossil fuel' input is crossed out with a blue 'X', indicating it is no longer used. The 'AOG' input is also crossed out with a blue 'X', indicating it is no longer vented. The 'Release' and 'CH4' outputs remain the same.</p>

AM0099 Installation of a new natural gas fired gas turbine to an existing CHP plant

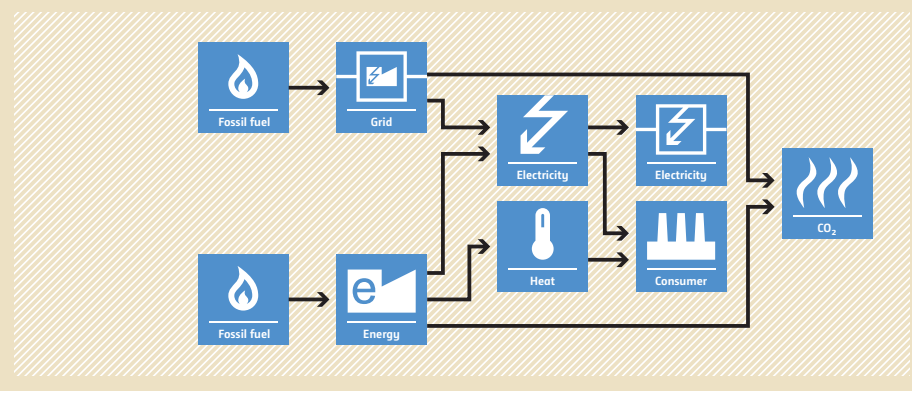
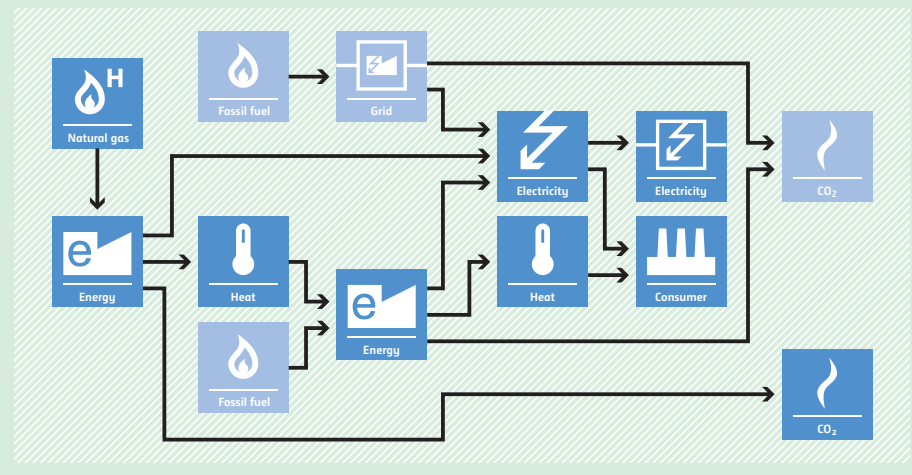
<p>Typical project(s)</p>	<p>Installation a new natural-gas-fired gas turbine at a site where there is an existing combined heat and power (CHP) plant and supply of the electricity to the grid or an existing electricity consuming facility and waste heat to the existing CHP plant.</p>
<p>Type of GHG emissions mitigation action</p>	<ul style="list-style-type: none"> • Low carbon electricity; • Energy efficiency. <p>Displacement of more-GHG-intensive electricity generation in a grid or captive power plant and supply of heat.</p>
<p>Important conditions under which the methodology is applicable</p>	<ul style="list-style-type: none"> • The steam from the heat recovery steam generator (HRSG) is not directly supplied to final users/consumers; • The existing CHP plant produced electricity and steam for at least three years prior to the implementation of the project activity.
<p>Important parameters</p>	<p>At validation:</p> <ul style="list-style-type: none"> • Amount of historical steam generation of the existing CHP; • Amount, emission factor and net calorific value (NCV) of fuel historically used to generate steam at the existing CHP plant. <p>Monitored:</p> <ul style="list-style-type: none"> • Electricity generated by the gas turbine that is fed into the grid and/or supplied to the electricity consuming facility; • Total electricity supplied to the grid by the existing steam turbine generator (STG) at the project site; • Steam generated by the project facility from heat recovery steam generator (HRSG); • Steam generated by the existing steam boilers.
<p>BASELINE SCENARIO Electricity is generated in the grid or captive power plant using more-carbon-intensive fuel and steam/heat is generated in existing steam boilers.</p>	 <p>The baseline scenario flowchart shows two inputs of 'Fossil fuel' (flame icon). One input goes to a 'Grid' (power lines icon), and the other goes to an 'Energy' (e icon) box. From the 'Grid', electricity flows to an 'Electricity' (lightning bolt icon) box. From the 'Energy' box, heat flows to a 'Heat' (thermometer icon) box. Both 'Electricity' and 'Heat' flow into a 'Consumer' (factory icon). From the 'Consumer', CO2 emissions (flame icon) are produced.</p>
<p>PROJECT SCENARIO Electricity is generated using natural gas and heat/steam is generated from waste heat from the gas turbine.</p>	 <p>The project scenario flowchart shows three inputs: 'Natural gas' (flame with H icon), 'Fossil fuel' (flame icon), and another 'Fossil fuel' (flame icon). 'Natural gas' and the first 'Fossil fuel' input go to a new 'Energy' (e icon) box. This 'Energy' box produces 'Heat' (thermometer icon). The second 'Fossil fuel' input goes to a 'Grid' (power lines icon). From the 'Grid', electricity flows to an 'Electricity' (lightning bolt icon) box. From the 'Energy' box, heat flows to a 'Heat' (thermometer icon) box. Both 'Electricity' and 'Heat' flow into a 'Consumer' (factory icon). From the 'Consumer', CO2 emissions (flame icon) are produced. Additionally, there is a direct path from the 'Energy' box to a 'CO2' (flame icon) box.</p>

AM0100 Integrated Solar Combined Cycle (ISCC) projects

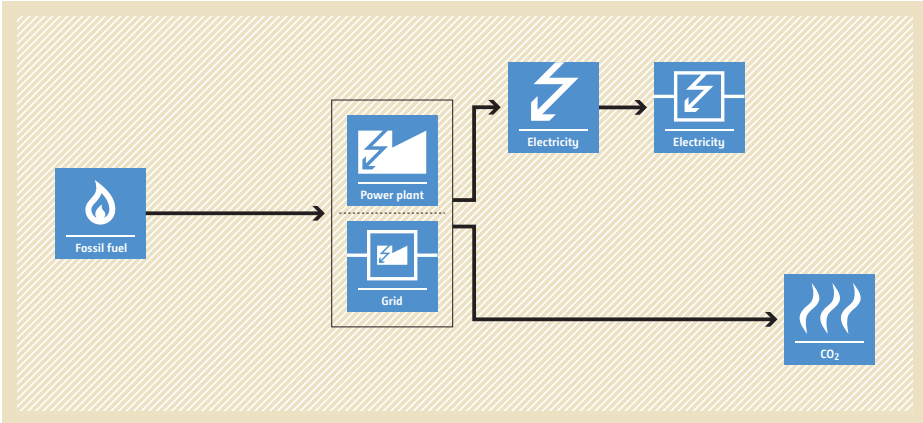
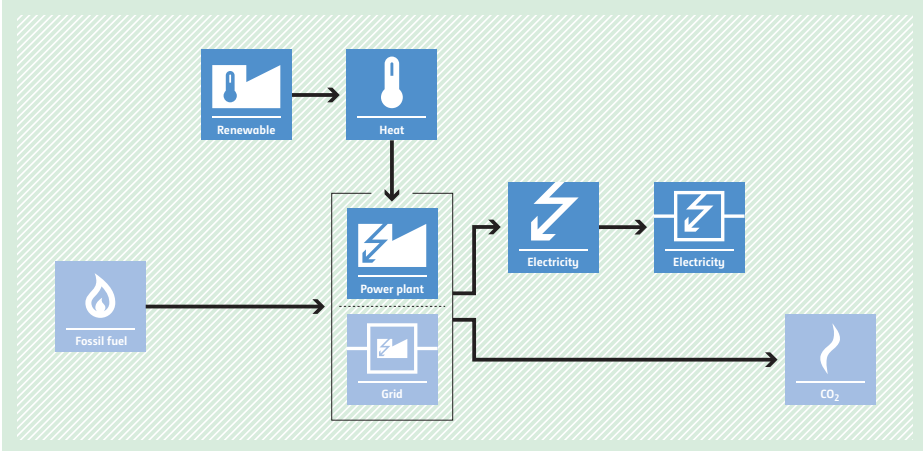
<p>Typical project(s)</p>	<p>Implementation of Integrated Solar Combined Cycle (ISCC) projects.</p>
<p>Type of GHG emissions mitigation action</p>	<ul style="list-style-type: none"> • Renewable Energy. <p>Displacement of electricity that would be provided to the grid by more-GHG-intensive means.</p>
<p>Important conditions under which the methodology is applicable</p>	<ul style="list-style-type: none"> • Applicable to: <ul style="list-style-type: none"> – Conversion of an existing Combined Cycle Power Plant into an ISCC; or – Conversion of an existing single cycle gas turbine power plant into an ISCC, where the project activity comprises exclusively the Solar Field and Supplementary Firing; or – Construction of a new ISCC, where the project activity comprises exclusively the Solar Field and Supplementary Firing; • Electric Solar Capacity does not account for more than 15% of the Electric Steam Turbine Capacity of the ISCC.
<p>Important parameters</p>	<p>Monitored:</p> <ul style="list-style-type: none"> • Average temperature, pressure and mass flow of steam leaving the solar steam generator; • Average temperature, pressure and mass flow of high pressure and low pressure steam entering the steam turbine and at the condenser outlet; • Gross electricity generation from gas turbine; • Net electricity generation from the ISCC; • Mass or volume, net calorific value (NCV), and emission factor of supplementary fuel; • Grid emission factor and/or emission factor of supplementary firing.
<p>BASELINE SCENARIO Electricity is generated in the grid using more-carbon-intensive fuel.</p>	 <p>The diagram illustrates the baseline scenario. On the left, a blue box labeled 'Fossil fuel' with a flame icon has an arrow pointing to a central box. This central box is divided into two sections: 'Power plant' (top) and 'Grid' (bottom). An arrow from the 'Power plant' section points to a blue box labeled 'Electricity' with a lightning bolt icon. From this 'Electricity' box, an arrow points to another 'Electricity' box. From the 'Grid' section, an arrow points to a blue box labeled 'CO₂' with a flame icon.</p>
<p>PROJECT SCENARIO Electricity is generated using steam generated from solar collectors and reducing the use of fossil fuel.</p>	 <p>The diagram illustrates the project scenario. On the left, a blue box labeled 'Fossil fuel' with a flame icon has an arrow pointing to a central box. This central box is divided into two sections: 'Power plant' (top) and 'Grid' (bottom). Above the 'Power plant' section, there is a blue box labeled 'Renewable' with a sun icon, an arrow pointing to a blue box labeled 'Heat' with a thermometer icon, and an arrow pointing down into the 'Power plant' section. From the 'Power plant' section, an arrow points to a blue box labeled 'Electricity' with a lightning bolt icon. From this 'Electricity' box, an arrow points to another 'Electricity' box. From the 'Grid' section, an arrow points to a blue box labeled 'CO₂' with a flame icon.</p>



AM0101 High speed passenger rail system

<p>Typical project(s)</p>	<p>Establishment and operation of a new high speed rail system. Extension of an existing high speed rail system. Replacement or upgrading of a conventional rail system to the high speed rail system.</p>
<p>Type of GHG emissions mitigation action</p>	<ul style="list-style-type: none"> Energy efficiency <p>Displacement of more GHG-intensive transport modes (airplanes, buses, conventional rail, motorcycles and personal cars) by less-GHG intensive one (high speed rail).</p>
<p>Important conditions under which the methodology is applicable</p>	<ul style="list-style-type: none"> The project establishes a new rail-based infrastructure for high speed rail. The new rail infrastructure can be the extension of an existing high speed rail system. It can also be the replacement or upgrading of an existing conventional rail system to high speed rail system; The methodology is applicable to inter-urban passenger transport only; The entire high speed rail system must be located in the same host country; The average distance between all stations served by the project high speed rail system is at least 20 km.
<p>Important parameters</p>	<p>At validation:</p> <ul style="list-style-type: none"> Data on parameters necessary to determine the baseline emission factors per passenger-kilometre of the relevant modes of transport and total trip distance travelled by passengers per baseline mode of transport. <p>Monitored:</p> <ul style="list-style-type: none"> Total number of passengers travelled by the project high speed rail system; Share of the project passengers or the number of passengers who would have travelled by the relevant modes of transport in absence of the project activity; Passenger trip distances.
<p>BASELINE SCENARIO Passengers transported between cities using a conventional transport system including buses, trains, cars, motorcycles and airplanes.</p>	<p>The diagram shows five transport mode icons (Train, Bus, Car, Motorcycle, Airplane) on the left. Lines from each icon converge and point to a single CO2 emissions icon on the right, representing the total emissions from the conventional transport system.</p>
<p>PROJECT SCENARIO Passengers are transported between cities by the high-speed passenger rail-based system that partially displaces the existing modes of inter-urban transport.</p>	<p>The diagram shows the same five transport mode icons as in the baseline scenario. However, the line from the 'Train' icon is significantly thicker and more prominent, indicating a larger share of passengers. The lines from the other modes (Bus, Car, Motorcycle, Airplane) are thinner, representing a partial displacement. All lines still converge to a CO2 emissions icon, but the overall thickness of the lines suggests a reduction in total emissions compared to the baseline scenario.</p>

AM0102 Greenfield cogeneration facility supplying electricity and steam to a Greenfield Industrial Consumer and exporting excess electricity to a grid and/or project customer(s)

Typical project(s)	Installation of an onsite Greenfield cogeneration plant for electricity and heat production supplied to a Greenfield industrial consumer.
Type of GHG emissions mitigation action	<ul style="list-style-type: none"> • Energy efficiency. Displacement of electricity and steam that would be provided by more-carbon-intensive means.
Important conditions under which the methodology is applicable	<ul style="list-style-type: none"> • The fuels used at the project facility must be gaseous or liquid; • The heat-to-power ratio of the project cogeneration facility shall be higher than 1; • The project facility must provide all of the electricity and heat/steam demand of the Greenfield industrial consumer; • The owner of the project facility is also the owner of the Greenfield industrial heat consuming facility.
Important parameters	At validation: <ul style="list-style-type: none"> • Historical power generation and fossil fuel consumption for captive power plants of project customers. Monitored: <ul style="list-style-type: none"> • Electricity generated by the project and consumed by the industrial consumer, the grid and project customers; • Steam/heat generated by the project and consumed by the industrial consumer.

BASELINE SCENARIO

Greenfield industrial consumer and project customers use electricity provided by captive power plants or by the grid. Greenfield industrial consumer uses fossil-fuel-fired boiler for steam production.

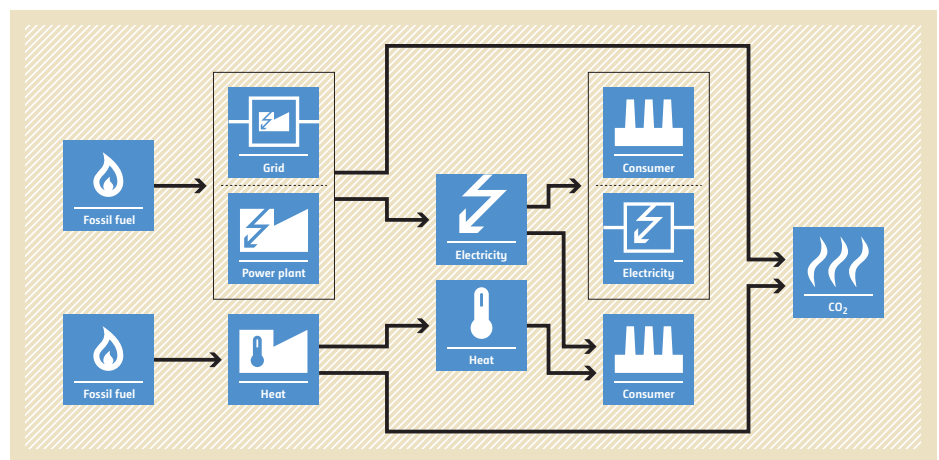

PROJECT SCENARIO

Greenfield industrial consumer uses only electricity and steam provided by the fossil-fuel-fired cogeneration system. Project customers use electricity provided by the fossil-fuel-fired cogeneration system.

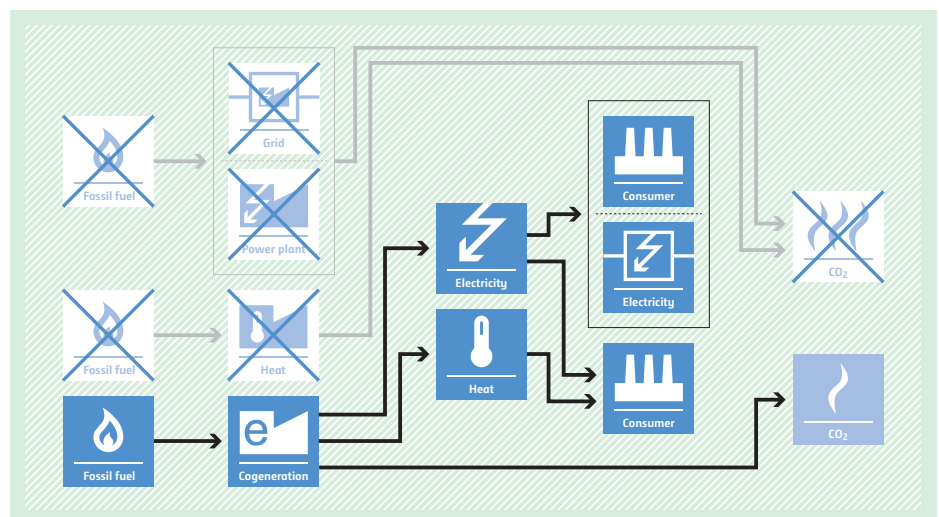

AM0103 Renewable energy power generation in isolated grids

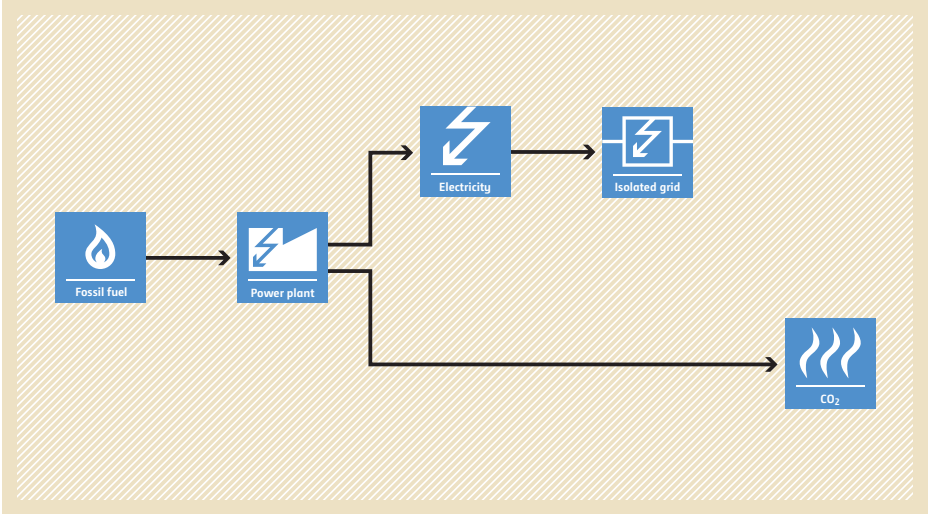
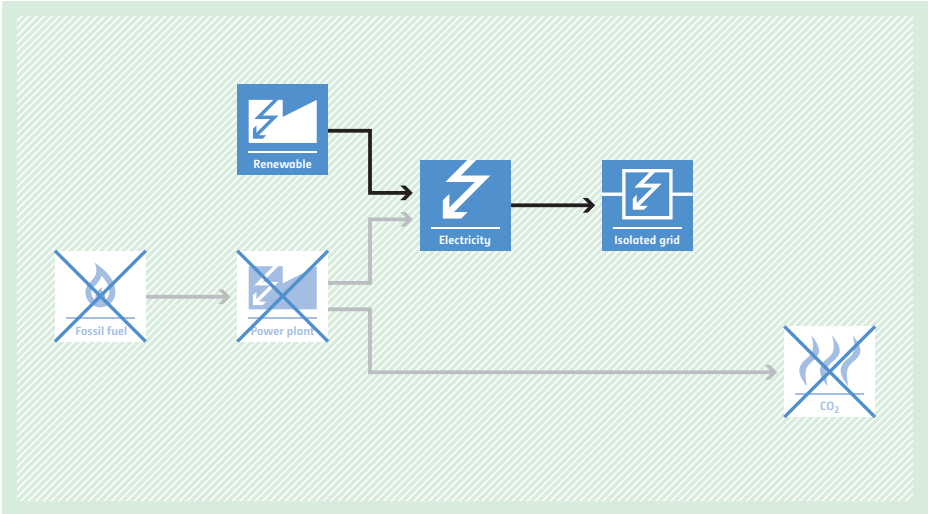
Typical project(s)	Power generation using renewable energy sources connected to a new or an existing isolated grid.
Type of GHG emissions mitigation action	<ul style="list-style-type: none"> • Renewable energy. Displacement of electricity that would be provided to the isolated grid by more-GHG-intensive means.
Important conditions under which the methodology is applicable	<ul style="list-style-type: none"> • The project power plant is using one of the following sources: hydro, wind, geothermal, solar, wave or tidal power. Biomass-fired power plants are not applicable; • In case of hydro power, specific applicability conditions apply.
Important parameters	At validation: <ul style="list-style-type: none"> • Emission factor of the isolated grid.
	Monitored: <ul style="list-style-type: none"> • Electricity supplied to the isolated grid by the project.
BASELINE SCENARIO Generation of electricity with fossil-fuel-fired generators (e.g. diesel generators).	 <p>The diagram illustrates the baseline scenario. It starts with a 'Fossil fuel' icon (a flame) on the left. An arrow points to a 'Power plant' icon (a lightning bolt with a flame). From the 'Power plant', two arrows branch out: one points to an 'Electricity' icon (a lightning bolt), which then points to an 'Isolated grid' icon (a lightning bolt inside a square). The other arrow from the 'Power plant' points directly to a 'CO2' icon (three wavy lines representing gas).</p>
PROJECT SCENARIO A renewable energy power plant displaces the energy that was generated by fossil fuel sources.	 <p>The diagram illustrates the project scenario. It shows a 'Renewable' icon (a lightning bolt) on the left. An arrow points to a 'Power plant' icon (a lightning bolt with a flame), which is crossed out with a large blue 'X'. From this 'Power plant', two arrows branch out: one points to an 'Electricity' icon (a lightning bolt), which then points to an 'Isolated grid' icon (a lightning bolt inside a square). The other arrow from the 'Power plant' points to a 'CO2' icon (three wavy lines representing gas), which is also crossed out with a large blue 'X'. A 'Fossil fuel' icon (a flame) is also crossed out with a large blue 'X' on the far left, indicating its displacement.</p>

AM0104 Interconnection of electricity grids in countries with economic merit order dispatch

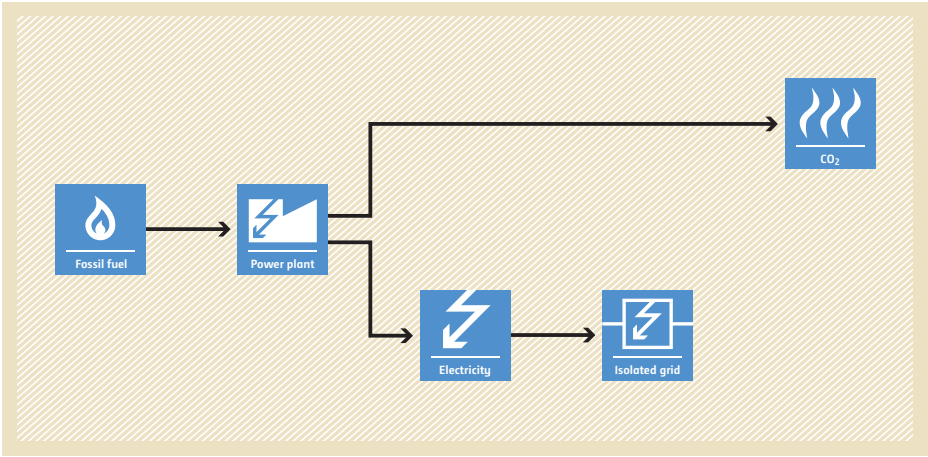
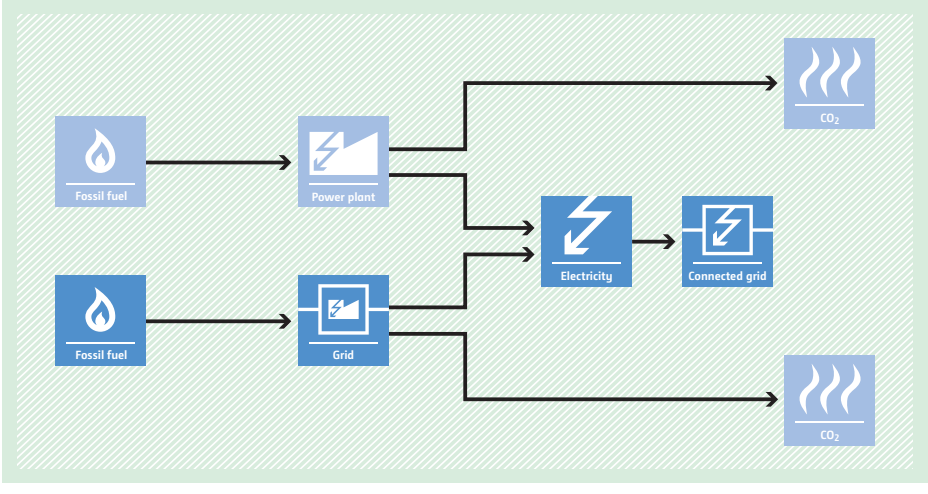
<p>Typical project(s)</p>	<p>Construction of one or multiple new interconnection lines to connect two grids (i.e. connection of a main grid and a previously isolated grid).</p>
<p>Type of GHG emissions mitigation action</p>	<ul style="list-style-type: none"> Displacement of a more-GHG-intensive output <p>Displacement of electricity that would be provided by more-GHG-intensive means.</p>
<p>Important conditions under which the methodology is applicable</p>	<ul style="list-style-type: none"> The total installed power capacity in the previously isolated grid is less than 10% of the total installed power capacity in the main grid in the year prior to the implementation of the project activity; Previously isolated grid is a grid that has no interconnection with any grid prior to the implementation of the project activity; After the implementation of the project activity, there will be only one dispatch centre responsible for the operation of the resulting grid (previously isolated and main grid).
<p>Important parameters</p>	<p>At validation:</p> <ul style="list-style-type: none"> Grid emission factor of the previously isolated grid. <p>Monitored:</p> <ul style="list-style-type: none"> Quantity of electricity delivered to the previously isolated grid; The average quantity of SF6 emitted from equipment installed under the project activity; Amount of electricity transferred from the previously isolated grid to the grid(s) other than the main grid.
<p>BASELINE SCENARIO No interconnection is constructed, and electricity demand of the isolated grid is met by power units connected to the isolated grid.</p>	 <p>The diagram illustrates the baseline scenario. On the left, a 'Fossil fuel' icon (flame) points to a 'Power plant' icon (power lines). From the power plant, an arrow points to an 'Electricity' icon (power lines). From the electricity icon, an arrow points to an 'Isolated grid' icon (power lines inside a square). From the isolated grid, an arrow points to a 'CO2' icon (flame with wavy lines). The entire diagram is set against a light brown background with a diagonal line pattern.</p>
<p>PROJECT SCENARIO Interconnection is constructed and electricity demand of the isolated grid is partially met by power units from the main grid.</p>	 <p>The diagram illustrates the project scenario. On the left, two 'Fossil fuel' icons (flame) point to two separate 'Grid' icons (power lines inside a square). From the top 'Grid' icon, an arrow points to a 'Power plant' icon (power lines). From the bottom 'Grid' icon, an arrow points to a 'Grid' icon (power lines inside a square). From the 'Power plant' icon, an arrow points to an 'Electricity' icon (power lines). From the bottom 'Grid' icon, an arrow points to the same 'Electricity' icon. From the 'Electricity' icon, an arrow points to a 'Connected grid' icon (power lines inside a square). From the 'Connected grid' icon, an arrow points to a 'CO2' icon (flame with wavy lines). From the top 'Grid' icon, an arrow points to another 'CO2' icon (flame with wavy lines). The entire diagram is set against a light green background with a diagonal line pattern.</p>

AM0105 Energy efficiency in data centres through dynamic power management

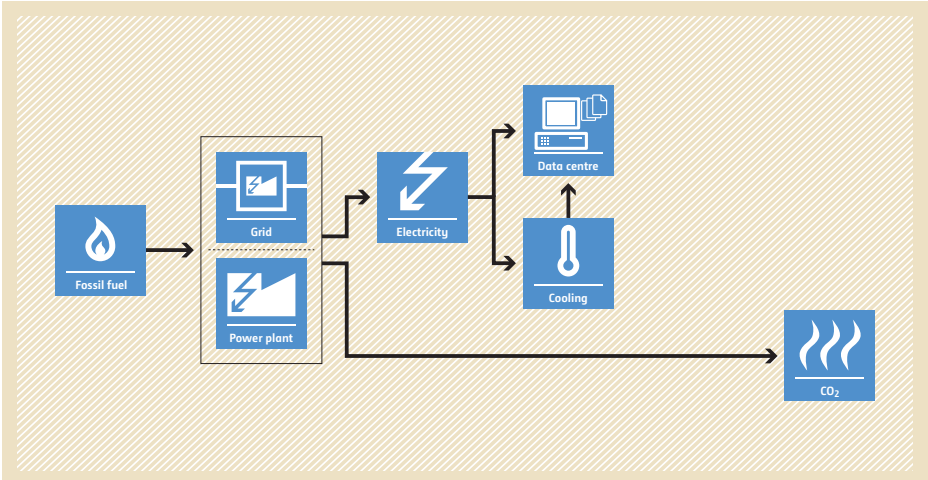
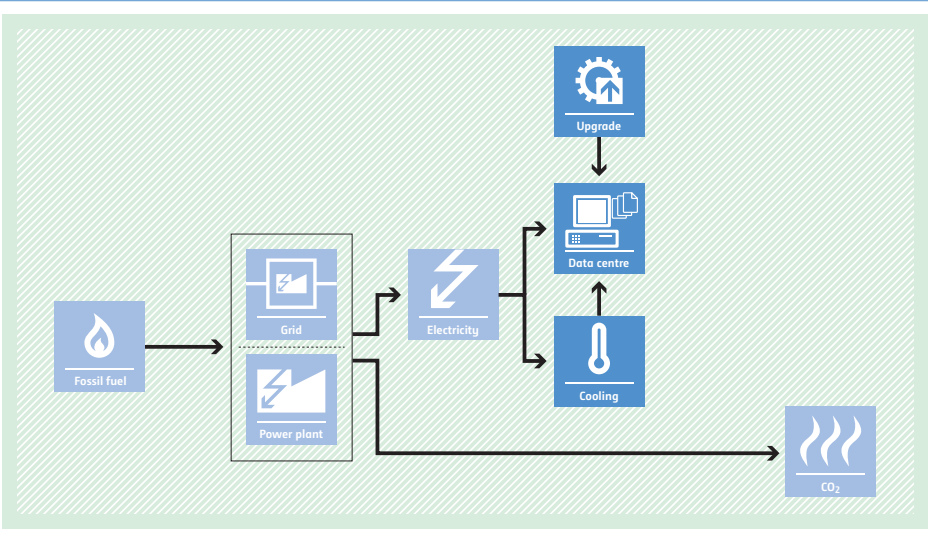
Typical project(s)	Introduction of dynamic power management (DPM) in an existing data centre.
Type of GHG emissions mitigation action	<ul style="list-style-type: none"> Energy efficiency The data centre will consume less electricity for the operation and cooling of its servers.
Important conditions under which the methodology is applicable	<ul style="list-style-type: none"> The project activity must be implemented in data centres that, prior to the implementation of the project activity, have no DPM system, no systematic method to adjust the data centre's total server capacity to actual demand, and no manual adjustment of server's operation mode to reduce electricity consumption.
Important parameters	At validation: <ul style="list-style-type: none"> Three years of historical load and operation hours information; Power consumption of the existing servers in idle mode and off mode; Transaction capacity of the existing servers; Grid emission factor (can also be monitored ex post). Monitored: <ul style="list-style-type: none"> Turn off time of the servers; Load of the servers; Market share of the technology.
BASILINE SCENARIO Servers of the data centre operate at "Always On" mode independent of demand.	 <p>The baseline scenario flowchart illustrates the energy flow from fossil fuel to a power plant, which feeds into the grid. Electricity from the grid is distributed to a data centre and a cooling system. The data centre is shown in an 'Always On' state, leading to higher electricity consumption and CO2 emissions. The cooling system also contributes to CO2 emissions.</p>
PROJECT SCENARIO Servers of the data centre are switched to "Off Mode" when not required to process transaction load.	 <p>The project scenario flowchart shows an 'Upgrade' step leading to a more efficient data centre. This results in reduced electricity consumption from the grid and lower CO2 emissions compared to the baseline scenario. The cooling system remains the same, but the overall energy demand is lower due to the 'Off Mode' servers.</p>

AM0106 Energy efficiency improvements of a lime production facility through installation of new kilns

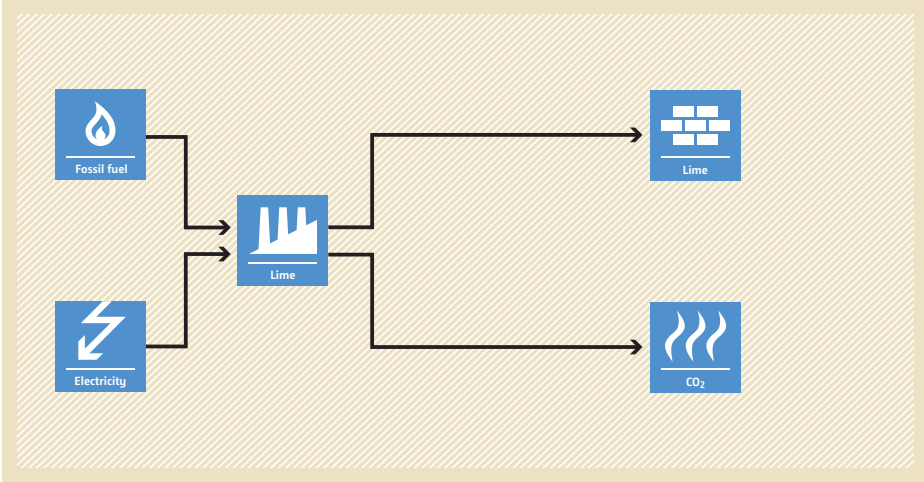
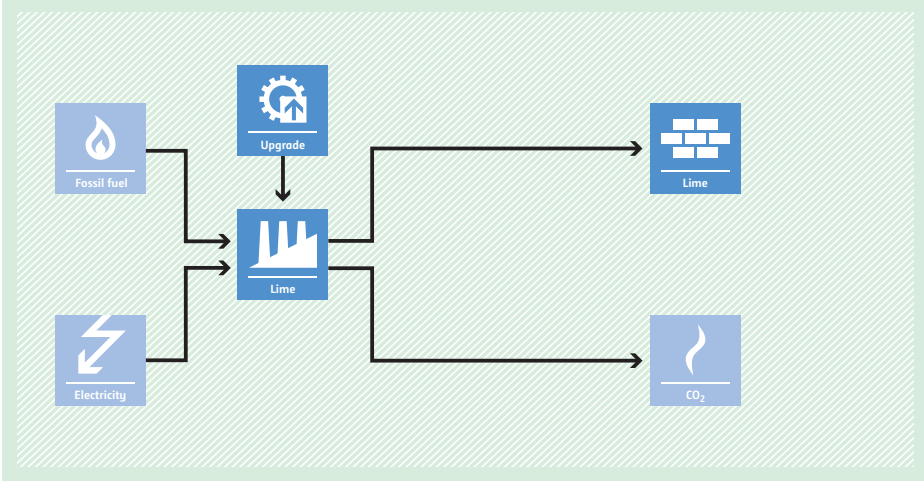
<p>Typical project(s)</p>	<p>Replacement of existing kilns by new and more energy-efficient kilns in an existing lime production facility.</p>
<p>Type of GHG emissions mitigation action</p>	<ul style="list-style-type: none"> • Energy efficiency <p>Production of lime using more energy-efficient technology.</p>
<p>Important conditions under which the methodology is applicable</p>	<ul style="list-style-type: none"> • The lime production facility is an existing facility and has operational history of at least three years prior to the start of the project activity; • The existing kilns and the new kilns use same fossil fuel; • The new kilns shall improve energy efficiency and not combustion efficiency; • The replaced kilns shall be decommissioned and not be used in another facility.
<p>Important parameters</p>	<p>At validation:</p> <ul style="list-style-type: none"> • Amount and net calorific value of the fuel consumed prior to the start of the project activity; • Amount of electricity consumed prior to the start of the project activity; • Amount of lime produced prior to the start of the project activity. <p>Monitored:</p> <ul style="list-style-type: none"> • Quantity of used limestone; • Amount of produced lime; • Amount and CO₂ emission factor of fuel and electricity.
<p>BASELINE SCENARIO Lime production using inefficient kilns.</p>	 <p>The diagram illustrates the baseline scenario for lime production. It features a central 'Lime' production icon (a factory with a chimney). Two input icons, 'Fossil fuel' (a flame) and 'Electricity' (a lightning bolt), have arrows pointing to the central 'Lime' icon. From the central 'Lime' icon, two output arrows point to 'Lime' (represented by a brick icon) and 'CO₂' (represented by a flame icon).</p>
<p>PROJECT SCENARIO Lime production using more energy-efficient kilns.</p>	 <p>The diagram illustrates the project scenario for lime production. It features a central 'Lime' production icon (a factory with a chimney). Two input icons, 'Fossil fuel' (a flame) and 'Electricity' (a lightning bolt), have arrows pointing to the central 'Lime' icon. Above the central 'Lime' icon is an 'Upgrade' icon (a gear with an upward arrow), with an arrow pointing down to the 'Lime' icon. From the central 'Lime' icon, two output arrows point to 'Lime' (represented by a brick icon) and 'CO₂' (represented by a flame icon).</p>

AM0107 New natural gas based cogeneration plant

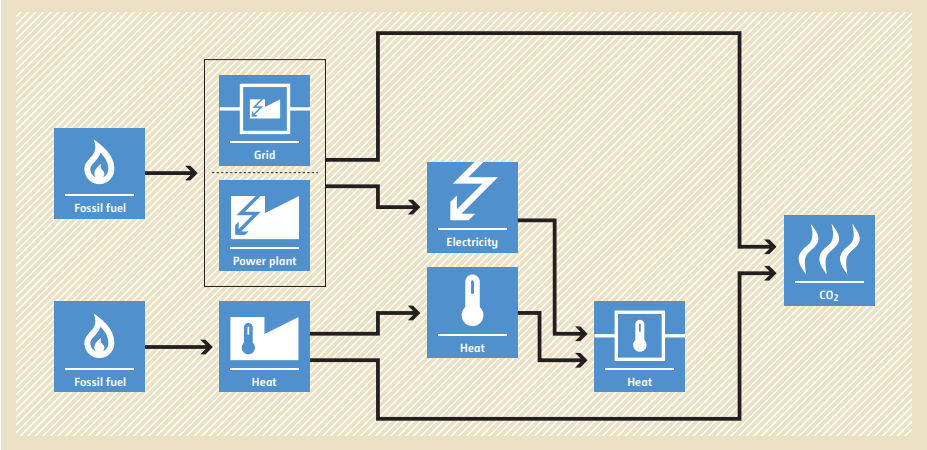
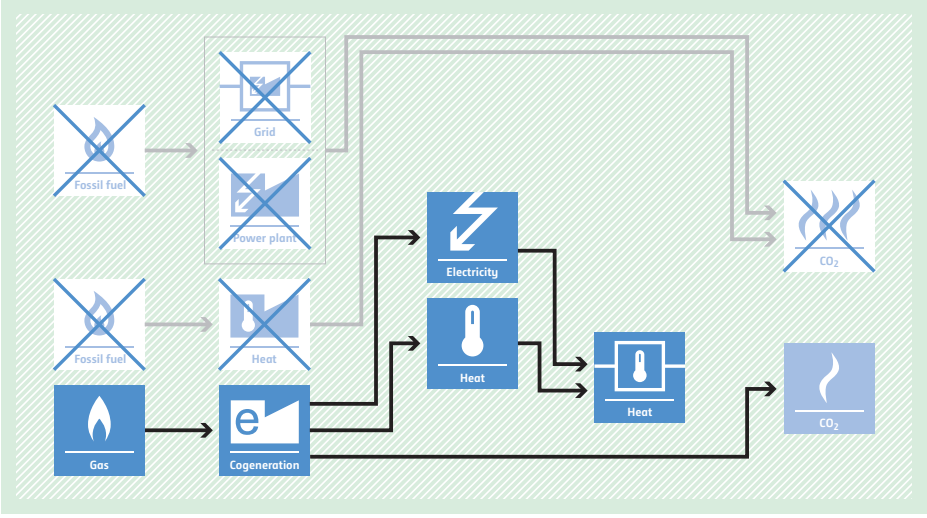
<p>Typical project(s)</p>	<p>Installation of a new cogeneration plant that use natural gas as fuel, supplies electricity to an electricity grid, and supplies heat to an existing or newly created heat network.</p>
<p>Type of GHG emissions mitigation action</p>	<ul style="list-style-type: none"> • Energy efficiency. <p>Displacement of electricity in the grid and/or heat that would be provided by more-carbon-intensive means.</p>
<p>Important conditions under which the methodology is applicable</p>	<ul style="list-style-type: none"> • Natural gas is used as main fuel in the project cogeneration plant; • Natural gas and baseline fuel are sufficiently available in the region or country; • The customers within the heat network do not co-generate heat and electricity currently.
<p>Important parameters</p>	<p>At validation:</p> <ul style="list-style-type: none"> • Average heat loss of the heat network; • Baseline emission factors for electricity and heat generation; • Net calorific value of fossil fuel fired in the cogeneration plant. <p>Monitored:</p> <ul style="list-style-type: none"> • Quantity of electricity generated in the project cogeneration plant that is fed into the electricity grid; • Quantity of heat supplied by the project activity; • Heat supplied by the heat generation facilities within the heat network; • Heat-to-electricity ratio of the cogeneration plant.
<p>BASELINE SCENARIO Electricity and heat would be produced by more-carbon-intensive technologies due to combustion of fossil fuels in power plants and heat plants.</p>	 <p>The diagram illustrates the baseline scenario. On the left, two boxes labeled 'Fossil fuel' with flame icons have arrows pointing to a 'Grid' box (with a lightning bolt icon) and a 'Power plant' box (with a lightning bolt icon). Below these, another two 'Fossil fuel' boxes have arrows pointing to a 'Heat' box (with a thermometer icon) and another 'Heat' box. Arrows from the 'Grid' and 'Power plant' boxes point to a central 'Electricity' box (with a lightning bolt icon). Arrows from the two 'Heat' boxes point to a central 'Heat' box (with a thermometer icon). From the 'Electricity' and 'Heat' boxes, arrows point to a final 'Heat' box. On the right, arrows from the 'Electricity' and 'Heat' boxes point to a 'CO2' box (with a flame icon).</p>
<p>PROJECT SCENARIO Electricity and heat are produced by natural gas based cogeneration plant.</p>	 <p>The diagram illustrates the project scenario. On the left, two 'Fossil fuel' boxes and one 'Gas' box (with a flame icon) are shown. The 'Fossil fuel' boxes and the 'Grid' and 'Power plant' boxes from the baseline scenario are crossed out with a large 'X'. Arrows from the 'Gas' box point to a 'Cogeneration' box (with a lightning bolt and 'e' icon). Arrows from the 'Cogeneration' box point to a central 'Electricity' box (with a lightning bolt icon) and a central 'Heat' box (with a thermometer icon). Arrows from the 'Cogeneration' box also point to a 'Heat' box (with a thermometer icon). On the right, arrows from the 'Electricity' and 'Heat' boxes point to a 'CO2' box (with a flame icon). The 'CO2' box from the baseline scenario is also crossed out with a large 'X'.</p>

AM0108 Interconnection between electricity systems for energy exchange

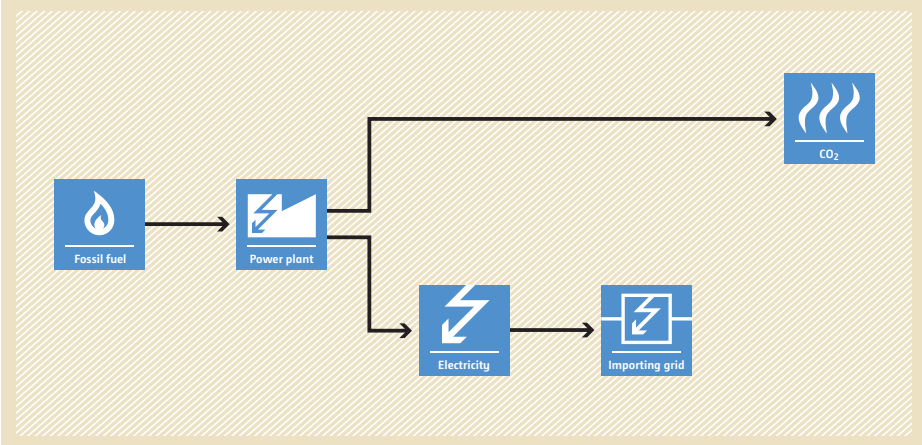
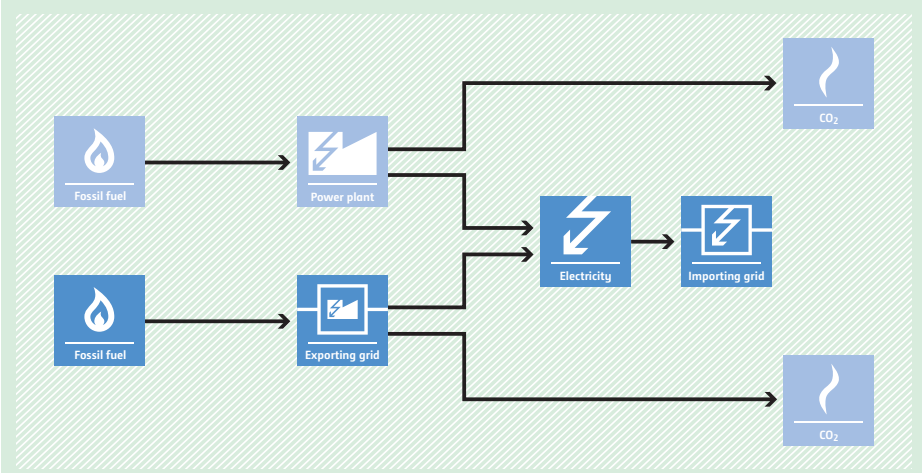
<p>Typical project(s)</p>	<p>Construction of one or multiple new interconnection lines to connect two systems (grids), i.e. connection of an exporting system and an importing system.</p>
<p>Type of GHG emissions mitigation action</p>	<ul style="list-style-type: none"> Displacement of a more-GHG-intensive output. <p>Displacement of electricity that would be provided by more-GHG-intensive means.</p>
<p>Important conditions under which the methodology is applicable</p>	<ul style="list-style-type: none"> The interconnection is through the construction of new transmission lines; The relation between annual electricity flow from the exporting system to the importing system and vice versa shall not fall below 80/20; The exporting system has more than 15 % of reserve capacity during the most recent year prior to the start of the crediting period.
<p>Important parameters</p>	<p>At validation:</p> <ul style="list-style-type: none"> Historical electricity transfers between exporting, importing and third party systems (if any). <p>Monitored:</p> <ul style="list-style-type: none"> Emission factor of the exporting and importing grids; Amount of electricity transferred between exporting and importing systems; Amount of electricity imported from the third party system to the exporting system; Amount of electricity exported from the importing system to the third party system; The average quantity of SF₆ emitted from equipment installed under the project activity.
<p>BASELINE SCENARIO No interconnection is constructed, and electricity demand of the importing system is met by power units in the importing system.</p>	 <p>The diagram illustrates the baseline scenario. On the left, a 'Fossil fuel' icon (flame) points to a 'Power plant' icon (factory with lightning bolt). From this power plant, an arrow labeled 'Electricity' points to an 'Importing grid' icon (grid with lightning bolt). To the right of the importing grid, another 'Fossil fuel' icon points to a second 'Power plant' icon. From this second power plant, an arrow labeled 'CO₂' points to a 'CO₂' icon (flame with wavy lines). The entire diagram is set against a light brown background with a diagonal hatching pattern.</p>
<p>PROJECT SCENARIO Interconnection is constructed and electricity demand of the importing system is partially met by power units from the exporting system.</p>	 <p>The diagram illustrates the project scenario. On the left, two 'Fossil fuel' icons (flames) each point to a 'Power plant' icon (factory with lightning bolt). The top power plant is connected to an 'Exporting grid' icon (grid with lightning bolt), and the bottom power plant is connected to an 'Importing grid' icon (grid with lightning bolt). An arrow labeled 'Electricity' points from the exporting grid to the importing grid. From the importing grid, an arrow labeled 'CO₂' points to a 'CO₂' icon (flame with wavy lines). From the top power plant, an arrow labeled 'CO₂' points to another 'CO₂' icon. The entire diagram is set against a light green background with a diagonal hatching pattern.</p>

AM0109 Introduction of hot supply of direct reduced iron in electric arc furnaces

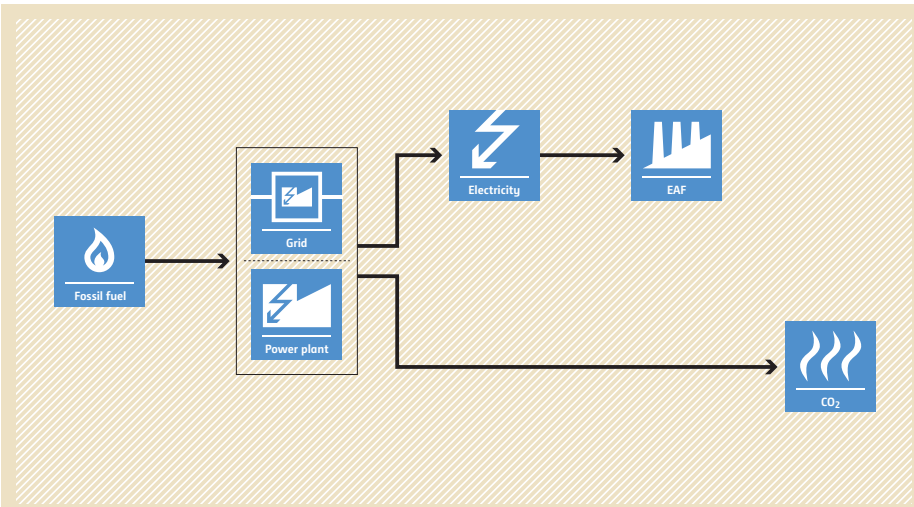
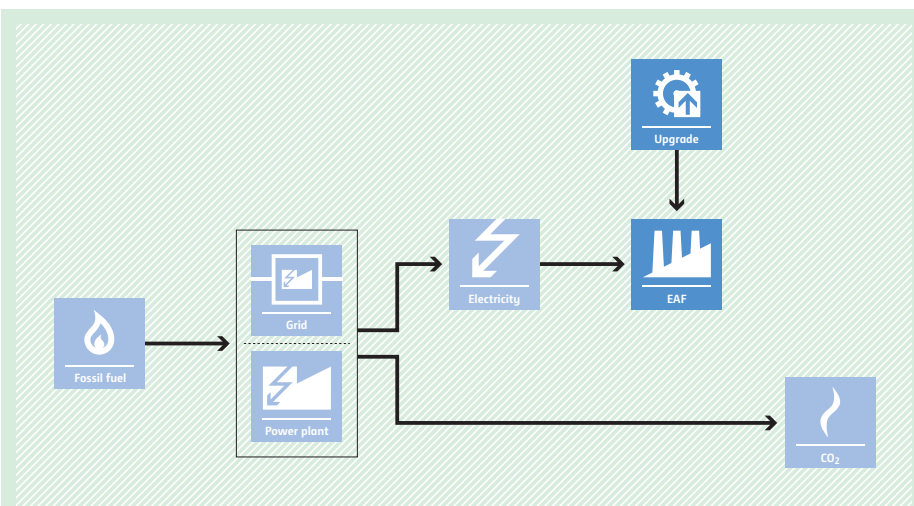
<p>Typical project(s)</p>	<p>Utilizing hot direct reduced iron (HDRI) instead of cold direct reduced iron (CDRI) as raw material in existing or new electric arc furnace/s (EAFs).</p>
<p>Type of GHG emissions mitigation action</p>	<ul style="list-style-type: none"> • Energy efficiency. <p>Switch to more energy-efficient technology.</p>
<p>Important conditions under which the methodology is applicable</p>	<ul style="list-style-type: none"> • The baseline is retrievable for the project activity; • The quality of output from EAF in hot DRI charging can vary by $\pm 5\%$ from the quality of output from EAF in cold DRI charging; • The project EAF unit(s) uses DRI from an on-site direct reduced plant (DRP) as source of iron during the crediting period.
<p>Important parameters</p>	<p>At validation:</p> <ul style="list-style-type: none"> • Metal production capacity of EAF. <p>Monitored:</p> <ul style="list-style-type: none"> • Electricity consumption in EAF and emission factors; • Electricity and fuel consumption in EAF charging system.
<p>BASILINE SCENARIO Due to cold DRI charging, high consumption of electricity in the electric arc furnaces results in high CO₂ emissions from the combustion of fossil fuel used to produce electricity.</p>	 <p>The diagram illustrates the baseline scenario. It starts with 'Fossil fuel' (represented by a flame icon) which is used to generate electricity through two paths: 'Grid' and 'Power plant' (both represented by lightning bolt icons). The electricity from both sources is then fed into an 'EAF' (Electric Arc Furnace, represented by a factory icon). The EAF produces 'CO₂' (represented by a flame icon with wavy lines), indicating high emissions due to the high electricity consumption.</p>
<p>PROJECT SCENARIO Due to hot DRI charging, electric arc furnaces consume less electricity, and thereby, CO₂ emissions from the combustion of fossil fuel used to produce electricity are reduced.</p>	 <p>The diagram illustrates the project scenario. It follows the same initial steps as the baseline: 'Fossil fuel' is used to generate electricity through 'Grid' and 'Power plant'. However, the electricity is then used by an 'EAF' that has undergone an 'Upgrade' (represented by a gear icon). This upgrade results in the EAF consuming less electricity, which in turn leads to a significant reduction in 'CO₂' emissions compared to the baseline scenario.</p>

AM0110 Modal shift in transportation of liquid fuels

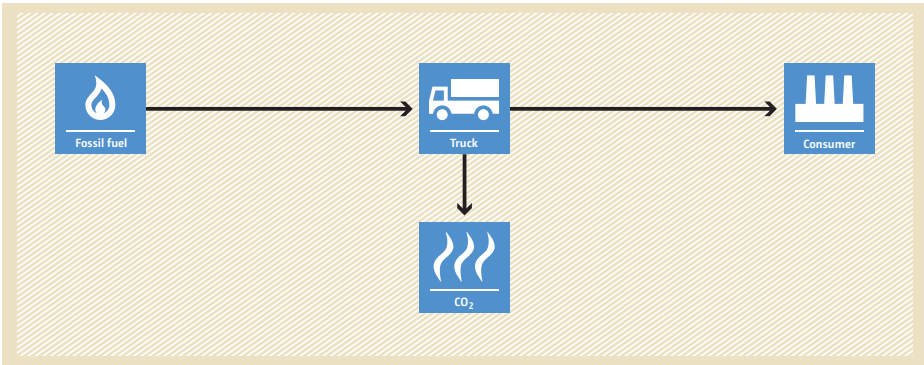
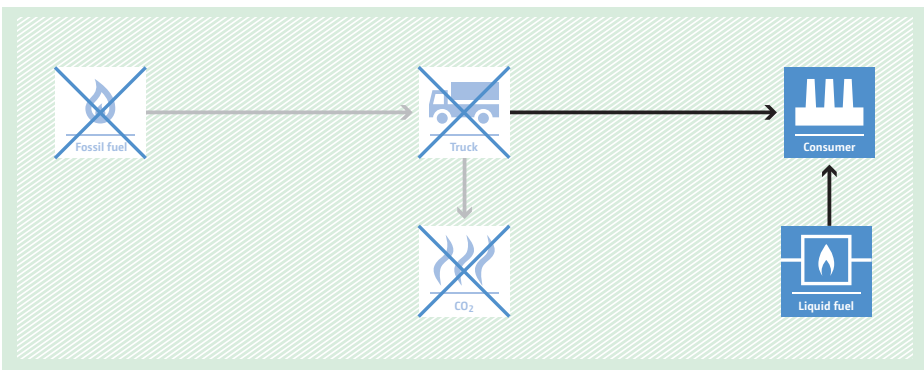
Typical project(s)	Transportation of liquid fuels using newly constructed pipeline.
Type of GHG emissions mitigation action	<ul style="list-style-type: none"> • Energy efficiency. • Displacement of a more-carbon-intensive transportation mode.
Important conditions under which the methodology is applicable	<ul style="list-style-type: none"> • The pipeline network operator is the project participant; • The liquid fuel is transported using two or multiple pre-identified nodes of pipeline network; • The type of liquid fuel to be transported under the project activity is defined in the CDM-PDD at the validation of the project activity and no change of type of liquid fuel is allowed thereafter; • Operational improvements of an existing pipeline that is in operation are not applicable; • The geographic conditions of the project site permit the use of different transportation means (e.g. pipeline, trucks, etc.); • There is sufficient road transportation capacity to transport the liquid fuel by trucks at the time of implementing the CDM project activity and for the duration of the crediting period.
Important parameters	<p>At validation:</p> <ul style="list-style-type: none"> • Amount of fuel consumed by the trucks for transportation of liquid fuel in route; • Distance of the baseline route; • Amount of liquid fuel transported in trucks.
	<p>Monitored:</p> <ul style="list-style-type: none"> • Amount of liquid fuel transported by the pipeline.
<p>BASELINE SCENARIO Liquid fuels are transported by trucks.</p>	 <p>The diagram illustrates the baseline scenario. It shows a flow from 'Fossil fuel' (represented by a flame icon) to a 'Truck' (represented by a truck icon), which then transports the fuel to a 'Consumer' (represented by a factory icon). A downward arrow from the truck points to a 'CO2' icon (represented by wavy lines), indicating emissions from the truck's operation.</p>
<p>PROJECT SCENARIO Liquid fuels are transported using a newly constructed pipeline.</p>	 <p>The diagram illustrates the project scenario. It shows a flow from 'Liquid fuel' (represented by a flame icon) to a 'Consumer' (represented by a factory icon). The 'Fossil fuel' and 'Truck' icons from the baseline scenario are crossed out with a large 'X', indicating they are no longer part of the project scenario. A 'CO2' icon is also crossed out, indicating that emissions from the truck are eliminated. A new arrow points from the 'Liquid fuel' icon to the 'Consumer' icon, representing the new pipeline route.</p>

AM0111 Abatement of fluorinated greenhouse gases in semiconductor manufacturing

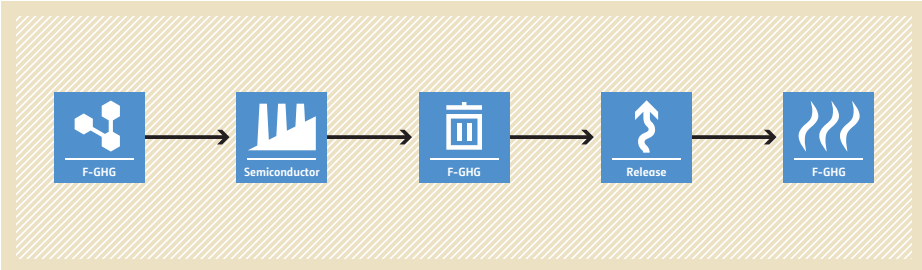
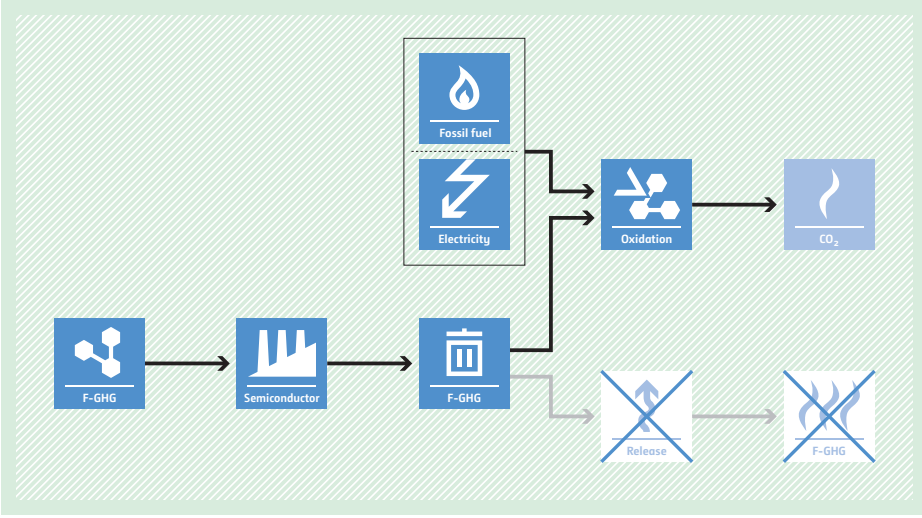
<p>Typical project(s)</p>	<p>Installation of an abatement system in an existing semiconductor manufacturing facility for the abatement of fluorinated GHGs (F-GHGs) from the semiconductor etching process.</p>
<p>Type of GHG emissions mitigation action</p>	<ul style="list-style-type: none"> • GHG destruction. <p>Destruction of various fluorinated GHGs (CF_4, C_2F_6, CHF_3, CH_3F, CH_2F_2, C_3F_8, $c-C_4F_8$, and SF_6).</p>
<p>Important conditions under which the methodology is applicable</p>	<ul style="list-style-type: none"> • Existing production lines are those that do not have F-GHG-specific abatement devices before January 2012; • At least three years of historical information; • F-GHGs have been vented in the three years prior to the project activity; • No regulations mandate abatement, recycling or substitution of the project gases.
<p>Important parameters</p>	<p>At validation:</p> <ul style="list-style-type: none"> • Operation conditions prior to implementation of the project activity; • Historical semiconductor production. <p>Monitored:</p> <ul style="list-style-type: none"> • Concentration of F-GHG at the inlet and outlet of the abatement system; • Flow of the gas stream at the inlet and outlet of the abatement system; • Operation conditions; • Semiconductor production; • Market share of baseline technology; • Mass of F-GHG at the inlet and outlet of the abatement system.
<p>BASELINE SCENARIO F-GHG is vented to the atmosphere after being used in the semiconductor etching process.</p>	 <p>The baseline scenario flowchart shows a linear process: F-GHG (represented by a molecule icon) is used in a Semiconductor (factory icon) facility. The resulting F-GHG (molecule icon) is then released (upward arrow icon) into the atmosphere, where it is represented as F-GHG (flame icon).</p>
<p>PROJECT SCENARIO F-GHG is recovered and destroyed in a catalytic oxidation unit (abatement system) located after the etching unit.</p>	 <p>The project scenario flowchart shows the same initial steps as the baseline: F-GHG (molecule icon) is used in a Semiconductor (factory icon) facility, resulting in F-GHG (molecule icon). However, instead of being released, the F-GHG is sent to an Oxidation unit (flame and lightning bolt icon). This unit also receives input from Fossil fuel (flame icon) and Electricity (lightning bolt icon). The output of the Oxidation unit is CO₂ (flame icon). A separate path shows F-GHG (molecule icon) being released (upward arrow icon) and then F-GHG (flame icon), but both the Release and F-GHG (flame icon) boxes are crossed out with a large 'X', indicating that this path is eliminated in the project scenario.</p>

AM0112 Less carbon intensive power generation through continuous reductive distillation of waste



<p>Typical project(s)</p>	<p>Project activities where waste is treated by applying continuous reductive distillation (CRD) technology and resultant output gases is used for power generation. The wastes covered under this methodology are municipal solid waste (MSW), biomass residues and tyres.</p>
<p>Type of GHG emissions mitigation action</p>	<ul style="list-style-type: none"> • GHG emission avoidance • Renewable energy <p>CH₄ emissions due to anaerobic decay of MSW and biomass residues are avoided by alternative waste treatment process. Tyres, biomass residues and MSW account for renewable energy.</p>
<p>Important conditions under which the methodology is applicable</p>	<ul style="list-style-type: none"> • The project activity involves the construction of a new plant to implement CRD technology for waste treatment; • The co-products (e.g. syn gas, carbon char, emulsion fuel, fuel oil grade 2-4 etc.) of the CRD technology should be used within the project boundary; • When tyres are used as waste, only End of Life Tyres (ELT) should be used; • Neither waste nor products and by-products from the waste treatment plant established under the project activity are stored on-site under anaerobic conditions; • The project does not reduce the amount of waste that would be recycled in the absence of the project activity.
<p>Important parameters</p>	<p>At validation:</p> <ul style="list-style-type: none"> • Source of end of life tyres; • Source of MSW. <p>Monitored:</p> <ul style="list-style-type: none"> • Weight fraction of the different waste types in a sample and total amount of organic waste prevented from disposal; • Stack gas analysis; • Electricity and fossil fuel consumption in the project site; • Electricity generated by the project activity.
<p>BASELINE SCENARIO Disposal of the waste in a landfill site without capturing landfill gas, electricity is generated by the grid.</p>	
<p>PROJECT SCENARIO Continuous reductive distillation technology is used to treat the waste. Electricity is generated as final product.</p>	

AM0113 Distribution of compact fluorescent lamps (CFL) and light-emitting diode (LED) lamps to households



<p>Typical project(s)</p>	<p>Self-ballasted compact fluorescent lamps (CFLs) and light-emitting diode (LED) lamps are sold or distributed to households to replace less efficient lamps (e.g. incandescent lamps) in households.</p>
<p>Type of GHG emissions mitigation action</p>	<ul style="list-style-type: none"> • Energy efficiency. <p>Displacement of less-efficient lighting by a more-efficient technology.</p>
<p>Important conditions under which the methodology is applicable</p>	<ul style="list-style-type: none"> • Baseline lamps replaced by the project meet the national/local lighting performance standards; • Lumen output of a project lamp shall be equal to or more than that of the baseline lamp being replaced; • Project lamps shall be marked.
<p>Important parameters</p>	<p>At validation:</p> <ul style="list-style-type: none"> • Rated average life of each type of project lamp.
	<p>Monitored:</p> <ul style="list-style-type: none"> • Failure rate of each type of lamp; • Scrapping/destruction of replaced baseline lamps.
<p>BASELINE SCENARIO Less-energy-efficient light bulbs are used in households resulting in higher electricity demand.</p>	
<p>PROJECT SCENARIO More-energy-efficient lamps are used in households saving electricity and thus reducing GHG emissions.</p>	

AM0114 Shift from electrolytic to catalytic process for recycling of chlorine from hydrogen chloride gas in isocyanate plants

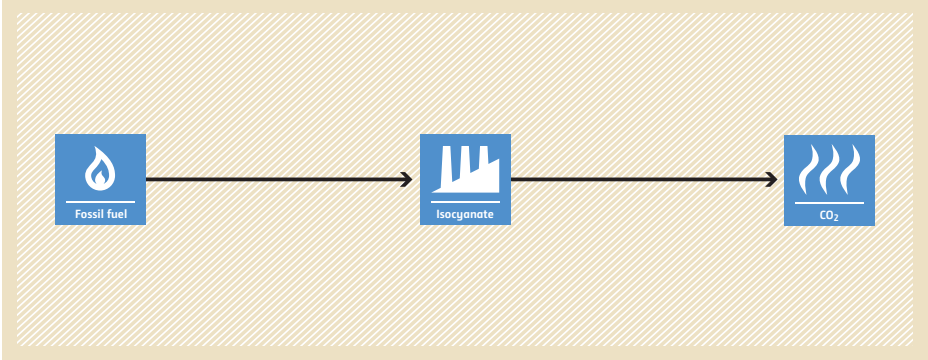
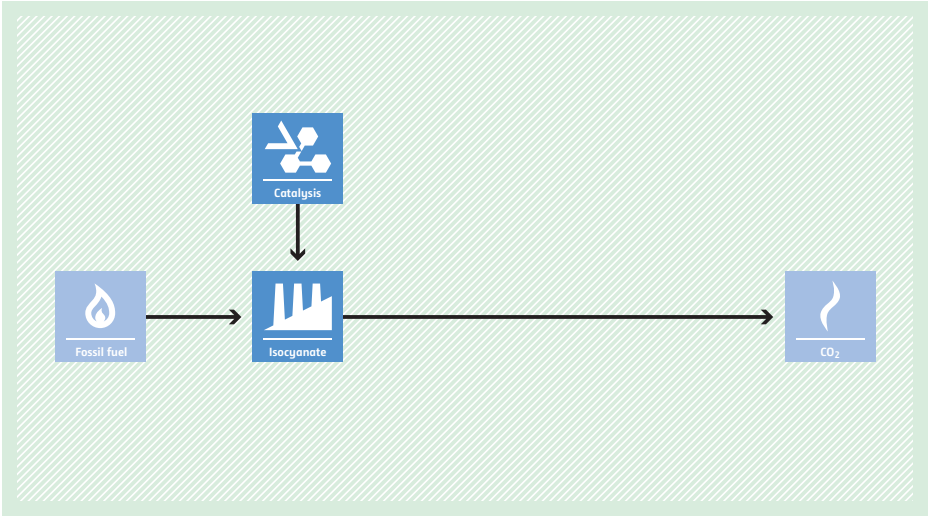
Typical project(s)	Project activities where electrolytic process is replaced by catalytic process for the recycling of chlorine (Cl_2) from hydrogen chloride (HCl) gas in isocyanate plant.
Type of GHG emissions mitigation action	<ul style="list-style-type: none"> • Energy efficiency. Reduction in electricity consumption and displacement of production of electricity by fossil fuel.
Important conditions under which the methodology is applicable	<ul style="list-style-type: none"> • Not applicable to project activities taking place in Greenfield isocyanate plants; • The isocyanate plant, the Cl_2 plant and the electrolytic recycling facilities have operational history of at least three years prior to the starting date of the CDM project activity; • Project activities where the production ratio of HCl to isocyanate in the crediting period shall not change by more than +/-10 per cent compared to the maximum ratio of the three years of the baseline.
Important parameters	At validation: <ul style="list-style-type: none"> • Amount and quality of HCl and isocyanate used in the baseline; • Amount of electricity consumed for the production of recycled Cl_2 in baseline.
	Monitored: <ul style="list-style-type: none"> • Amount and quality of HCl, Cl_2 and isocyanate in the project scenario.
BASELINE SCENARIO Continuation of current practices, i.e. continued use of electrolytic process to recycle Cl_2 from the HCl gas in isocyanate plant.	 <p>The baseline scenario flowchart shows a linear process. It starts with a box labeled 'Fossil fuel' with a flame icon. An arrow points to a box labeled 'Isocyanate' with a factory icon. A second arrow points to a box labeled 'CO₂' with a flame icon. The entire flowchart is set against a light orange background with a diagonal hatching pattern.</p>
PROJECT SCENARIO Catalytic process for the recycling of Cl_2 from HCl gas in isocyanate plant.	 <p>The project scenario flowchart shows a process where fossil fuel is used to produce isocyanate, which then undergoes catalysis to produce recycled chlorine. The flowchart starts with a box labeled 'Fossil fuel' with a flame icon. An arrow points to a box labeled 'Isocyanate' with a factory icon. Above the 'Isocyanate' box is a box labeled 'Catalysis' with a molecular icon, and an arrow points down from it to the 'Isocyanate' box. A second arrow points from the 'Isocyanate' box to a box labeled 'CO₂' with a flame icon. The entire flowchart is set against a light green background with a diagonal hatching pattern.</p>



ACM0001 Flaring or use of landfill gas

<p>Typical project(s)</p>	<p>Capture of landfill gas (LFG) and its flaring and/or use to produce energy and/or use to supply consumers through natural gas distribution network or trucks.</p>
<p>Type of GHG emissions mitigation action</p>	<ul style="list-style-type: none"> • GHG destruction. <p>Destruction of methane emissions and displacement of a more-GHG-intensive service.</p>
<p>Important conditions under which the methodology is applicable</p>	<ul style="list-style-type: none"> • Captured landfill gas is flared, and/or; • Captured landfill gas is used to produce energy, and or; • Captured gas is used to supply consumers through natural gas distribution network or trucks.
<p>Important parameters</p>	<p>Monitored:</p> <ul style="list-style-type: none"> • Amount of landfill gas captured; • Methane fraction in the landfill gas; • If applicable: electricity generation using landfill gas.
<p>BASELINE SCENARIO LFG from the landfill site is released to the atmosphere.</p>	
<p>PROJECT SCENARIO LFG from the landfill site is captured and flared; and/or used to produce energy (e.g. electricity/thermal energy); and/or used to supply consumers through natural gas distribution network.</p>	

ACM0002 Grid-connected electricity generation from renewable sources



<p>Typical project(s)</p>	<p>Retrofit, rehabilitation (or refurbishment), replacement or capacity addition of an existing power plant or construction and operation of a new power plant/unit that uses renewable energy sources and supplies electricity to the grid.</p>
<p>Type of GHG emissions mitigation action</p>	<ul style="list-style-type: none"> • Renewable energy. <p>Displacement of electricity that would be provided to the grid by more-GHG-intensive means.</p>
<p>Important conditions under which the methodology is applicable</p>	<ul style="list-style-type: none"> • The project power plant is using one of the following sources: hydro, wind, geothermal, solar, wave or tidal power. Biomass-fired power plants are not applicable; • In the case of capacity additions, retrofits, rehabilitation or replacements, the existing power plant started commercial operation prior to the start of a minimum historical reference period of five years, and no capacity expansion or retrofit, rehabilitation or replacement of the plant has been undertaken between the start of this minimum historical reference period and the implementation of the project; • In case of hydro power: <ul style="list-style-type: none"> • The project has to be implemented in an existing reservoir, with no change in the volume of reservoir; • The project has to be implemented in an existing reservoir, where the volume of reservoir is increased and the power density is greater than 4 W/m²; • The project results in new reservoirs and the power density is greater than 4 W/m²; or • The project activity is an integrated hydro power project involving multiple reservoirs.
<p>Important parameters</p>	<p>At validation:</p> <ul style="list-style-type: none"> • Grid emission factor (can also be monitored ex post). <p>Monitored:</p> <ul style="list-style-type: none"> • Electricity supplied to the grid by the project; • If applicable: methane emissions of the project.
<p>BASELINE SCENARIO Electricity provided to the grid by more-GHG-intensive means.</p>	<pre> graph LR FF[Fossil fuel] --> G[Grid] G --> E1[Electricity] G --> E2[Electricity] G --> CO2[CO2] E1 --> E3[Electricity] E2 --> E3 </pre>
<p>PROJECT SCENARIO Displacement of electricity provided to the grid by more-GHG-intensive means by installation of a new renewable power plant or the retrofit, replacement or capacity addition of an existing renewable power plant.</p>	<pre> graph LR FF[Fossil fuel] --> G[Grid] R[Renewable] --> E1[Electricity] G --> E2[Electricity] G --> CO2[CO2] E1 --> E3[Electricity] E2 --> E3 </pre>

ACM0003 Emissions reduction through partial substitution of fossil fuels with alternative fuels or less carbon intensive fuels in cement or quicklime manufacture

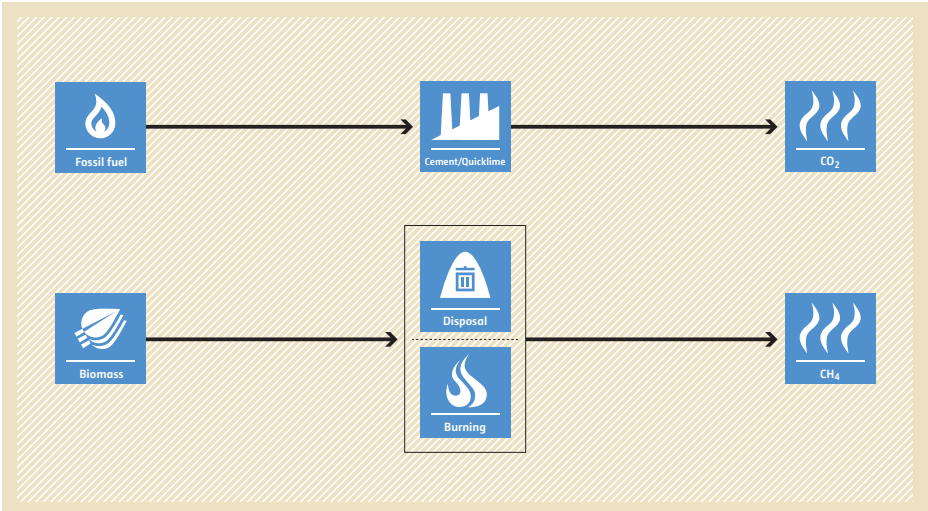
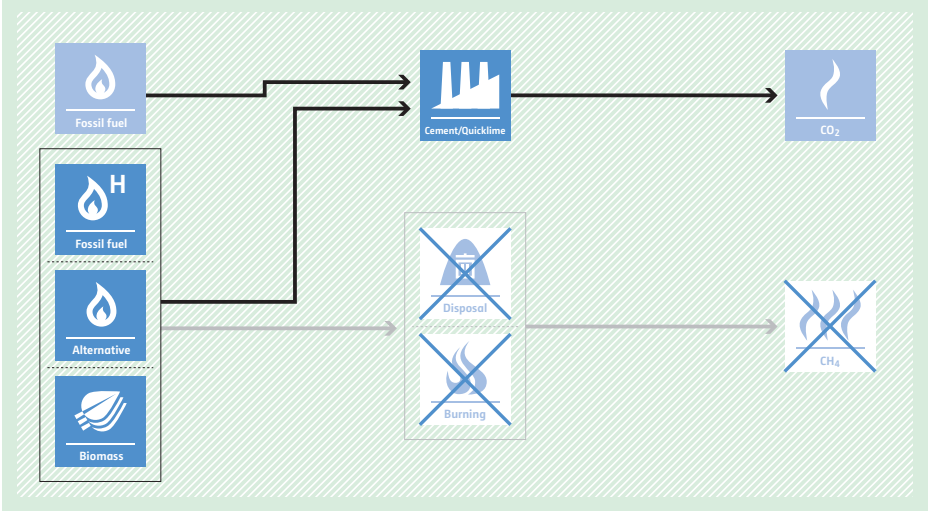
<p>Typical project(s)</p>	<p>Partial replacement of fossil fuels in an existing clinker or quicklime production facility by less-carbon-intensive fossil fuel or alternative fuel (e.g. wastes or biomass residues).</p>
<p>Type of GHG emissions mitigation action</p>	<ul style="list-style-type: none"> • Fuel switch; • Renewable energy. <p>Reduction of GHG emissions by switching from carbon-intensive fuel to less-carbon-intensive or alternative fuel; GHG emission avoidance by preventing disposal or uncontrolled burning of biomass residues.</p>
<p>Important conditions under which the methodology is applicable</p>	<ul style="list-style-type: none"> • No alternative fuels have been used in the project facility during the last three years prior to the start of the project; • The biomass to be combusted should not have been processed chemically; • For biomass from dedicated plantations, specific conditions apply.
<p>Important parameters</p>	<p>Monitored:</p> <ul style="list-style-type: none"> • Quantity and net calorific value of alternative fuel and/or less-carbon-intensive fossil fuel used in the project plant; • Quantity of clinker or quicklime produced.
<p>BASELINE SCENARIO Clinker or quicklime is produced using more-carbon-intensive fuel and/or decay or uncontrolled burning of biomass leads to CH₄ emissions.</p>	 <p>The baseline scenario flowchart is set against a light brown background. It shows two parallel paths. The top path starts with a 'Fossil fuel' icon (flame) pointing to a 'Cement/Quicklime' icon (factory), which then points to a 'CO₂' icon (flames). The bottom path starts with a 'Biomass' icon (leaves) pointing to a box containing two icons: 'Disposal' (trash can) and 'Burning' (flame). This box points to a 'CH₄' icon (flames).</p>
<p>PROJECT SCENARIO Clinker or quicklime is produced using less-carbon-intensive fuel and/or alternative fuel and/or biomass is combusted.</p>	 <p>The project scenario flowchart is set against a light green background. It shows a 'Fossil fuel' icon (flame) pointing to a 'Cement/Quicklime' icon (factory), which points to a 'CO₂' icon (flames). To the left of the factory, there is a vertical stack of three icons: 'Fossil fuel' (flame), 'Alternative' (flame), and 'Biomass' (leaves). Arrows from the 'Alternative' and 'Biomass' icons point to the factory. Below the factory, there is a box containing three crossed-out icons: 'Disposal' (trash can), 'Burning' (flame), and 'CH₄' (flames). An arrow from the 'Biomass' icon points to this crossed-out box.</p>

ACM0005 Increasing the blend in cement production

Typical project(s)	Use of blending material (e.g. fly ash, gypsum, slag) to decrease the share of clinker in cement.
Type of GHG emissions mitigation action	<ul style="list-style-type: none"> • Feedstock switch. CO ₂ emissions from clinker production are avoided due to less use of clinker.
Important conditions under which the methodology is applicable	<ul style="list-style-type: none"> • Applicable to domestically sold blended cement; • Not applicable if blending of cement outside the cement production plant is common in the host country; • Not applicable for grinding only plants.
Important parameters	At validation: <ul style="list-style-type: none"> • Clinker ratio at the project plant, clinker ratio at all other plants in the region and in the five highest blended cement brands in the region; • Electricity emission factor. Monitored: <ul style="list-style-type: none"> • Cement and clinker production; • Raw materials, electricity demand and fuel use in the production of clinker; • Clinker and additives use in the production of cement.

BASILINE SCENARIO

Available blending material is not used. Cement is produced with high clinker content, leading to high CO₂ emissions.

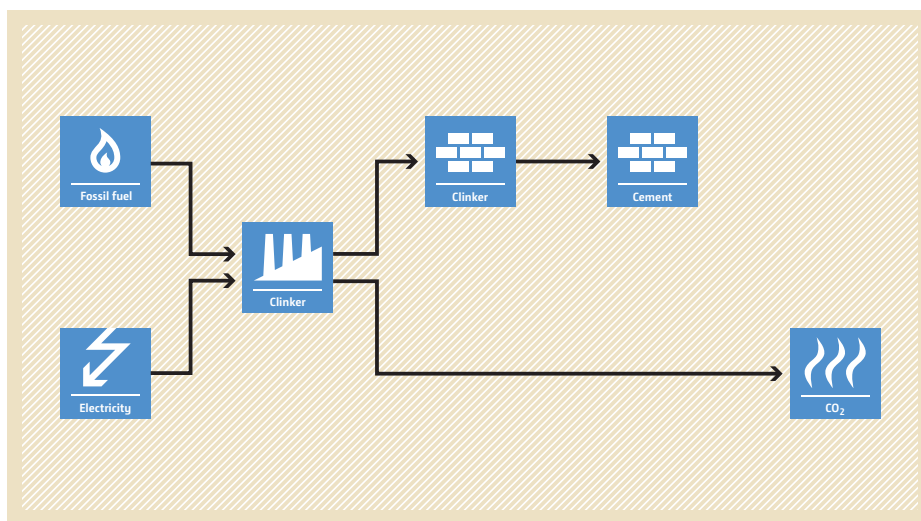

PROJECT SCENARIO

Available blending material is used in cement to partially replace clinker. Thereby CO₂ emissions from clinker production are avoided.

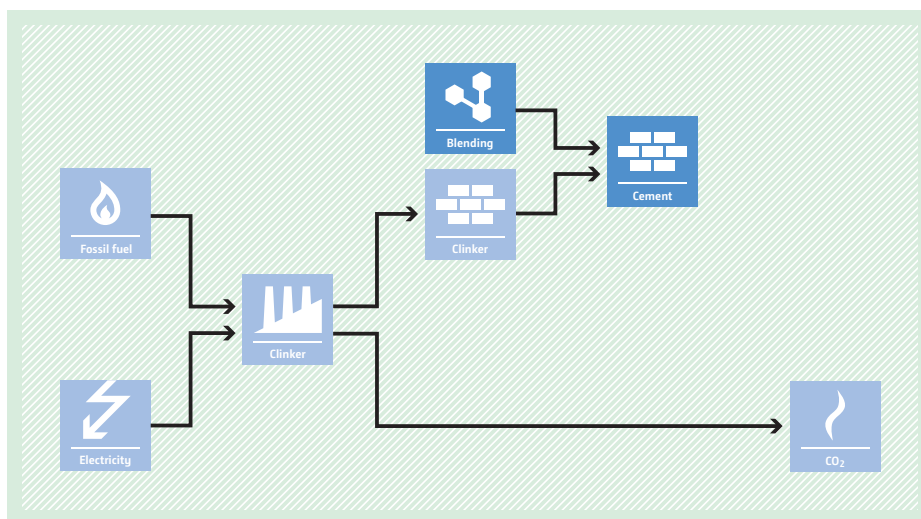

ACM0006 Electricity and heat generation from biomass

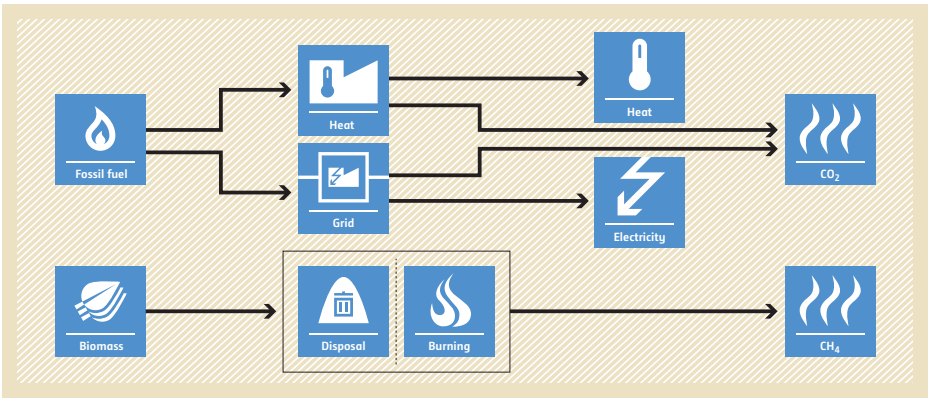
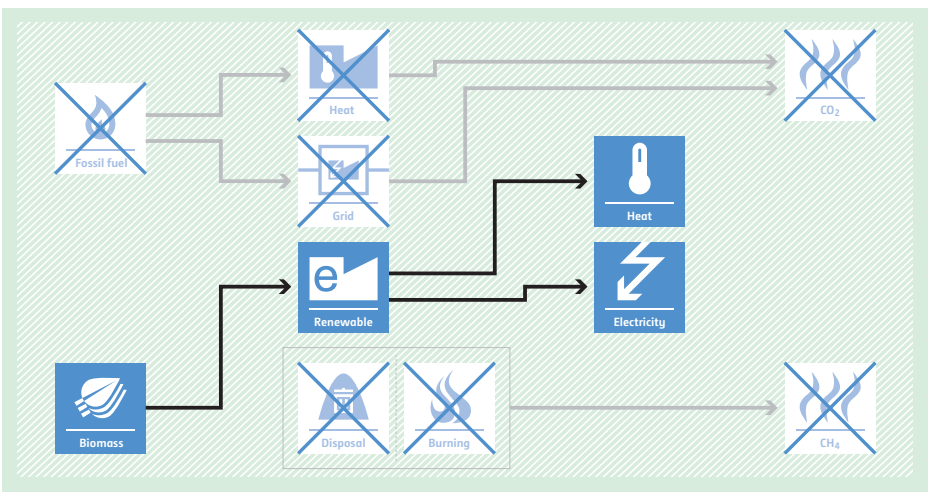
<p>Typical project(s)</p>	<p>Generation of power and heat in thermal power plants, including cogeneration plants using biomass. Typical activities are new plant, capacity expansion, energy efficiency improvements or fuel switch projects.</p>
<p>Type of GHG emissions mitigation action</p>	<ul style="list-style-type: none"> • Renewable energy; • Energy efficiency; • Fuel switch; • GHG emission avoidance. <p>Displacement of more-GHG-intensive electricity generation in grid or heat and electricity generation on-site. Avoidance of methane emissions from anaerobic decay of biomass residues.</p>
<p>Important conditions under which the methodology is applicable</p>	<ul style="list-style-type: none"> • Only power and heat or cogeneration plants are applicable; • Only biomass residues and biomass from dedicated plantations are eligible; • Fossil fuels may be co-fired in the project plant. The amount of fossil fuels co-fired shall not exceed 80% of the total fuel fired on an energy basis; • In case of biomass from dedicated plantations, the plantations are established either on land that was classified as degraded or degrading or that is included in the project boundary of a registered A/R project activity.
<p>Important parameters</p>	<p>At validation:</p> <ul style="list-style-type: none"> • Grid emission factor (can also be monitored ex post). <p>Monitored:</p> <ul style="list-style-type: none"> • Quantity and moisture content of the biomass used in the project activity; • Electricity and heat generated in the project activity; • Electricity and, if applicable, fossil fuel consumption of the project activity.
<p>BASELINE SCENARIO Electricity and heat would be produced by more-carbon-intensive technologies based on fossil fuel or less-efficient biomass power and heat plants. Biomass could partly decay under anaerobic conditions, bringing about methane emissions.</p>	 <p>The baseline scenario flowchart shows fossil fuel and biomass as inputs. Fossil fuel feeds into Heat and Grid. Biomass feeds into Disposal and Burning. Heat and Grid feed into Heat and Electricity. Disposal and Burning feed into CH4. Heat and Electricity feed into CO2. CH4 also feeds into CO2.</p>
<p>PROJECT SCENARIO Use of biomass for power and heat generation instead of fossil fuel or increase of the efficiency of biomass-fuelled power and heat plants. Biomass is used as fuel and decay of biomass is avoided.</p>	 <p>The project scenario flowchart shows biomass as the primary input, displacing fossil fuel. Biomass feeds into Renewable, Disposal, and Burning. Renewable feeds into Heat and Electricity. Disposal and Burning feed into CH4. Heat and Electricity feed into CO2. CH4 also feeds into CO2. Fossil fuel, Heat, Grid, and Disposal/Burning are crossed out with red X's, indicating they are avoided or displaced.</p>

ACM0007 Conversion from single cycle to combined cycle power generation

Typical project(s)	Conversion from an open-cycle gas power plant to a combined-cycle gas power plant.
Type of GHG emissions mitigation action	<ul style="list-style-type: none"> • Energy efficiency. • Fuel savings through energy efficiency improvement.
Important conditions under which the methodology is applicable	<ul style="list-style-type: none"> • The project does not increase the lifetime of the existing gas turbine or engine during the crediting period; • Waste heat generated on the project site is not utilizable for any other purpose.
Important parameters	<p>At validation:</p> <ul style="list-style-type: none"> • Electricity generation of the existing open-cycle gas power plant (can also be monitored ex post); • Fuel consumption of the existing open-cycle gas power plant. <hr/> <p>Monitored:</p> <ul style="list-style-type: none"> • Electricity generation of the combined-cycle gas power plant; • Fuel consumption of the combined-cycle gas power plant; • Grid emission factor.
BASELINE SCENARIO Electricity is generated by an open-cycle gas power plant.	
PROJECT SCENARIO The open-cycle gas power plant is converted to a combined-cycle one for more-efficient power generation.	

ACM0008 Abatement of methane from coal mines

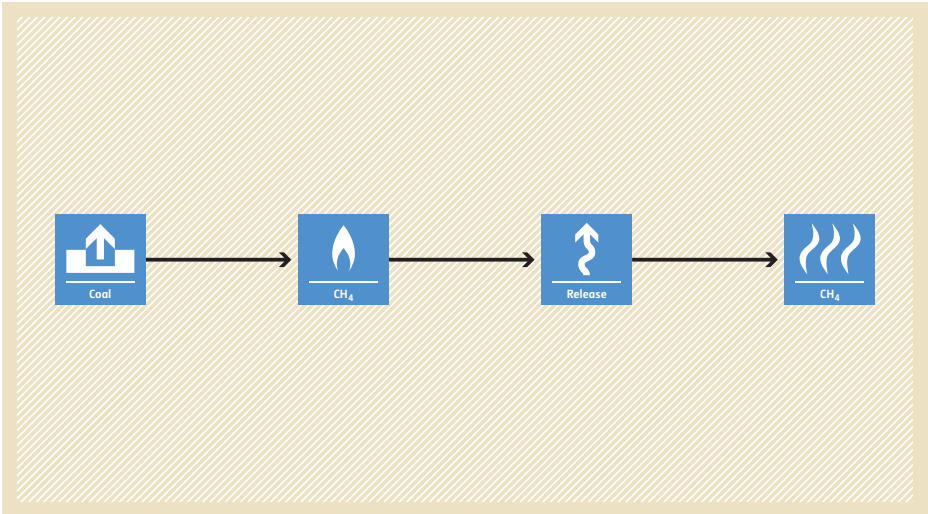
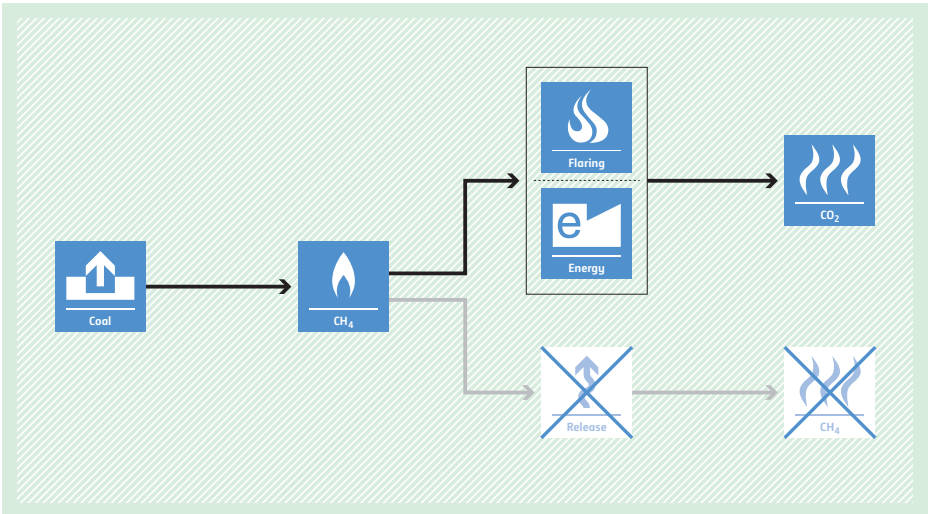
<p>Typical project(s)</p>	<p>Capture and destruction and/or use of coal bed methane, coal mine methane or ventilation air methane from new, existing or abandoned coal mine(s).</p>
<p>Type of GHG emissions mitigation action</p>	<ul style="list-style-type: none"> • GHG destruction. <p>Destruction of methane emissions and displacement of more-GHG-intensive service.</p>
<p>Important conditions under which the methodology is applicable</p>	<ul style="list-style-type: none"> • All methane captured by the project should either be used or destroyed; • Not applicable to capture/use of virgin coal bed methane, e.g. methane extracted from coal seams for which there is no valid coal mining concession; • Not applicable to methane extraction from abandoned mines that are flooded due to regulation.
<p>Important parameters</p>	<p>Monitored:</p> <ul style="list-style-type: none"> • Methane destroyed or used; • Concentration of methane in extracted gas; • If applicable: electricity generated by project;
<p>BASELINE SCENARIO Methane from coal mining activities is vented into the atmosphere.</p>	 <p>The baseline scenario flowchart shows a linear process: 'Coal' (represented by a mine icon) leads to 'CH₄' (represented by a flame icon), which then leads to 'Release' (represented by an upward arrow icon), and finally to 'CH₄' (represented by a flame icon) being emitted into the atmosphere.</p>
<p>PROJECT SCENARIO Methane from coal mining activities is captured and destroyed using oxidation or used for power or heat generation.</p>	 <p>The project scenario flowchart shows a linear process: 'Coal' (represented by a mine icon) leads to 'CH₄' (represented by a flame icon). From this 'CH₄' node, two paths emerge: one leading to a box containing 'Flaring' (flame icon) and 'Energy' (e icon), which then leads to 'CO₂' (flame icon); the other path leads to a 'Release' icon (upward arrow) that is crossed out with a large 'X', which then leads to a 'CH₄' icon also crossed out with a large 'X', indicating that methane release is prevented.</p>

ACM0009 Fuel switching from coal or petroleum fuel to natural gas

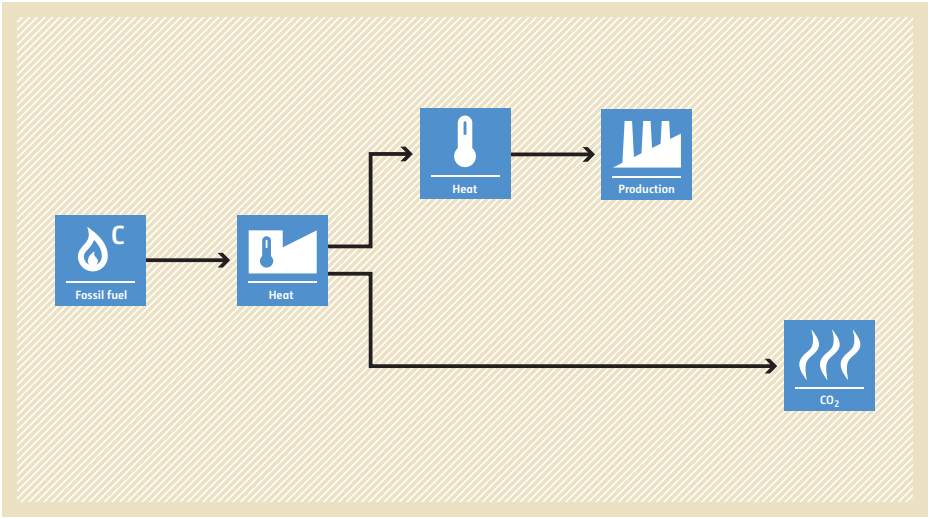
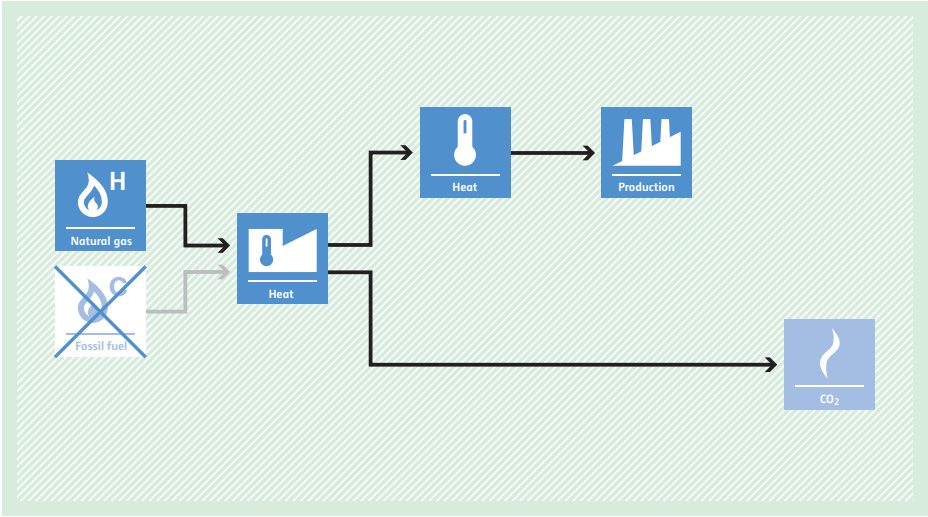
<p>Typical project(s)</p>	<p>Switching from coal or petroleum fuel to natural gas in the generation of heat for industrial processes.</p>
<p>Type of GHG emissions mitigation action</p>	<ul style="list-style-type: none"> • Fuel switch. <p>Reduction of GHG emissions by switching from carbon-intensive to a less-carbon-intensive fuel in the generation of heat.</p>
<p>Important conditions under which the methodology is applicable</p>	<ul style="list-style-type: none"> • No natural gas has previously been used; • The fuel is neither used for cogeneration of electricity nor as an oxidant but generates heat for district heating or an industrial output other than heat; • The project does not increase the capacity of thermal output or lifetime of the element processes or does not result in integrated process change.
<p>Important parameters</p>	<p>At validation:</p> <ul style="list-style-type: none"> • Quantity, net calorific value and CO₂ emission factor of baseline fuels; • Energy efficiency of the element process(es) fired with coal or petroleum fuel. <p>Monitored:</p> <ul style="list-style-type: none"> • Quantity, net calorific value and CO₂ emission factor of natural gas combusted in the element process(es) in the project; • Energy efficiency of the element process(es) if fired with natural gas.
<p>BASELINE SCENARIO Coal or petroleum fuel is used to generate heat.</p>	 <p>The diagram illustrates the baseline scenario. It starts with a box labeled 'Fossil fuel' with a flame icon and a 'C' (representing carbon). An arrow points to a 'Heat' box with a thermometer icon. From this 'Heat' box, two arrows branch out: one points to another 'Heat' box with a thermometer icon, which then points to a 'Production' box with a factory icon; the other arrow points directly to a 'CO₂' box with a flame icon.</p>
<p>PROJECT SCENARIO Natural gas replaces coal or petroleum fuel</p>	 <p>The diagram illustrates the project scenario. It shows 'Natural gas' (flame icon with 'H') and 'Fossil fuel' (flame icon with 'C' and a blue 'X' over it) both pointing to a 'Heat' box (thermometer icon). From this 'Heat' box, two arrows branch out: one points to another 'Heat' box (thermometer icon) which then points to a 'Production' box (factory icon); the other arrow points to a 'CO₂' box (flame icon).</p>

ACM0010 GHG emission reductions from manure management systems

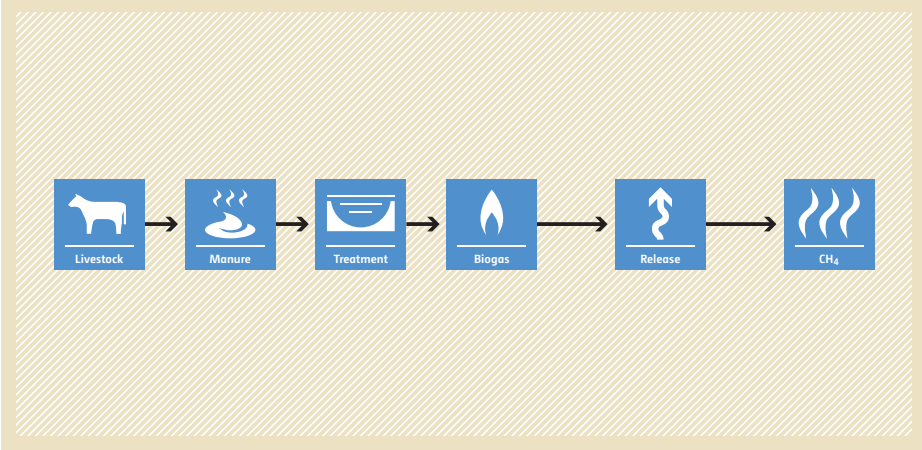
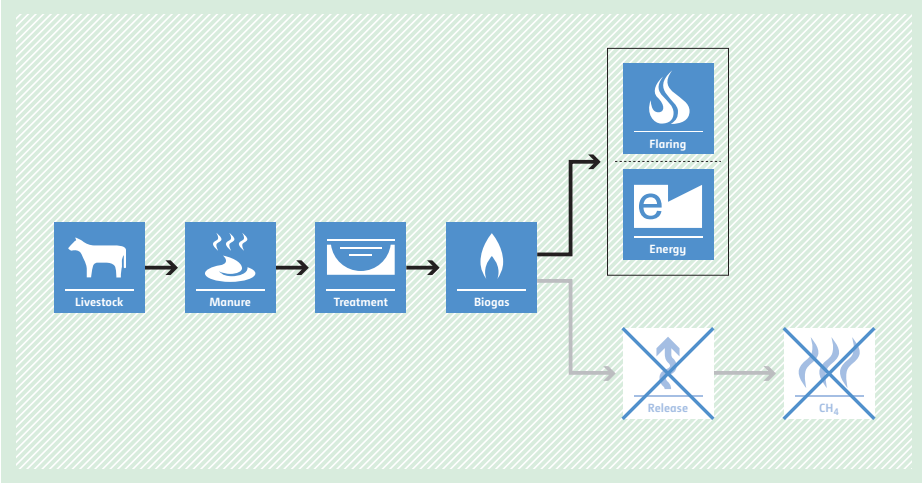
<p>Typical project(s)</p>	<p>Manure management on livestock farms (cattle, buffalo, swine, sheep, goats, and/or poultry) where the existing anaerobic manure treatment system is replaced by, or a new system is constructed as, one or a combination of more than one animal waste management systems that result in less GHG emissions.</p>
<p>Type of GHG emissions mitigation action</p>	<ul style="list-style-type: none"> • GHG destruction. <p>Destruction of methane emissions and displacement of a more-GHG-intensive service.</p>
<p>Important conditions under which the methodology is applicable</p>	<ul style="list-style-type: none"> • Farms where livestock populations are managed under confined conditions; • Farms where manure is not discharged into natural water resources (e.g. rivers or estuaries); • In case of anaerobic lagoon treatment systems, the depth of the lagoons used for manure management under the baseline scenario should be at least 1 m; • The annual average ambient temperature at the treatment site is higher than 5°C; • In the baseline case, the minimum retention time of manure waste in the anaerobic treatment system is greater than one month.
<p>Important parameters</p>	<p>Monitored:</p> <ul style="list-style-type: none"> • Number of heads of each population and the average animal weight in each population; • If dietary intake method is used, daily average gross energy intake has to be monitored; • Electricity and fossil fuel consumption.
<p>BASELINE SCENARIO Existing manure management system or system to be installed in the absence of the project activity results in release of methane into the atmosphere.</p>	 <p>The diagram illustrates the baseline scenario for manure management. It shows a linear process starting with 'Livestock' (represented by a cow icon), which produces 'Manure' (represented by a pile of manure icon). The manure undergoes 'Treatment' (represented by a lagoon icon), producing 'Biogas' (represented by a flame icon). From the Biogas stage, the process branches into two paths: one leading to 'Release' (represented by an upward arrow icon) and another leading to 'CH4' (represented by a flame icon). Both the 'Release' and 'CH4' boxes are crossed out with a large 'X', indicating that methane is not released into the atmosphere in this scenario.</p>
<p>PROJECT SCENARIO Capture of methane in the animal waste management systems results in less GHG emissions. In case of energetic use of methane, displacement of more-GHG-intensive energy generation.</p>	 <p>The diagram illustrates the project scenario for manure management. It shows a linear process starting with 'Livestock' (represented by a cow icon), which produces 'Manure' (represented by a pile of manure icon). The manure undergoes 'Treatment' (represented by a lagoon icon), producing 'Biogas' (represented by a flame icon). From the Biogas stage, the process branches into two paths: one leading to 'Flaring' (represented by a flame icon) and another leading to 'Release' (represented by an upward arrow icon). The 'Flaring' box is crossed out with a large 'X', indicating that methane is not released into the atmosphere. The 'Release' and 'CH4' boxes are also crossed out with a large 'X', indicating that methane is not released into the atmosphere. The 'Flaring' box is labeled 'Energy' below it, indicating that the methane is used for energy generation.</p>

ACM0011 Consolidated baseline methodology for fuel switching from coal and/or petroleum fuels to natural gas in existing power plants for electricity generation

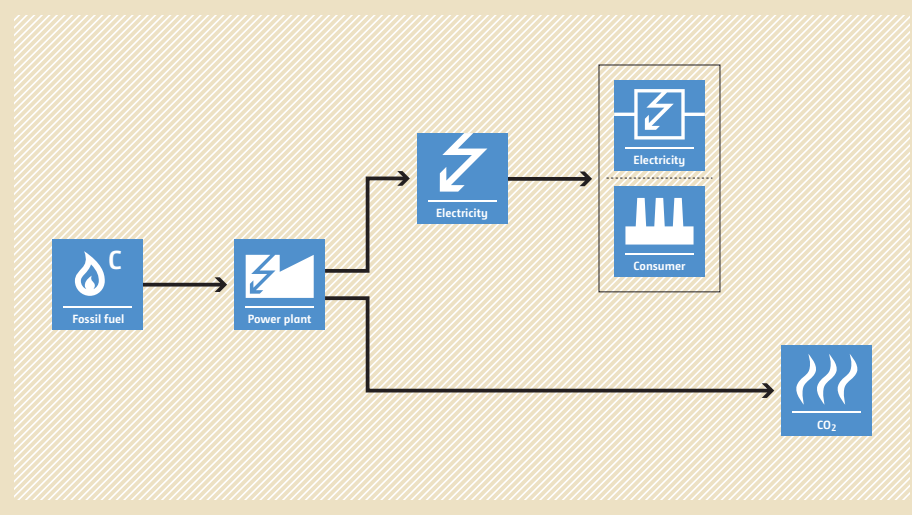
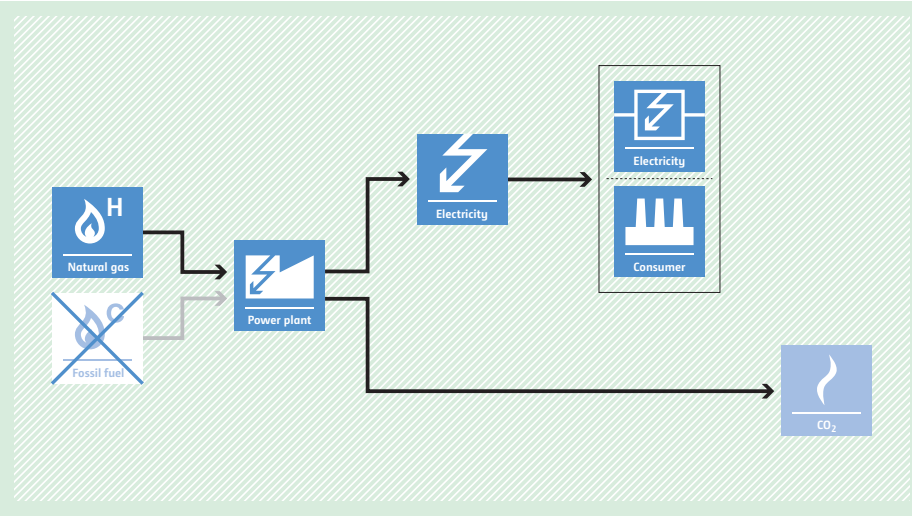
Typical project(s)	Switch from coal or petroleum derived fuel to natural gas at an existing power plant.
Type of GHG emissions mitigation action	<ul style="list-style-type: none"> Fuel switch. Switch from coal or petroleum fuel to natural gas.
Important conditions under which the methodology is applicable	<ul style="list-style-type: none"> At least three years of operation history are available; The fuel switch is from only coal and/or petroleum fuels to only natural gas; Only power is generated, for either only the grid or only a captive consumer; The project does not involve major retrofits/modifications of the power plant.
Important parameters	At validation: <ul style="list-style-type: none"> Historical fuel consumption and power generation; Electricity emission factor (can also be monitored ex post). <hr/> Monitored: <ul style="list-style-type: none"> Quantity, calorific value and emission factor of fuels consumed in the project; Electricity supplied to the electric power grid or consuming facility.
BASELINE SCENARIO Coal and/or petroleum fuel is used to generate electricity.	 <p>The diagram illustrates the baseline scenario. On the left, a box labeled 'Fossil fuel' with a flame icon and a 'C' superscript is connected by an arrow to a 'Power plant' box with a lightning bolt icon. From the power plant, two arrows branch out: one goes to a box labeled 'Electricity' with a lightning bolt icon, which then points to a larger box containing 'Electricity' (lightning bolt) and 'Consumer' (factory icon); the other arrow goes to a box labeled 'CO2' with a flame icon.</p>
PROJECT SCENARIO Natural gas is used to generate electricity.	 <p>The diagram illustrates the project scenario. On the left, a box labeled 'Natural gas' with a flame icon and an 'H' superscript is connected by an arrow to a 'Power plant' box with a lightning bolt icon. A box labeled 'Fossil fuel' with a flame icon and a 'C' superscript is crossed out with a large 'X' and has a faded arrow pointing towards the power plant. From the power plant, two arrows branch out: one goes to a box labeled 'Electricity' with a lightning bolt icon, which then points to a larger box containing 'Electricity' (lightning bolt) and 'Consumer' (factory icon); the other arrow goes to a box labeled 'CO2' with a flame icon.</p>

ACM0012 Consolidated baseline methodology for GHG emission reductions from waste energy recovery projects

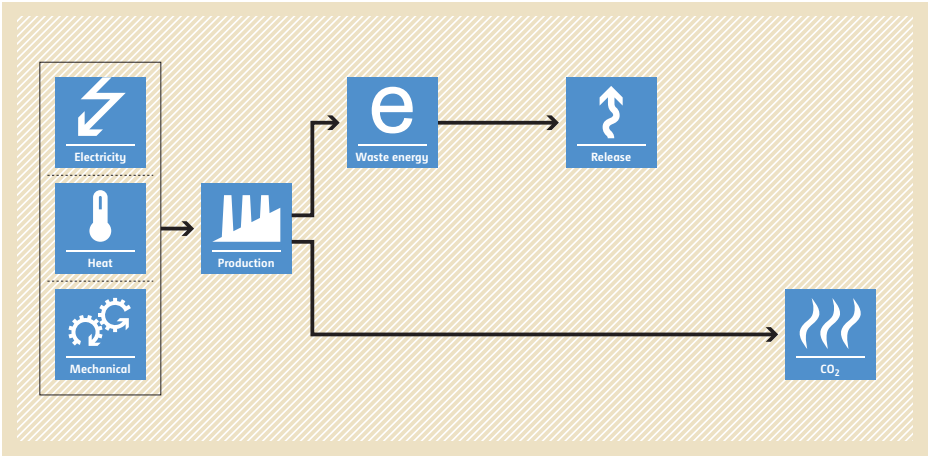
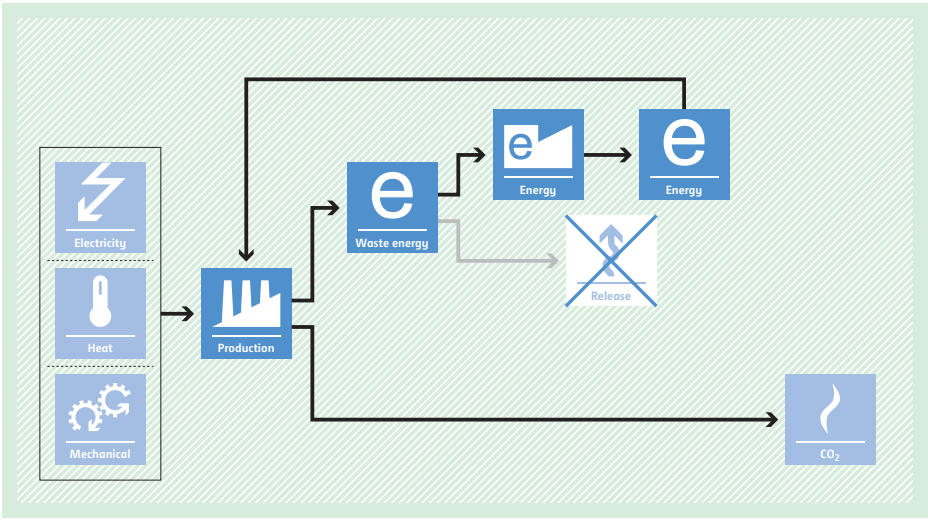
<p>Typical project(s)</p>	<p>Energy from waste heat, waste gas or waste pressure in an existing or new industrial facility is recovered and used for in-house consumption or for export, by installation of a new power and/or heat and/or mechanical energy generation equipment, or by installation of a more-efficient electricity generation equipment than already existing.</p>
<p>Type of GHG emissions mitigation action</p>	<ul style="list-style-type: none"> • Energy efficiency. <p>Waste energy recovery in order to displace more-carbon-intensive energy/technology.</p>
<p>Important conditions under which the methodology is applicable</p>	<ul style="list-style-type: none"> • In the absence of the project, all waste energy would be flared or released into the atmosphere. In case of partial use of the waste energy in the baseline situation, the project increases the share of used waste energy; • For capacity expansion projects, the new capacity should be treated as new facility and therefore the applicable guidance for baseline scenario determination, capping of baseline emissions and demonstration of use of waste energy in absence of the CDM project, should be followed; • An official agreement is required between the generating facility and the recipient facility of energy generated by project, in case they are different entities.
<p>Important parameters</p>	<p>Monitored:</p> <ul style="list-style-type: none"> • Quantity of electricity/ heat supplied to the recipient plant(s); • Quantity and parameters of waste energy streams during project.
<p>BASILINE SCENARIO Carbon-intensive sources will continue to supply heat/electricity/mechanical energy to the applications of the recipient facility and unrecovered energy from waste energy source will continue to be wasted.</p>	 <p>The diagram illustrates the baseline scenario. On the left, three boxes represent energy sources: Electricity (lightning bolt icon), Heat (thermometer icon), and Mechanical (gears icon). Arrows from these boxes point to a central 'Production' box (factory icon). From the 'Production' box, three arrows branch out: one to a 'Waste energy' box (letter 'e' icon), one to a 'Release' box (upward arrow icon), and one to a 'CO₂' box (flame icon). The 'Waste energy' box has an arrow pointing to the 'Release' box.</p>
<p>PROJECT SCENARIO Heat/electricity/mechanical energy are generated by recovery of energy from a waste energy source and are supplied to the grid an/or applications in the recipient facility.</p>	 <p>The diagram illustrates the project scenario. On the left, the same three energy source boxes (Electricity, Heat, Mechanical) point to the 'Production' box. From 'Production', three arrows branch out: one to a 'Waste energy' box (letter 'e' icon), one to a 'CO₂' box (flame icon), and one to a 'Release' box (upward arrow icon). The 'Waste energy' box has an arrow pointing to an 'Energy' box (letter 'e' icon). This 'Energy' box has an arrow pointing to another 'Energy' box (letter 'e' icon). The 'Release' box is crossed out with a large 'X', indicating that energy is no longer released. The 'CO₂' box remains present.</p>

ACM0013 Construction and operation of new grid connected fossil fuel fired power plants using a less GHG intensive technology

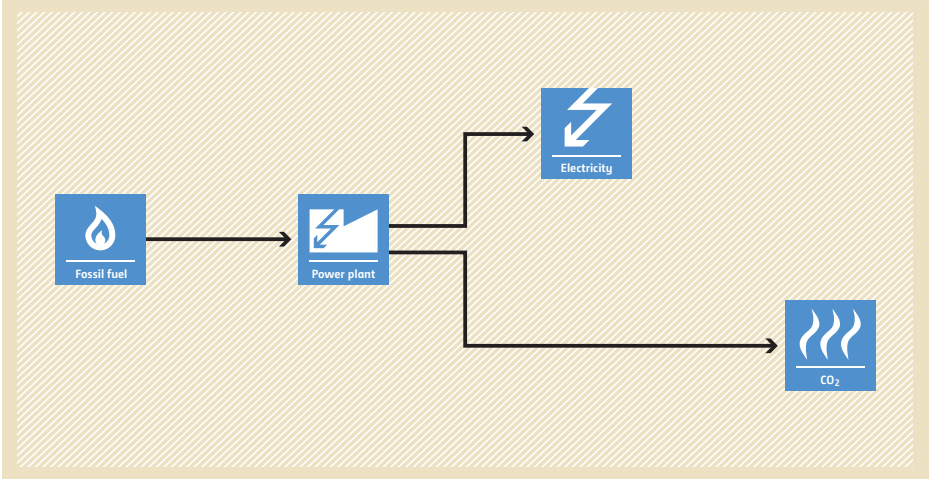
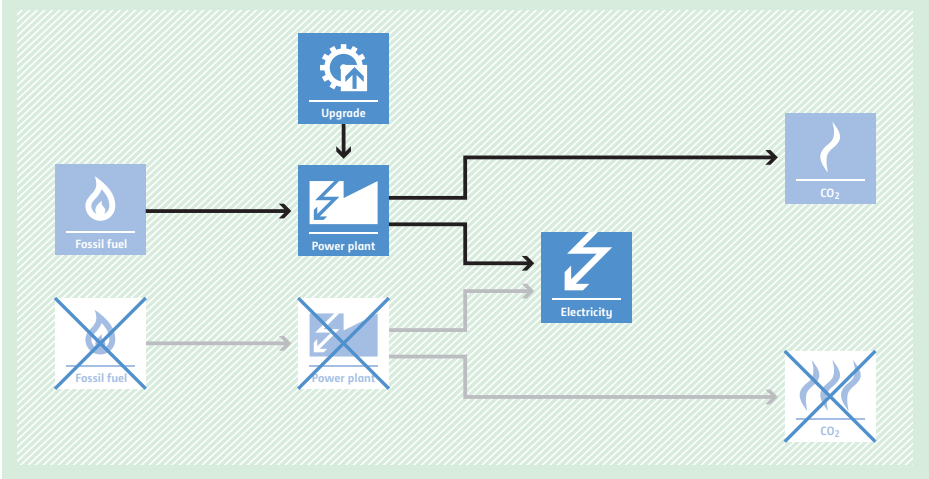
<p>Typical project(s)</p>	<p>Construction and operation of a new fossil fuel fired power plant that supplies electricity to the grid using more-efficient power generation technology than would otherwise be used with the given fossil fuel (e.g. construction of a supercritical coal fired power plant).</p>
<p>Type of GHG emissions mitigation action</p>	<ul style="list-style-type: none"> • Energy efficiency. <p>Construction of a highly efficient new grid-connected fossil-fuel-fired power plant.</p>
<p>Important conditions under which the methodology is applicable</p>	<ul style="list-style-type: none"> • Only supply of power to the grid is applicable (no cogeneration); • The identified baseline fuel category is used as the main fuel category in more than 50% of the total rated capacity of power plants which were commissioned for commercial operation in the most recent five calendar/fiscal years prior to the publication of the PDD for global stakeholder consultation, within the electric grid to which the project plant will be connected; • At least five new power plants can be identified as similar to the project plant (in the baseline identification procedure).
<p>Important parameters</p>	<p>At validation:</p> <ul style="list-style-type: none"> • Energy efficiency of the power generation technology that has been identified as the most likely baseline scenario. <p>Monitored:</p> <ul style="list-style-type: none"> • Quantity, calorific value and emission factor of fuels consumed in the project activity; • Electricity supplied to the electric power grid.
<p>BASELINE SCENARIO Electricity is generated by a less-efficient new grid-connected power plant using fossil fuel.</p>	 <p>The diagram illustrates the baseline scenario. It shows a flow from 'Fossil fuel' (represented by a flame icon) to a 'Power plant' (represented by a lightning bolt icon). From the power plant, two arrows branch out: one to 'Electricity' (lightning bolt icon) and another to 'CO₂' (flame icon).</p>
<p>PROJECT SCENARIO Electricity is generated by a more-efficient new grid-connected power plant using less fossil fuel.</p>	 <p>The diagram illustrates the project scenario. It shows an 'Upgrade' (gear icon) leading to a 'Power plant' (lightning bolt icon). This upgraded power plant receives 'Fossil fuel' (flame icon) and produces 'Electricity' (lightning bolt icon) and 'CO₂' (flame icon). Below this, a crossed-out version of the baseline scenario is shown, indicating that the original, less-efficient power plant and its associated fossil fuel input and CO₂ output are being replaced by the more-efficient project scenario.</p>

ACM0014 Treatment of wastewater

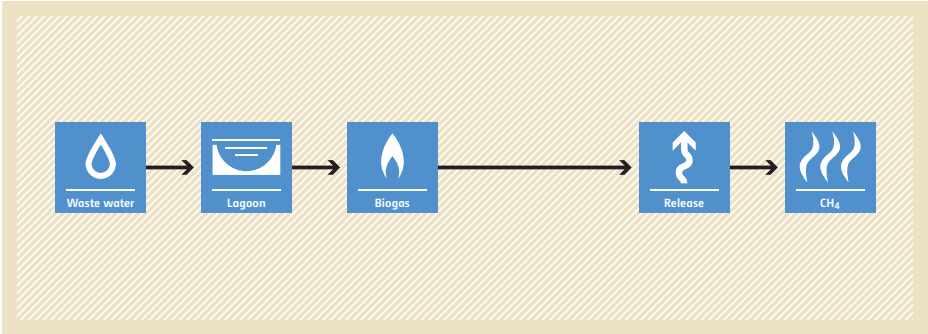
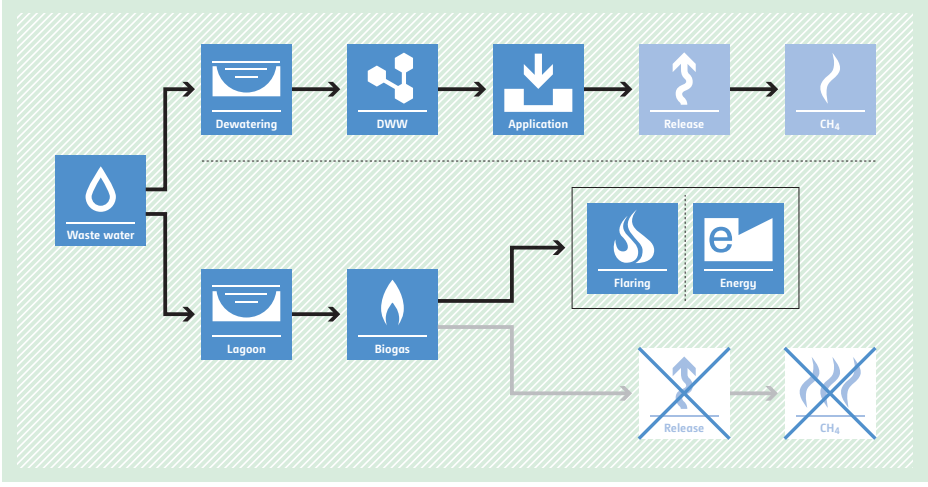
<p>Typical project(s)</p>	<p>Treatment of wastewater in a new anaerobic digester, capture and flaring or utilizing of the generated biogas for electricity or heat generation; Dewatering of wastewater and application to land; Treatment of wastewater in the same treatment plant as in the baseline situation but treatment of the sludge from primary and/or secondary settler either in a new anaerobic digester or treatment of sludge under clearly aerobic conditions.</p>
<p>Type of GHG emissions mitigation action</p>	<ul style="list-style-type: none"> • GHG destruction. <p>Destruction of methane emissions and displacement of more-GHG-intensive service.</p>
<p>Important conditions under which the methodology is applicable</p>	<ul style="list-style-type: none"> • The average depth of the open lagoons or sludge pits in the baseline scenario is at least 1 m; • The residence time of the organic matter in the open lagoon or sludge pit system should be at least 30 days; • Inclusion of solid materials in the project activity is only applicable where: <ul style="list-style-type: none"> (i) Such solid materials are generated by the industrial facility producing the wastewater; and (ii) The solid materials would be generated both in the project and in the baseline scenario; • The sludge produced during the implementation of the project activity is not stored onsite before land application to avoid any possible methane emissions from anaerobic degradation.
<p>Important parameters</p>	<p>Monitored:</p> <ul style="list-style-type: none"> • Quantity and chemical oxygen demand (COD) of wastewater or sludge that is treated in the project; • Quantity of biogas collected and concentration of methane in the biogas; • Net quantity of electricity or heat generated in the project; • Quantity of dewatered sludge/wastewater applied to land.
<p>BASELINE SCENARIO Existing wastewater treatment system results in release of methane into the atmosphere.</p>	 <pre> graph LR A[Waste water] --> B[Lagoon] B --> C[Biogas] C --> D[Release] D --> E[CH4] </pre>
<p>PROJECT SCENARIO Capture of methane in the wastewater treatment system results in less GHG emissions. In case of energetic use of methane, displacement of more-GHG-intensive energy generation. In cases where wastewater is dewatered (DWW) and the output is used for land application less methane is emitted into the atmosphere.</p>	 <pre> graph LR A[Waste water] --> B[Dewatering] A --> C[Lagoon] B --> D[DWW] C --> E[Biogas] D --> F[Application] E --> G[Flaring] E --> H[Energy] F --> I[Release] I --> J[CH4] I --- K[Crossed out] J --- L[Crossed out] </pre>

ACM0015 Emission reductions from raw material switch in clinker production

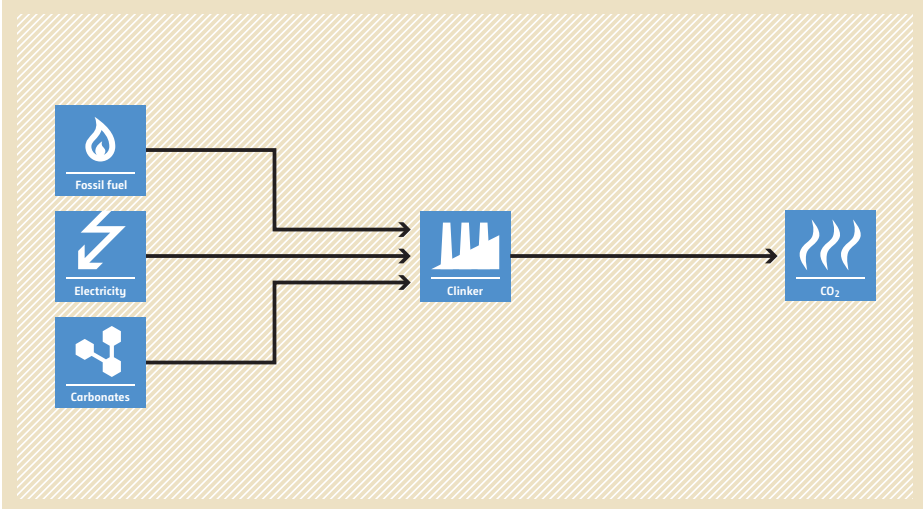
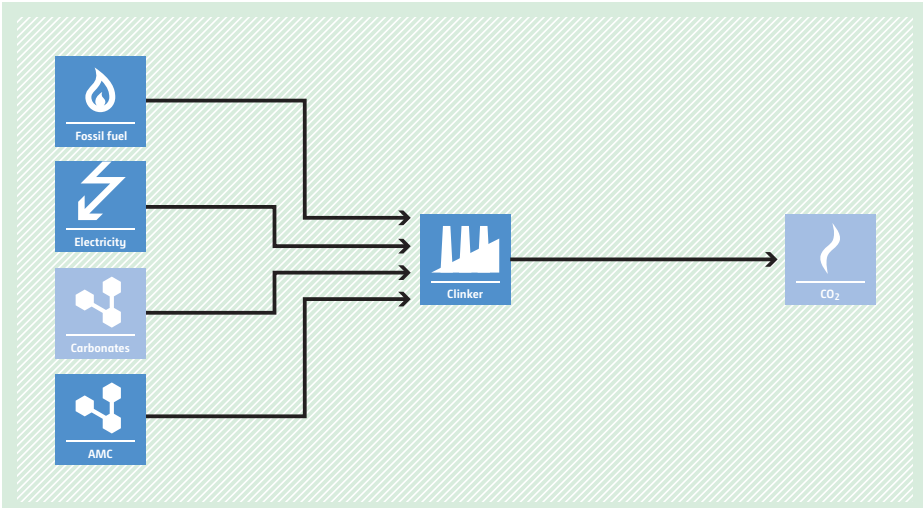
<p>Typical project(s)</p>	<p>Partial or full switch to alternative raw materials that do not contain carbonates (AMC) in the production of clinker in cement kilns in existing and Greenfield cement plants, with or without additional energy efficiency measures.</p>
<p>Type of GHG emissions mitigation action</p>	<ul style="list-style-type: none"> • Feedstock switch; • Energy efficiency. <p>Avoidance of process CO₂ emissions by switching to carbonate free feedstock in the production of clinker. Additional energy efficiency measures may be implemented.</p>
<p>Important conditions under which the methodology is applicable</p>	<ul style="list-style-type: none"> • Installed capacity of clinker production, lifetime of equipment, quality and types of clinker are not changed; • No AMC have previously been used in the clinker production at the plant; • At least 1.5 times the quantity of AMC required for meeting the aggregate demand of the proposed project activity and all existing users consuming the same AMC in the project area is available.
<p>Important parameters</p>	<p>At validation:</p> <ul style="list-style-type: none"> • Historical raw material use and clinker production and quality for existing plants. <p>Monitored:</p> <ul style="list-style-type: none"> • Quantity of alternative materials consumed in the project; • Quantity and quality of clinker produced in the project; • Specific Kiln Calorific Consumption; • Electricity consumption.
<p>BASELINE SCENARIO Raw materials that contain calcium and/or magnesium carbonates (e.g. limestone) are used to produce clinker.</p>	
<p>PROJECT SCENARIO Alternative raw materials that do not contain carbonates (AMC) are used to produce clinker.</p>	

ACM0016 Baseline methodology for mass rapid transit projects



<p>Typical project(s)</p>	<p>Establishment and operation of rail-based or bus-based mass rapid transit systems in urban or suburban regions for passenger transport by replacing a traditional urban bus-driven public transport system.</p>
<p>Type of GHG emissions mitigation action</p>	<ul style="list-style-type: none"> • Energy efficiency. <p>Displacement of more-GHG and, if gaseous fuels are used, CH₄-intensive transport modes (existing fleet of buses operating under mixed traffic conditions) by less-GHG-intensive ones (newly developed rail-based systems or segregated bus lanes).</p>
<p>Important conditions under which the methodology is applicable</p>	<ul style="list-style-type: none"> • The project either installs new railways or segregated bus lanes in order to replace existing bus routes (e.g. by scrapping buses, closing or rescheduling bus routes). For bus rapid transit systems with feeder plus trunk routes, methodology AM0031 is recommended; • The methodology is applicable for urban or suburban trips. It is not applicable for inter-urban transport; • The methodology is not applicable for operational improvements (e.g. new or larger buses) of an already existing and operating bus lane or rail-based system.
<p>Important parameters</p>	<p>At validation:</p> <ul style="list-style-type: none"> • An extensive survey with the passengers using the project is required in order to determine the baseline scenario (i.e. the distance and mode of transport that the passengers using the project would have used in the baseline). <p>Monitored:</p> <ul style="list-style-type: none"> • The number of passengers transported in the project; • Specific fuel consumption, occupancy rates and travelled distances of different transport modes as well as the speed of vehicles on affected roads.
<p>BASELINE SCENARIO Passengers are transported using a diverse transport system involving buses, trains, cars, non-motorized transport modes, etc. operating under mixed traffic conditions.</p>	<p>The diagram illustrates the baseline scenario with a yellow background. On the left, there are four icons representing transport modes: Train, Bus, Car, and Motorcycle. Arrows from each icon point towards a central box containing a CO₂ emissions icon, indicating that all these modes contribute to the baseline emissions.</p>
<p>PROJECT SCENARIO Passengers are transported using newly developed rail-based systems or segregated bus lanes that partially displace the existing bus-driven transport system operated under mixed traffic conditions.</p>	<p>The diagram illustrates the project scenario with a green background. It shows the same four transport modes (Train, Bus, Car, Motorcycle) as the baseline. A central box highlights the Train and Bus modes, indicating their partial displacement. Arrows from all modes point towards a CO₂ emissions box, showing that the project scenario results in lower overall emissions compared to the baseline.</p>

ACM0017 Production of biodiesel for use as fuel

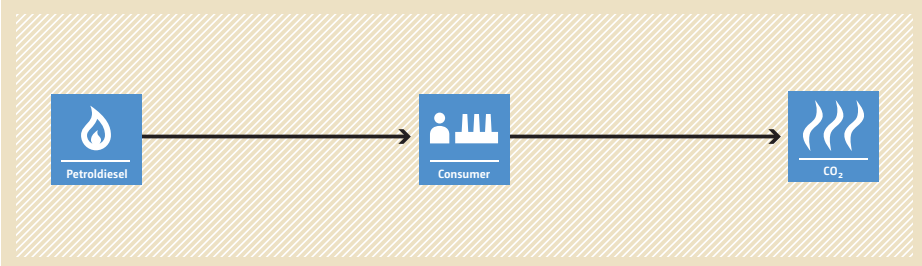
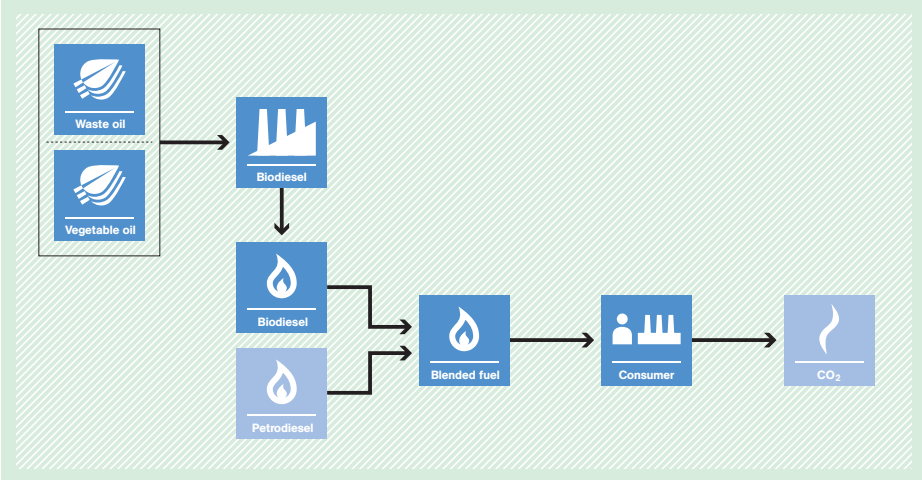
<p>Typical project(s)</p>	<p>Construction and operation of a biodiesel production plant for production of blended biodiesel that is used as fuel in existing stationary installations (e.g. diesel generators) and/or in vehicles. Biodiesel is produced from waste oil/fat and/or vegetable oil that is produced from oilseeds from plants that are cultivated on dedicated plantations established on lands that are degraded or degrading at the start of the project.</p>
<p>Type of GHG emissions mitigation action</p>	<ul style="list-style-type: none"> • Renewable energy. <p>Displacement of more-GHG-intensive fossil fuel for combustion in vehicles and/or stationary installations.</p>
<p>Important conditions under which the methodology is applicable</p>	<ul style="list-style-type: none"> • The alcohol used for esterification (production of biodiesel) is methanol from fossil fuel origin; • No modifications in the consumer stationary installations or in the vehicles engines are necessary to consume/combust the (blended) biodiesel; • If applicable, the plantations are established on land classified as degraded or degrading or on a land area that is included in the project boundary of one or several registered A/R CDM project activities; • Consumer and producer of the (blended) biodiesel are bound by a contract that allows the producer to monitor consumption of (blended) biodiesel and that states that the consumer shall not claim CERs resulting from its consumption.
<p>Important parameters</p>	<p>Monitored:</p> <ul style="list-style-type: none"> • Quantity of biodiesel from waste oil/fat or feedstock from dedicated plantations consumed by host country consumers to substitute petrodiesel; • Project emissions from transport of oilseeds, biomass residues, vegetable oil, waste oil/fats, biodiesel if distances of more than 50 km are covered; fossil fuel (including methanol) and electricity consumption; • If applicable, parameters to monitor project emissions (CO₂, CH₄, N₂O) associated with the cultivation of oilseeds.
<p>BASELINE SCENARIO Consumption of petrodiesel.</p>	 <p>The diagram shows a linear flow from left to right. It starts with a blue square icon containing a flame and the text 'Petrodiesel'. An arrow points to a blue square icon containing a factory and the text 'Consumer'. A second arrow points to a blue square icon containing three wavy lines and the text 'CO₂'.</p>
<p>PROJECT SCENARIO Production of blended biodiesel and consumption in existing stationary installations (e.g. diesel generators) and/or in vehicles.</p>	 <p>The diagram shows a multi-step process. On the left, two blue square icons (one with a leaf and 'Waste oil', one with a leaf and 'Vegetable oil') are grouped in a dashed box. An arrow points to a blue square icon with a factory and 'Biodiesel'. From there, an arrow points down to a blue square icon with a flame and 'Biodiesel'. Below this, another blue square icon with a flame and 'Petrodiesel' has an arrow pointing to a blue square icon with a flame and 'Blended fuel'. Both the 'Biodiesel' and 'Petrodiesel' icons have arrows pointing to the 'Blended fuel' icon. An arrow then points from 'Blended fuel' to a blue square icon with a factory and 'Consumer'. Finally, an arrow points from 'Consumer' to a blue square icon with three wavy lines and 'CO₂'.</p>

ACM0018 Electricity generation from biomass residues in power-only plants

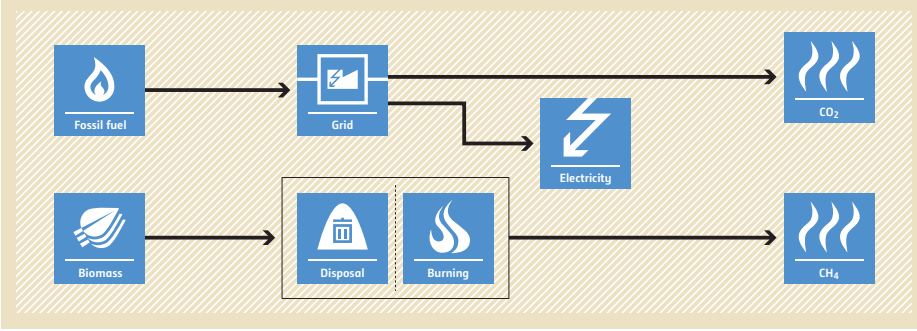
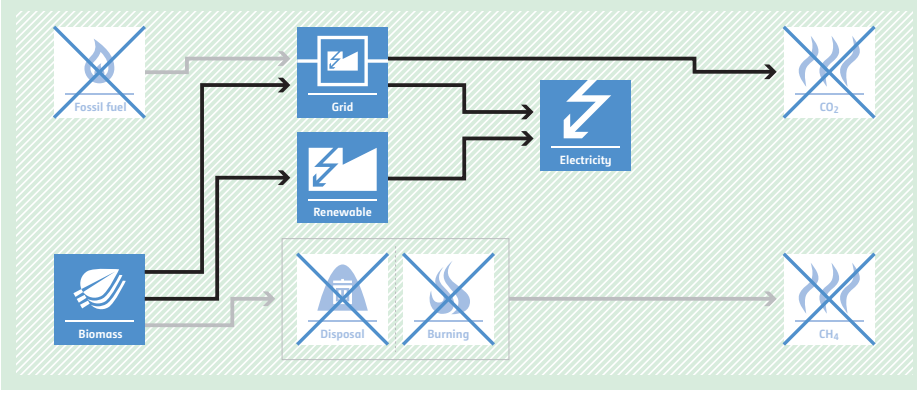
<p>Typical project(s)</p>	<p>Generation of power using biomass residues as fuel, in new biomass based power plants at sites where currently no power generation occurs (greenfield), replacement or installation of operation units next to existing power plants (capacity expansion projects), energy efficiency improvement projects or replacement of fossil fuel by biomass residues in existing power plants (fuel switch projects). The biomass based power generation may be combined with solar thermal power generation.</p>
<p>Type of GHG emissions mitigation action</p>	<ul style="list-style-type: none"> • Renewable energy; • Energy efficiency; • Fuel switch. • Displacement of more GHG-intensive electricity generation in the grid or on-site. • Avoidance of methane emissions from anaerobic decay of biomass residues.
<p>Important conditions under which the methodology is applicable</p>	<ul style="list-style-type: none"> • If biomass from a production process is used, the implementation of the project shall not result in an increase of the processing capacity of raw input; • The methodology is applicable to power-only plants; • Only biomass residues, not biomass in general, are eligible; • Fossil fuels may be co-fired in the project plant. However, the amount of fossil fuels co-fired shall not exceed 80% of the total fuel fired on an energy basis; • In case of existing facilities, three years of historical data is required for the calculation of emissions reductions; • Projects that chemically process the biomass residues prior to combustion (e.g. by means of esterification of waste oils, fermentation and gasification, etc.) are not eligible under this methodology. The biomass residues can however be processed physically such as by means of drying, pelletization, shredding and briquetting.
<p>Important parameters</p>	<p>At validation:</p> <ul style="list-style-type: none"> • If applicable: grid emission factor (can also be monitored ex post). <p>Monitored:</p> <ul style="list-style-type: none"> • Electricity generated in the project; • Quantity and moisture content of the biomass residues used in the project and electricity and fossil fuel consumption of the project.
<p>BASELINE SCENARIO Electricity would be produced by more-carbon-intensive technologies based on fossil fuel or less efficient power plants. Biomass residues could partially decay under anaerobic conditions, resulting in methane emissions.</p>	 <p>The baseline scenario flowchart shows two main paths. The top path starts with 'Fossil fuel' (flame icon) leading to 'Grid' (power plug icon), which then leads to 'Electricity' (lightning bolt icon) and finally to 'CO2' (flame icon). The bottom path starts with 'Biomass' (leaf icon) leading to a box containing 'Disposal' (trash can icon) and 'Burning' (flame icon). From this box, arrows point to 'Electricity' and 'CH4' (flame icon).</p>
<p>PROJECT SCENARIO Use of biomass residues replaces fossil fuel use. Decay of biomass residues used as fuel is avoided.</p>	 <p>The project scenario flowchart shows a similar structure to the baseline but with key changes. 'Fossil fuel' and 'Biomass' both lead to 'Grid' and 'Renewable' (power plug icon). 'Grid' leads to 'Electricity', which then leads to 'CO2'. 'Renewable' also leads to 'Electricity'. 'Biomass' leads to a box containing 'Disposal' and 'Burning'. From this box, arrows point to 'Electricity' and 'CH4'. In this scenario, the 'Fossil fuel', 'Disposal', 'Burning', and 'CO2' icons are crossed out with a large 'X', indicating they are avoided or replaced.</p>

ACM0019 N₂O abatement from nitric acid production

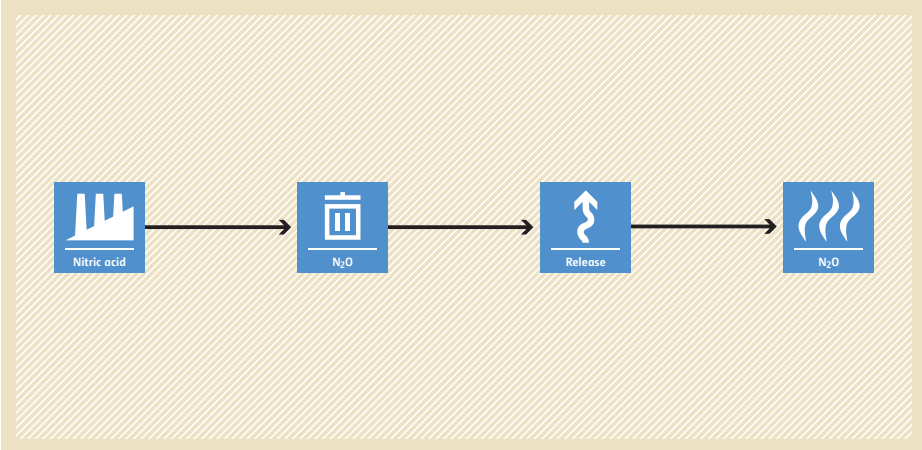
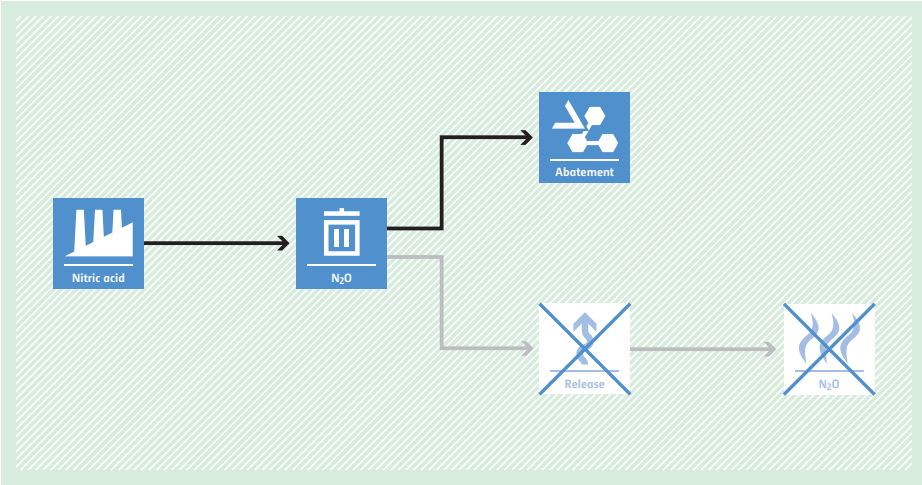
Typical project(s)	Project activities that introduce N ₂ O abatement measures in nitric acid plants.
Type of GHG emissions mitigation action	<ul style="list-style-type: none"> • Destruction of GHG. Destruction of N ₂ O emissions through abatement measures.
Important conditions under which the methodology is applicable	<ul style="list-style-type: none"> • Continuous real-time measurements of the N₂O concentration and the total gas volume flow can be carried out in the tail gas stream after the abatement of N₂O emissions throughout the crediting period of the project activity; • No law or regulation is in place mandating the complete or partial destruction of N₂O from nitric acid plant.
Important parameters	At validation: <ul style="list-style-type: none"> • Nitric acid produced. <hr/> Monitored: <ul style="list-style-type: none"> • Mass flow of N₂O in the gaseous stream of the tail gas; • Nitric acid produced; • Fraction of time during which the by-pass valve on the line feeding the tertiary N₂O abatement facility was open.
BASELINE SCENARIO Venting of N ₂ O generated during the production of nitric acid to the atmosphere.	 <p>The diagram illustrates the baseline scenario. It starts with a 'Nitric acid' icon (factory) on the left. An arrow points to an 'N₂O' icon (gas cylinder). A second arrow points to a 'Release' icon (upward arrow). A final arrow points to an 'N₂O' icon (flames), representing emissions to the atmosphere.</p>
PROJECT SCENARIO Implementation of different abatement measures to destroy N ₂ O emissions (i.e. installation of secondary or tertiary abatement systems).	 <p>The diagram illustrates the project scenario. It starts with a 'Nitric acid' icon (factory) on the left. An arrow points to an 'N₂O' icon (gas cylinder). From this point, the path splits: one arrow goes up to an 'Abatement' icon (circular arrows), and another arrow goes down to a 'Release' icon (upward arrow) that has a large blue 'X' over it. A final arrow points from the 'Release' icon to an 'N₂O' icon (flames) that also has a large blue 'X' over it, indicating that emissions are prevented.</p>

ACM0020 Co-firing of biomass residues for heat generation and/or electricity generation in grid connected power plants

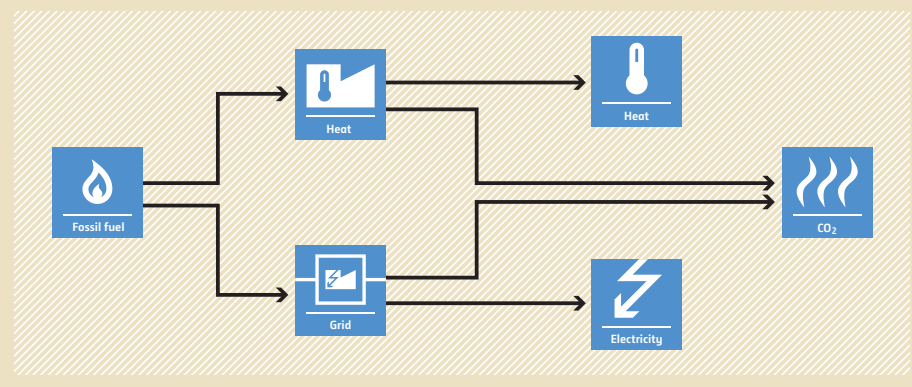
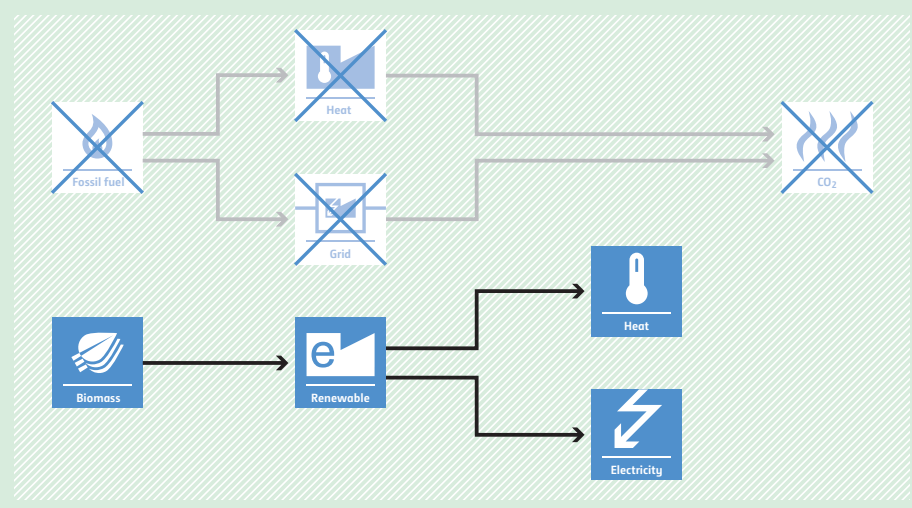
<p>Typical project(s)</p>	<p>Operation of a single piece of biomass-residue co-fired heat generation equipment. The heat output of the heat generators may be used onsite to produce electric power in power-only plants, or cogenerate electric power in cogeneration plants. Typical activities are partial replacement of fossil fuels by biomass residues in existing or new heat generation equipment.</p>
<p>Type of GHG emissions mitigation action</p>	<ul style="list-style-type: none"> • Renewable Energy. <p>Displacement of more-GHG-intensive electricity generation in grid or heat and electricity generation on-site.</p>
<p>Important conditions under which the methodology is applicable</p>	<ul style="list-style-type: none"> • If biomass from a production process is used, the implementation of the project shall not result in an increase of the processing capacity of raw input; • Only biomass residues, not biomass in general, are eligible; • The amount of biomass residues co-fired shall not exceed 50% of the total fuel fired on an energy basis; • No biomass is co-fired in the identified baseline scenario and the same type of fossil fuel is fired in the identified baseline scenario as in the project activity.
<p>Important parameters</p>	<p>At validation:</p> <ul style="list-style-type: none"> • If applicable: grid emission factor (can also be monitored ex post). <p>Monitored:</p> <ul style="list-style-type: none"> • Quantity and moisture content of the biomass residues used in the project; • Electricity and/or heat generated in the project activity; • Electricity and fossil fuel consumption of the project activity.
<p>BASELINE SCENARIO Electricity or heat would be produced by more-carbon-intensive technologies based on fossil fuel</p>	 <p>The diagram illustrates the baseline scenario. It starts with 'Fossil fuel' (represented by a flame icon) which is processed into 'Heat' (thermometer icon) and 'Grid' (power plug icon). The 'Heat' path leads to 'Heat' (thermometer icon) and 'CO2' (flame icon). The 'Grid' path leads to 'Electricity' (lightning bolt icon) and 'CO2' (flame icon).</p>
<p>PROJECT SCENARIO Use of biomass residues for power or heat generation instead of fossil fuel.</p>	 <p>The diagram illustrates the project scenario. It shows 'Biomass' (leaf icon) being converted into 'Renewable' energy (e icon). This 'Renewable' energy is then used to produce 'Heat' (thermometer icon) and 'Electricity' (lightning bolt icon). The 'Heat' path leads to 'Heat' (thermometer icon) and 'CO2' (flame icon). The 'Electricity' path leads to 'Electricity' (lightning bolt icon) and 'CO2' (flame icon). The 'Fossil fuel' and 'Grid' paths from the baseline scenario are shown as crossed-out icons, indicating they are replaced by biomass.</p>

ACM0021 Reduction of emissions from charcoal production by improved kiln design and/or abatement of methane

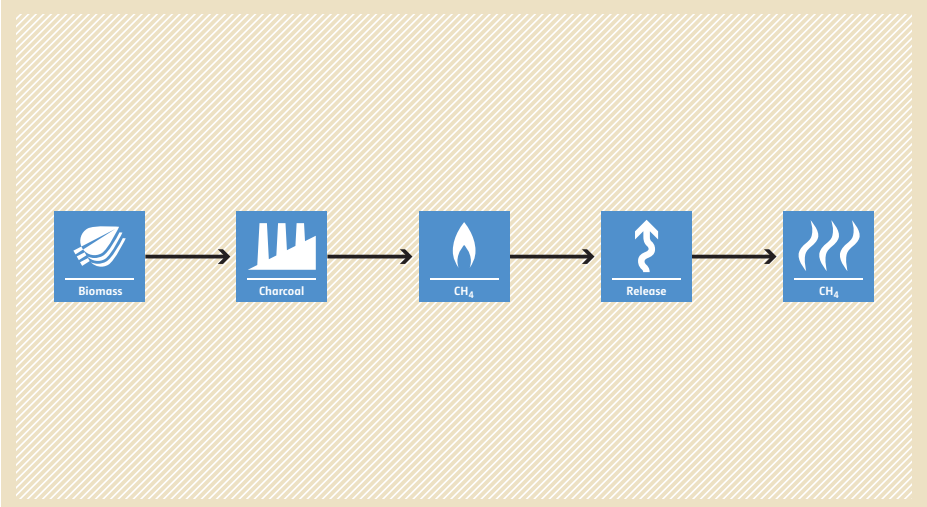
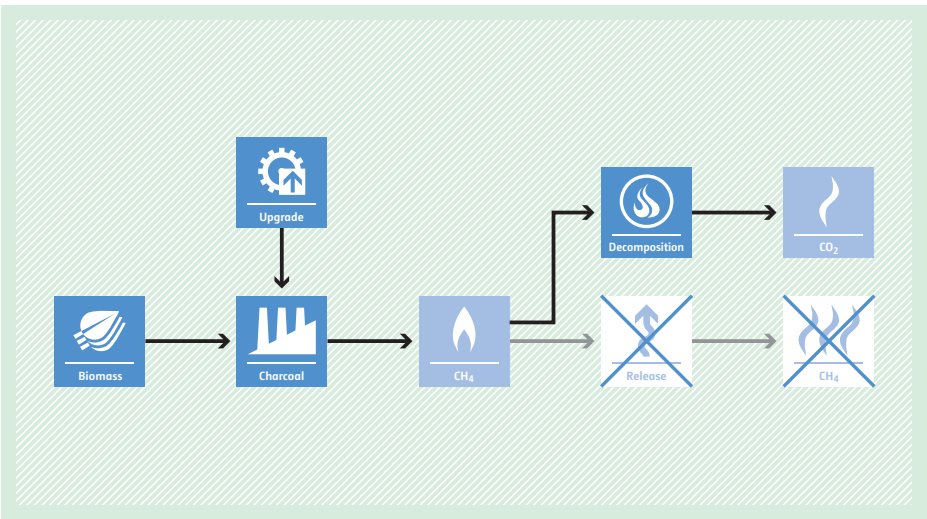
<p>Typical project(s)</p>	<p>Installation of charcoal kilns of enhanced design to replace existing kilns, and/or installation of methane abatement units at existing or new kilns.</p>
<p>Type of GHG emissions mitigation action</p>	<ul style="list-style-type: none"> • GHG emission avoidance. <p>Avoidance or reduction of CH₄ emissions in charcoal production process.</p>
<p>Important conditions under which the methodology is applicable</p>	<ul style="list-style-type: none"> • The project does not change the type and sources of input for charcoal production; • There are no regulations that prevent venting of methane generated from charcoal production facility; • All the existing kilns affected by the project activity shall have the same mechanical design.
<p>Important parameters</p>	<p>Monitored:</p> <ul style="list-style-type: none"> • Charcoal production of each kiln; • Start time and end time of each carbonization cycle of each kiln; • Combustion status of each methane abatement unit (if applicable).
<p>BASELINE SCENARIO High CH₄ emissions associated with the production of charcoal.</p>	 <p>The baseline scenario flowchart illustrates the process of charcoal production and methane emissions. It starts with 'Biomass' (represented by a leaf icon), which is processed into 'Charcoal' (represented by a factory icon). The charcoal is then used to produce 'CH₄' (represented by a flame icon). This CH₄ is then 'Released' (represented by an upward arrow icon) into the atmosphere, where it is shown as 'CH₄' (represented by a flame icon).</p>
<p>PROJECT SCENARIO Decreased or avoided CH₄ emissions associated with production of charcoal.</p>	 <p>The project scenario flowchart illustrates the process of charcoal production with methane abatement. It starts with 'Biomass' (represented by a leaf icon), which is processed into 'Charcoal' (represented by a factory icon). An 'Upgrade' (represented by a gear icon) is applied to the charcoal production process. The charcoal is then used to produce 'CH₄' (represented by a flame icon). This CH₄ is then captured and sent to a 'Decomposition' unit (represented by a flame icon with a downward arrow), which produces 'CO₂' (represented by a flame icon). The 'Release' unit (represented by an upward arrow icon) is crossed out with a large 'X', indicating that methane release is avoided. The 'CH₄' (represented by a flame icon) is also crossed out with a large 'X', indicating that methane emissions are avoided.</p>

ACM0022 Alternative waste treatment processes



<p>Typical project(s)</p>	<p>The project involves one or a combination of the following waste treatment options: Composting process in aerobic conditions; Gasification to produce syngas and its use; Anaerobic digestion with biogas collection and flaring and/or its use (this includes processing and upgrading biogas and then distribution of it via a natural gas distribution grid); Mechanical/thermal treatment process to produce refuse-derived fuel (RDF)/stabilized biomass (SB) and its use; Incineration of fresh waste for energy generation, electricity and/or heat; Treatment of wastewater in combination with solid waste, by co-composting or in an anaerobic digester.</p>
<p>Type of GHG emissions mitigation action</p>	<ul style="list-style-type: none"> • GHG emission avoidance; • Renewable energy. <p>CH₄ emissions due to anaerobic decay of organic waste are avoided by alternative waste treatment processes. Organic waste is used as renewable energy source.</p>
<p>Important conditions under which the methodology is applicable</p>	<ul style="list-style-type: none"> • The proportions and characteristics of different types of organic waste processed in the project can be determined; • Neither hospital nor industrial waste may be treated through anaerobic digestion, thermal treatment or mechanical treatment; • The project activity does not reduce the amount of waste that would be recycled in the absence of the project; • The baseline scenario is the disposal of the waste in a landfill site without capturing landfill gas or with partly capturing it and subsequently flaring it.
<p>Important parameters</p>	<p>Monitored:</p> <ul style="list-style-type: none"> • Weight fraction of the different waste types in a sample and total amount of organic waste prevented from disposal; • Electricity and fossil fuel consumption in the project site.
<p>BASELINE SCENARIO Disposal of the waste in a landfill site without capturing landfill gas or with partly capturing and subsequently flaring it.</p>	<pre> graph LR Waste[Waste] --> Disposal[Disposal] Disposal --> LandfillGas[Landfill gas] LandfillGas --> Release[Release] Release --> CH4[CH4] </pre>
<p>PROJECT SCENARIO Alternative waste treatment process. Such processes could be composting, gasification, anaerobic digestion with biogas collection and flaring and/or its use, mechanical/thermal treatment process to produce RDF or SB and its use, or incineration of fresh waste for energy generation.</p>	<pre> graph LR Waste[Waste] --> Composting[Composting] Waste --> Treatment[Treatment] Treatment --> Burning[Burning] Waste -.-> Disposal[Disposal] Disposal -.-> LandfillGas[Landfill gas] LandfillGas -.-> Release[Release] Release -.-> CH4[CH4] Disposal -.-> CH4 </pre>

ACM0023 Introduction of an efficiency improvement technology in a boiler

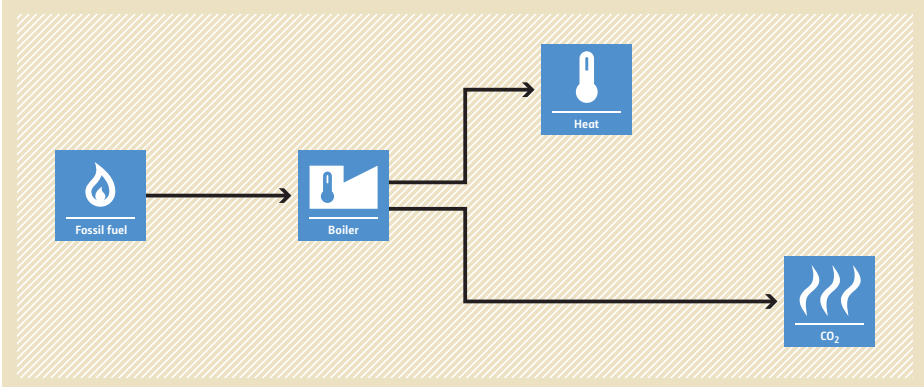
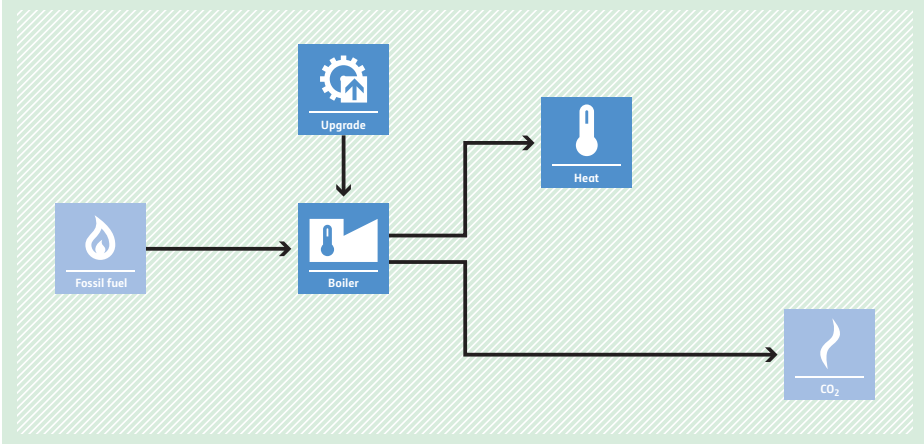
<p>Typical project(s)</p>	<p>Improvement of the boiler efficiency through introduction of efficiency improvement technology.</p>
<p>Type of GHG emissions mitigation action</p>	<ul style="list-style-type: none"> • Energy efficiency. <p>Switch to more-energy-efficient technology.</p>
<p>Important conditions under which the methodology is applicable</p>	<ul style="list-style-type: none"> • The boiler has an operating history of at least three years; • The efficiency improvement technology to be used under the project activity was not used at the project facility on a commercial basis prior to the implementation of the project activity; • The type of fossil fuel used by the project during the crediting period was also used during the most recent three years prior to the implementation of the project activity; • The technologies allowed are oil/water emulsion technology, fire side cleaning technology and coal catalyst technology.
<p>Important parameters</p>	<p>At validation:</p> <ul style="list-style-type: none"> • Historical fuel consumption in boiler. <p>Monitored:</p> <ul style="list-style-type: none"> • Fuel consumption in the boiler; • Energy generation from the boiler.
<p>BASELINE SCENARIO Operation of boilers at lower efficiency of combustion in absence of efficiency improvement technology.</p>	 <p>The diagram shows a flow from 'Fossil fuel' (flame icon) to a 'Boiler' (thermometer icon). From the boiler, two arrows branch out: one to 'Heat' (thermometer icon) and one to 'CO2' (flame icon).</p>
<p>PROJECT SCENARIO Efficiency improvement technology is introduced to improve the efficiency of boilers.</p>	 <p>The diagram is similar to the baseline scenario but includes an 'Upgrade' (gear icon) box with an arrow pointing to the 'Boiler' box, indicating the introduction of efficiency improvement technology.</p>

ACM0024 Natural gas substitution by biogenic methane produced from the anaerobic digestion of organic waste

<p>Typical project(s)</p>	<p>Project activities where organic waste (e.g. vinasse, organic MSW, etc.) is treated by anaerobic digestion. The resulted output is upgraded and used to replace natural gas in a natural gas distribution system.</p>
<p>Type of GHG emissions mitigation action</p>	<ul style="list-style-type: none"> • Renewable Energy. <p>Organic waste is used as renewable energy source by the displacement of natural gas in a natural gas distribution system.</p>
<p>Important conditions under which the methodology is applicable</p>	<ul style="list-style-type: none"> • The project does not reduce the amount of waste that would be recycled in the absence of the project activity; • Resulting digestate is further stabilized aerobically (e.g. composted), applied to land or sent to a solid waste disposal site; • Neither organic waste nor products and by-products from the anaerobic digester established under the project activity are stored on-site under anaerobic conditions.
<p>Important parameters</p>	<p>Monitored:</p> <ul style="list-style-type: none"> • Amount of methane produced in the anaerobic digester before upgrading; • Amount of biogenic methane which is sent to the natural gas distribution system after upgrading.
<p>BASELINE SCENARIO Supply of natural gas to a natural gas distribution system.</p>	<p>The baseline scenario flowchart shows a linear process: Natural gas (represented by a flame icon) is supplied to a Natural gas distribution system (represented by a flame icon inside a square), which then supplies it to a Consumer (represented by a factory icon), resulting in CO2 emissions (represented by a flame icon).</p>
<p>PROJECT SCENARIO Organic waste is treated by anaerobic digestion. The resulted output is upgraded and used to replace natural gas in a natural gas distribution system.</p>	<p>The project scenario flowchart illustrates the process from waste to biogenic methane. It starts with Waste (trash icon) going to Treatment (factory icon), producing Biogas (flame icon). Biogas is then processed (factory icon) into CH4 (flame icon). This CH4 is used to produce Natural gas (flame icon), which is then supplied to a Consumer (factory icon). The flowchart also shows a crossed-out Natural gas icon and a crossed-out CO2 icon, indicating that natural gas is displaced and CO2 emissions are reduced compared to the baseline.</p>



CDM Methodology Booklet

Chapter III

3.4. METHODOLOGIES FOR SMALL-SCALE CDM PROJECT ACTIVITIES

AMS-I.A. Electricity generation by the user

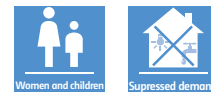

<p>Typical project(s)</p>	<p>Renewable electricity generation such as solar, hydro, wind or biomass gasification are implemented by the users as new installations (greenfield) or replacement of existing onsite fossil-fuel-fired generation.</p>
<p>Type of GHG emissions mitigation action</p>	<ul style="list-style-type: none"> • Renewable energy. • Displacement of more-GHG-intensive service (e.g. refrigeration or lighting).
<p>Important conditions under which the methodology is applicable</p>	<ul style="list-style-type: none"> • Users are in off-grid locations, i.e. they do not have connection to a national/regional grid, unless exceptional situations, e.g. weak grids; • Users are included in the project boundary; • Conditions apply for reservoir-based hydro plants.
<p>Important parameters</p>	<p>At validation:</p> <ul style="list-style-type: none"> • Trend-adjusted projection of historical fuel consumption if an existing technology is replaced (for lighting, daily use duration can be applied). <p>Monitored:</p> <ul style="list-style-type: none"> • An annual check of all systems or a sample thereof to ensure that they are still operating, or metering of generated electricity; • If applicable, consumption of energy sources (e.g. biomass, fossil fuel); • If applicable, availability of connected grid.
<p>BASELINE SCENARIO Services (e.g. lighting and refrigeration) are provided using fossil-fuel-based technologies (e.g. kerosene lamps and diesel generators).</p>	<pre> graph LR FF[Fossil fuel] --> PP[Power plant] PP --> E[Electricity] PP --> CO2[CO2] E --> C[Consumer] </pre>
<p>PROJECT SCENARIO Electricity is produced by users using renewable energy technologies (e.g. solar home systems for lighting, wind battery chargers for powering domestic appliances).</p>	<pre> graph LR FF[Fossil fuel] --> PP[Power plant] PP --> E[Electricity] PP --> CO2[CO2] E --> C[Consumer] style FF stroke-dasharray: 5 5 style PP stroke-dasharray: 5 5 style CO2 stroke-dasharray: 5 5 </pre>

AMS-I.B. Mechanical energy for the user with or without electrical energy



<p>Typical project(s)</p>	<p>Installation of renewable energy technologies such as hydropower, wind power and other technologies that provide mechanical energy that otherwise would have been supplied with fossil-fuel-based energy. Mechanical energy is used on-site by individual household(s) or user(s). Typical applications are wind-powered pumps, water mills and wind mills. The project may also produce electricity in addition to mechanical energy.</p>
<p>Type of GHG emissions mitigation action</p>	<ul style="list-style-type: none"> • Renewable energy. • Displacement of more-GHG-intensive fossil-fuel-based generation of mechanical power.
<p>Important conditions under which the methodology is applicable</p>	<ul style="list-style-type: none"> • Operating characteristics of the project system (e.g. head vs. discharge and efficiency of irrigation pump) should be similar to or better than the system being replaced or that would have been replaced.
<p>Important parameters</p>	<p>Monitored:</p> <ul style="list-style-type: none"> • An annual check of all systems or a sample thereof to ensure that they are still operating; • Annual hours of operation can be estimated from total output (e.g. tonnes of grain milled); • If applicable: quantity of each type of energy sources consumed (e.g. biomass, fossil fuel). Net calorific value and moisture content of biomass.
<p>BASELINE SCENARIO Mechanical energy would be produced using fossil-fuel-based technologies.</p>	<pre> graph LR FF[Fossil fuel] --> E[Energy] E --> ME[Mechanical] E --> CO2[CO2] ME --> C[Consumer] </pre>
<p>PROJECT SCENARIO Mechanical energy is produced (with or without electricity) using renewable energy technologies.</p>	<pre> graph LR FFdel[Fossil fuel] --> Edel[Energy] RE[Renewable] --> Edel Edel --> ME[Mechanical] Edel --> CO2del[CO2] ME --> C[Consumer] </pre>

AMS-I.C. Thermal energy production with or without electricity



Typical project(s)	Thermal energy production using renewable energy sources including biomass-based cogeneration and/or trigeneration. Projects that seek to retrofit or modify existing facilities for renewable energy generation are also applicable.
Type of GHG emissions mitigation action	<ul style="list-style-type: none"> Renewable energy. Displacement of more-GHG-intensive thermal energy production, displacement of more-GHG-intensive thermal energy and/or electricity generation.
Important conditions under which the methodology is applicable	<ul style="list-style-type: none"> Thermal energy and/or electricity production using biomass-based cogeneration and trigeneration system is eligible; If solid biomass is used, it has to be demonstrated that solely renewable biomass is used. If charcoal or biomass fuel is used, all project or leakage emissions (e.g. release of methane) from the fuel production have to be considered; If project equipment contains refrigerants, then the refrigerant used in the project case shall have no ozone depleting potential (ODP).
Important parameters	Monitored: <ul style="list-style-type: none"> The moisture content of biomass of homogeneous quality may be fixed ex ante or monitored for each batch of biomass if the emission reductions are calculated based on energy input; Thermal energy (mass flow, temperature, pressure for heat/cooling) delivered by the project and the amount of grid and/or captive electricity displaced; Quantity of biomass and fossil fuel consumed; Net calorific value of biomass shall be determined once in the first year of the crediting period; The chilled water mass flow-rate for chiller(s); Cooling output of baseline chiller displaced as a result of the installation of project activity; Quantity of refrigerant used to replace refrigerant that has leaked.

BASELINE SCENARIO
Energy generation (thermal heat and / or electricity) by more-carbon-intensive technologies based on fossil fuel. In case of retrofits or capacity addition, operation of existing renewable power units without retrofit and capacity addition.

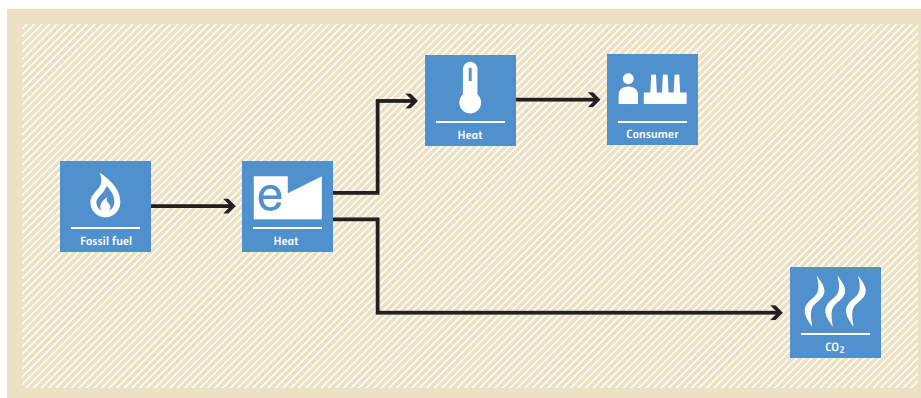

PROJECT SCENARIO
Energy generation by installation of new renewable energy generation units, by retrofitting or replacement of existing renewable energy generation units as well as by switch from fossil fuel to biomass in modified existing facilities.

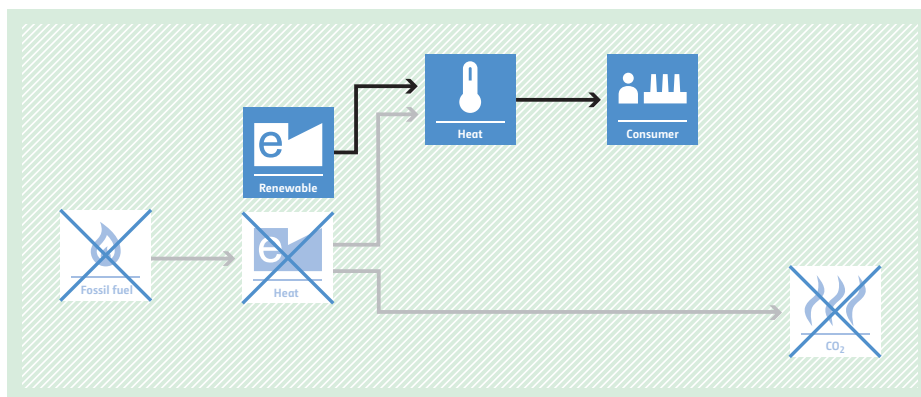



AMS-I.D. Grid connected renewable electricity generation

<p>Typical project(s)</p>	<p>Construction and operation of a power plant that uses renewable energy sources and supplies electricity to the grid (greenfield power plant) or retrofit, replacement or capacity addition of an existing power plant that uses renewable energy sources and supplies electricity to the grid.</p>
<p>Type of GHG emissions mitigation action</p>	<ul style="list-style-type: none"> • Renewable energy. <p>Displacement of electricity that would be provided to the grid by more-GHG-intensive means.</p>
<p>Important conditions under which the methodology is applicable</p>	<ul style="list-style-type: none"> • Combined heat and power generation is not eligible (AMS-I.C. can be used here); • Special conditions apply for reservoir-based hydro plants.
<p>Important parameters</p>	<p>At validation:</p> <ul style="list-style-type: none"> • Grid emission factor (can also be monitored ex post); • Moisture content of biomass of homogeneous quality shall be determined ex ante. <p>Monitored:</p> <ul style="list-style-type: none"> • Quantity of net electricity supplied to the grid; • Quantity of biomass/fossil fuel consumed; • Net calorific value of biomass shall be determined once in the first year of the crediting period.
<p>BASELINE SCENARIO Electricity provided to the grid by more-GHG-intensive means.</p>	<p>The diagram illustrates the baseline scenario. It starts with a 'Fossil Fuel' icon (flame) on the left. An arrow points to a 'Grid' icon (power lines). From this 'Grid' icon, two arrows branch out: one points to an 'Electricity' icon (lightning bolt) and another points to a 'CO₂' icon (flames). The 'Electricity' icon then points to a second 'Grid' icon, which represents the distribution network.</p>
<p>PROJECT SCENARIO Electricity is generated and supplied to the grid using renewable energy technologies.</p>	<p>The diagram illustrates the project scenario. It starts with a 'Renewable' icon (solar panel) on the left. An arrow points to a 'Grid' icon (power lines). From this 'Grid' icon, two arrows branch out: one points to an 'Electricity' icon (lightning bolt) and another points to a 'CO₂' icon (flames). The 'Electricity' icon then points to a second 'Grid' icon, which represents the distribution network. The 'Fossil fuel' and 'CO₂' icons from the baseline scenario are crossed out with a large 'X' to indicate they are no longer part of the project scenario.</p>

AMS-I.E. Switch from non-renewable biomass for thermal applications by the user



<p>Typical project(s)</p>	<p>Generation of thermal energy by introducing renewable energy technologies for end-users that displace the use of non-renewable biomass. Examples of these technologies include, but are not limited to, biogas stoves, solar cookers or passive solar homes and safe drinking water applications.</p>
<p>Type of GHG emissions mitigation action</p>	<ul style="list-style-type: none"> • Renewable energy. <p>Displacement of more-GHG-intensive, non-renewable biomass-fuelled applications by introducing renewable energy technologies.</p>
<p>Important conditions under which the methodology is applicable</p>	<ul style="list-style-type: none"> • It shall be demonstrated that non-renewable biomass has been used since 31 December 1989; • Project appliances are continuously operated or replaced by equivalent service appliances; • Project participants shall determine the share of renewable and non-renewable woody biomass in the quantity of woody biomass used in the absence of the project activity.
<p>Important parameters</p>	<p>Monitored:</p> <ul style="list-style-type: none"> • Biennial check of efficiency of the project appliances (e.g. by representative sample) and monitoring of the quantity of renewable biomass used by the project; • Leakage: the amount of woody biomass saved under the project that is used by non-project households/users (who previously used renewable energy sources) shall be assessed from surveys; • If applicable: volume of drinking water per person and day using survey methods and compliance of the water quality with relevant national or international (WHO, US-EPA) microbiological water quality guidelines/standards.
<p>BASELINE SCENARIO Thermal energy would be produced by more-GHG-intensive means based on the use of non-renewable biomass.</p>	<pre> graph LR NR[Non-renewable] --> H1[Heat] H1 --> H2[Heat] H2 --> C[Consumer] H1 --> CO2[CO2] </pre>
<p>PROJECT SCENARIO Use of renewable energy technologies for thermal energy generation, displacing non-renewable biomass use.</p>	<pre> graph LR R1[Renewable] --> H1[Heat] R2[Renewable] --> H2[Heat] H1 --> H3[Heat] H2 --> H3 H3 --> C[Consumer] NR[Non-renewable] --> CO2[CO2] CO2 --> CO2_Crossed[CO2] </pre>

AMS-I.F. Renewable electricity generation for captive use and mini-grid



<p>Typical project(s)</p>	<p>Production of electricity using renewable energy technologies such as photovoltaic, hydro, tidal/wave, wind, geothermal and renewable biomass that supply electricity to user(s).</p>
<p>Type of GHG emissions mitigation action</p>	<ul style="list-style-type: none"> • Renewable energy. <p>Displacement of electricity that would be provided to the user(s) by more-GHG-intensive means.</p>
<p>Important conditions under which the methodology is applicable</p>	<ul style="list-style-type: none"> • The project will displace electricity from an electricity distribution system that is or would have been supplied by at least one fossil fuel fired generating unit; • Electricity is produced by installing a new power plant (greenfield) or by capacity addition/retrofit/replacement of (an) existing plant(s); • Special conditions apply for reservoir-based hydro plants; • Cogeneration projects are not eligible.
<p>Important parameters</p>	<p>At validation:</p> <ul style="list-style-type: none"> • If applicable: grid emission factor (can also be monitored ex post). <p>Monitored:</p> <ul style="list-style-type: none"> • Net electricity generation, quantity of fossil fuel and biomass consumption.
<p>BASILINE SCENARIO Electricity would have been supplied by one or more energy sources such as a national or a regional grid or a fossil-fuel-fired captive power plant or a carbon-intensive mini-grid.</p>	<p>The diagram illustrates the baseline scenario. On the left, a 'Fossil fuel' icon (flame) has an arrow pointing to a box containing 'Grid' and 'Power plant' icons. From this box, two arrows branch out: one to an 'Electricity' icon (lightning bolt) which then points to a 'Consumer' icon (factory), and another to a 'CO2' icon (flames). The entire process is set against a light brown background.</p>
<p>PROJECT SCENARIO Electricity is supplied using renewable energy technologies.</p>	<p>The diagram illustrates the project scenario. On the left, a 'Fossil fuel' icon (flame) is crossed out with a blue 'X'. An arrow points to a box containing 'Renewable' (lightning bolt), 'Grid' (crossed out), and 'Power plant' (crossed out) icons. From this box, two arrows branch out: one to an 'Electricity' icon (lightning bolt) which then points to a 'Consumer' icon (factory), and another to a 'CO2' icon (flames) which is also crossed out with a blue 'X'. The entire process is set against a light green background.</p>

AMS-I.G. Plant oil production and use for energy generation in stationary applications



<p>Typical project(s)</p>	<p>Plant oil production that is used for generation of thermal, mechanical and electrical energy in stationary equipment including cogeneration. The plant oil is produced from pressed and filtered oilseeds from plants that are cultivated on dedicated plantations.</p>
<p>Type of GHG emissions mitigation action</p>	<ul style="list-style-type: none"> • Renewable energy. • Displacement of more-GHG-intensive fossil fuel for combustion in stationary installations.
<p>Important conditions under which the methodology is applicable</p>	<ul style="list-style-type: none"> • The pure plant oil and its blends above 10% is used in specially built or modified equipment; • Export of produced plant oil is not allowed; • Oil crops are cultivated on area which is not a forest and has not been deforested during the last 10 years prior to the implementation of the project. Plantations established on peatlands are not eligible.
<p>Important parameters</p>	<p>Monitored:</p> <ul style="list-style-type: none"> • Energy consumption of the combustion processes (e.g. plant oil, fossil fuel); • Parameters to estimate project emissions from the cultivation of oil crops if the default values for jatropha and palm oil are not applied; • If applicable: leakage emissions due to a shift of pre-project activities and the competing uses of biomass; • Quantity of the electricity produced; of the thermal energy (mass flow, temperature, pressure for heat/cooling) generated by the project; • Project emissions from fossil fuel and electricity consumption as well as from the transport of oilseeds if distances of more than 200 km are covered.
<p>BASELINE SCENARIO Services (e.g. electricity, thermal and mechanical energy supply) are provided using fossil-fuel-based technologies.</p>	<p>The diagram shows a flow from 'Fossil fuel' (flame icon) to 'Energy' (e icon). From 'Energy', three arrows point to 'Electricity' (lightning bolt icon), 'Heat' (thermometer icon), and 'Mechanical' (gears icon). A separate arrow from 'Energy' points to 'CO₂' (flame icon with wavy lines).</p>
<p>PROJECT SCENARIO Oil crops are cultivated, plant oil is produced and used for the generation of electricity, thermal or mechanical energy displacing fossil fuel.</p>	<p>The diagram shows 'Plantation' (crops icon) leading to 'Plant oil' (oil drop icon). 'Plant oil' leads to 'Energy' (e icon). 'Fossil fuel' (flame icon) is crossed out with a blue 'X' and has a grey arrow pointing to 'Energy'. From 'Energy', three arrows point to 'Electricity' (lightning bolt icon), 'Heat' (thermometer icon), and 'Mechanical' (gears icon). A separate arrow from 'Energy' points to 'CO₂' (flame icon with wavy lines), which is also crossed out with a blue 'X'.</p>

AMS-I.H. Biodiesel production and use for energy generation in stationary applications

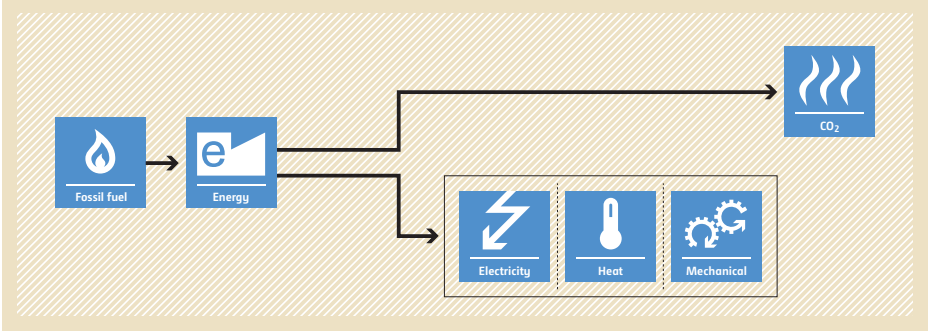
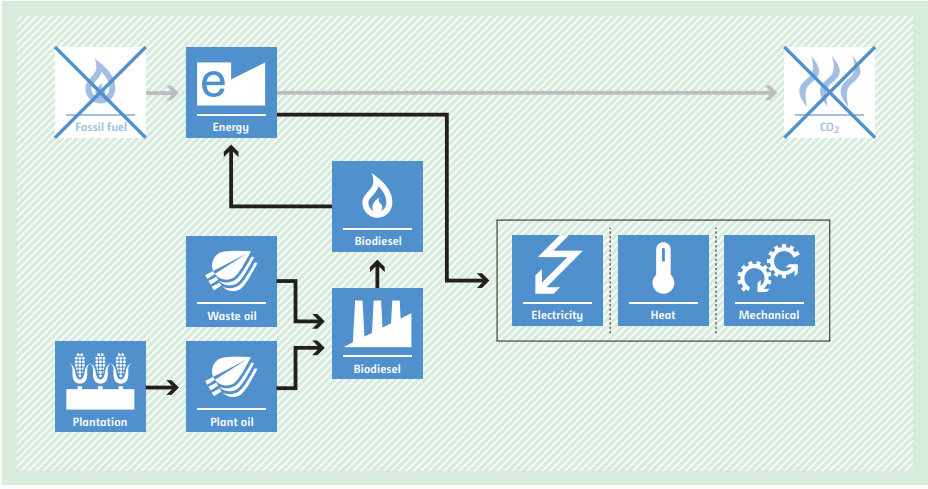
<p>Typical project(s)</p>	<p>Biodiesel is produced from oilseeds cultivated on dedicated plantations and from waste oil/fat and used to generate thermal; mechanical or electrical energy in equipment including cogeneration.</p>
<p>Type of GHG emissions mitigation action</p>	<ul style="list-style-type: none"> • Renewable energy. • Displacement of more-GHG-intensive fossil fuel for combustion in stationary installations.
<p>Important conditions under which the methodology is applicable</p>	<ul style="list-style-type: none"> • The pure biodiesel and its blends above 10% is used in specially built or modified equipment; • The alcohol used for esterification is methanol from fossil fuel origin; • Export of produced biodiesel is not allowed; • Oil crops are cultivated on area which is classified as degraded or degrading as per the “Tool for the identification of degraded or degrading lands for consideration in implementing CDM A/R project” or on area included in the project boundary of one or several registered A/R CDM project activities. Plantations established on peatlands are not eligible.
<p>Important parameters</p>	<p>Monitored:</p> <ul style="list-style-type: none"> • Energy consumption of the combustion processes (e.g. biodiesel, fossil fuel); • Parameters to estimate project emissions from the cultivation of oil crops if the default values for jatropha and palm oil are not applied; • If applicable: leakage emissions due to a shift of pre-project activities and the competing uses of biomass; • Quantity of the electricity produced; of the thermal energy (mass flow, temperature, pressure for heat/cooling) generated by the project; • Project emissions from fossil fuel and electricity consumption as well as from the transport of oilseeds if distances of more than 200 km are covered.
<p>BASELINE SCENARIO Services (e.g. electricity, thermal and mechanical energy supply) are provided using fossil fuel based technologies.</p>	
<p>PROJECT SCENARIO Biodiesel is produced from cultivated oil crops or from waste oil/fat and used for the generation of electricity, thermal or mechanical energy displacing fossil fuel.</p>	

AMS-I.I. Biogas/biomass thermal applications for households/small users



<p>Typical project(s)</p>	<p>Activities for generation of renewable thermal energy using renewable biomass or biogas for use in residential, commercial and institutional applications. Examples of these technologies that displace or avoid fossil fuel use include, but are not limited to, biogas cook stoves, biomass briquette cook stoves, small-scale baking and drying systems, water heating, or space heating systems.</p>
<p>Type of GHG emissions mitigation action</p>	<ul style="list-style-type: none"> • Renewable energy. • Displacement of more-GHG-intensive thermal energy generation.
<p>Important conditions under which the methodology is applicable</p>	<ul style="list-style-type: none"> • Each unit (e.g. cook stove, heater) shall have a rated capacity equal to or less than 150 kW thermal.
<p>Important parameters</p>	<p>Monitored:</p> <ul style="list-style-type: none"> • Number of thermal applications commissioned; • Proportion of thermal applications that remain operating in year y; • Annual consumption of fossil fuel in the baseline and project; • The net quantity of renewable biomass or biogas consumed by the thermal application in year y; • Net calorific value of biomass type.
<p>BASILINE SCENARIO Thermal energy production based on fossil fuel.</p>	<pre> graph LR FF[Fossil fuel] --> H1[Heat] H1 --> C[Consumer] H1 --> CO2[CO2] </pre>
<p>PROJECT SCENARIO Thermal energy generation by renewable biomass or biogas. Fossil fuel may continue to be used.</p>	<pre> graph LR subgraph Inputs B[Biomass] BG[Biogas] end FF[Fossil fuel] R[Renewable] E[Energy] H[Heat] C[Consumer] CO2[CO2] B --> R BG --> R FF --> E R --> H E --> H H --> C H --> CO2 </pre>



AMS-I.J. Solar water heating systems (SWH)

<p>Typical project(s)</p>	<p>The installation of residential and commercial solar water heating (SWH) systems for hot water production.</p>
<p>Type of GHG emissions mitigation action</p>	<ul style="list-style-type: none"> Renewable energy. <p>Displacement of electricity or fossil fuel that would otherwise have been used to produce hot water.</p>
<p>Important conditions under which the methodology is applicable</p>	<ul style="list-style-type: none"> Two types of projects included in this category: retrofits and new construction; Commercial SWH systems shall include operational indicators that may be easily interpreted by the intended users of the systems and that indicate that water is being heated by solar energy.
<p>Important parameters</p>	<p>At validation:</p> <ul style="list-style-type: none"> Emission factor of the baseline fuel and/or grid; Where applicable: <ul style="list-style-type: none"> Efficiency of the baseline unit which is consuming fossil fuel or electricity; Solar insolation level; Time of hot water demand. <hr/> <p>Monitored:</p> <ul style="list-style-type: none"> Where applicable, hot water consumption pattern, inlet/outlet temperature, characteristics/specifications of the project system; Retention rate of the project system; Collecting area of the solar panel; Auxiliary fuel consumption by the project system, where applicable.
<p>BASELINE SCENARIO Hot water production is based on fossil fuel/electricity consumption.</p>	<pre> graph LR FF[Fossil fuel] --> H[Heat] H --> W[Water] H --> H2[Heat] W --> HW[Hot Water] H2 --> HW H --> CO2[CO2] </pre>
<p>PROJECT SCENARIO Hot water is produced by solar energy.</p>	<pre> graph LR R[Renewable] --> H[Heat] FF[Fossil fuel] --> H H --> W[Water] H --> H2[Heat] W --> HW[Hot Water] H2 --> HW H --> CO2[CO2] </pre>



AMS-I.K. Solar cookers for households

<p>Typical project(s)</p>	<p>Project activities that introduce solar cookers to individual households to be used for household cooking purpose.</p>
<p>Type of GHG emissions mitigation action</p>	<ul style="list-style-type: none"> • Renewable energy. <p>Use of solar cookers will reduce or displace use of fossil fuels or non-renewable biomass.</p>
<p>Important conditions under which the methodology is applicable</p>	<ul style="list-style-type: none"> • Solar cookers shall be demonstrated to be designed and constructed according to the requirements of a relevant national or international standard; • A local organization shall be involved on an ongoing basis to assist in promoting and facilitating the continued use of the cookers.
<p>Important parameters</p>	<p>At validation:</p> <ul style="list-style-type: none"> • Annual consumption of baseline fossil fuel (can also be monitored). <hr/> <p>Monitored:</p> <ul style="list-style-type: none"> • Number of households provided with solar cookers; • Proportion of provided solar cookers still operating.
<p>BASELINE SCENARIO Fossil fuel(s) or non-renewable biomass are used for cooking purposes.</p>	<pre> graph LR FF[Fossil fuel] --> H1[Heat] H1 --> H2[Heat] H2 --> C[Consumer] H2 --> CO2[CO2] </pre>
<p>PROJECT SCENARIO Fossil fuel(s) or non-renewable biomass are replaced by solar energy.</p>	<pre> graph LR FF[Fossil fuel] --> H1[Heat] R[Renewable] --> H1 H1 --> H2[Heat] H2 --> C[Consumer] H2 --> CO2[CO2] </pre>

AMS-I.L. Electrification of rural communities using renewable energy



<p>Typical project(s)</p>	<p>After the project implementation, rural communities are supplied with electricity from renewable-based systems (e.g. solar home systems, renewable mini-grid).</p>
<p>Type of GHG emissions mitigation action</p>	<ul style="list-style-type: none"> • Renewable energy. • Displacement of fossil fuel use.
<p>Important conditions under which the methodology is applicable</p>	<ul style="list-style-type: none"> • 75 % (by numbers) of the end-users shall be households; • End-users were not connected to a national/regional grid; • Project equipment complies with international standards or comparable national, regional or local standards/guidelines.
<p>Important parameters</p>	<p>At validation:</p> <ul style="list-style-type: none"> • The number of facilities (e.g. households, SMMEs, public buildings) supplied with renewable electricity by the project activity. <p>Monitored:</p> <ul style="list-style-type: none"> • Measure or estimate the net amount of renewable electricity delivered to all the end-use facilities; • Installed capacity of renewable electricity generation systems.
<p>BASELINE SCENARIO In the absence of the project activity, the end users would have used fossil fuel based lighting and stand-alone diesel electricity generators for appliances other than lighting (e.g. TV).</p>	<p>The diagram shows a flow from 'Fossil fuel' (flame icon) to 'Lighting' (lightbulb icon) and 'Power plant' (factory icon). The 'Power plant' also produces 'Electricity' (lightning bolt icon). Both 'Lighting' and 'Electricity' are supplied to a 'Consumer' (house and factory icon). The 'Consumer' then produces 'CO2' (flame icon).</p>
<p>PROJECT SCENARIO End users are supplied with electricity from renewable based energy systems (e.g. solar home systems or renewable mini-grid).</p>	<p>The diagram shows a flow from 'Renewable' (solar panel icon) to 'Lighting' and 'Electricity'. The 'Power plant' (factory icon) is crossed out with a blue 'X', and 'Fossil fuel' (flame icon) is also crossed out. An 'Upgrade' (gear icon) box is positioned above the 'Lighting' box. The 'Consumer' (house and factory icon) receives electricity from both 'Lighting' and 'Electricity'. The 'CO2' (flame icon) output is significantly reduced, indicated by a blue 'X' over the icon.</p>

AMS-II.A. Supply side energy efficiency improvements – transmission and distribution

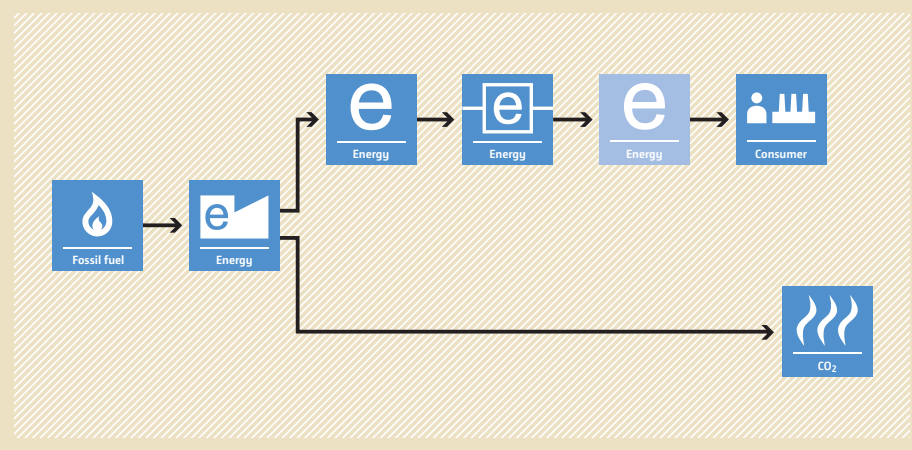
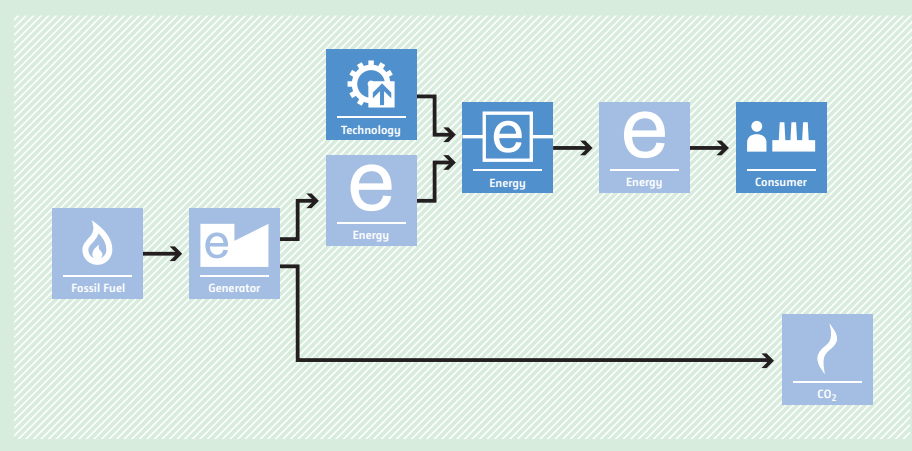
<p>Typical project(s)</p>	<p>Technical energy losses are reduced through energy efficiency measures such as upgrading the voltage on a transmission/distribution system, replacing existing transformers with more efficient transformers (e.g. replacement of a silicon steel core transformer with an amorphous metal transformer) in electrical transmission/distribution system or improving pipe insulation in a district heating system. The project may be the upgrade/replacement of an existing distribution system or be part of an expansion of an existing system.</p>
<p>Type of GHG emissions mitigation action</p>	<ul style="list-style-type: none"> • Energy efficiency. <p>Technology with higher efficiency reduces electrical or thermal energy losses and thereby GHG emissions.</p>
<p>Important conditions under which the methodology is applicable</p>	<ul style="list-style-type: none"> • Measures that reduce technical losses solely by improving operations and/or maintenance practices are not eligible; • Introduction of capacitor banks and tap changing transformers for reducing losses in an electricity distribution is not covered; • For retrofit projects, historical data is required to determine technical losses of the existing equipment.
<p>Important parameters</p>	<p>Monitored:</p> <ul style="list-style-type: none"> • Technical energy losses of the project equipment; • If applicable: for radial electricity distribution systems for which no performance-measuring standards are available, technical losses shall be determined by a peer reviewed method.
<p>BASELINE SCENARIO Electrical/thermal energy is transmitted and distributed using less-efficient energy system.</p>	 <p>The baseline scenario flowchart (yellow background) shows the flow of energy from 'Fossil fuel' (flame icon) to 'Energy' (e icon). From this 'Energy' node, the flow splits into two paths: one goes through three sequential 'Energy' (e icon) boxes representing transmission and distribution stages, and the other goes directly to 'CO2' (flame icon). The final 'Energy' box leads to a 'Consumer' (factory icon). This represents a less-efficient system with high technical losses.</p>
<p>PROJECT SCENARIO Reducing technical losses and thereby GHG emissions through installation of a new energy-efficient distribution/transmission equipment/system and/or retrofit of the existing less-efficient equipment/system.</p>	 <p>The project scenario flowchart (green background) shows the flow of energy from 'Fossil Fuel' (flame icon) to 'Generator' (e icon). From the 'Generator', the flow splits into two paths: one goes through a 'Technology' (gear icon) box and then an 'Energy' (e icon) box, and the other goes directly to 'CO2' (flame icon). The 'Technology' box represents the energy efficiency improvement. The final 'Energy' box leads to a 'Consumer' (factory icon). This represents a more efficient system with reduced technical losses.</p>

AMS-II.B. Supply side energy efficiency improvements – generation

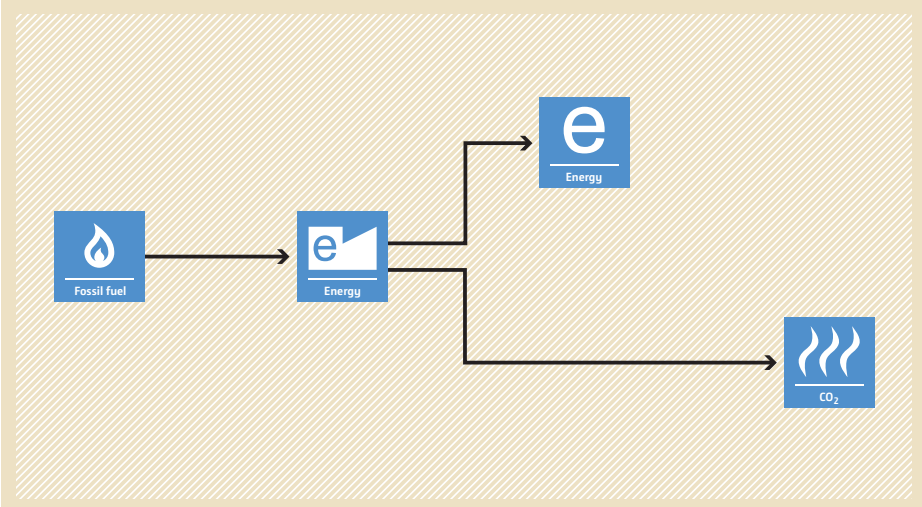
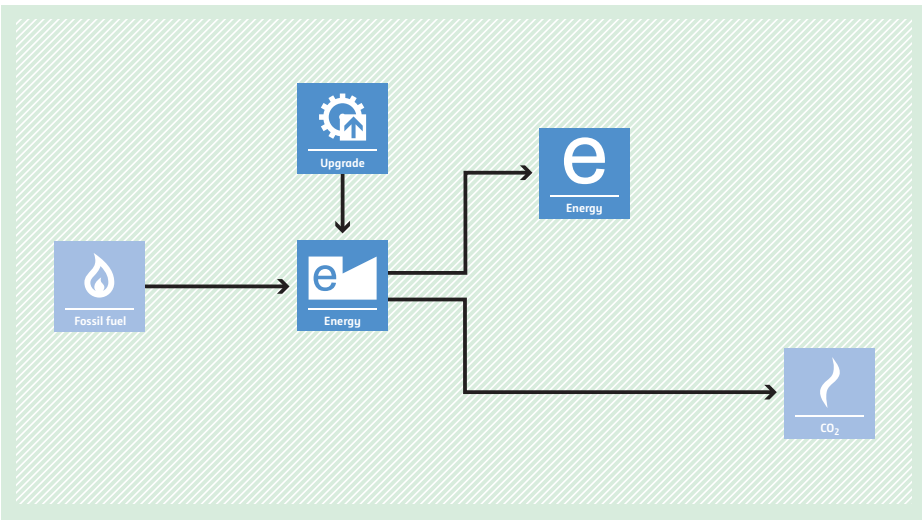
<p>Typical project(s)</p>	<p>Introduction of more-efficient electricity and/or thermal energy generation units or complete replacement of existing power stations, district heating plants and cogeneration units by new equipment with a higher efficiency or retrofitting of existing fossil-fuel-fired generating units in order to increase their efficiency.</p>
<p>Type of GHG emissions mitigation action</p>	<ul style="list-style-type: none"> • Energy efficiency. <p>Technology with higher efficiency reduces fossil fuel consumption for energy generation and thereby reduces GHG emissions.</p>
<p>Important conditions under which the methodology is applicable</p>	<ul style="list-style-type: none"> • Baseline and project technologies utilize fossil fuels to produce energy; • Renewable energy projects are not applicable (type I methodologies e.g. AMS-I.C. or AMS-I.D. may be explored).
<p>Important parameters</p>	<p>Monitored:</p> <ul style="list-style-type: none"> • Quantity of fuel used in the energy generating equipment; • Quantity of energy output.
<p>BASELINE SCENARIO Continuation of the current situation; i.e. use of the existing fossil-fuel-fired energy generation equipment with lower efficiency.</p>	 <p>The diagram illustrates the baseline scenario. It starts with a box labeled 'Fossil fuel' with a flame icon. An arrow points to a box labeled 'Energy' with a low-efficiency 'e' icon. From this 'Energy' box, two arrows branch out: one points to a box labeled 'Energy' with a high-efficiency 'e' icon, and the other points to a box labeled 'CO2' with a flame icon.</p>
<p>PROJECT SCENARIO Installation of more-efficient energy generation technology and/or complete replacement of existing less-efficient equipment and/or retrofitting of an existing energy generation system reduces fossil fuel consumption and GHG emissions.</p>	 <p>The diagram illustrates the project scenario. It starts with a box labeled 'Fossil fuel' with a flame icon. An arrow points to a box labeled 'Energy' with a high-efficiency 'e' icon. Above this 'Energy' box is a box labeled 'Upgrade' with a gear icon, and an arrow points from 'Upgrade' to the 'Energy' box. From the 'Energy' box, two arrows branch out: one points to a box labeled 'Energy' with a high-efficiency 'e' icon, and the other points to a box labeled 'CO2' with a flame icon.</p>

AMS-II.C. Demand-side energy efficiency activities for specific technologies



<p>Typical project(s)</p>	<p>Installation of new energy-efficient equipment (e.g. lamps, ballasts, refrigerators, motors, fans, air conditioners, pumping systems and chillers) at one or more project sites, as retrofit or new construction (Greenfield) projects.</p>
<p>Type of GHG emissions mitigation action</p>	<ul style="list-style-type: none"> • Energy efficiency. • Displacement of more-GHG-intensive service by use of more-efficient technology.
<p>Important conditions under which the methodology is applicable</p>	<ul style="list-style-type: none"> • The service level (e.g. rated capacity or output) of the installed project energy-efficient equipment is between 90% and 150% of the service level of the baseline equipment; • If applicable: refrigerant used in the project activity shall have no ozone depleting potential (ODP).
<p>Important parameters</p>	<p>At validation:</p> <ul style="list-style-type: none"> • If applicable: grid emission factor (can also be monitored ex post). <p>Monitored:</p> <ul style="list-style-type: none"> • Monitoring shall include annual checks of a sample of non-metered systems to ensure that they are still operating; • Recording the “power” of the equipment installed and metering a sample of the units installed for their operating hours using run time meters; or metering the “energy use” of an appropriate sample of the equipment installed.
<p>BASELINE SCENARIO Less-efficient equipment (e.g. lamps, refrigerators, motors, fans, air conditioners, pumping systems, chillers) consume more energy, thus resulting in higher GHG emissions.</p>	<pre> graph LR FF[Fossil fuel] --> G[Grid] G --> E[Electricity] G --> CO2[CO2] E --> EQ[Equipment] </pre>
<p>PROJECT SCENARIO More-efficient equipment (e.g. lamps, refrigerators, motors, fans, air conditioners, pumping systems, chillers) consume less energy, thus resulting in lower GHG emissions.</p>	<pre> graph LR FF[Fossil fuel] --> G[Grid] G --> E[Electricity] G --> CO2[CO2] E --> EQ[Equipment] U[Upgrade] --> EQ </pre>

AMS-II.D. Energy efficiency and fuel switching measures for industrial facilities

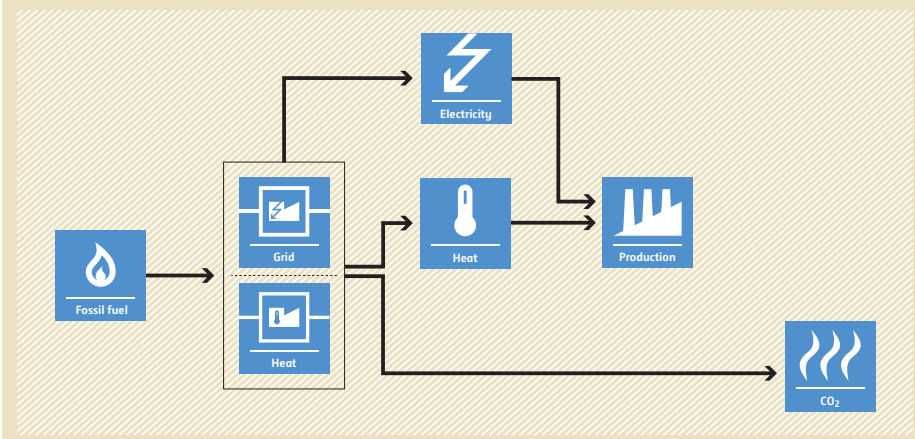
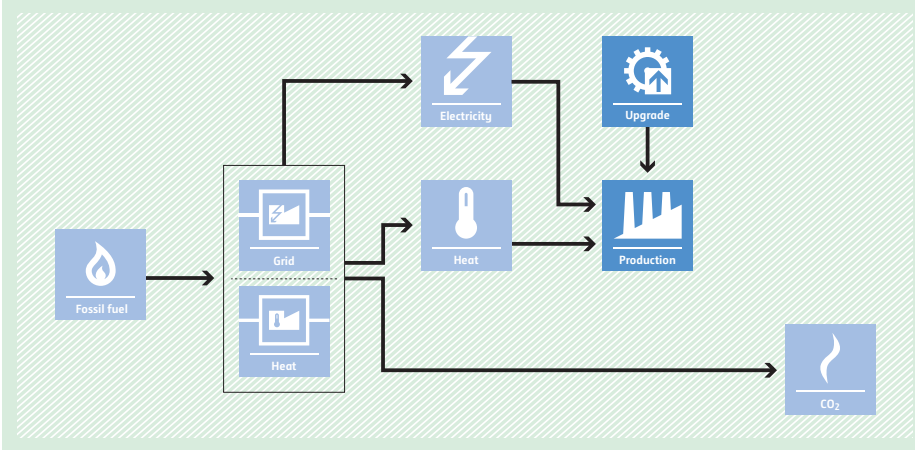
<p>Typical project(s)</p>	<ul style="list-style-type: none"> Process energy efficiency improvement(s) affecting either a single production step/element process (e.g. furnace, kiln) or a series of production steps/element processes (e.g. industrial process involving many machines); Energy efficiency improvement in energy conversion equipment (e.g. boiler, motor) that supplies thermal/electrical/mechanical energy within a facility.
<p>Type of GHG emissions mitigation action</p>	<ul style="list-style-type: none"> Energy efficiency. <p>Increase in energy efficiency with, optionally, a switch to less-carbon-intensive fuel.</p>
<p>Important conditions under which the methodology is applicable</p>	<ul style="list-style-type: none"> Energy use within the project boundary can be directly measured or can be determined using national/international standards; Improvements in efficiency by the project can be clearly distinguished from efficiency changes/improvements not attributable to the project; The project output is equivalent to the output produced in the baseline.
<p>Important parameters</p>	<p>At validation:</p> <ul style="list-style-type: none"> Energy consumption, emission intensity of energy types, output service level in the baseline; Documenting of the technical specification of the equipment/systems. <hr/> <p>Monitored:</p> <ul style="list-style-type: none"> Metering the energy use of equipments; Output; In case the output parameter cannot be measured, the quantity of input material (feedstock).
<p>BASELINE SCENARIO Consumption of electricity, heat and/or fossil fuel leads to CO₂ emissions.</p>	 <p>The diagram illustrates the baseline scenario. It starts with 'Fossil fuel' (represented by a flame icon) entering a central box labeled 'Grid' and 'Heat'. From this box, three arrows branch out: one to 'Electricity' (lightning bolt icon), one to 'Heat' (thermometer icon), and one to 'Production' (factory icon). The 'Production' box then has an arrow pointing to 'CO₂' (flame icon). The entire process is set against a light brown background.</p>
<p>PROJECT SCENARIO Consumption of less electricity, heat and/or fossil fuel leads to decreased CO₂ emissions.</p>	 <p>The diagram illustrates the project scenario. It follows the same flow as the baseline scenario, but with an additional 'Upgrade' box (gear icon) placed between the 'Electricity' and 'Production' boxes. An arrow points from 'Upgrade' to 'Production'. The 'Production' box then has an arrow pointing to 'CO₂' (flame icon). The entire process is set against a light green background, indicating a reduction in emissions compared to the baseline.</p>

AMS-II.E. Energy efficiency and fuel switching measures for buildings



<p>Typical project(s)</p>	<p>Installation of, or replacement or retrofit of, existing equipment with energy efficiency (e.g. efficient appliances, better insulation) and optional fuel switching (e.g. switch from oil to gas) measures in residential, commercial or institutional buildings.</p>
<p>Type of GHG emissions mitigation action</p>	<ul style="list-style-type: none"> • Energy efficiency. <p>Electricity and/or fuel savings through energy efficiency improvement. Optionally, use of less-carbon-intensive fuel.</p>
<p>Important conditions under which the methodology is applicable</p>	<ul style="list-style-type: none"> • Energy use within the project boundary shall be directly measured; • The impact of the implemented measures (improvements in energy efficiency) can be clearly distinguished from changes in energy use due to other variables not influenced by the project.
<p>Important parameters</p>	<p>At validation:</p> <ul style="list-style-type: none"> • Energy use of buildings before the project implementation; • If grid electricity is consumed: grid emission factor (can also be monitored ex post). <p>Monitored:</p> <ul style="list-style-type: none"> • Specifications of the equipment replaced or retrofitted (only for replacement or retrofit projects); • Energy use of buildings after the project implementation.
<p>BASELINE SCENARIO Use of less-efficient and/or more-carbon-intensive equipment in buildings.</p>	<p>The diagram shows a linear flow from left to right. On the left is a blue square icon with a flame and the text 'Fossil fuel'. An arrow points to a central blue square icon with a building and the text 'Buildings'. Another arrow points to a rightmost blue square icon with three wavy lines and the text 'CO2'. The entire flow is set against a light brown background with a diagonal hatching pattern.</p>
<p>PROJECT SCENARIO Use of more-efficient and/or less-carbon-intensive equipment in buildings.</p>	<p>The diagram shows a flow from left to right. On the left is a blue square icon with a flame and the text 'Fossil fuel'. An arrow points to a central blue square icon with a building and the text 'Buildings'. Another arrow points to a rightmost blue square icon with three wavy lines and the text 'CO2'. Above the 'Buildings' icon is a blue square icon with a gear and a house, with the text 'Upgrade'. An arrow points from the 'Upgrade' icon down to the 'Buildings' icon. The entire flow is set against a light green background with a diagonal hatching pattern.</p>

AMS-II.F. Energy efficiency and fuel switching measures for agricultural facilities and activities



<p>Typical project(s)</p>	<p>Energy efficiency and fuel switching measures implemented in agricultural activities or facilities or processes. Examples for such measures are efficient irrigation (e.g. adoption of drip/sprinkler irrigation to substitute flood irrigation), measures leading to a reduced requirement of farm power per unit area of land, as well as reducing fuel consumption in agriculture, such as reduced machinery use through, (e.g. elimination of tillage operations).</p>
<p>Type of GHG emissions mitigation action</p>	<ul style="list-style-type: none"> • Energy efficiency; • Fuel switch. <p>Displacement of more-GHG-intensive agricultural service(s).</p>
<p>Important conditions under which the methodology is applicable</p>	<ul style="list-style-type: none"> • Installation of new equipment and/or retrofit of existing equipment is eligible; • Baseline and project scenarios of fuel consumption shall be demonstrated against reference agriculture activities, including cultivated average and crop yield.
<p>Important parameters</p>	<p>Monitored:</p> <ul style="list-style-type: none"> • Applicable for retrofits: the energy use of the agriculture facility, processes or the equipment affected; • Applicable for installation of new equipment: the energy use of the agriculture facility, processes or the equipment installed; • The characteristics and scale of the agriculture activities such as number of ha cultivated, crop yield.
<p>BASELINE SCENARIO Installation and use of less-efficient agriculture facilities, processes and equipment.</p>	<p>The baseline scenario flowchart shows a linear process. On the left, a blue box contains a flame icon and the text 'Fossil fuel'. An arrow points from this box to a central box. The central box is divided into two sections: the top section contains a tractor icon and 'Agr. activity', and the bottom section contains a crop icon and 'Agriculture'. A second arrow points from the central box to a final blue box on the right containing a flame icon and 'CO2'.</p>
<p>PROJECT SCENARIO Due to retrofitting and/or new installations, more-efficient agriculture facilities, processes and equipment are utilized resulting in reduced GHG emissions.</p>	<p>The project scenario flowchart shows a more complex process. On the left, two blue boxes are stacked vertically, each containing a flame icon and the text 'Fossil fuel'. An arrow points from these boxes to a central box. Above this central box is a blue box containing a gear icon and the text 'Upgrade', with a downward arrow pointing to the central box. The central box is divided into two sections: the top section contains a tractor icon and 'Agr. activity', and the bottom section contains a crop icon and 'Agriculture'. A second arrow points from the central box to a final blue box on the right containing a flame icon and 'CO2'.</p>

AMS-II.G. Energy efficiency measures in thermal applications of non-renewable biomass



<p>Typical project(s)</p>	<p>Introduction of high-efficient thermal energy generation units e.g. efficient biomass fired cook stoves or ovens or dryers to reduce the use of non-renewable biomass.</p>
<p>Type of GHG emissions mitigation action</p>	<ul style="list-style-type: none"> • Energy efficiency. <p>Displacement or energy efficiency enhancement of existing heat generation units results in saving of non-renewable biomass and reduction of GHG emissions.</p>
<p>Important conditions under which the methodology is applicable</p>	<ul style="list-style-type: none"> • It shall be demonstrated that non-renewable biomass has been used since 31 December 1989; • Project participants shall determine the share of renewable and non-renewable woody biomass (fNRB) in the quantity of woody biomass used in the absence of the project. Default country specific fNRB values available on the CDM website may be used; • The methodology is applicable to single pot or multi pot portable or in-situ cook stoves with rated efficiency of at least 20 per cent.
<p>Important parameters</p>	<p>Monitored:</p> <ul style="list-style-type: none"> • Annual or biennial check of operation of the project appliances (e.g. by representative sample); • Annual check of the efficiency of the project appliances (e.g. by representative sample). Alternatively, the result of a sample survey of the first batch may be used as a proxy to subsequent batches; • Leakage: the amount of woody biomass saved under the project that is used by non-project households/users (who previously used renewable energy sources) shall be assessed from surveys.
<p>BASELINE SCENARIO Continuation of the current situation; i.e. use of non-renewable biomass as fuel for the existing, less-efficient thermal applications.</p>	<pre> graph LR A[Non-renewable] --> B[Heat] B --> C[Heat] B --> D[CO2] </pre>
<p>PROJECT SCENARIO Installation of more-efficient thermal energy generation units utilizing non-renewable biomass and/or complete replacement of existing less-efficient thermal applications and/or retrofitting of existing thermal energy generating appliances reduces GHG emissions by saving non-renewable biomass.</p>	<pre> graph TD A[Non-renewable] --> B[Heat] Upgrade[Upgrade] --> B B --> C[Heat] B --> D[CO2] </pre>

AMS-II.H. Energy efficiency measures through centralization of utility provisions of an industrial facility

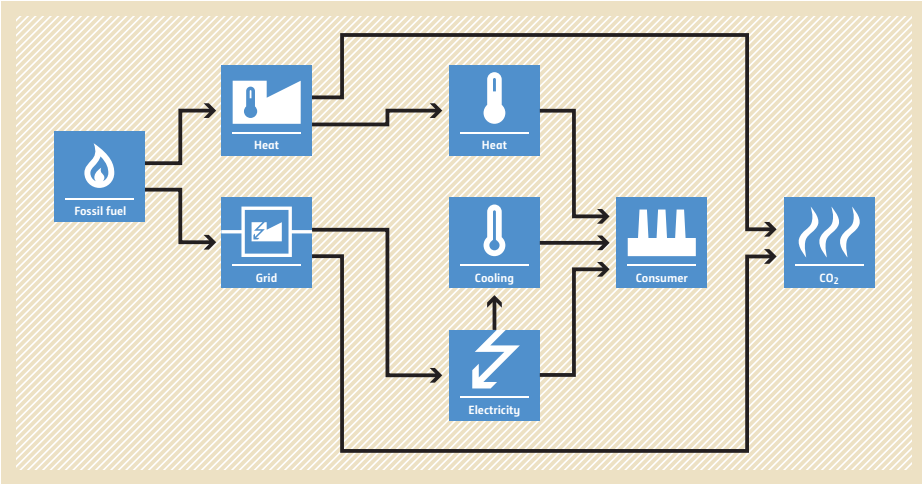
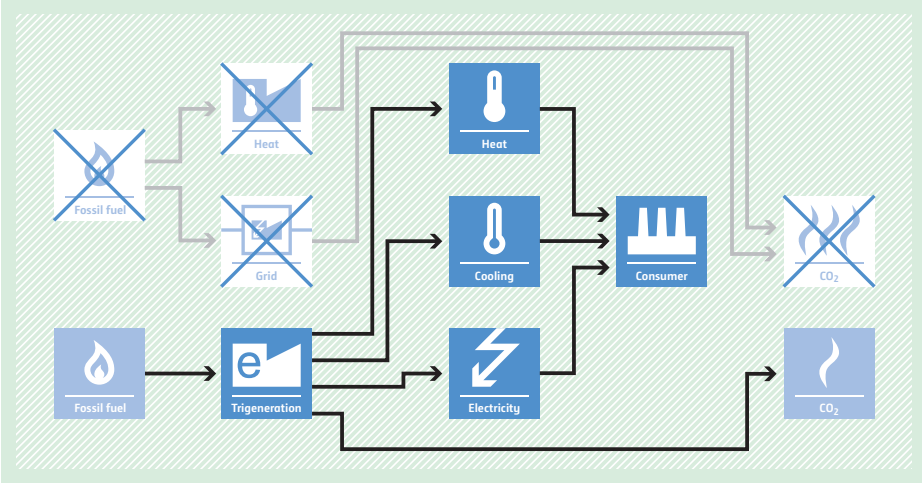
<p>Typical project(s)</p>	<p>Energy efficiency measures implemented through integration of a number of utility provisions into one single utility to produce power and heat and/or cooling (i.e. cogeneration/trigeneration systems) in an existing or new industrial facility.</p>
<p>Type of GHG emissions mitigation action</p>	<ul style="list-style-type: none"> • Energy efficiency. • Displacement of several more-GHG-intensive utilities by a single, centralized utility.
<p>Important conditions under which the methodology is applicable</p>	<ul style="list-style-type: none"> • Displacement of cogeneration or trigeneration systems is not allowed; • For existing system, three years of historical data is required; • Definition of natural gas applies; • Project equipment containing refrigerants shall have no global warming potential and no ozone depleting potential.
<p>Important parameters</p>	<p>At validation:</p> <ul style="list-style-type: none"> • Definition of a reference baseline plant that would have been built in absence of the project; • Grid emission factor (can also be monitored ex post). <p>Monitored:</p> <ul style="list-style-type: none"> • Amount of electricity supplied to the industrial facility and/or the grid; • Quantity of fossil fuel and grid electricity consumed by the project; • Electrical and thermal energy delivered by the project.
<p>BASELINE SCENARIO Production of power/heat/cooling in separate element processes, e.g. grid and/or captive fossil-fuel-fired power plant, fossil-fuel-fired boiler for heat and electrical compression chillers for cooling.</p>	 <p>The diagram illustrates the baseline scenario where utilities are produced separately. Fossil fuel is converted into heat and grid electricity. The grid electricity is used to produce cooling. Heat and cooling are then used by a consumer, which also uses grid electricity. This process results in CO2 emissions.</p>
<p>PROJECT SCENARIO Simultaneous production of power/heat/cooling energy using cogeneration/trigeneration system, thus saving energy and reducing GHG emissions.</p>	 <p>The diagram illustrates the project scenario where power, heat, and cooling are produced simultaneously using a trigeneration system. Fossil fuel is used to generate heat, cooling, and electricity simultaneously. The heat and cooling are used by a consumer, which also uses electricity. This process results in reduced CO2 emissions compared to the baseline scenario.</p>

AMS-II.I. Efficient utilization of waste energy in industrial facilities

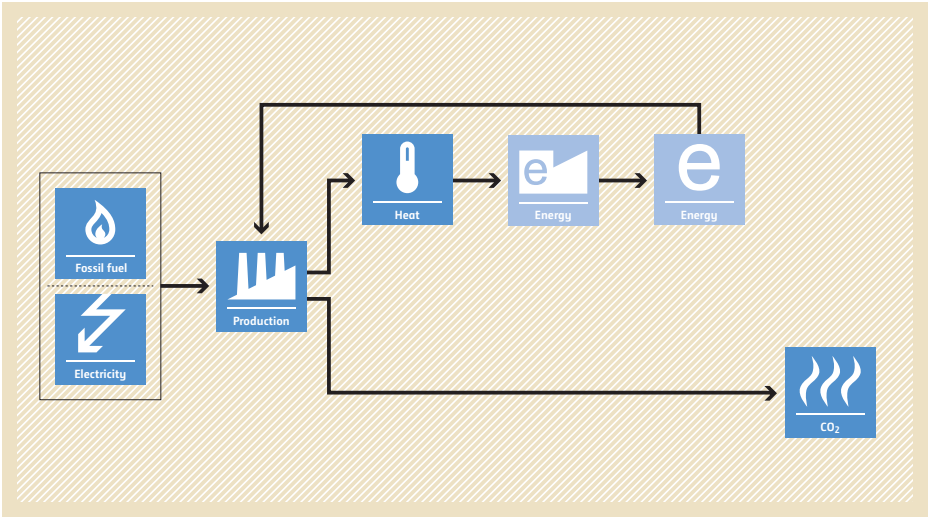
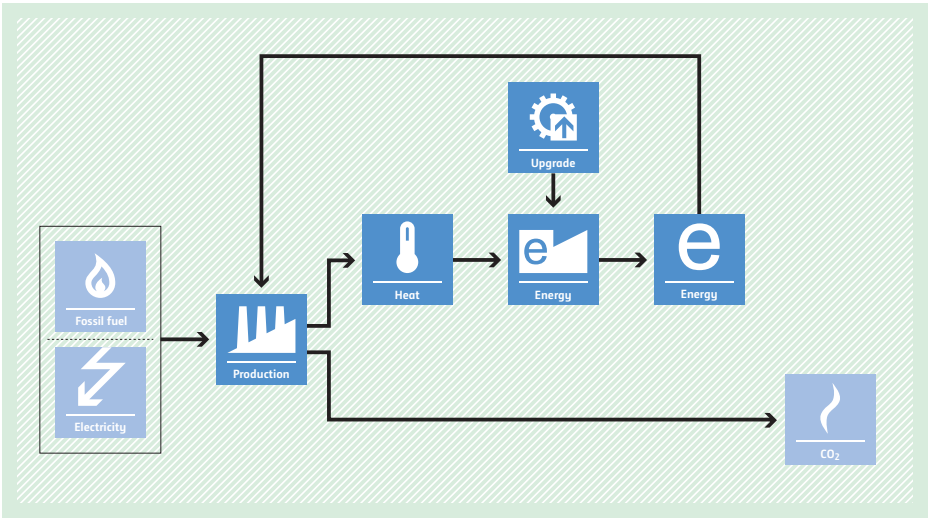
<p>Typical project(s)</p>	<p>Energy efficiency improvement of an electricity or thermal energy generation unit, which is based on recovery of waste energy from a single source at an industrial, mining or mineral production facility.</p>
<p>Type of GHG emissions mitigation action</p>	<ul style="list-style-type: none"> • Energy efficiency. <p>Enhancement of waste energy recovery to replace more-GHG-intensive service.</p>
<p>Important conditions under which the methodology is applicable</p>	<ul style="list-style-type: none"> • Production process and production outputs are homogenous in the baseline and project scenario; • Improvements in efficiency in the project are clearly distinguishable from other variables not attributable to the project; • There is no auxiliary fuel and/or co-firing for energy generation; • Methodology is not applicable to retrofitting of existing facilities to increase production outputs.
<p>Important parameters</p>	<p>At validation:</p> <ul style="list-style-type: none"> • Energy generation ratio of baseline equipment. <p>Monitored:</p> <ul style="list-style-type: none"> • Energy produced and consumed by the generating unit; • Production output of the facility.
<p>BASELINE SCENARIO Continuation of the use of a less-efficient waste energy recovery system.</p>	 <p>The diagram illustrates the baseline scenario. On the left, a box contains 'Fossil fuel' (flame icon) and 'Electricity' (lightning bolt icon). An arrow points to a 'Production' unit (factory icon). From the production unit, an arrow goes to a 'Heat' unit (thermometer icon). From the heat unit, an arrow goes to an 'Energy' unit (e icon). From this energy unit, an arrow goes to another 'Energy' unit (e icon). A separate arrow from the production unit goes to a 'CO2' unit (flame icon). The entire process is enclosed in a light brown shaded area.</p>
<p>PROJECT SCENARIO Use of a more-efficient waste energy recovery system, thus leading to higher energy gains and thereby replacement of energy provided by more-GHG-intensive means.</p>	 <p>The diagram illustrates the project scenario. It is identical to the baseline scenario, but with an 'Upgrade' unit (gear icon) positioned above the first 'Energy' unit. An arrow points from the 'Upgrade' unit to the first 'Energy' unit. This upgrade results in a smaller 'CO2' unit (flame icon) compared to the baseline. The entire process is enclosed in a light green shaded area.</p>

AMS-II.J. Demand-side activities for efficient lighting technologies



<p>Typical project(s)</p>	<p>Activities for adoption of self-ballasted compact fluorescent lamps (CFLs) to replace incandescent lamps (ICLs) in residential applications.</p>
<p>Type of GHG emissions mitigation action</p>	<ul style="list-style-type: none"> • Energy efficiency. <p>Displacement of more-GHG-intensive lighting by technology switch.</p>
<p>Important conditions under which the methodology is applicable</p>	<ul style="list-style-type: none"> • Total lumen output of the CFL should be equal to or more than that of the ICL being replaced and CFLs shall, in addition to the standard lamp specifications, be marked for clear unique identification for the project; • Average life or rated average life of the CFLs shall be known ex ante. IEC 60969 (Self Ballasted Lamps for General Lighting Services - Performance Requirements) or an equivalent national standard shall be used to determine the average life; • If cumulative failure of CFLs exceeds 50% of total number of CFLs installed by the project, then the project ceases to issue CERs not issue anymore CERs; • Determination of daily operating hours: either default value of 3.5 hours or measured value.
<p>Important parameters</p>	<p>At validation:</p> <ul style="list-style-type: none"> • Average life time of the CFL (can also be monitored ex post); • The number and power of the replaced ICLs; • Number of ICLs distributed under the project, identified by the type of ICL and the date of supply; • Grid emission factor (can also be monitored ex post). <p>Monitored:</p> <ul style="list-style-type: none"> • If applicable: measurement of average daily operating hours; • Lamp failure rate surveys.
<p>BASELINE SCENARIO Incandescent lamps (ICLs) are used for lighting in households.</p>	<pre> graph LR FF[Fossil fuel] --> G[Grid] G --> E[Electricity] G --> CO2[CO2] E --> L[Lighting] </pre>
<p>PROJECT SCENARIO CFLs for lighting in households replace ICLs thus reducing electricity consumption and GHG emissions.</p>	<pre> graph LR FF[Fossil fuel] --> G[Grid] G --> E[Electricity] G --> CO2[CO2] E --> U[Upgrade] U --> L[Lighting] </pre>

AMS-II.K. Installation of co-generation or tri-generation systems supplying energy to commercial buildings

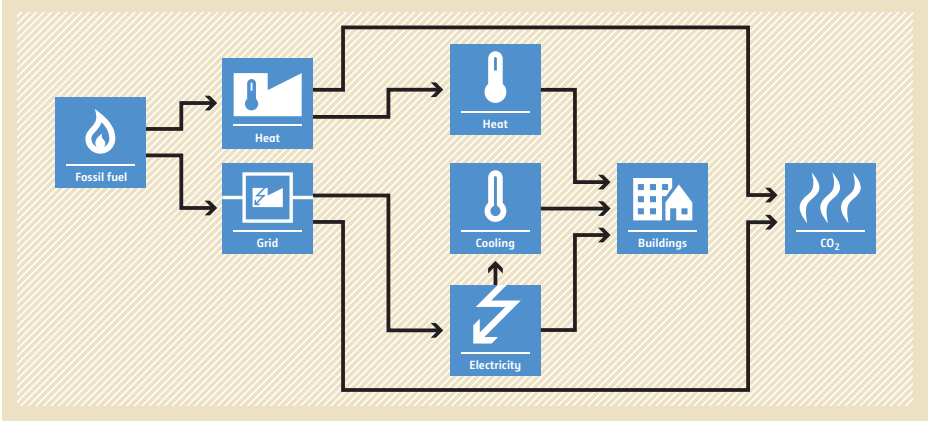
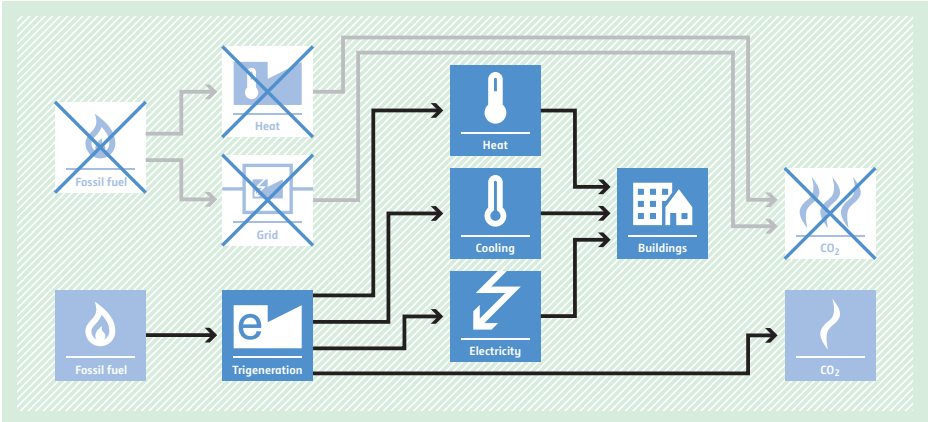
<p>Typical project(s)</p>	<p>Installation of fossil-fuel-based cogeneration or trigeneration systems. Generated electricity and cooling, and/or heating are supplied to commercial, non-industrial buildings.</p>
<p>Type of GHG emissions mitigation action</p>	<ul style="list-style-type: none"> • Energy efficiency. • Electricity and/or fuel savings through energy efficiency improvement.
<p>Important conditions under which the methodology is applicable</p>	<ul style="list-style-type: none"> • Applicable to installation of new systems that replace or supplement existing systems that supply electricity (grid or on-site generation) and cooling (e.g. chillers) and/or heating systems (e.g. boilers) or electricity and cooling and/or heating systems that would have been built and utilized; • Not applicable to the replacement of existing cogeneration or trigeneration systems; • If it is identified that the baseline situation is the continued use of an existing system then the existing system must have been in operation for at least the immediately prior three years; • If project equipment contains refrigerants, these refrigerants shall have no ozone depleting potential.
<p>Important parameters</p>	<p>At validation:</p> <ul style="list-style-type: none"> • Grid emission factor (can also be monitored ex post) and/or baseline captive power plants; • Coefficient of Performance (COP) of baseline chillers; • Efficiency of baseline steam generation systems. <p>Monitored:</p> <ul style="list-style-type: none"> • Amount of grid and/or captive power supplied by the project; • Amount of cooling and/or heating energy supplied by the project.
<p>BASELINE SCENARIO Separate generation of power/heat/cooling supplied to commercial, non-industrial buildings.</p>	 <p>The diagram illustrates the baseline scenario where energy services are provided by separate systems. On the left, a 'Fossil fuel' icon (flame) feeds into two boxes: 'Heat' (thermometer) and 'Grid' (plug). The 'Heat' box also receives input from a 'Fossil fuel' icon. The 'Grid' box receives input from a 'Fossil fuel' icon. The 'Heat' box outputs to a 'Buildings' icon (house), and the 'Grid' box outputs to an 'Electricity' icon (lightning bolt). The 'Electricity' icon outputs to a 'Cooling' icon (thermometer with minus sign). The 'Cooling' icon outputs to the 'Buildings' icon. The 'Buildings' icon outputs to a 'CO2' icon (flame). The 'Electricity' icon also outputs to a 'CO2' icon. The entire process is enclosed in a yellow-bordered box.</p>
<p>PROJECT SCENARIO Simultaneous production of power/heat/cooling using a co- or trigeneration system for supplying commercial, non-industrial buildings.</p>	 <p>The diagram illustrates the project scenario where energy services are provided by a trigeneration system. On the left, a 'Fossil fuel' icon (flame) feeds into a 'Trigeneration' box (lightning bolt with 'e'). The 'Trigeneration' box outputs to three boxes: 'Heat' (thermometer), 'Cooling' (thermometer with minus sign), and 'Electricity' (lightning bolt). The 'Heat' box outputs to a 'Buildings' icon (house), and the 'Cooling' box outputs to the 'Buildings' icon. The 'Buildings' icon outputs to a 'CO2' icon (flame). The 'Electricity' box outputs to a 'CO2' icon. The 'Fossil fuel' icon also outputs to a 'CO2' icon. The 'Heat' and 'Grid' boxes from the baseline scenario are crossed out with a large 'X'. The entire process is enclosed in a green-bordered box.</p>

AMS-II.L. Demand-side activities for efficient outdoor and street lighting technologies

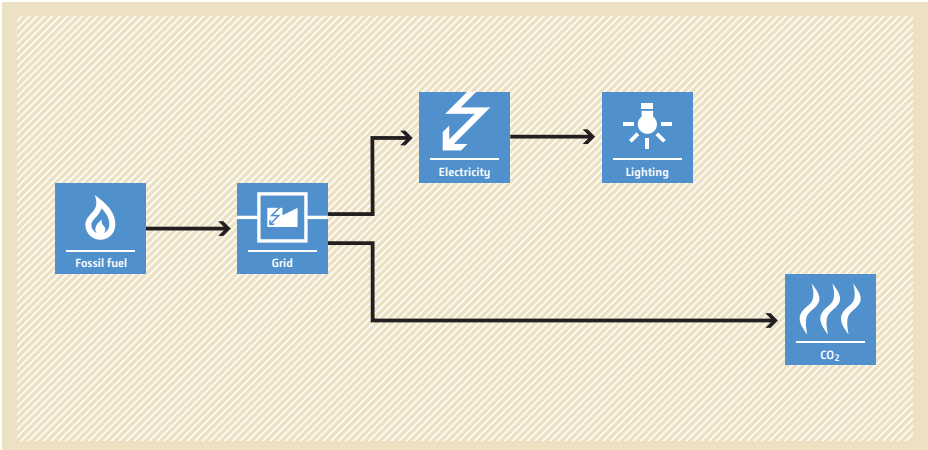
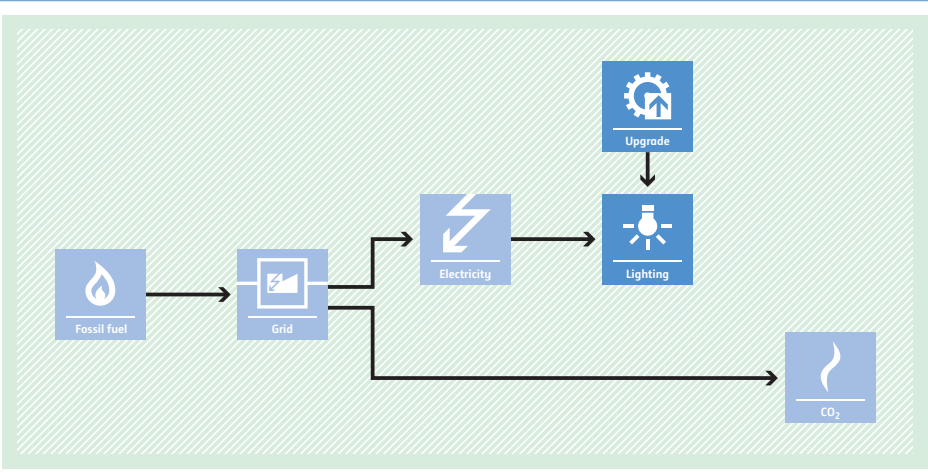
<p>Typical project(s)</p>	<p>Adoption of energy efficient lamps and/or fixture combinations to replace less efficient lamps and/or fixture combinations in public- or utility-owned street lighting systems.</p>
<p>Type of GHG emissions mitigation action</p>	<ul style="list-style-type: none"> • Energy Efficiency. <p>Displacement of less-efficient lighting by more-efficient technology.</p>
<p>Important conditions under which the methodology is applicable</p>	<ul style="list-style-type: none"> • Limited to public- or utility-owned street lighting systems; • Allows multiple-for-multiple lamps replacements; • Requires continuous replacement of failed lamps; • Includes new construction (Greenfield) installations; • Identify baseline technology for Greenfield, using the data from the region • Ensure that lighting performance quality of project lamps be equivalent or better than the baseline or applicable standard; • No mandatory destruction of replaced lamps required.
<p>Important parameters</p>	<p>Monitored:</p> <ul style="list-style-type: none"> • Average time elapsed between failure of luminaires and their replacement; • Annual failure rate; • Average annual operating hours; • Average project equipment power; • Number of project luminaires placed in service and operating under the project activity.
<p>BASELINE SCENARIO Less efficient lamps are used in street lighting systems.</p>	 <p>The diagram illustrates the baseline scenario. It starts with a 'Fossil fuel' icon (flame) on the left. An arrow points to a 'Grid' icon (power lines). From the 'Grid', an arrow points to an 'Electricity' icon (lightning bolt). From 'Electricity', an arrow points to a 'Lighting' icon (light bulb). A separate arrow from the 'Grid' points directly to a 'CO₂' icon (flame with wavy lines), representing emissions from the grid.</p>
<p>PROJECT SCENARIO Efficient lighting replaces less efficient lighting thus reducing electricity consumption and GHG emissions.</p>	 <p>The diagram illustrates the project scenario. It follows the same path as the baseline: 'Fossil fuel' to 'Grid' to 'Electricity' to 'Lighting'. However, an 'Upgrade' icon (gear with a house) is positioned above the 'Lighting' icon, with an arrow pointing down to it. This indicates that the lighting is being upgraded to a more efficient technology. The 'CO₂' icon at the end of the path is smaller than in the baseline scenario, indicating a reduction in emissions.</p>

AMS-II.M. Demand-side energy efficiency activities for installation of low-flow hot water savings devices



<p>Typical project(s)</p>	<p>Activities for direct installation of low-flow hot water savings devices used in residential buildings e.g. low-flow showerheads, kitchen faucets and bathroom faucets.</p>
<p>Type of GHG emissions mitigation action</p>	<p>Energy Efficiency.</p> <ul style="list-style-type: none"> Fuel or electricity savings through the installation of low-flow hot water savings devices.
<p>Important conditions under which the methodology is applicable</p>	<ul style="list-style-type: none"> The project devices (PD) must contain integral, non-removable flow restrictions; Only retrofit projects are allowable; One year warranty of the PD; Compliance to applicable standards of the PD; Equivalent level of service (functional comfort and cleaning performance); PD are directly installed and tested to be functional; PD are marked for clear unique identification; Method for collection, destruction and/or recycling of baseline devices; Procedures to eliminate double counting are explained.
<p>Important parameters</p>	<p>At validation:</p> <ul style="list-style-type: none"> Measured flow rate of baseline device (litres/minute). <p>Monitored:</p> <ul style="list-style-type: none"> Measured flow rate of project device (litres/minute); Measured amount of water used by project device (litres); Temperature of hot water (Maximum 40°C); Temperature of cold water (Minimum 10°C); Determine the number of low-flow devices installed and operating.
<p>BASELINE SCENARIO Less efficient hot water devices are used in residential buildings. More water, that requires heating by electricity or fossil fuel, is consumed.</p>	<p>The diagram illustrates the baseline scenario. It starts with 'Fossil fuel' (flame icon) which is converted into 'Grid' (power plug icon). From the 'Grid', energy is split into two paths: one goes to 'Electricity' (lightning bolt icon) and the other goes to 'CO2' (flame icon). The 'Electricity' path then goes to 'Hot water' (gear icon), which is then consumed by a 'Consumer' (person icon). There is also a direct path from 'Fossil fuel' to 'CO2'.</p>
<p>PROJECT SCENARIO Efficient (low-flow) hot water devices replace less efficient hot water devices thus reducing the amount of water that requires heating by electricity or fossil fuel.</p>	<p>The diagram illustrates the project scenario. It follows the same initial steps as the baseline: 'Fossil fuel' to 'Grid' to 'Electricity' to 'Hot water' to 'Consumer'. However, an 'Upgrade' (gear with arrow icon) is applied to the 'Hot water' step, indicating the installation of a more efficient device. This results in a smaller 'Hot water' box and a smaller 'CO2' box, signifying reduced energy consumption and emissions compared to the baseline.</p>

AMS-II.N. Demand-side energy efficiency activities for installation of energy efficient lighting and/or controls in buildings

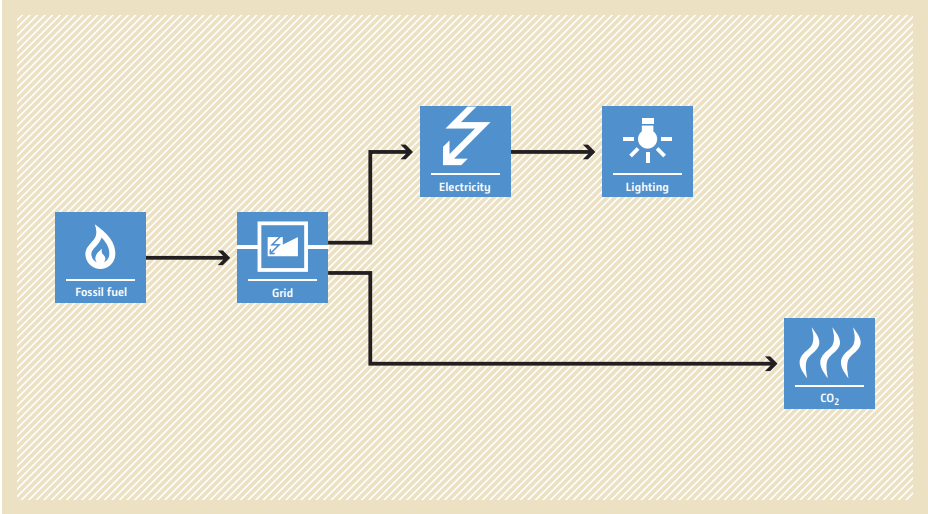
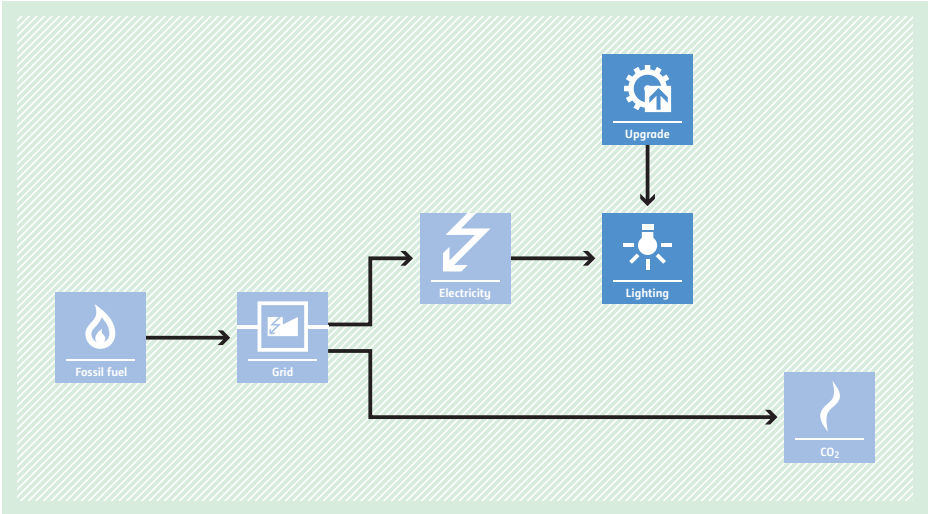
<p>Typical project(s)</p>	<ul style="list-style-type: none"> • Retrofits of existing electric lighting fixtures, lamps, and/or ballasts with more energy-efficient fixtures, lamps, and/or ballasts; • Installation of lighting controls.
<p>Type of GHG emissions mitigation action</p>	<ul style="list-style-type: none"> • Energy efficiency. • Displacement of more-GHG intensive service.
<p>Important conditions under which the methodology is applicable</p>	<ul style="list-style-type: none"> • Only retrofit projects involving direct installation (or delamping) of equipment are allowable; • This methodology is applicable to non-residential and multi-family residential buildings supplied with grid electricity; • Collection, destruction and/or recycling of baseline devices are required.
<p>Important parameters</p>	<p>Monitored:</p> <ul style="list-style-type: none"> • Number, type and wattage of project fixtures/lamps/ballasts/ballast factors and/or control systems installed under the project activity; • Grid emission factor.
<p>BASELINE SCENARIO Electricity is used for inefficient commercial lighting.</p>	 <p>The diagram illustrates the baseline scenario. It starts with a 'Fossil fuel' icon (flame) pointing to a 'Grid' icon (power lines). From the 'Grid', an arrow points to an 'Electricity' icon (lightning bolt), which then points to a 'Lighting' icon (light bulb). A separate arrow from the 'Grid' points directly to a 'CO₂' icon (flame with wavy lines), representing emissions from the grid.</p>
<p>PROJECT SCENARIO Installation of energy efficient lighting and/or controls in commercial buildings.</p>	 <p>The diagram illustrates the project scenario. It follows the same path as the baseline: 'Fossil fuel' to 'Grid' to 'Electricity' to 'Lighting', with a direct arrow from 'Grid' to 'CO₂'. However, an 'Upgrade' icon (gear with upward arrow) is positioned above the 'Lighting' icon, with an arrow pointing down to it, indicating that the lighting is being improved. The 'CO₂' icon in this scenario is smaller than in the baseline, indicating a reduction in emissions.</p>

AMS-II.O. Dissemination of energy efficient household appliances

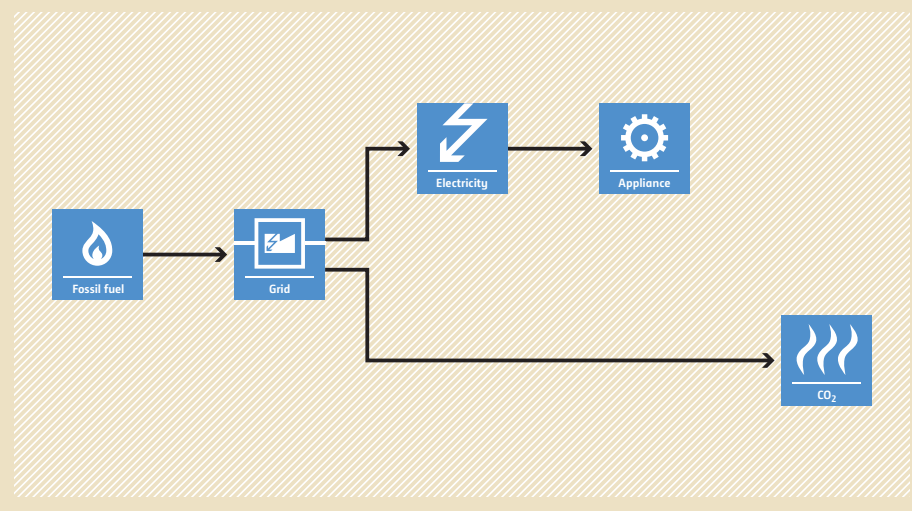
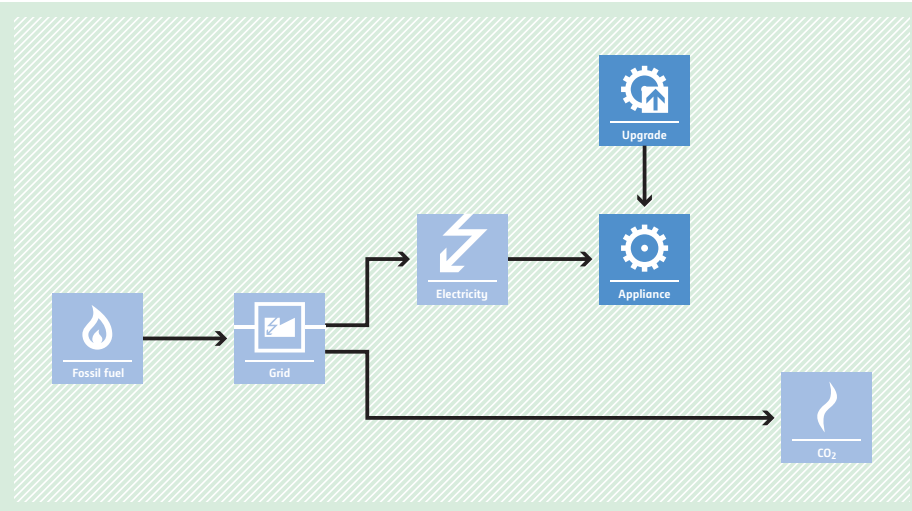
<p>Typical project(s)</p>	<p>Project activities that increase sales dissemination of new household appliances, specifically refrigerating appliances (refrigerators) that have very high efficiencies.</p>
<p>Type of GHG emissions mitigation action</p>	<ul style="list-style-type: none"> • Energy efficiency. • Displacement of more-GHG intensive service.
<p>Important conditions under which the methodology is applicable</p>	<ul style="list-style-type: none"> • Only appliance models utilising refrigerants and foam blowing agents having no ozone depleting potential (ODP) and low global warming potential (GWP <15); • The project refrigerators are designed to run on electricity; • The manufacturers of the project refrigerators are ISO 9001 certified at the time of validation to ensure data reliability.
<p>Important parameters</p>	<ul style="list-style-type: none"> • Number of refrigerators of each model type disseminated, and their serial and model numbers; • Electricity consumption of each refrigerator model disseminated; • Historical sales of the project appliances.
<p>BASELINE SCENARIO Electricity is consumed by inefficient household appliances.</p>	 <p>The diagram illustrates the baseline scenario. It starts with 'Fossil fuel' (represented by a flame icon) which is converted into 'Grid' electricity (represented by a plug icon). From the 'Grid', electricity is distributed to two paths: one leading to 'Electricity' (represented by a lightning bolt icon) which then powers an 'Appliance' (represented by a gear icon), and another path leading directly to 'CO2' emissions (represented by a flame icon). This indicates that the baseline involves inefficient appliances that consume more electricity for the same service, leading to higher CO2 emissions.</p>
<p>PROJECT SCENARIO Installation of energy efficient household appliances in households consuming less electricity.</p>	 <p>The diagram illustrates the project scenario. It follows the same initial steps as the baseline: 'Fossil fuel' is converted to 'Grid' electricity. However, the 'Grid' electricity is now used to power an 'Upgrade' (represented by a gear with an upward arrow icon) which leads to a more efficient 'Appliance' (represented by a gear icon). This efficient appliance consumes less electricity to provide the same service, resulting in a significant reduction in 'CO2' emissions (represented by a flame icon) compared to the baseline scenario.</p>

AMS-II.P. Energy efficient pump-set for agriculture use

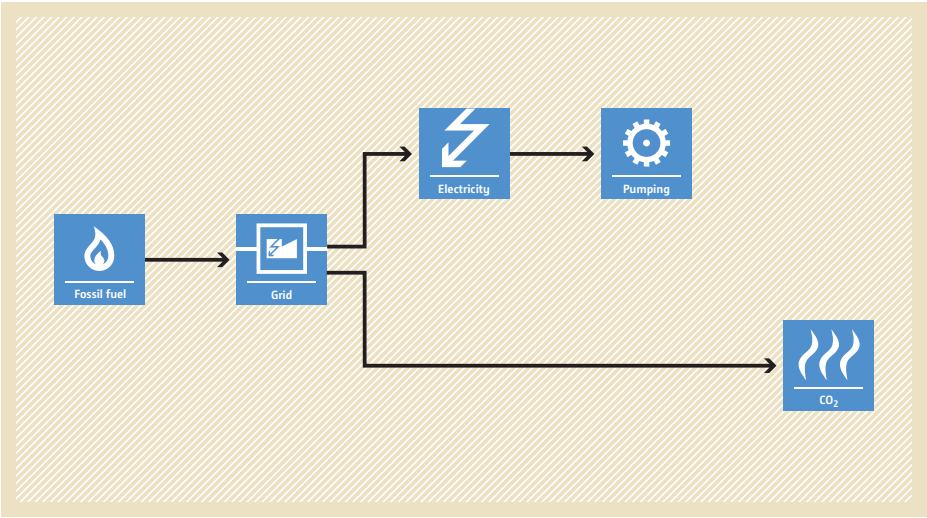
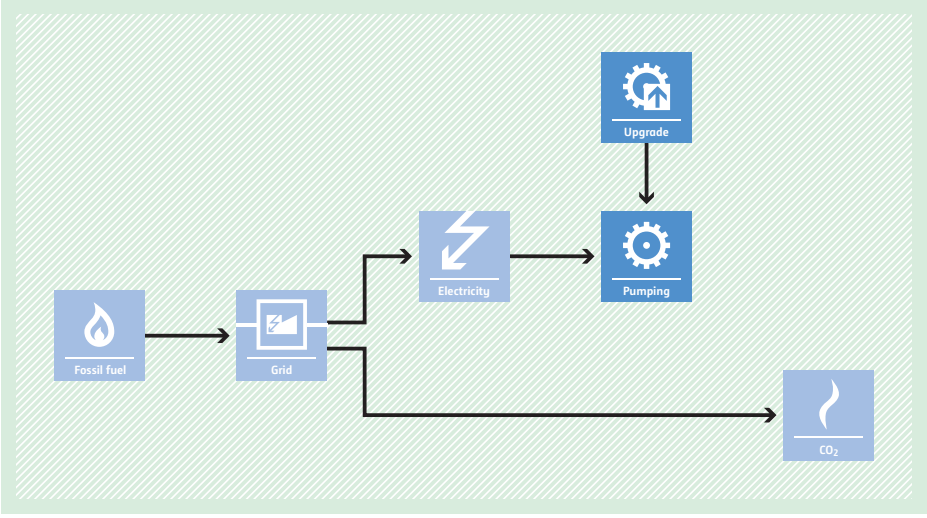
<p>Typical project(s)</p>	<p>Project activities that adopt energy efficient pump-sets that run on grid electricity at one or more agricultural sites.</p>
<p>Type of GHG emissions mitigation action</p>	<ul style="list-style-type: none"> • Energy efficiency <p>Electricity (and fossil fuel) savings through energy efficiency improvement.</p>
<p>Important conditions under which the methodology is applicable</p>	<ul style="list-style-type: none"> • The project pump-set efficiency shall be higher than the baseline pump-set for the whole range of operating conditions; • The methodology is not applicable for retrofitting pump-sets (e.g. replacement of impellers); • Water output corresponding to the initial head shall be higher or at least equal to that of the baseline pump-set water output at the initial head.
<p>Important parameters</p>	<p>At validation:</p> <ul style="list-style-type: none"> • Water flow rate and head of replaced pump-sets; • Performance curves of replaced pump-sets. <p>Monitored:</p> <ul style="list-style-type: none"> • Number of pump-sets installed and remain operating; • Performance curves of project pump-sets; • Operating hours of project pump-sets.
<p>BASELINE SCENARIO Inefficient pump-sets are used for agricultural irrigation.</p>	 <p>The diagram illustrates the baseline scenario. It starts with a 'Fossil fuel' icon (flame) pointing to a 'Grid' icon (power lines). From the 'Grid', an arrow points to an 'Electricity' icon (lightning bolt), which then points to a 'Pumping' icon (gear). A separate arrow from the 'Grid' points directly to a 'CO₂' icon (flame with wavy lines), representing emissions from the grid.</p>
<p>PROJECT SCENARIO Introduction of efficient pump-set for agricultural irrigation.</p>	 <p>The diagram illustrates the project scenario. It starts with a 'Fossil fuel' icon (flame) pointing to a 'Grid' icon (power lines). From the 'Grid', an arrow points to an 'Electricity' icon (lightning bolt), which then points to an 'Upgrade' icon (gear with an upward arrow). From the 'Upgrade' icon, an arrow points to a 'Pumping' icon (gear). A separate arrow from the 'Grid' points directly to a 'CO₂' icon (flame with wavy lines), representing emissions from the grid. The 'Upgrade' step is shown to result in a more efficient pumping process.</p>

AMS-II.Q. Energy efficiency and/or energy supply projects in commercial buildings

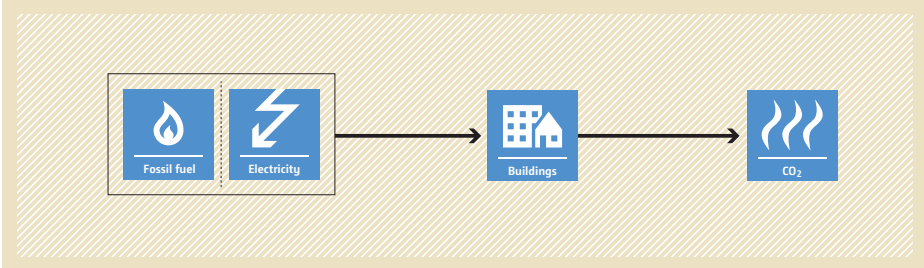
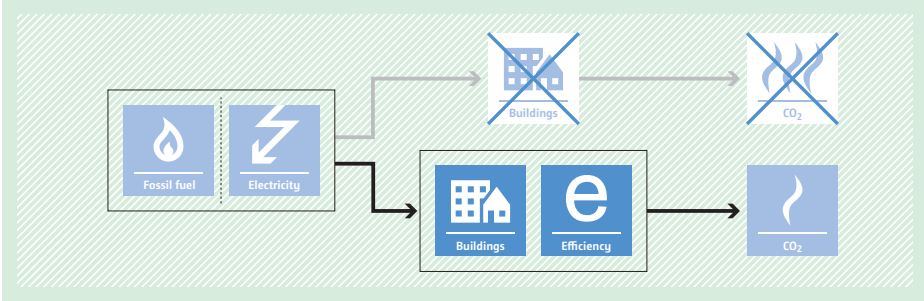
<p>Typical project(s)</p>	<p>On-site building energy supply and whole building energy efficiency projects whose associated emission reductions can be determined with a whole building computerized simulation tool.</p>
<p>Type of GHG emissions mitigation action</p>	<ul style="list-style-type: none"> • Energy efficiency <p>Electricity (and fossil fuel) savings through energy efficiency improvement.</p>
<p>Important conditions under which the methodology is applicable</p>	<ul style="list-style-type: none"> • The methodology is applicable to commercial buildings only (retrofit or new construction); • This methodology is not applicable to project activities that affect off-site district heating and/or cooling plants and distribution networks; • If the energy efficient equipment contains refrigerants, then the refrigerant used in the project case shall have no Ozone Depleting Potential (ODP); • All technologies (e.g. equipment or appliances) used in the project activity shall be new and not transferred from another project activity.
<p>Important parameters</p>	<p>At validation:</p> <ul style="list-style-type: none"> • Ex ante baseline building data; • Historical energy consumption (in case of retrofits); • Information documenting the calibration process. <hr/> <p>Monitored:</p> <ul style="list-style-type: none"> • Weather data; • Energy consumption of the project building(s) on at least a monthly basis; • Base building setting changes and occupancy or tenancy-related setting change.
<p>BASELINE SCENARIO Inefficient building construction and operation.</p>	 <p>The diagram shows a flow from two input boxes labeled 'Fossil fuel' (with a flame icon) and 'Electricity' (with a lightning bolt icon) to a central box labeled 'Buildings' (with a building icon). An arrow then points from the 'Buildings' box to a final box labeled 'CO₂' (with a flame icon).</p>
<p>PROJECT SCENARIO On-site building energy supply and/or whole building energy efficiency measures are reducing consumption of electricity and/or fuel.</p>	 <p>The diagram shows a flow from two input boxes labeled 'Fossil fuel' (with a flame icon) and 'Electricity' (with a lightning bolt icon) to two parallel paths. The top path goes to a crossed-out 'Buildings' box, and the bottom path goes to a box labeled 'Buildings' and 'Efficiency' (with a lowercase 'e' icon). An arrow then points from the 'Buildings' and 'Efficiency' box to a final box labeled 'CO₂' (with a flame icon). The 'CO₂' box in this scenario is smaller than in the baseline scenario, indicating reduced emissions.</p>

AMS-II.R. Energy efficiency space heating measures for residential buildings



<p>Typical project(s)</p>	<p>Energy efficiency and fuel switching measures implemented within residential buildings to improve the space heating, for example: improving building insulation, enhancing glazing of windows, improving efficiency of heating equipment.</p>
<p>Type of GHG emissions mitigation action</p>	<ul style="list-style-type: none"> • Energy efficiency; • Fuel switch. <p>Reduction of fossil fuel use and corresponding emissions through energy efficiency improvements.</p>
<p>Important conditions under which the methodology is applicable</p>	<ul style="list-style-type: none"> • This methodology is applicable to fuel-switching only when it results from the implementation of the energy efficiency measures; • Technology/measures implemented in existing residential buildings; • The impact of the measures implemented by the project activity can be clearly distinguished from changes in energy use due to other variables not influenced by the project activity.
<p>Important parameters</p>	<p>At validation:</p> <ul style="list-style-type: none"> • Fuel consumption before implementation of project; • Conditions for suppressed demand if applicable. <hr/> <p>Monitored:</p> <ul style="list-style-type: none"> • Specifications of the equipment replaced or retrofitted; • Energy use in the buildings after the project implementation; • Fuel consumption.
<p>BASELINE SCENARIO Inefficient heating in residential buildings.</p>	<p>The diagram shows a linear flow from 'Fossil fuel' (represented by a flame icon) to 'Buildings' (represented by a house icon), and finally to 'CO₂' (represented by wavy lines). This is set against a light orange background with a diagonal hatching pattern.</p>
<p>PROJECT SCENARIO Use of more-efficient and/or less-carbon-intensive equipment in buildings.</p>	<p>The diagram shows a flow from 'Fossil fuel' (flame icon) to 'Buildings' (house icon), and then to 'CO₂' (wavy lines). Above the 'Buildings' box is an 'Upgrade' box (gear icon) with a downward arrow pointing to the 'Buildings' box. This is set against a light green background with a diagonal hatching pattern.</p>

AMS-III.A. Offsetting of synthetic nitrogen fertilizers by inoculant application in legumes-grass rotations on acidic soils on existing cropland

<p>Typical project(s)</p>	<p>Application of inoculant on legumes in a legumes-grass rotation cropping on acidic soils on existing cropland substitutes and reduces the production and use of synthetic nitrogen fertilizer use.</p>
<p>Type of GHG emissions mitigation action</p>	<ul style="list-style-type: none"> • GHG emission avoidance. <p>Application of inoculant displaces more-GHG-intensive production of synthetic nitrogen fertilizers.</p>
<p>Important conditions under which the methodology is applicable</p>	<ul style="list-style-type: none"> • The farmers participating have grown legumes and grass in a legumes-grass rotation in the previous three complete rotations without using any inoculant as a fertilizer for legumes, but have used synthetic nitrogen fertilizer for fertilizing legumes; • Only the legume-rhizobia bacteria (inoculant) combinations specified in the methodology are eligible; • For each farmer taking part in the project, reliable and verifiable data on the amount of synthetic nitrogen fertilizer used, separately for each crop type, in the previous three complete rotations of legumes and grass cropping, shall be available; • No change in the types of crop cultivated takes place. In both the baseline and project situation legumes and grass are cultivated in rotations. No other changes in farming practices affecting fertilizer application, except the change in application of inoculant and synthetic nitrogen fertilizer, are taking place during the crediting period.
<p>Important parameters</p>	<p>Monitored:</p> <ul style="list-style-type: none"> • Hectare of crop planted; • Quantity of inoculant (number of rhizobia bacteria), urea and other fertilizers applied (chemical fertilizers as well as organic fertilizers); • Crop yield per crop per hectare; • Independent third party field visits are also required at different stages (e.g. at planting, right before overing etc.).
<p>BASELINE SCENARIO Production and use of synthetic nitrogen fertilizer results in GHG emissions.</p>	
<p>PROJECT SCENARIO Use of legume-rhizobia bacteria (inoculant) substitutes/reduces the use of synthetic nitrogen fertilizer reducing GHG emissions in the fertilizer production process.</p>	

AMS-III.B. Switching fossil fuels

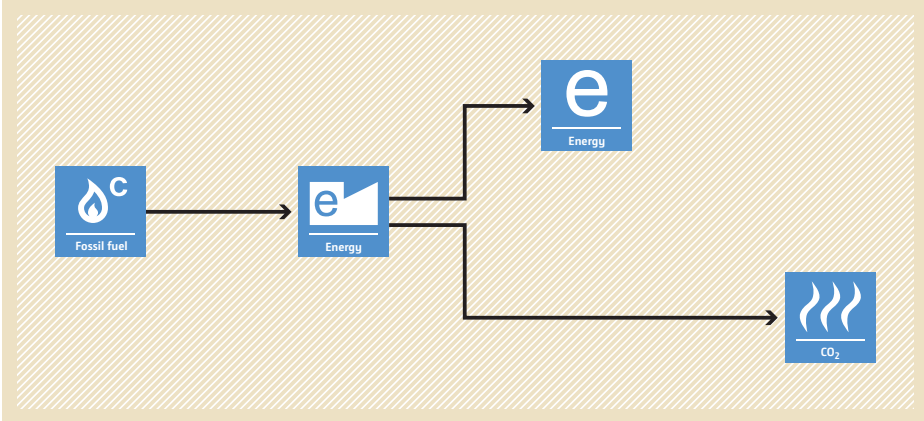
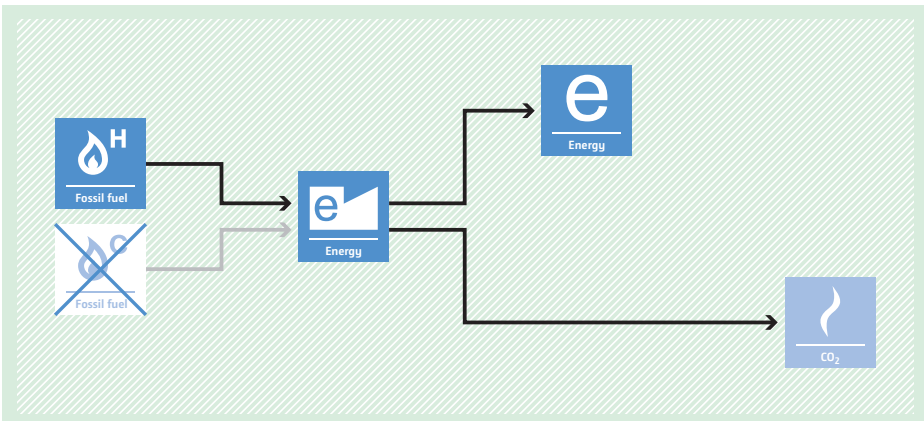
<p>Typical project(s)</p>	<p>The fossil fuel switching in new or existing industrial, residential, commercial, institutional or electricity generation applications.</p>
<p>Type of GHG emissions mitigation action</p>	<ul style="list-style-type: none"> • Fuel switch. <p>Switch to fuel with a lower GHG intensity (in greenfield or retrofit or replacement activities).</p>
<p>Important conditions under which the methodology is applicable</p>	<ul style="list-style-type: none"> • Switch of fossil fuel used in a process with a single output (e.g. electricity, steam or heat); • Project is limited to fuel switching measures which require capital investments; • Projects including biomass or waste gas/energy are not eligible; • Switch of fossil fuel in facilities connected to an isolated grid (s) system is eligible; • Only energy efficiency increase related to the fuel switch is eligible; • Only retrofitting and replacements without integrated process change are eligible; • For project activities where the estimated annual emission reductions of each element process are more than 600 tCO₂e per year the energy use/output should be directly measured, otherwise it is not required.
<p>Important parameters</p>	<p>At validation:</p> <ul style="list-style-type: none"> • Baseline emission factor; • Historical net energy output where the estimated annual emission reductions of each of the element processes are more than 600 tCO₂e. <hr/> <p>Monitored:</p> <ul style="list-style-type: none"> • Quantity of fossil fuel use; • Net energy output where the estimated annual emission reductions of each element process is more than 600 tCO₂e • Output of element process for electricity/thermal energy exported to other facilities shall be monitored at the recipient end.
<p>BASELINE SCENARIO Continuation of the current practice, i.e. use of more-carbon-intensive fossil fuel for energy generation equipment.</p>	 <p>The diagram illustrates the baseline scenario. It starts with a box labeled 'Fossil fuel' with a flame icon and a 'C' superscript. An arrow points to a box labeled 'Energy' with a flame icon and an 'e' superscript. From this 'Energy' box, two arrows branch out: one points to a box labeled 'Energy' with a flame icon and an 'e' superscript, and the other points to a box labeled 'CO₂' with a flame icon.</p>
<p>PROJECT SCENARIO Switch of fuel to less-carbon-intensive fossil fuel in energy generation equipment.</p>	 <p>The diagram illustrates the project scenario. It shows two 'Fossil fuel' boxes on the left. The top one has a flame icon and an 'H' superscript. The bottom one has a flame icon and a 'C' superscript, with a large 'X' over it. An arrow from the 'H' box and a greyed-out arrow from the 'C' box both point to a central 'Energy' box (flame icon, 'e' superscript). From this 'Energy' box, two arrows branch out: one points to an 'Energy' box (flame icon, 'e' superscript) and the other points to a 'CO₂' box (flame icon).</p>

AMS-III.C. Emission reductions by electric and hybrid vehicles

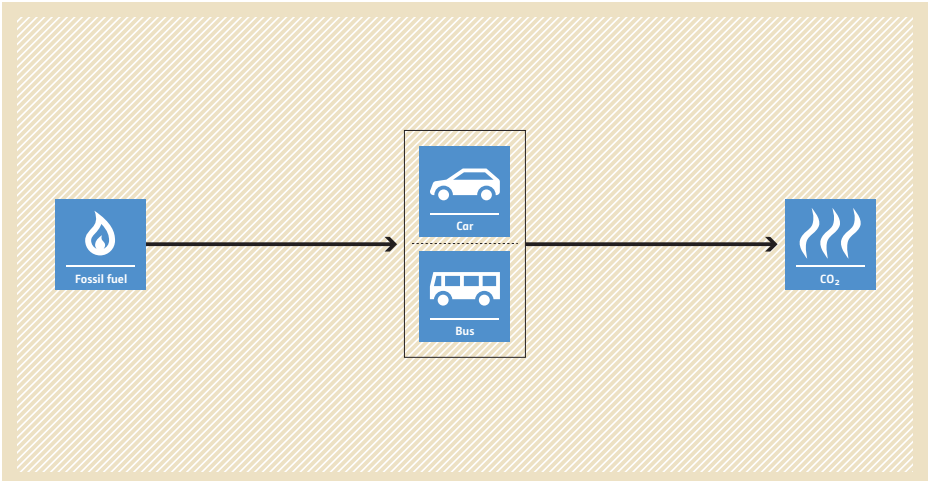
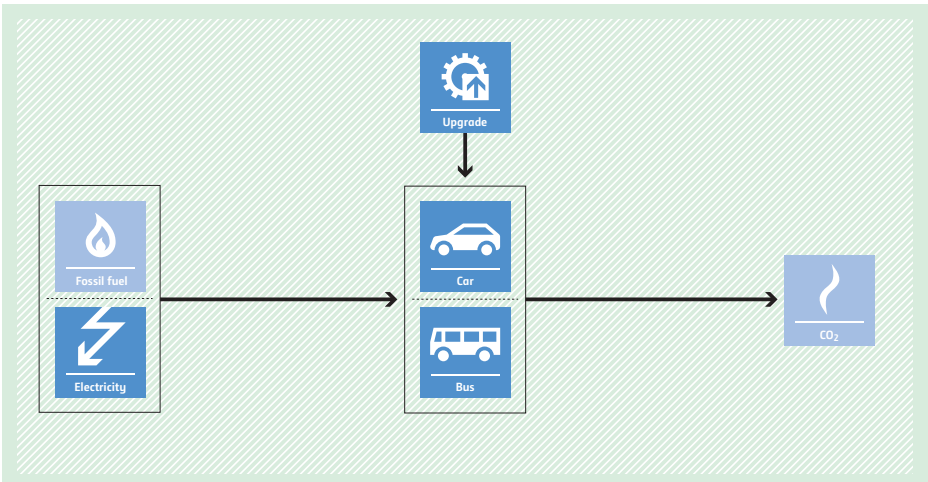
Typical project(s)	Operation of electric and hybrid vehicles for providing transportation services.
Type of GHG emissions mitigation action	<ul style="list-style-type: none"> Fuel switch. Displacement of more-GHG-intensive vehicles.
Important conditions under which the methodology is applicable	<ul style="list-style-type: none"> Project and baseline vehicles should belong to the same vehicle category. Vehicles under a category have comparable passenger/load capacity and power rating with variation of no more than +/-20%; The prevailing regulations pertaining to battery use and disposal shall be complied with.
Important parameters	<p>At validation:</p> <ul style="list-style-type: none"> If applicable: grid emission factor (can also be monitored ex post). <hr/> <p>Monitored:</p> <ul style="list-style-type: none"> Number of electric/hybrid vehicles operated under the project; Quantity of fossil fuel used e.g. for hybrid vehicles and electricity consumption for all electric and hybrid vehicles to determine specific electricity/fossil fuel consumption per km; Annual average distance driven by project vehicles.
BASELINE SCENARIO Operation of more-GHG-emitting vehicles for providing transportation services.	
PROJECT SCENARIO Operation of less-GHG-emitting vehicles with electric/hybrid engines for providing transportation services.	

AMS-III.D. Methane recovery in animal manure management systems

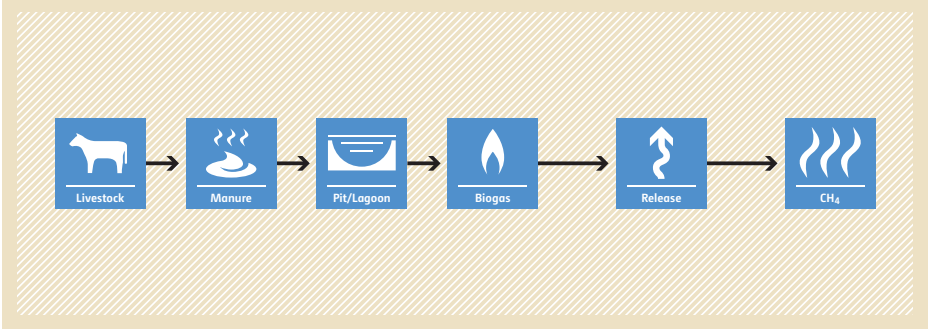
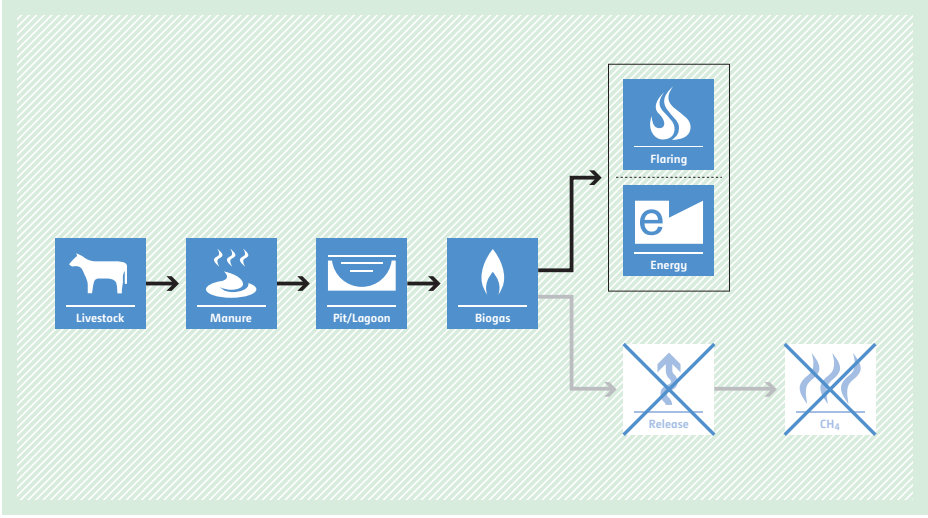
<p>Typical project(s)</p>	<p>Replacement or modification of existing anaerobic manure management systems in livestock farms, or treatment of manure collected from several farms in a centralized plant to achieve methane recovery and destruction by flaring/combustion or energetic use of the recovered methane.</p>
<p>Type of GHG emissions mitigation action</p>	<ul style="list-style-type: none"> • GHG destruction. <p>GHG destruction and displacement of more-GHG-intensive service.</p>
<p>Important conditions under which the methodology is applicable</p>	<ul style="list-style-type: none"> • Manure or the streams obtained after treatment are not discharged into natural water resources (e.g. river or estuaries); • In the baseline scenario the retention time of manure waste in the anaerobic treatment system is greater than one month, and in case of anaerobic lagoons in the baseline, their depths are at least 1 m; • Final sludge must be handled aerobically; • The storage time of the manure after removal from the animal barns, including transportation, should not exceed 45 days before being fed into the anaerobic digester, unless it can be demonstrated that the dry matter content of the manure when removed from the animal barns is more than 20%.
<p>Important parameters</p>	<p>Monitored:</p> <ul style="list-style-type: none"> • Amount of biogas recovered and fuelled, flared or used gainfully; • The annual amount of fossil fuel or electricity used to operate the facility or auxiliary equipment; • Fraction of the manure handled in the manure management system; • Proper soil application (not resulting in methane emissions) of the final sludge must be monitored.
<p>BASELINE SCENARIO Animal manure is left to decay anaerobically and methane is emitted into the atmosphere.</p>	 <pre> graph LR Livestock --> Manure Manure --> PitLagoon[Pit/Lagoon] PitLagoon --> Biogas Biogas --> Release Release --> CH4 </pre>
<p>PROJECT SCENARIO Methane is recovered and destroyed or gainfully used due to replacement or modification of existing anaerobic manure management systems.</p>	 <pre> graph LR Livestock --> Manure Manure --> PitLagoon[Pit/Lagoon] PitLagoon --> Biogas Biogas --> Flaring Biogas --> Release Flaring --> Energy Release --> CH4 Release --- X1[] CH4 --- X2[] style X1 stroke-width:4px, stroke:red style X2 stroke-width:4px, stroke:red </pre>

AMS-III.E. Avoidance of methane production from decay of biomass through controlled combustion, gasification or mechanical/thermal treatment

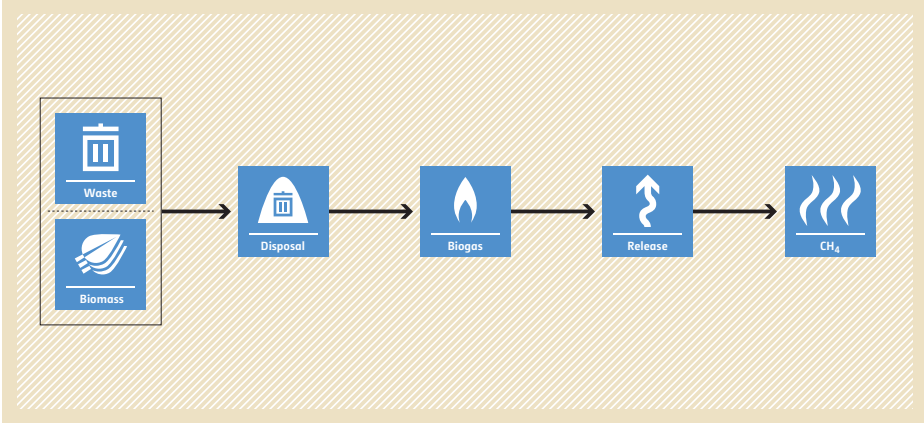
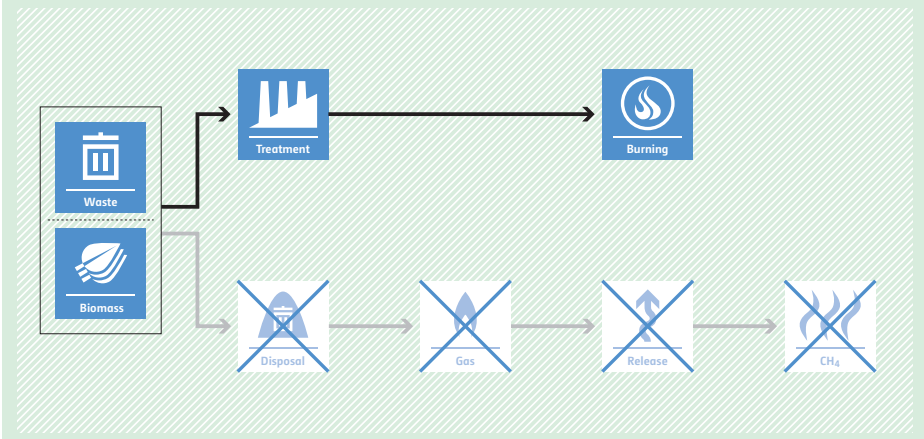
<p>Typical project(s)</p>	<p>Decay of the wastes that would have been left to decay or are already deposited in a waste disposal site is prevented through controlled combustion; or gasification to produce syngas/producer gas; or mechanical/thermal treatment to produce refuse-derived fuel (RDF) or stabilized biomass (SB).</p>
<p>Type of GHG emissions mitigation action</p>	<ul style="list-style-type: none"> • GHG emission avoidance; <p>Avoidance of methane emissions due to prevention of anaerobic decay of biomass in waste. Use of biomass in waste as energy source.</p>
<p>Important conditions under which the methodology is applicable</p>	<ul style="list-style-type: none"> • The produced RDF/SB shall be used for combustion either onsite or off-site; • In case of RDF/SB production, no GHG emissions occur other than biogenic CO₂, due to chemical reactions during the thermal treatment process for example limiting the temperature of thermal treatment to prevent the occurrence of pyrolysis and/or the stack gas analysis; • In case of gasification, all syngas produced shall be combusted and not released unburned into the atmosphere; • During the mechanical/thermal treatment to produce RDF/SB no chemical or other additives shall be used.
<p>Important parameters</p>	<p>Monitored:</p> <ul style="list-style-type: none"> • Amount of waste combusted, gasified or mechanically/thermally treated by the project, as well as its composition through representative sampling; • Quantity of auxiliary fuel used and the non-biomass carbon content of the waste or RDF/SB combusted; • Electricity consumption and/or generation.
<p>BASELINE SCENARIO Organic waste is left to decay and methane is emitted into the atmosphere.</p>	 <p>The baseline scenario flowchart shows a process starting with 'Waste' and 'Biomass' (represented by icons in a box). An arrow points to 'Disposal' (trash can icon), which leads to 'Biogas' (flame icon), then to 'Release' (upward arrow icon), and finally to 'CH₄' (flame icon).</p>
<p>PROJECT SCENARIO Methane emissions will be avoided through controlled combustion, gasification or mechanical/thermal treatment of the wastes. In case of energetic use of organic waste, displacement of more-GHG-intensive energy generation.</p>	 <p>The project scenario flowchart shows 'Waste' and 'Biomass' (in a box) leading to 'Treatment' (factory icon), which then leads to 'Burning' (flame in a circle icon). Below this, the baseline steps 'Disposal', 'Gas', 'Release', and 'CH₄' are shown but are crossed out with large 'X' marks, indicating they are avoided in the project scenario.</p>

AMS-III.F. Avoidance of methane emissions through composting

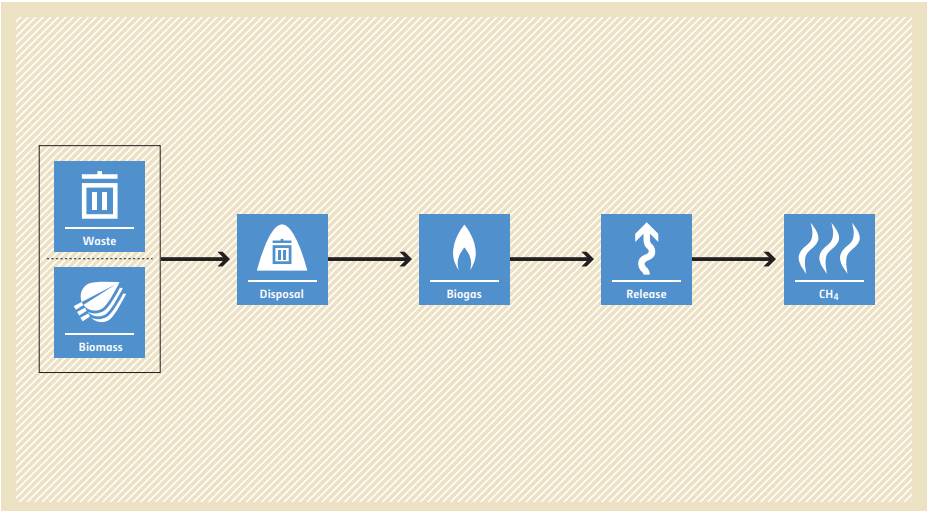
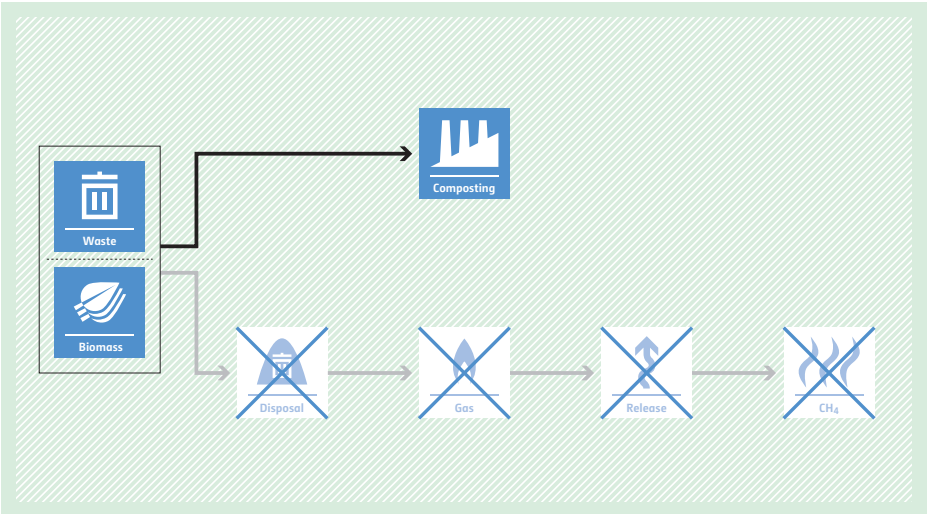

<p>Typical project(s)</p>	<p>Controlled biological treatment of biomass or other organic matter is introduced through aerobic treatment by composting and proper soil application of the compost.</p>
<p>Type of GHG emissions mitigation action</p>	<ul style="list-style-type: none"> • GHG emission avoidance. <p>Avoidance of GHG emissions by alternative treatment process.</p>
<p>Important conditions under which the methodology is applicable</p>	<ul style="list-style-type: none"> • Recovery and combustion of landfill gas is not eligible; • Identified landfill(s) should be able to accommodate the waste to be used for the project for the duration of the crediting period; or it is common practice in the region to dispose of the waste in solid waste disposal sites (landfills).
<p>Important parameters</p>	<p>Monitored:</p> <ul style="list-style-type: none"> • Quantity of waste biologically treated and its composition through representative sampling; • When project includes co-treating of wastewater, the volume of co-treated wastewater and its COD content through representative sampling; • Annual amount of fossil fuel or electricity used to operate the facilities or auxiliary equipment.
<p>BASELINE SCENARIO Biomass and other organic matter (including manure where applicable) are left to decay and methane is emitted into the atmosphere.</p>	 <p>The baseline scenario flowchart shows a sequence of steps: 1. Waste and Biomass (represented by icons in a box) lead to 2. Disposal (landfill icon), which produces 3. Biogas (flame icon), which is then 4. Released (upward arrow icon), resulting in 5. CH₄ emissions (flame icon).</p>
<p>PROJECT SCENARIO Methane emissions are avoided through composting.</p>	 <p>The project scenario flowchart shows a diversion from the baseline. Waste and Biomass (in a box) are sent to 1. Composting (factory icon). Simultaneously, the baseline steps are shown but crossed out with blue 'X' marks: 2. Disposal, 3. Gas (flame icon), 4. Release, and 5. CH₄ emissions.</p>



AMS-III.G. Landfill methane recovery

<p>Typical project(s)</p>	<p>Capture and combustion of methane from landfills used for disposal of residues from human activities including municipal, industrial and other solid wastes containing biodegradable organic matter.</p>
<p>Type of GHG emissions mitigation action</p>	<ul style="list-style-type: none"> • GHG destruction. <p>Destruction of methane and displacement of more-GHG-intensive energy generation.</p>
<p>Important conditions under which the methodology is applicable</p>	<ul style="list-style-type: none"> • The project activity does not reduce the amount of organic waste that would have been recycled in its absence; • The management of the solid waste disposal site in the project activity shall not be changed deliberately to increase methane generation compared to the situation prior to the implementation of the project activity; • Baseline emissions shall exclude methane emissions that would have to be removed to comply with national or local safety requirement or legal regulations; • The effect of methane oxidation that is present in the baseline and absent in the project activity shall be taken into account.
<p>Important parameters</p>	<p>Monitored:</p> <ul style="list-style-type: none"> • The amount of methane recovered and gainfully used, fuelled or flared shall be monitored ex post, using continuous flow meters; • Fraction of methane in the landfill gas; • Flare efficiency; • Electricity generation (only for project activities utilizing the recovered methane for power generation).
<p>BASELINE SCENARIO Biomass and other organic matter in waste are left to decay and methane is emitted into the atmosphere.</p>	<p>The diagram illustrates the baseline scenario. It starts with a box containing 'Waste' (represented by a trash can icon) and 'Biomass' (represented by a leaf icon). An arrow points to a 'Disposal' box (trash can icon). From there, an arrow points to 'Landfill gas' (flame icon). Another arrow points to 'Release' (upward arrow icon), which finally leads to 'CH₄' (flame icon).</p>
<p>PROJECT SCENARIO Methane in the landfill gas is captured and destroyed or used. In case of energetic use of landfill gas, displacement of more-GHG-intensive energy generation.</p>	<p>The diagram illustrates the project scenario. It starts with a box containing 'Waste' (trash can icon) and 'Biomass' (leaf icon). An arrow points to a 'Disposal' box (trash can icon). From there, an arrow points to 'Landfill gas' (flame icon). From 'Landfill gas', two paths emerge: one leads to a box containing 'Flaring' (flame icon) and 'Energy' (e icon), and the other leads to a 'Release' box (upward arrow icon) which is crossed out with a large 'X'. This 'Release' box then points to a 'CH₄' box (flame icon), which is also crossed out with a large 'X'.</p>

AMS-III.H. Methane recovery in wastewater treatment

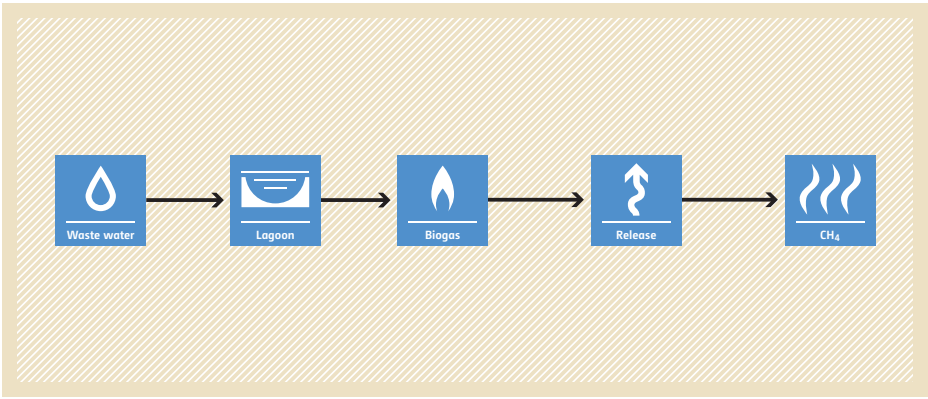
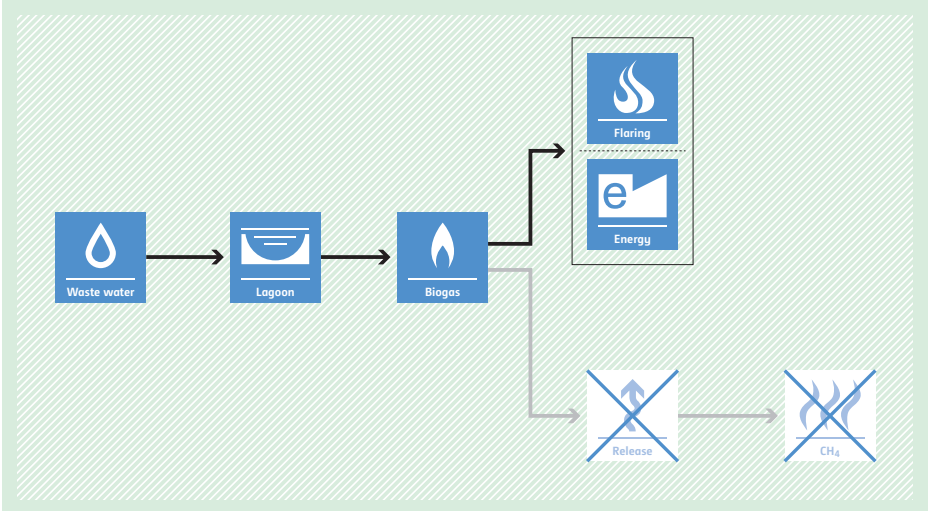
<p>Typical project(s)</p>	<p>Recovery of biogas resulting from anaerobic decay of organic matter in wastewaters through introduction of anaerobic treatment system for wastewater and/or sludge treatment.</p>
<p>Type of GHG emissions mitigation action</p>	<ul style="list-style-type: none"> • GHG destruction. <p>Destruction of methane emissions and displacement of more-GHG-intensive service.</p>
<p>Important conditions under which the methodology is applicable</p>	<ul style="list-style-type: none"> • Anaerobic lagoons should be deeper than 2 metres, without aeration, ambient temperature above 15°C, at least during part of the year, on a monthly average basis. The minimum interval between two consecutive sludge removal events shall be 30 days; • In determining baseline emissions, historical records of at least one year prior to the project implementation shall be available. Otherwise, a representative measurement campaign is required.
<p>Important parameters</p>	<p>At validation:</p> <ul style="list-style-type: none"> • COD removal efficiency of the baseline system. <p>Monitored:</p> <ul style="list-style-type: none"> • Flow of wastewater; • Chemical oxygen demand of the wastewater before and after the treatment system; • Amount of sludge as dry matter in each sludge treatment system; • Amount of biogas recovered, fuelled, flared or utilized (e.g. injected into a natural gas distribution grid or distributed via a dedicated piped network).
<p>BASELINE SCENARIO Methane from the decay of organic matter in wastewater or sludge is being emitted into the atmosphere.</p>	 <p>The baseline scenario flowchart shows a linear process: Waste water (represented by a water drop icon) flows into a Lagoon (represented by a lagoon icon), which produces Biogas (represented by a flame icon). The Biogas is then released (represented by an upward arrow icon) into the atmosphere, where it is converted to CH4 (represented by a flame icon).</p>
<p>PROJECT SCENARIO Methane is recovered and destroyed due to the introduction of new or modification of existing wastewater or sludge treatment system. In case of energetic use of biogas, displacement of more-GHG-intensive energy generation.</p>	 <p>The project scenario flowchart shows the same initial steps as the baseline: Waste water flows into a Lagoon, which produces Biogas. However, the Biogas is then split into two paths. One path leads to a box containing 'Flaring' (flame icon) and 'Energy' (e icon), indicating that the biogas is used for energy generation. The other path leads to a crossed-out 'Release' icon (upward arrow) and a crossed-out 'CH4' icon (flame), indicating that methane emissions are avoided.</p>

AMS-III.I. Avoidance of methane production in wastewater treatment through replacement of anaerobic systems by aerobic systems

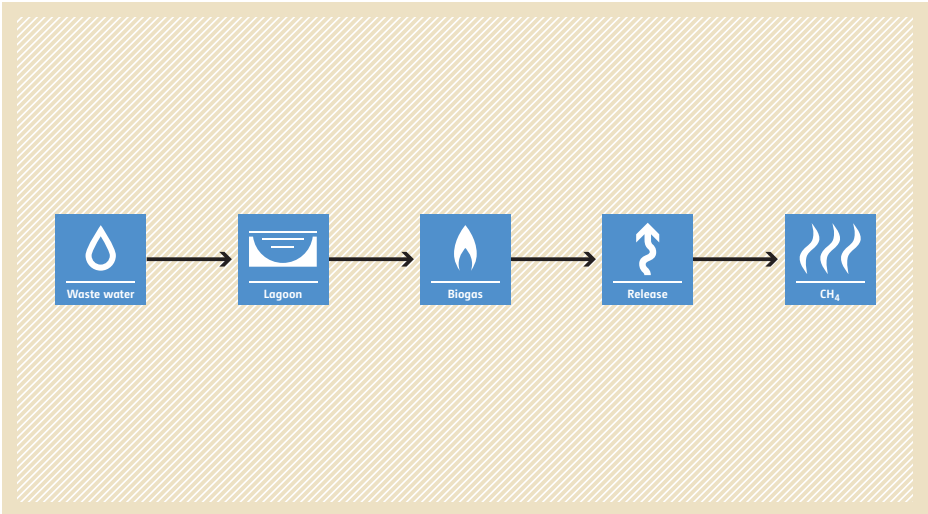
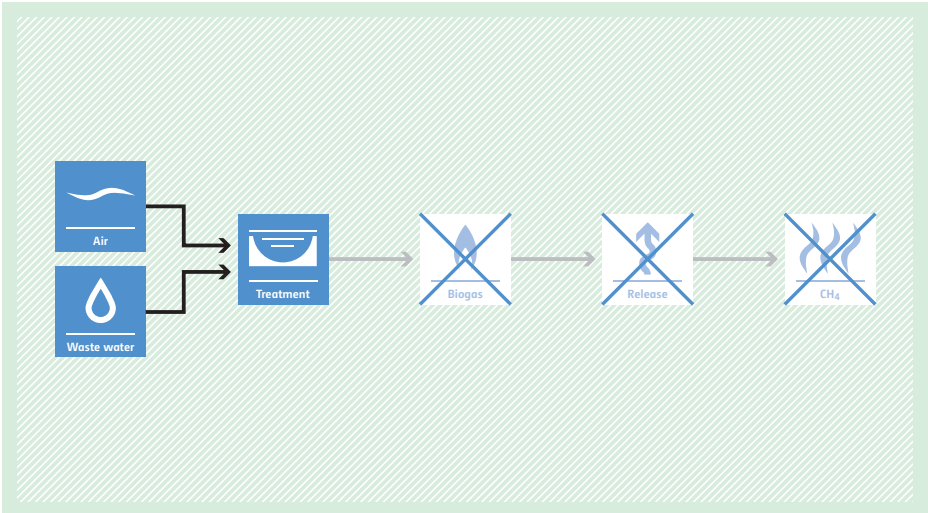
<p>Typical project(s)</p>	<p>Avoidance of production of methane from organic matter in wastewater being treated in anaerobic systems. Due to the project, the anaerobic systems (without methane recovery) are substituted by aerobic biological systems.</p>
<p>Type of GHG emissions mitigation action</p>	<ul style="list-style-type: none"> • GHG emission avoidance. <p>Avoidance of methane emissions from anaerobic decay of organic matter in wastewater.</p>
<p>Important conditions under which the methodology is applicable</p>	<ul style="list-style-type: none"> • In order to determine baseline emissions, at least one year of historical data is required. Otherwise, a 10-day measurement campaign should be carried out.
<p>Important parameters</p>	<p>At validation:</p> <ul style="list-style-type: none"> • COD removal efficiency of the baseline system. <hr/> <p>Monitored:</p> <ul style="list-style-type: none"> • Amount of COD treated in the wastewater treatment plant(s), amount of wastewater entering and/or exiting the project; • Amount of sludge produced and sludge generation ratio; • Amount of fossil fuel and electricity used by the project facilities; • Use of the final sludge will be monitored during the crediting period.
<p>BASILINE SCENARIO Organic matter in wastewaters is being treated in anaerobic systems and produced methane is being released into the atmosphere.</p>	 <p>The diagram illustrates the baseline scenario for wastewater treatment. It starts with 'Waste water' (represented by a water drop icon) entering a 'Lagoon' (represented by a lagoon icon). From the lagoon, 'Biogas' (represented by a flame icon) is produced. This biogas is then 'Released' (represented by an upward arrow icon) into the atmosphere, where it is converted into 'CH₄' (represented by a flame icon with wavy lines).</p>
<p>PROJECT SCENARIO Anaerobic wastewater treatment systems, without methane recovery, are substituted by aerobic treatment systems.</p>	 <p>The diagram illustrates the project scenario. 'Air' (represented by a cloud icon) and 'Waste water' (represented by a water drop icon) enter a 'Treatment' system (represented by a lagoon icon). The 'Biogas' (represented by a flame icon) and 'Release' (represented by an upward arrow icon) stages are crossed out with a large 'X', indicating that these processes are avoided. Consequently, 'CH₄' (represented by a flame icon with wavy lines) is also crossed out, indicating that methane emissions are avoided.</p>

AMS-III.J. Avoidance of fossil fuel combustion for carbon dioxide production to be used as raw material for industrial processes

Typical project(s)	Switch from CO ₂ of fossil origin to a source of CO ₂ from renewable origin.
Type of GHG emissions mitigation action	<ul style="list-style-type: none"> • Feedstock switch. Avoidance of fossil fuel combustion to provide CO ₂ by the use of CO ₂ that is generated from renewable sources.
Important conditions under which the methodology is applicable	<ul style="list-style-type: none"> • CO₂ from combustion of renewable biomass would have been emitted into the atmosphere and not otherwise used; • The generation of CO₂ from fossil or mineral sources in the baseline is only for the purpose of CO₂ production to be used for the production of inorganic compounds; • CO₂ from fossil or mineral sources that is used for the production of inorganic compounds prior to the project will not be emitted into the atmosphere when the project is in place.
Important parameters	At validation: <ul style="list-style-type: none"> • Historical specific fuel consumption per tonne of output. Monitored: <ul style="list-style-type: none"> • Amount of the final product produced on a monthly basis.
BASELINE SCENARIO Fossil fuels are used to produce CO ₂ which is used as raw material; CO ₂ from a renewable source is vented into the atmosphere.	
PROJECT SCENARIO Fossil fuels are no longer used to produce CO ₂ . The CO ₂ stream from renewable sources is used as raw material for a production process.	

AMS-III.K. Avoidance of methane release from charcoal production

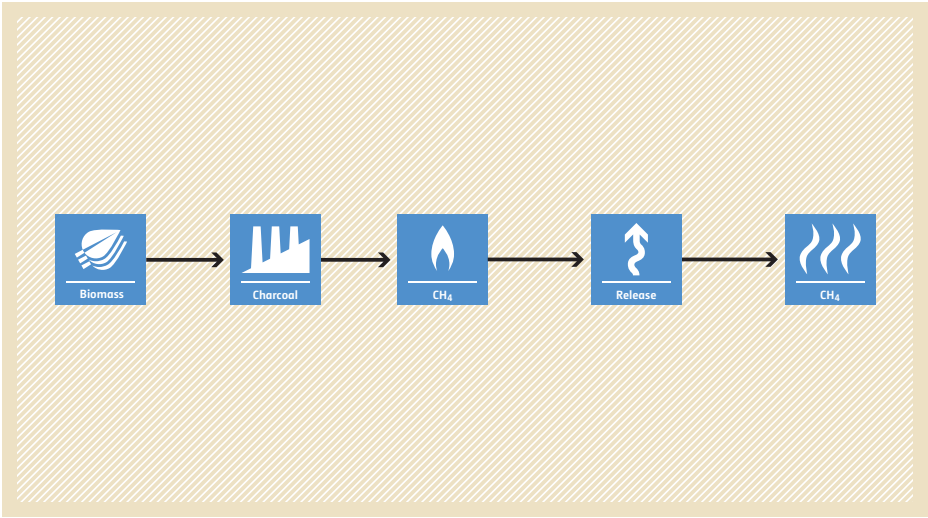
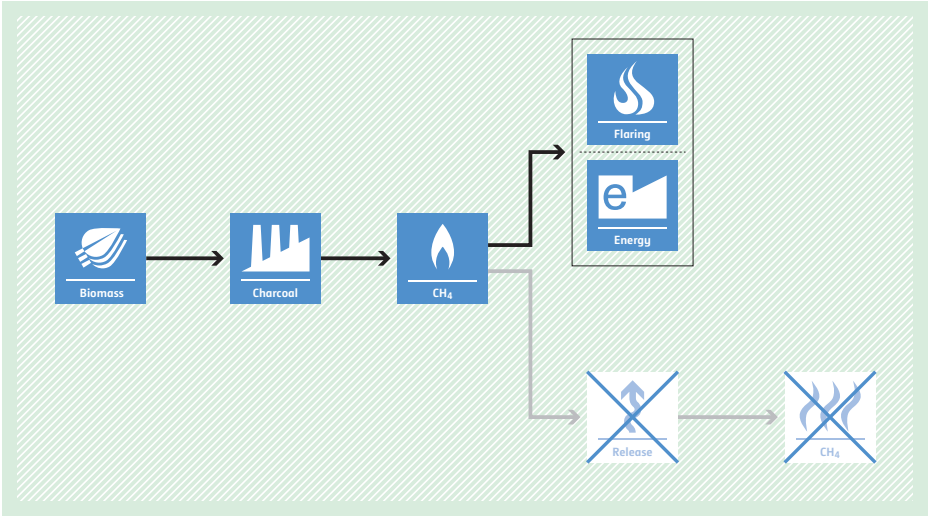
<p>Typical project(s)</p>	<p>Construction of a new charcoal production facility with recovery and flaring/combustion of methane or retrofitting of existing production facilities.</p>
<p>Type of GHG emissions mitigation action</p>	<ul style="list-style-type: none"> • GHG destruction. <p>Use of a technology that destructs or recovers methane generated during the production of charcoal.</p>
<p>Important conditions under which the methodology is applicable</p>	<ul style="list-style-type: none"> • Laws restricting methane emissions from charcoal production either do not exist or are not enforced; • No relevant changes in greenhouse gas emissions other than methane occur as a consequence of the project and/or need to be accounted for; • No changes in the type and source of biomass used for charcoal production.
<p>Important parameters</p>	<p>At validation:</p> <ul style="list-style-type: none"> • Methane emission factor in the baseline. <p>Monitored:</p> <ul style="list-style-type: none"> • Quantity of raw material used and its moisture content; • Quantity of charcoal produced and its moisture content; • Amount of methane generated, fuelled or flared; • Power and auxiliary fuel consumption of the facility.
<p>BASELINE SCENARIO Biomass is transformed into charcoal. Methane is emitted in the process.</p>	 <p>The baseline scenario flowchart shows a linear process: Biomass (represented by a leaf icon) is converted to Charcoal (represented by a factory icon). From Charcoal, CH₄ (represented by a flame icon) is produced. This CH₄ then undergoes Release (represented by an upward arrow icon), resulting in CH₄ emissions (represented by a flame icon).</p>
<p>PROJECT SCENARIO Biomass is transformed into charcoal. Methane is recovered and combusted. In case of energetic use of methane, displacement of more-GHG-intensive energy generation.</p>	 <p>The project scenario flowchart shows the same initial steps as the baseline: Biomass is converted to Charcoal, which produces CH₄. However, the CH₄ is then split into two paths. One path leads to Flaring (represented by a flame icon) and Energy generation (represented by a power plug icon), which is highlighted in a box. The other path leads to Release (represented by an upward arrow icon) and CH₄ emissions (represented by a flame icon). Both the Release and CH₄ emission icons are crossed out with a large 'X', indicating that these emissions are avoided in the project scenario.</p>

AMS-III.L. Avoidance of methane production from biomass decay through controlled pyrolysis

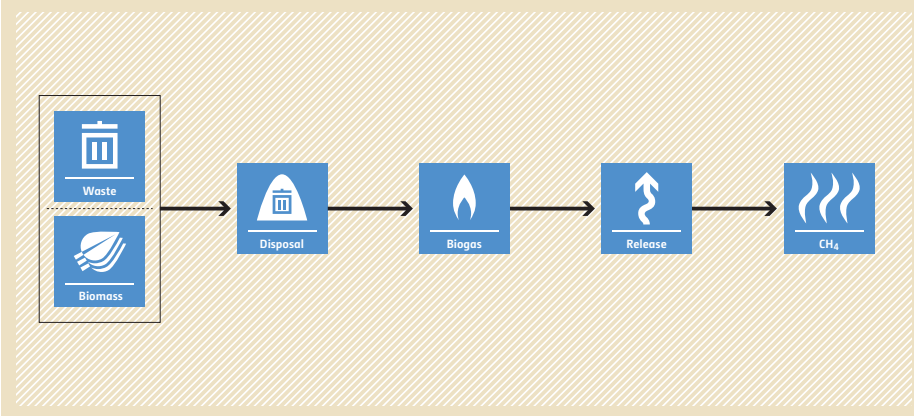
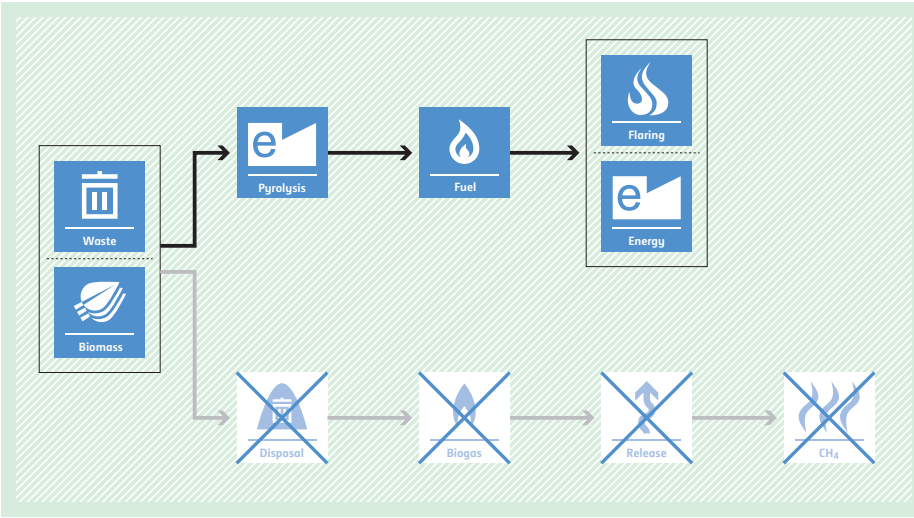
<p>Typical project(s)</p>	<p>Avoidance of the production of methane from organic matter that would have otherwise been left to decay under anaerobic conditions in a solid waste disposal site without methane recovery. Due to the project, decay is prevented through controlled pyrolysis.</p>
<p>Type of GHG emissions mitigation action</p>	<ul style="list-style-type: none"> • GHG emission avoidance. <p>GHG emission avoidance and replacement of more-GHG-intensive service by pyrolysis of organic matter.</p>
<p>Important conditions under which the methodology is applicable</p>	<ul style="list-style-type: none"> • The pyrolysed residues are no longer prone to anaerobic decomposition; • Measures shall include recovery and combustion of non-CO greenhouse gases produced during pyrolysis; • The location and characteristics of the disposal site in the baseline condition shall be known, in such a way as to allow the estimation of its methane emissions.
<p>Important parameters</p>	<p>Monitored:</p> <ul style="list-style-type: none"> • Percentage composition of volatile carbon, fixed carbon, ashes and moisture in the waste processed by pyrolysis (by a representative number of samples); • Amount and composition (weight fraction of each waste type) of waste processed by pyrolysis; • Quantity of non-biogenic waste processed by pyrolysis; • Quantity of auxiliary fuel used and power consumption of the project facilities and/or power generation by the project.
<p>BASELINE SCENARIO Organic matter will decay under clearly anaerobic conditions in a solid waste disposal site and the produced methane is being released into the atmosphere.</p>	 <p>The diagram illustrates the baseline scenario. It starts with a box containing 'Waste' (trash can icon) and 'Biomass' (leaf icon). An arrow points to a 'Disposal' box (trash can in a mound). From there, an arrow points to a 'Biogas' box (flame icon). Another arrow points to a 'Release' box (upward arrow icon). The final arrow points to a 'CH₄' box (flame icon).</p>
<p>PROJECT SCENARIO Methane production due to anaerobic decay of organic matter will be avoided through controlled pyrolysis. In case of energetic use of products (e.g. pyrolysis gas or oil), displacement of more-GHG-intensive energy generation.</p>	 <p>The diagram illustrates the project scenario. It starts with a box containing 'Waste' (trash can icon) and 'Biomass' (leaf icon). Two paths emerge from this box. The top path goes to a 'Pyrolysis' box (flame with 'e' icon), then to a 'Fuel' box (flame icon), and finally to a box containing 'Flaring' (flame icon) and 'Energy' (flame with 'e' icon). The bottom path, representing the baseline, is crossed out with a large 'X' and includes 'Disposal' (trash can in a mound), 'Biogas' (flame icon), 'Release' (upward arrow icon), and 'CH₄' (flame icon).</p>

AMS-III.M. Reduction in consumption of electricity by recovering soda from paper manufacturing process

Typical project(s)	Recovery of caustic soda from waste black liquor generated in paper manufacturing.
Type of GHG emissions mitigation action	<ul style="list-style-type: none"> • GHG emission avoidance. Reduction of production of caustic soda and thereby reduction of electricity consumption by recovery of caustic soda from black liquor.
Important conditions under which the methodology is applicable	<ul style="list-style-type: none"> • Not applicable.
Important parameters	At validation: <ul style="list-style-type: none"> • Historical electricity intensity of soda production (including imports); • Grid emission factor (can also be monitored ex post). Monitored: <ul style="list-style-type: none"> • Quantity of caustic soda recovered per year; • Electricity consumption, consumption of fossil fuel and auxiliary fuel in the caustic soda recovery plant; • Quantity of residues produced, portion of residue used for the production of lime and portion of residue that is disposed in a solid waste disposal site.

BASELINE SCENARIO

Black liquor from paper production is wasted. Much electricity is needed to produce caustic soda that is consumed in the paper mill.

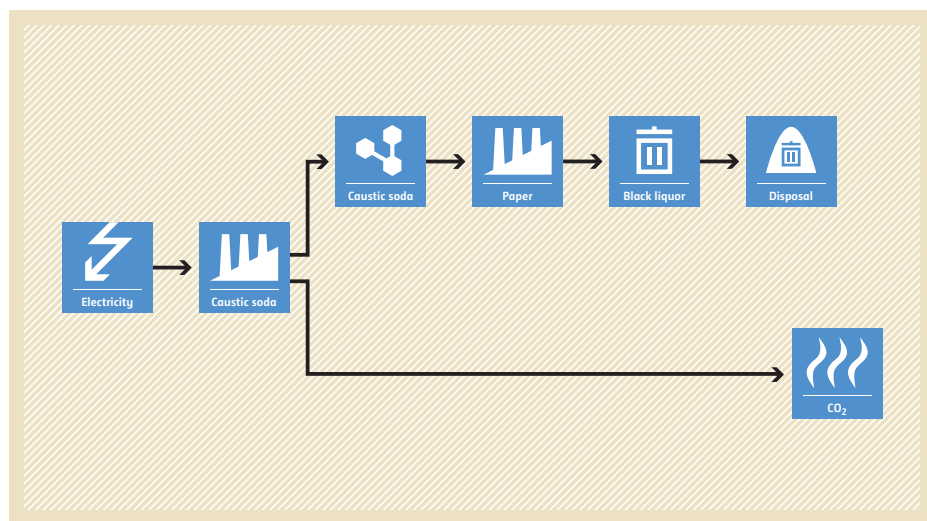

PROJECT SCENARIO

Caustic soda is recovered from black liquor to displace equivalent quantity of purchased caustic soda. Less electricity is required for recovery.

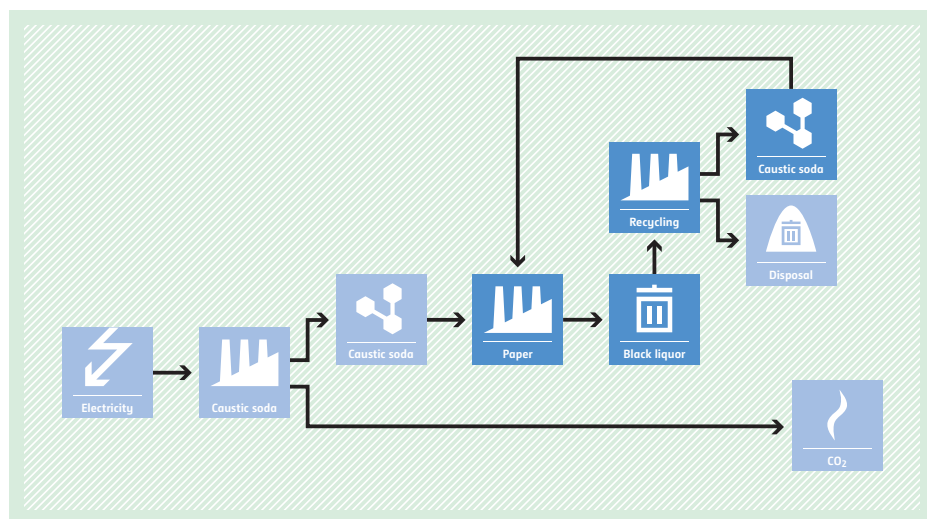

AMS-III.N. Avoidance of HFC emissions in poly urethane foam (PUF) manufacturing

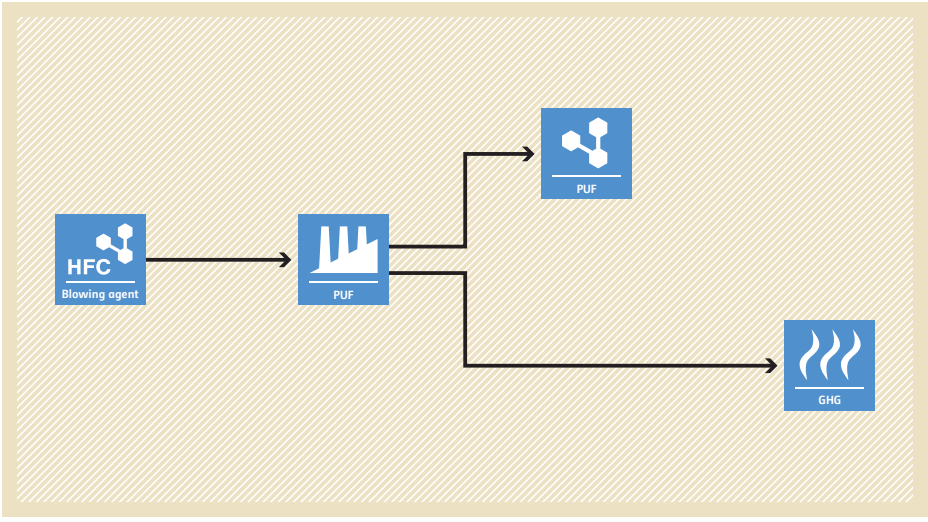
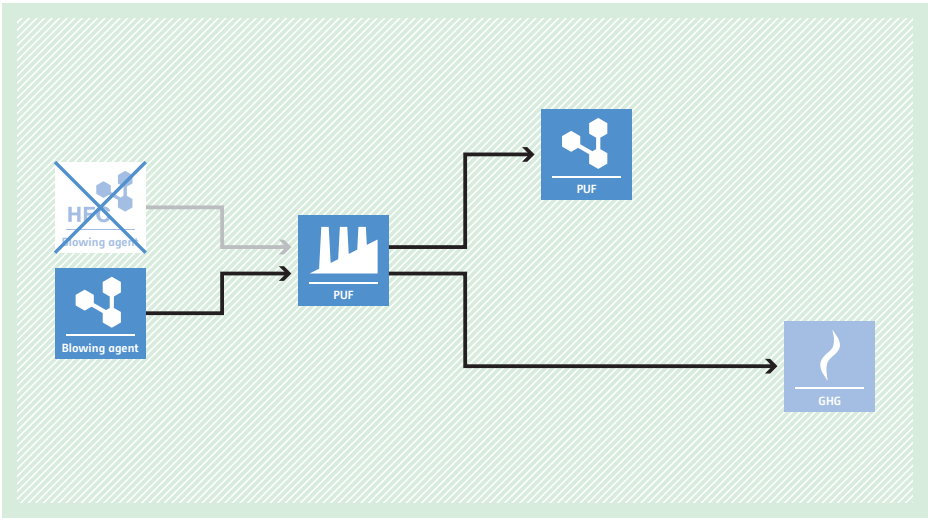
<p>Typical project(s)</p>	<p>Use of a non-GHG blowing agent (e.g. pentane) to replace HFC gases used as a blowing agent (e.g. HFC-134a, HFC-152a, HFC-365mfc and HFC-245fa) during the production of PUF in an existing or a new manufacturing facility.</p>
<p>Type of GHG emissions mitigation action</p>	<ul style="list-style-type: none"> • Feedstock switch. <p>Avoidance of fugitive emissions of HFC gases through the use of a non-GHG blowing agent.</p>
<p>Important conditions under which the methodology is applicable</p>	<ul style="list-style-type: none"> • In case a project is implemented at an existing facility, only HFC blowing agent was used in PUF production for at least three years prior to the project implementation; • There are no local regulations that constrain the use of HFC and hydrocarbon (e.g. pentane) as blowing agents; • PUF produced with a non-GHG blowing agent will have equivalent or superior insulating properties than the PUF produced using a HFC blowing agent; • Emission reductions can be claimed only for domestically sold PUF and excludes export of the manufactured PUF.
<p>Important parameters</p>	<p>At validation:</p> <ul style="list-style-type: none"> • The first year and annual losses of HFC blowing agent. <hr/> <p>Monitored:</p> <ul style="list-style-type: none"> • Total quantity of PUF production (in m) on daily basis.
<p>BASELINE SCENARIO Production of PUF using HFC blowing agents.</p>	
<p>PROJECT SCENARIO Production of PUF using pentane blowing agents.</p>	

AMS-III.O. Hydrogen production using methane extracted from biogas

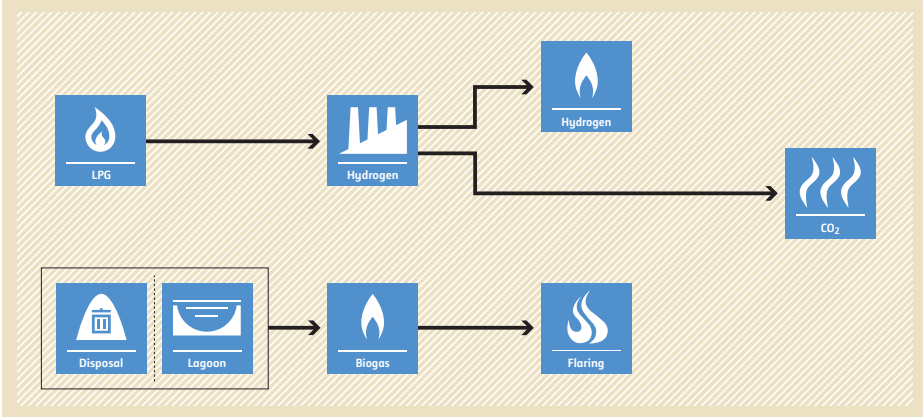
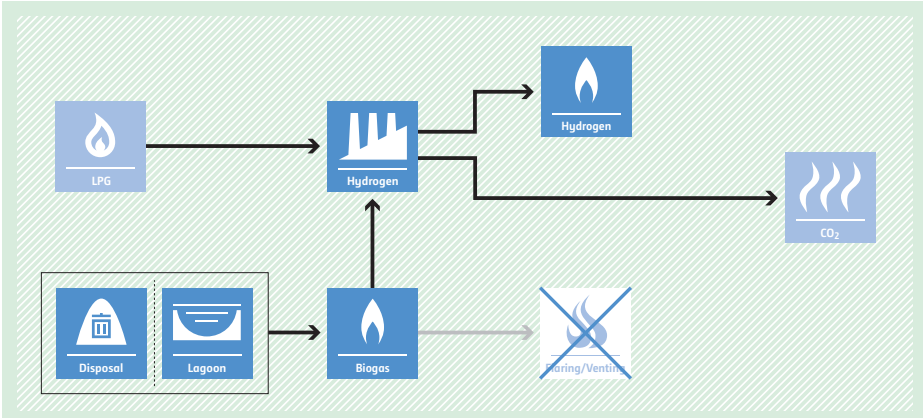
<p>Typical project(s)</p>	<p>Installation of biogas purification system to isolate methane from biogas for the production of hydrogen displacing LPG as both feedstock and fuel in a hydrogen production unit. Examples are the installation of a biogas purification system to isolate methane from biogas which is being flared in the baseline situation or installation of a biogas purification system in combination with installation of new measures that recover methane from organic matter from waste water treatment plants or landfills, using technologies/measures covered in AMS-III.H. or AMS-III.G.</p>
<p>Type of GHG emissions mitigation action</p>	<ul style="list-style-type: none"> Fuel and feedstock switch. <p>Fuel and feed stock switch to reduce consumption of fossil fuel.</p>
<p>Important conditions under which the methodology is applicable</p>	<ul style="list-style-type: none"> This methodology is not applicable to technologies displacing the production of hydrogen from electrolysis; The methodology is only applicable if it can be ensured that there is no diversion of biogas that is already being used for thermal or electrical energy generation or utilized in any other (chemical) process in the baseline.
<p>Important parameters</p>	<p>Monitored:</p> <ul style="list-style-type: none"> Continuous metering of produced hydrogen on volumetric basis; Continuous metering of LPG used as feedstock to hydrogen production unit; Continuous monitoring of specific fuel consumption of LPG when biogas is not available in sufficient quantity; Continuous measurement of electricity and fuel used by the biogas purification system; Continuous measurement of biogas produced by the waste water treatment system, landfill gas capture system or other processes producing biogas.
<p>BASELINE SCENARIO LPG is used as feedstock and fuel for hydrogen production.</p>	 <p>The baseline scenario flowchart shows two parallel processes. The top process starts with an 'LPG' icon (flame) pointing to a 'Hydrogen' icon (factory), which then branches to a 'Hydrogen' icon (flame) and a 'CO2' icon (flames). The bottom process starts with 'Disposal' and 'Lagoon' icons (waste) pointing to a 'Biogas' icon (flame), which then points to a 'Flaring' icon (flame).</p>
<p>PROJECT SCENARIO LPG is displaced by methane extracted from biogas for hydrogen production.</p>	 <p>The project scenario flowchart shows the same top process as the baseline. The bottom process starts with 'Disposal' and 'Lagoon' icons pointing to a 'Biogas' icon, which then points to a 'Hydrogen' icon (factory). This 'Hydrogen' icon then branches to a 'Hydrogen' icon (flame) and a 'CO2' icon. The 'Flaring' icon from the baseline is crossed out with a large 'X'.</p>

AMS-III.P. Recovery and utilization of waste gas in refinery facilities

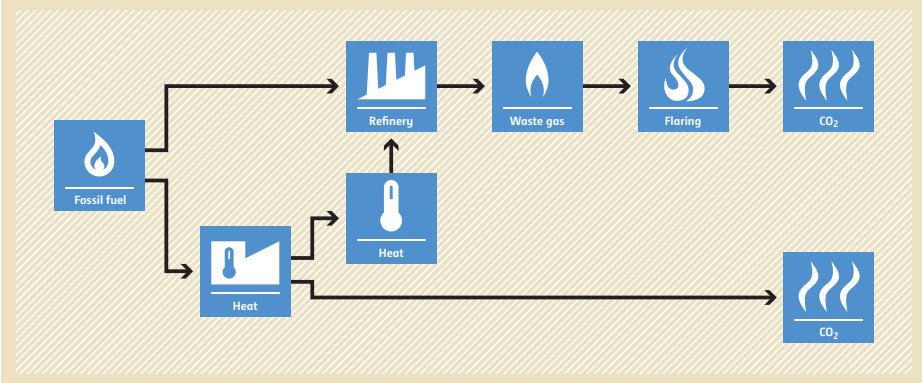
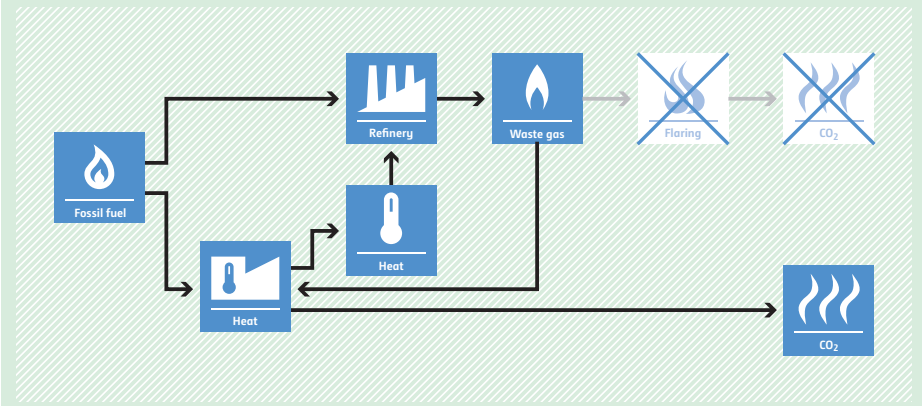
<p>Typical project(s)</p>	<p>Implementation of waste gas recovery in an existing refinery, where waste gas is currently being flared, to generate process heat in element process(es).</p>
<p>Type of GHG emissions mitigation action</p>	<ul style="list-style-type: none"> • Energy efficiency. • Displacement of more-GHG-intensive heat production.
<p>Important conditions under which the methodology is applicable</p>	<ul style="list-style-type: none"> • Proof that the recovered waste gas in the absence of the project was flared (evidence for the last three years). Baseline emissions are capped either at the historical three-year average or its estimation; • Waste gas is not combined with additional fuel gas or refinery gas between recovery and its mixing with a fuel-gas system or its direct use; • The project does not lead to an increase in production capacity of the refinery facility; • The recovery of waste gas may be a new initiative or an incremental gain in an existing practice. If the project is an incremental gain, the difference in the technology before and after implementation of the project should be clearly shown.
<p>Important parameters</p>	<p>At validation:</p> <ul style="list-style-type: none"> • Historical annual average amount of waste gas sent to flares; • Efficiencies of the process heating device using the recovered waste gas compared to that using fossil fuel. <p>Monitored:</p> <ul style="list-style-type: none"> • Data needed to calculate the emission factors of electrical energy consumed by the project, either from the captive power plant or imported from grid as well as the amount and composition of recovered waste gas (e.g. density, LHV) and data needed to calculate the emission factors from fossil fuels used for process heating and steam generation within the refinery.
<p>BASELINE SCENARIO Element process(es) will continue to supply process heat, using fossil fuel. The waste gases from the refinery are flared.</p>	 <p>The diagram shows a flow from 'Fossil fuel' to 'Heat'. This 'Heat' is used by a 'Refinery'. The 'Refinery' produces 'Waste gas', which is then sent to 'Flaring', resulting in 'CO2' emissions.</p>
<p>PROJECT SCENARIO Element process(es) will be fuelled with waste gas, replacing fossil fuel usage.</p>	 <p>The diagram shows a flow from 'Fossil fuel' to 'Heat'. This 'Heat' is used by a 'Refinery'. The 'Refinery' produces 'Waste gas', which is then used to generate 'Heat', replacing the fossil fuel. The 'Waste gas' is not flared, resulting in reduced 'CO2' emissions.</p>

AMS-III.Q. Waste energy recovery (gas/heat/pressure) projects

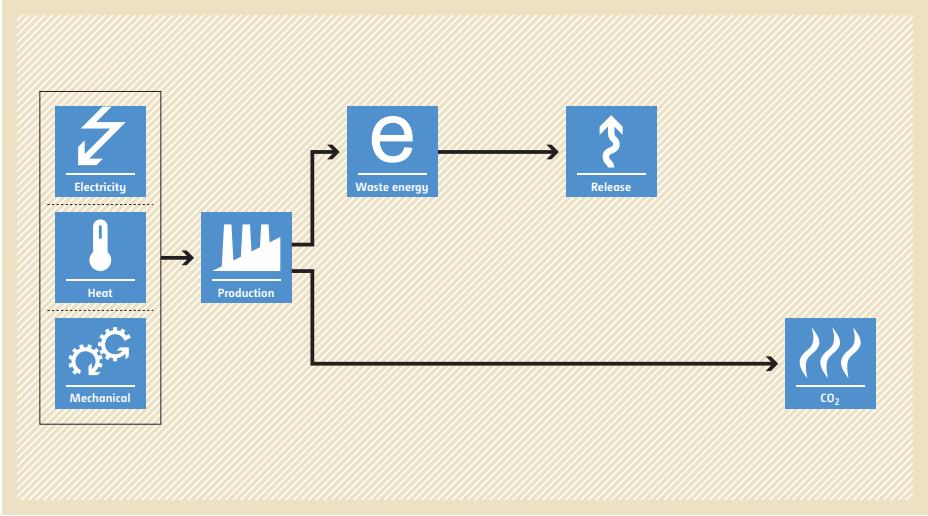
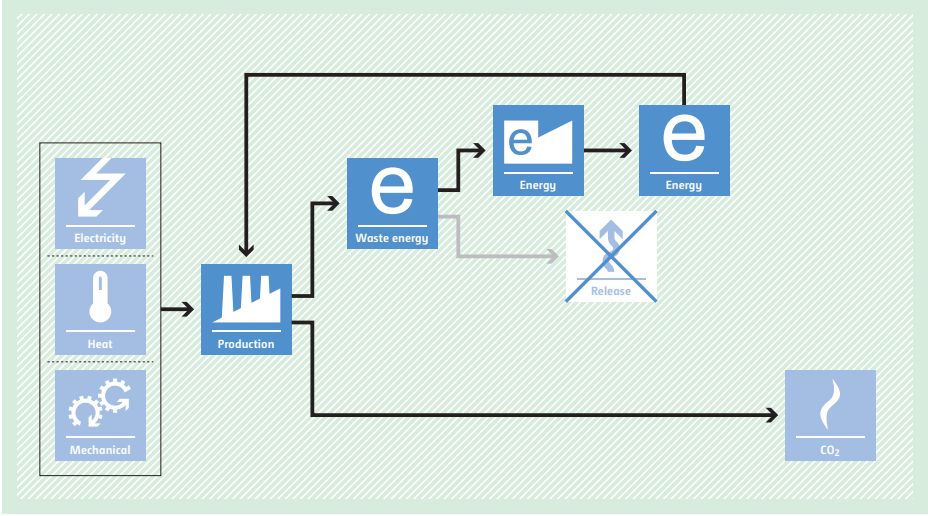
<p>Typical project(s)</p>	<p>Utilization of waste gas and/or waste heat at existing facilities and convert the waste energy into useful energy, which may be for cogeneration, generation of electricity, direct use as process heat, generation of heat in an element process or generation of mechanical energy.</p>
<p>Type of GHG emissions mitigation action</p>	<ul style="list-style-type: none"> • Energy efficiency. <p>Reduction of GHG emissions by energy recovery.</p>
<p>Important conditions under which the methodology is applicable</p>	<ul style="list-style-type: none"> • If the project activity is implemented at an existing facility, demonstration of the use of waste energy in the absence of the project activity shall be based on historic information; • It shall be demonstrated that the waste energy utilized in the project activity would have been flared or released into the atmosphere in the absence of the project activity.
<p>Important parameters</p>	<p>Monitored:</p> <ul style="list-style-type: none"> • Thermal/electrical/mechanical energy produced; • Amount of waste gas or the amount of energy contained in the waste heat or waste pressure.
<p>BASELINE SCENARIO Energy is obtained from GHG-intensive energy sources (e.g. electricity is obtained from a specific existing power plant or from the grid, mechanical energy is obtained by electric motors and heat from a fossil-fuel-based element process) and some energy is wasted in the production process and released.</p>	 <p>The diagram illustrates the baseline scenario. On the left, three boxes represent energy sources: Electricity (lightning bolt icon), Heat (thermometer icon), and Mechanical (gears icon). Arrows from these boxes point to a central 'Production' box (factory icon). From the 'Production' box, three arrows branch out: one to a 'Waste energy' box (letter 'e' icon), one to a 'Release' box (upward arrow icon), and one to a 'CO2' box (wavy lines icon).</p>
<p>PROJECT SCENARIO Waste energy is utilized to produce electrical/thermal/mechanical energy to displace GHG-intensive energy sources.</p>	 <p>The diagram illustrates the project scenario. On the left, three boxes represent energy sources: Electricity (lightning bolt icon), Heat (thermometer icon), and Mechanical (gears icon). Arrows from these boxes point to a central 'Production' box (factory icon). From the 'Production' box, four arrows branch out: one to a 'Waste energy' box (letter 'e' icon), one to an 'Energy' box (letter 'e' icon), one to a 'Release' box (upward arrow icon with a large 'X' over it), and one to a 'CO2' box (wavy lines icon). An additional arrow loops from the 'Waste energy' box back to the 'Production' box, indicating its reuse. Another arrow loops from the 'Energy' box back to the 'Production' box, indicating its reuse. The 'Release' box is crossed out, indicating that waste energy is no longer released.</p>

AMS-III.R. Methane recovery in agricultural activities at household/small farm level



<p>Typical project(s)</p>	<p>Recovery and destruction of methane from manure and wastes from agricultural activities through: Installation of a methane recovery and combustion system to an existing source of methane emissions; or, change of the management practice of an organic waste or raw material in order to achieve controlled anaerobic digestion that is equipped with methane recovery and combustion system.</p>
<p>Type of GHG emissions mitigation action</p>	<ul style="list-style-type: none"> • GHG destruction; • Fuel switch. <p>Destruction of methane and displacement of more-GHG-intensive energy generation.</p>
<p>Important conditions under which the methodology is applicable</p>	<ul style="list-style-type: none"> • Limited to measures at individual households or small farms (e.g. installation of a domestic biogas digester); • The sludge shall be handled aerobically; • All the methane collected by the recovery system shall be destroyed; • Applicable only in combination with AMS-I.C., and/or AMS-I.I. and/or AMS-I.E.
<p>Important parameters</p>	<p>Monitored:</p> <ul style="list-style-type: none"> • Inspection of the project systems; • Number of systems operating; • Annual average animal population; • Amount of waste/animal manure generated on the farm and the amount of waste/animal manure fed into the system e.g. biogas digester; • Proper soil application (not resulting in methane emissions) of the final sludge verified on a sampling basis.
<p>BASELINE SCENARIO Biomass and other organic matter are left to decay anaerobically and methane is emitted into the atmosphere.</p>	<pre> graph LR subgraph Inputs B[Biomass] M[Manure] end B --> D[Disposal] M --> D D --> Biogas Biogas --> Release Release --> CH4 </pre>
<p>PROJECT SCENARIO Methane is recovered and destroyed or used. In case of energetic use of biogas, displacement of more-GHG-intensive energy generation.</p>	<pre> graph LR subgraph Inputs B[Biomass] M[Manure] end B --> D1[Digester] M --> D1 B --> D2[Disposal] M --> D2 D1 --> Biogas1[Biogas] D2 --> Biogas2[Biogas] Biogas1 --> Heat Biogas2 --> Heat Biogas1 --> Release Biogas2 --> Release Release --> CH4 style Release stroke-dasharray: 5 5 style CH4 stroke-dasharray: 5 5 </pre>

AMS-III.S. Introduction of low-emission vehicles/technologies to commercial vehicle fleets

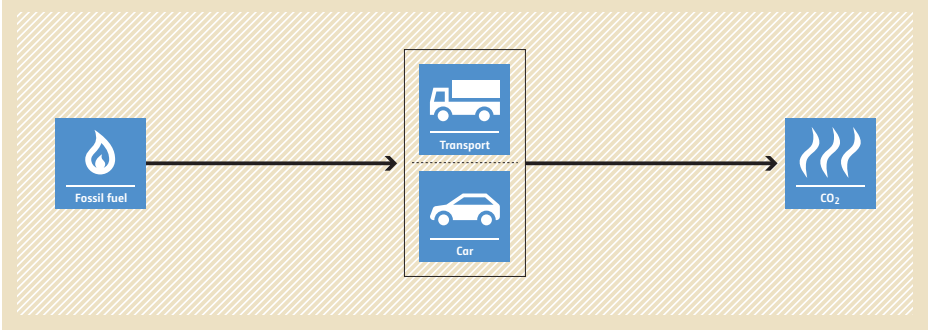
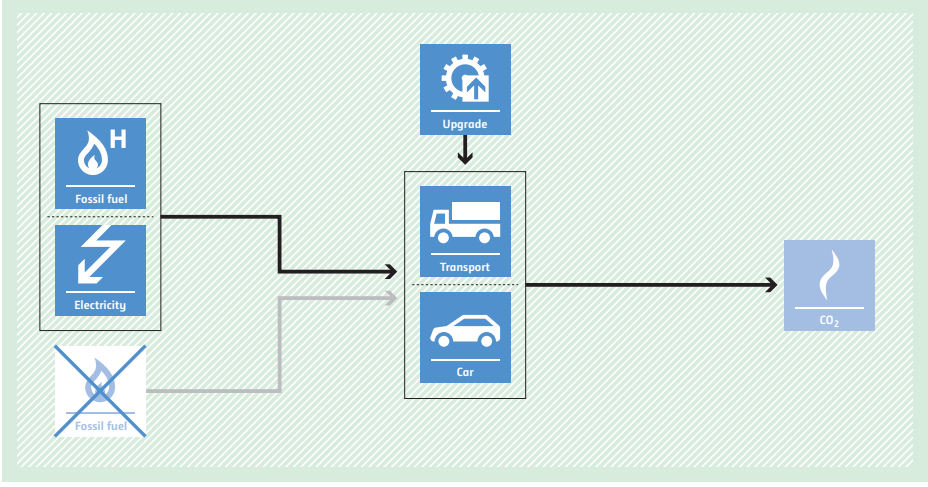
<p>Typical project(s)</p>	<p>Introduction and operation of new less-greenhouse-gas-emitting vehicles (e.g. CNG, LPG, electric or hybrid) for commercial passengers and freight transport, operating on routes with comparable conditions. Retrofitting of existing vehicles is also applicable.</p>
<p>Type of GHG emissions mitigation action</p>	<ul style="list-style-type: none"> • Fuel switch. • Displacement of more-GHG-intensive vehicles.
<p>Important conditions under which the methodology is applicable</p>	<ul style="list-style-type: none"> • The overall level of service provided on comparable routes before project implementation shall remain the same and a modal shift in transport is not eligible; • There is no significant change in tariff discernible from their natural trend, which could lead to change in patterns of vehicle use; • The frequency of operation of the vehicles is not decreased; • The characteristics of the travel route – distance, start and end points and the route itself and/or the capacity introduced by the project is sufficient to service the level of passenger/freight transportation previously provided.
<p>Important parameters</p>	<p>At validation:</p> <ul style="list-style-type: none"> • Efficiency of baseline vehicles (can also be monitored ex post). <p>Monitored:</p> <ul style="list-style-type: none"> • Total annual distance travelled and passengers or goods transported by project and baseline vehicles on route; • Annual average distance of transportation per person or tonne of freight per baseline and project vehicle; • Service level in terms of total passengers or volume of goods transported on route before and after project implementation.
<p>BASELINE SCENARIO Passengers and freight are transported using more-GHG-intensive transportation modes.</p>	 <p>The diagram illustrates the baseline scenario. It starts with a box labeled 'Fossil fuel' containing a flame icon. An arrow points from this box to a larger box containing two smaller boxes: 'Transport' (with a truck icon) and 'Car' (with a car icon). A second arrow points from this larger box to a final box labeled 'CO₂' with a flame icon.</p>
<p>PROJECT SCENARIO Passengers and freight are transported using new less-greenhouse-gas-emitting vehicles or retrofitted existing vehicles on routes.</p>	 <p>The diagram illustrates the project scenario. On the left, there are three boxes: 'Fossil fuel' (flame icon), 'Electricity' (lightning bolt icon), and a crossed-out 'Fossil fuel' box. An arrow from 'Electricity' and an arrow from the crossed-out 'Fossil fuel' box both point to a central box containing 'Transport' (truck icon) and 'Car' (car icon). Above this central box is a box labeled 'Upgrade' with a gear icon, and an arrow points from 'Upgrade' down to the central box. A final arrow points from the central box to a box labeled 'CO₂' (flame icon).</p>

AMS-III.T. Plant oil production and use for transport applications

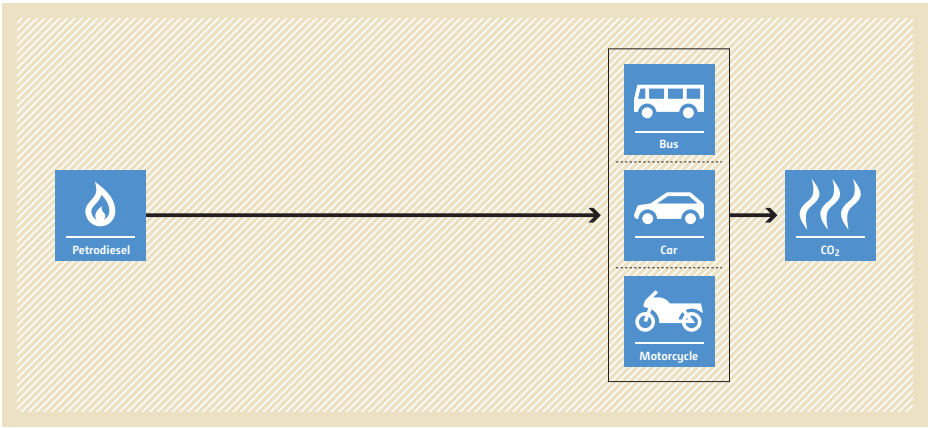
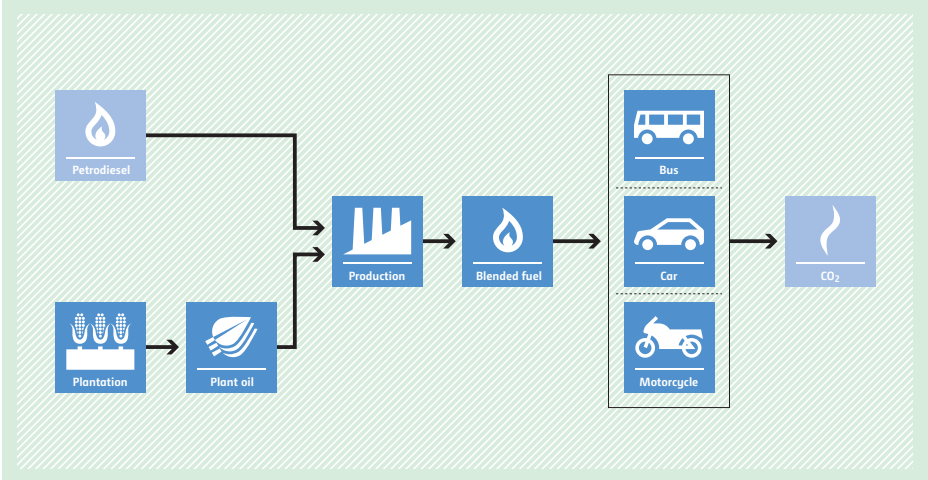
<p>Typical project(s)</p>	<p>Plant oil production that is used for transportation applications, where the plant oil is produced from pressed and filtered oilseeds from plants that are cultivated on dedicated plantations.</p>
<p>Type of GHG emissions mitigation action</p>	<ul style="list-style-type: none"> • Fuel switch. Displacement of more-GHG-intensive petrodiesel for transport.
<p>Important conditions under which the methodology is applicable</p>	<ul style="list-style-type: none"> • Oil crops are cultivated on area that is not a forest and has not been deforested during the last 10 years prior to the implementation of the project; • The establishment of dedicated plantations on peatlands is not allowed; • The plant oil is used in blends with pure petrodiesel of up to 10% by volume only or use of pure plant oil in converted vehicles; • Baseline vehicles use petrodiesel only; • No export of produced plant oil to Annex 1 countries allowed.
<p>Important parameters</p>	<p>Monitored:</p> <ul style="list-style-type: none"> • Crop harvest and oil content of the oilseeds as well as net calorific value and amount of plant oil produced by the project per crop source; • Energy use (electricity and fossil fuel) for the production of plant oil; • Use default values or alternatively monitor amount of fertilizer applied for the cultivation of plant oil per crop source; • Leakage emissions due to a shift of pre-project activities and the competing uses of biomass; • In case of use of pure plant oil it shall be monitored and verified by random sampling that the vehicles have carried out engine conversions.
<p>BASELINE SCENARIO Petrodiesel would be used in the transportation applications.</p>	 <p>The baseline scenario flowchart shows a single path from Petrodiesel (represented by a flame icon) to a box containing three vehicle types: Bus, Car, and Motorcycle. An arrow then points from this box to a CO2 (represented by a flame icon) box, indicating that petrodiesel is used in these vehicles and results in CO2 emissions.</p>
<p>PROJECT SCENARIO Oil crops are cultivated, plant oil is produced and used in the transportation applications displacing petrodiesel.</p>	 <p>The project scenario flowchart shows two parallel paths. The top path starts with Petrodiesel (flame icon) leading to Blended fuel (flame icon). The bottom path starts with Plantation (hands icon) leading to Plant oil (hands icon), which then goes to Production (factory icon) and Blended fuel (flame icon). From the Blended fuel box, an arrow points to a box containing Bus, Car, and Motorcycle icons, which then flows to a CO2 (flame icon) box, indicating that the blended fuel is used in these vehicles and results in CO2 emissions.</p>

AMS-III.U. Cable Cars for Mass Rapid Transit System (MRTS)



<p>Typical project(s)</p>	<p>Construction and operation of cable cars for urban transport of passengers substituting traditional road-based transport trips. Extensions of existing cable cars are not allowed.</p>
<p>Type of GHG emissions mitigation action</p>	<ul style="list-style-type: none"> • Energy efficiency; • Fuel switch. <p>Displacement of more-GHG-intensive vehicles.</p>
<p>Important conditions under which the methodology is applicable</p>	<ul style="list-style-type: none"> • The origin and final destination of the cable cars are accessible by road; • Fuels used in the baseline and/or the project are electricity, gaseous or liquid fossil fuels. If biofuels are used, the baseline and the project emissions should be adjusted accordingly; • The analysis of possible baseline scenario alternatives shall demonstrate that a continuation of the current public transport system is the most plausible baseline scenario.
<p>Important parameters</p>	<p>At validation:</p> <ul style="list-style-type: none"> • Occupancy rate of vehicles category; • If applicable: grid emission factor (can also be monitored ex post). <p>Monitored:</p> <ul style="list-style-type: none"> • Total passengers transported by the project; • By survey: trip distance of passengers using the baseline mode and the trip distance of passengers using the project mode from their trip origin to the project entry station and from project exit station to their final destination; • By survey: share of the passengers that would have used the baseline mode; • Share of the passengers using the project mode from trip origin to the project entry station and from project exit station to their final destination; • Quantity of electricity consumed by the cable car for traction.
<p>BASILINE SCENARIO Passengers are transported under mixed traffic conditions using a diverse transport system involving buses, trains, cars, non-motorized transport modes, etc.</p>	<p>The diagram illustrates the baseline scenario with four transport modes: Train, Bus, Car, and Motorcycle. Each mode is represented by a blue icon in a box. Arrows from each of these boxes converge and point towards a larger blue box on the right containing a flame icon and the label 'CO2', representing the total emissions from these modes.</p>
<p>PROJECT SCENARIO Passengers are transported using cable cars, thus reducing fossil fuel consumption and GHG emissions.</p>	<p>The diagram illustrates the project scenario. It includes the same four transport modes as the baseline (Train, Bus, Car, Motorcycle) plus a new 'Cable car' mode represented by a blue icon in a box. Arrows from the Train, Bus, and Motorcycle boxes converge and point to a 'CO2' box. Arrows from the Cable car box and the Car box also point to the 'CO2' box. This visualizes the displacement of some baseline modes by the cable car project.</p>

AMS-III.V. Decrease of coke consumption in blast furnace by installing dust/sludge recycling system in steel works

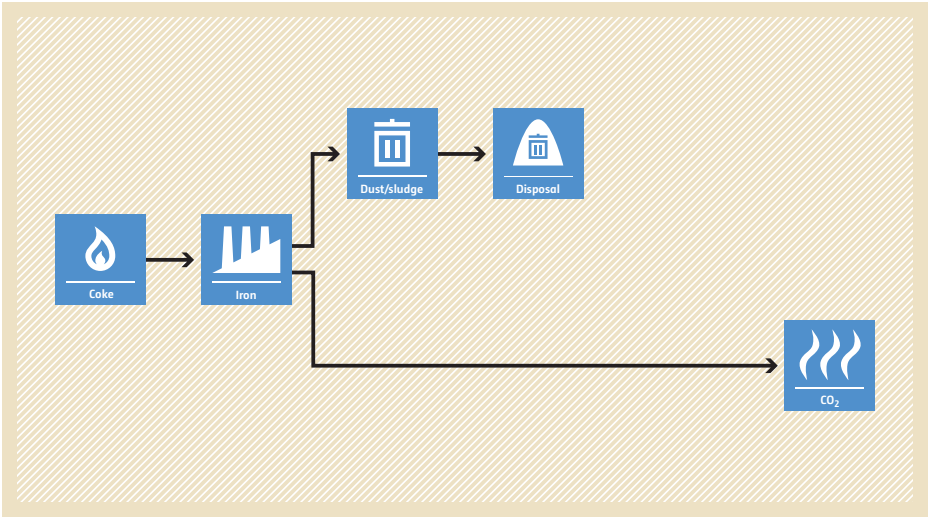
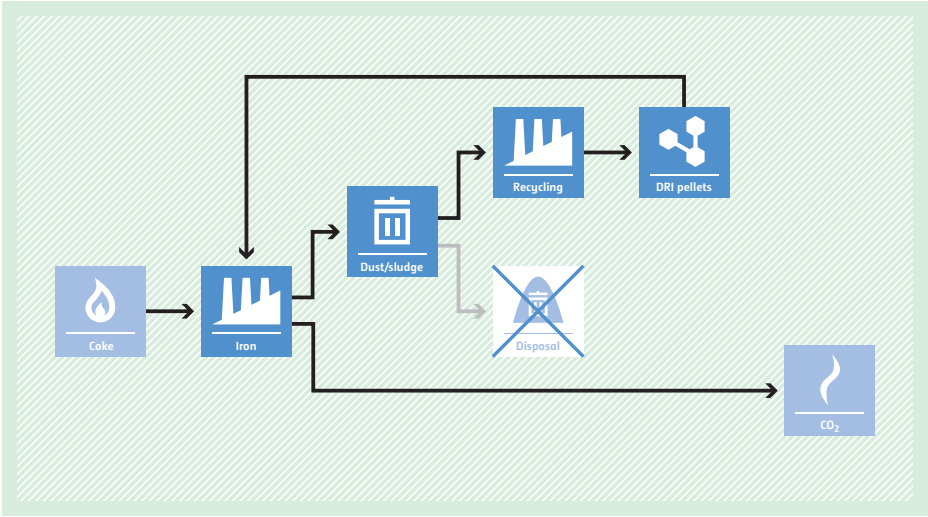
<p>Typical project(s)</p>	<p>Introduction of dust/sludge-recycling system such as Rotary Hearth Furnace (RHF), Waelz, and Primus to produce DRI pellet, which is fed into the blast furnace of steel works in order to reduce coke consumption.</p>
<p>Type of GHG emissions mitigation action</p>	<ul style="list-style-type: none"> • Energy efficiency. <p>Decreased use of coke as reducing agent by recycling dust/sludge in the form of DRI pellets.</p>
<p>Important conditions under which the methodology is applicable</p>	<ul style="list-style-type: none"> • The dust/sludge is not currently utilized inside the works but sold outside and/or land filled; • “Alternative material” that can be used by the “outside user” instead of the dust/sludge is abundant in the country/region; • Only steel works commissioned before September 26, 2008 are eligible.
<p>Important parameters</p>	<p>At validation:</p> <ul style="list-style-type: none"> • Historical average of pig iron production and coke consumption. <p>Monitored:</p> <ul style="list-style-type: none"> • Annual quantity of pig iron production, coke consumption; • Quantity and iron content of DRI pellet fed into the blast furnace; • Fuel and electricity use; • Fraction of carbon in coke fed into the blast furnace (tonnes of C per tonne of coke).
<p>BASELINE SCENARIO High amounts of coke are used to produce pig iron, thus leading to high CO₂ emissions. Dust/sludge from steel works is sold to outside user and/or land-filled.</p>	 <p>The diagram illustrates the baseline scenario. It starts with 'Coke' (represented by a flame icon) being used to produce 'Iron' (represented by a factory icon). From the 'Iron' production stage, two paths emerge: one leading to 'Dust/Sludge' (represented by a trash can icon) which then goes to 'Disposal' (represented by a trash can icon), and another leading directly to 'CO₂' emissions (represented by a flame icon).</p>
<p>PROJECT SCENARIO Less coke is used to produce pig iron. This leads to lower CO₂ emissions. Dust/sludge is transformed into DRI pellets which are reused as input in this pig iron production.</p>	 <p>The diagram illustrates the project scenario. It starts with 'Coke' (represented by a flame icon) being used to produce 'Iron' (represented by a factory icon). From the 'Iron' production stage, two paths emerge: one leading to 'Dust/Sludge' (represented by a trash can icon) which then goes to 'Recycling' (represented by a factory icon), and another leading directly to 'CO₂' emissions (represented by a flame icon). The 'Recycling' stage produces 'DRI pellets' (represented by a factory icon), which are then fed back into the 'Iron' production stage as an input. The 'Disposal' stage is crossed out with a large 'X'.</p>

AMS-III.W. Methane capture and destruction in non-hydrocarbon mining activities

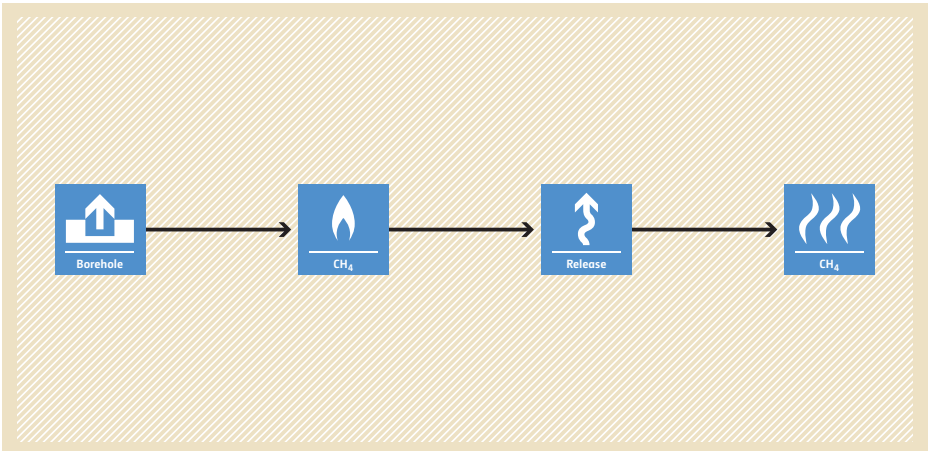
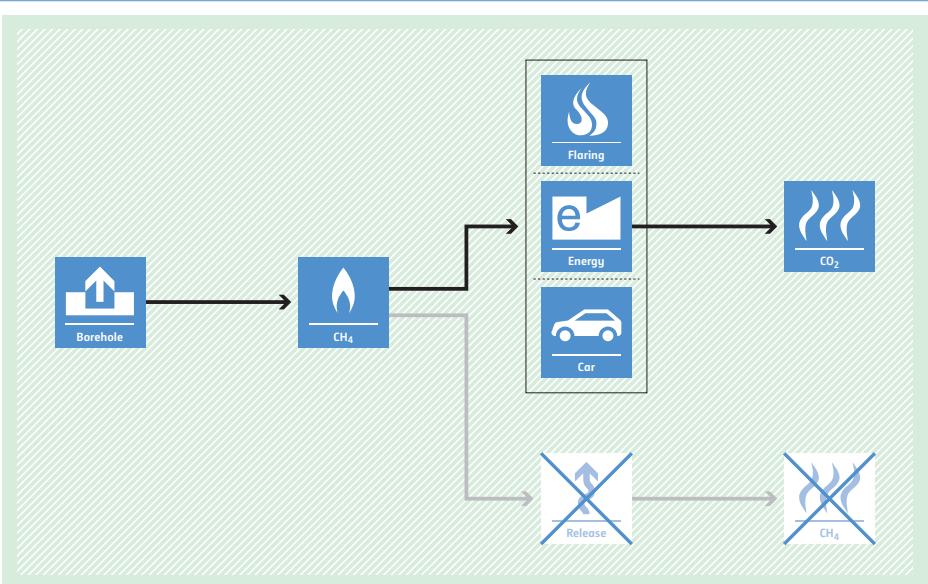
<p>Typical project(s)</p>	<p>This methodology comprises activities that capture methane released from holes drilled into geological formations specifically for mineral exploration and prospecting.</p>
<p>Type of GHG emissions mitigation action</p>	<ul style="list-style-type: none"> • GHG destruction. <p>Capture and combustion/utilization of methane released from boreholes.</p>
<p>Important conditions under which the methodology is applicable</p>	<ul style="list-style-type: none"> • Abandoned or decommissioned mines, as well as open cast mines are excluded. Coal extraction mines or oil shale, as well as boreholes or wells opened for gas/oil exploration or extraction do not qualify under this methodology; • This methodology is applicable for structures installed, or boreholes drilled before end of 2001, or for structures installed, or boreholes drilled after 2001, where it can be demonstrated that the structures or the boreholes were part of an exploration plan; • Maximum outside diameter of the boreholes should not exceed 134 mm; • This methodology excludes measures that would increase the amount of methane emissions from the boreholes beyond the natural release as would occur in the baseline.
<p>Important parameters</p>	<p>Monitored:</p> <ul style="list-style-type: none"> • Vehicle fuel provided by the project activity; • Amount of methane actually flared; • Electricity and/or heat produced by the project activity; • Consumption of grid electricity and/or fossil fuel by the project.
<p>BASELINE SCENARIO Methane is emitted from boreholes into the atmosphere.</p>	 <p>The baseline scenario flowchart shows a linear process starting with a 'Borehole' icon (a house with an upward arrow), followed by an arrow to a 'CH₄' icon (a flame), another arrow to a 'Release' icon (a vertical arrow with a curved path), and a final arrow to another 'CH₄' icon (a flame). The entire flowchart is set against a light brown background with a diagonal hatching pattern.</p>
<p>PROJECT SCENARIO Capture and destruction of methane from boreholes.</p>	 <p>The project scenario flowchart shows a linear process starting with a 'Borehole' icon (a house with an upward arrow), followed by an arrow to a 'CH₄' icon (a flame). From this 'CH₄' icon, the path splits into two. One path goes to a box containing three icons: 'Flaring' (flame), 'Energy' (letter 'e'), and 'Car' (car). An arrow from this box points to a 'CO₂' icon (flame). The other path from the 'CH₄' icon goes to a 'Release' icon (vertical arrow with curved path), which is crossed out with a large 'X'. An arrow from this 'Release' icon points to a 'CH₄' icon (flame), which is also crossed out with a large 'X'. The entire flowchart is set against a light green background with a diagonal hatching pattern.</p>

AMS-III.X. Energy efficiency and HFC-134a recovery in residential refrigerators



<p>Typical project(s)</p>	<p>Replacement of existing, functional domestic refrigerators by more-efficient units and recovery/destruction of HFCs from the refrigerant and the foam.</p>
<p>Type of GHG emissions mitigation action</p>	<ul style="list-style-type: none"> • Energy efficiency; • GHG emission avoidance; • GHG destruction. <p>GHG emission avoidance by re-use of refrigerant or GHG destruction combined with an increase in energy efficiency.</p>
<p>Important conditions under which the methodology is applicable</p>	<ul style="list-style-type: none"> • Project refrigerants and foam-blowing agents have no ozone depleting potential and a global warming potential lower than 15; • All refrigerator replacements take place within just one year of project start; • Project and baseline refrigerators are electrically driven; • Project refrigerators have an average volume capacity of at least 80% of the baseline refrigerators.
<p>Important parameters</p>	<p>Monitored:</p> <ul style="list-style-type: none"> • Number of refrigerators distributed and their electricity consumption; • Quantity of HFC reclaimed; • Specific electricity consumption from replaced refrigerators.
<p>BASILINE SCENARIO Use of large amounts of electricity by refrigerators and HFC emissions from the refrigerators.</p>	<pre> graph LR FF[Fossil fuel] --> Grid[Grid] Grid --> Elec[Electricity] Grid --> CO2[CO2] Elec --> Ref[Refrigerators] Ref --> HFC[HFC] </pre>
<p>PROJECT SCENARIO Use of lower amounts of electricity by refrigerators and reduced HFC emissions from refrigerators.</p>	<pre> graph LR FF[Fossil fuel] --> Grid[Grid] Grid --> Upgrade[Upgrade] Grid --> CO2[CO2] Upgrade --> Ref[Refrigerators] Grid --> Ref Ref --> HFC[HFC] </pre>

AMS-III.Y. Methane avoidance through separation of solids from wastewater or manure treatment systems

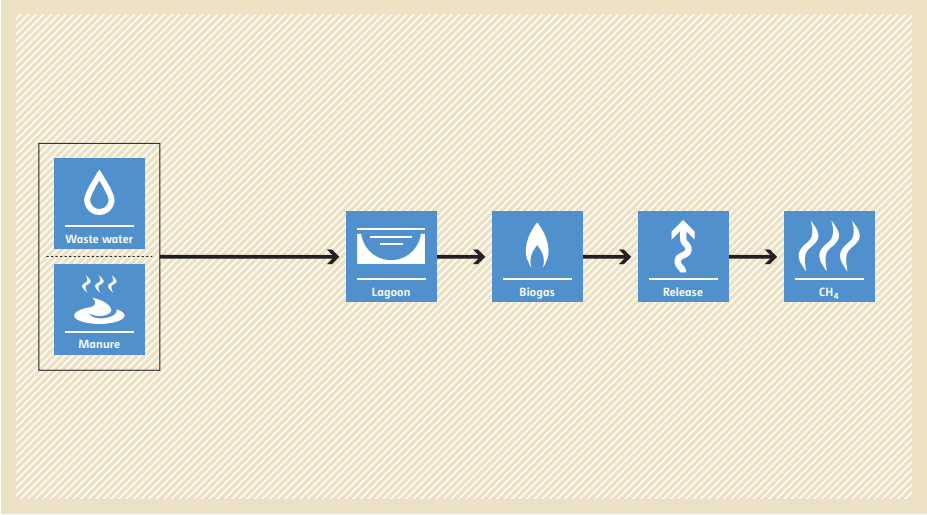
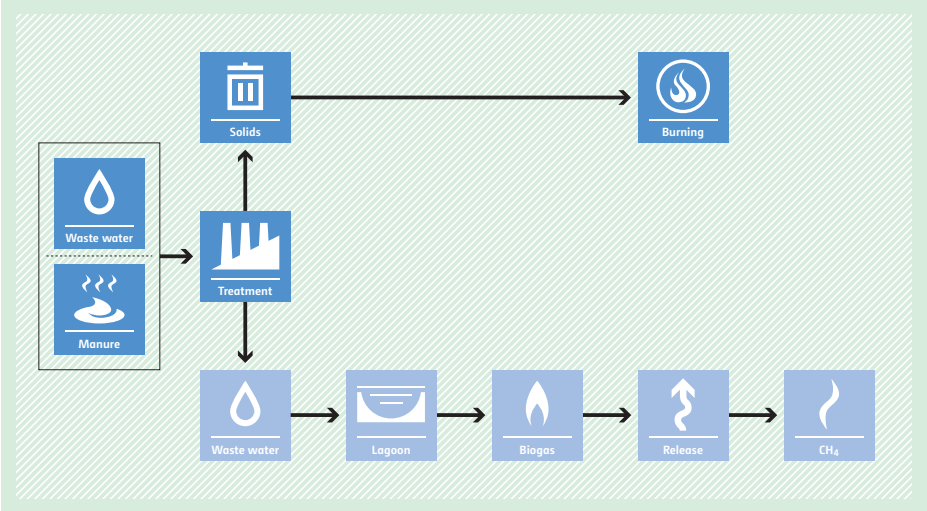
<p>Typical project(s)</p>	<p>Avoidance or reduction of methane production from anaerobic wastewater treatments systems and anaerobic manure management systems where the volatile solids are removed and the separated solids are further treated/used/disposed to result in lower methane emissions.</p>
<p>Type of GHG emissions mitigation action</p>	<ul style="list-style-type: none"> • GHG emission avoidance. <p>Avoidance of methane emissions.</p>
<p>Important conditions under which the methodology is applicable</p>	<ul style="list-style-type: none"> • The project does not recover or combust biogas; • Technology for solid separation shall be one or a combination of mechanical solid/liquid separation technologies and thermal treatment technologies, and not by gravity; • Dry matter content of the separated solids shall remain higher than 20% and separation shall be achieved in less than 24 hours; • The liquid fraction from the project solid separation system shall be treated either in a baseline facility or in a treatment system with lower methane conversion factor than the baseline system.
<p>Important parameters</p>	<p>Monitored:</p> <ul style="list-style-type: none"> • For manure management systems, number of animals, their type and their individual volatile solids excretion; • For wastewater systems, the flow of wastewater entering the system and the COD load of the wastewater.
<p>BASILINE SCENARIO Solids in manure or wastewater would be treated in a manure management system or wastewater treatment facility without methane recover, and methane is emitted into the atmosphere.</p>	 <p>The baseline scenario flowchart shows a linear process starting with 'Waste water' and 'Manure' entering a box. An arrow points to a 'Lagoon' box, followed by 'Biogas', 'Release', and finally 'CH4' emissions.</p>
<p>PROJECT SCENARIO Less methane is emitted due to separation and treatment of solids.</p>	 <p>The project scenario flowchart shows 'Waste water' and 'Manure' entering a 'Treatment' facility. From 'Treatment', 'Solids' are sent to 'Burning'. The remaining liquid goes to a 'Lagoon', then 'Biogas', 'Release', and finally 'CH4' emissions.</p>

AMS-III.Z. Fuel switch, process improvement and energy efficiency in brick manufacture



<p>Typical project(s)</p>	<p>Switch to a more-energy-efficient brick production process and/or switch from fossil fuel to renewable biomass or less-carbon-intensive fossil fuel.</p>
<p>Type of GHG emissions mitigation action</p>	<ul style="list-style-type: none"> • Energy efficiency; • Renewable energy; • Fuel or feedstock switch. <p>Reduction of emissions from decreased energy consumption per brick produced and from the use of fuels with lower carbon intensity, either at an existing brick kiln or at a new facility.</p>
<p>Important conditions under which the methodology is applicable</p>	<ul style="list-style-type: none"> • Quality of the project bricks should be comparable to or better than the baseline bricks; • No renewable biomass has been used in the existing project facility during the last three years immediately prior to the start of the project activity; • For project activities involving changes in raw materials, the raw materials to be utilized shall be abundant in the country/region; • For project activities using crops from renewable biomass origin as fuel, the crops shall be cultivated at dedicated plantations; • Exemption of demonstration of debundling is allowed under certain conditions.
<p>Important parameters</p>	<p>At validation:</p> <ul style="list-style-type: none"> • Historical brick output and fuel consumption. <p>Monitored:</p> <ul style="list-style-type: none"> • Production output; • Quantity and type of fuels used; • Quantity of raw and additive materials; • Quality of the project bricks.
<p>BASELINE SCENARIO Brick production using more-carbon-intensive fuel and energy-intensive technology.</p>	<p>The diagram shows a linear process flow. It starts with a blue square icon containing a flame and the text 'Fossil fuel'. An arrow points to a blue square icon containing a factory silhouette and the text 'Brick'. A second arrow points to a blue square icon containing three wavy lines and the text 'CO₂'.</p>
<p>PROJECT SCENARIO Brick production using less-carbon-intensive fuel or biomass in a more-efficient facility.</p>	<p>The diagram shows a more complex process flow. On the left, there are three blue square icons: the top one has a flame and 'Fossil fuel', the middle one has a leaf and 'Biomass', and the bottom one has a flame and 'Fossil fuel'. Arrows from these three icons converge into a single arrow pointing to a blue square icon with a factory silhouette and 'Brick'. Above this 'Brick' icon is another blue square icon with a gear and an upward arrow, labeled 'Upgrade'. An arrow points from the 'Upgrade' icon down to the 'Brick' icon. Finally, an arrow points from the 'Brick' icon to a blue square icon with wavy lines and 'CO₂'.</p>

AMS-III.AA. Transportation energy efficiency activities using retrofit technologies

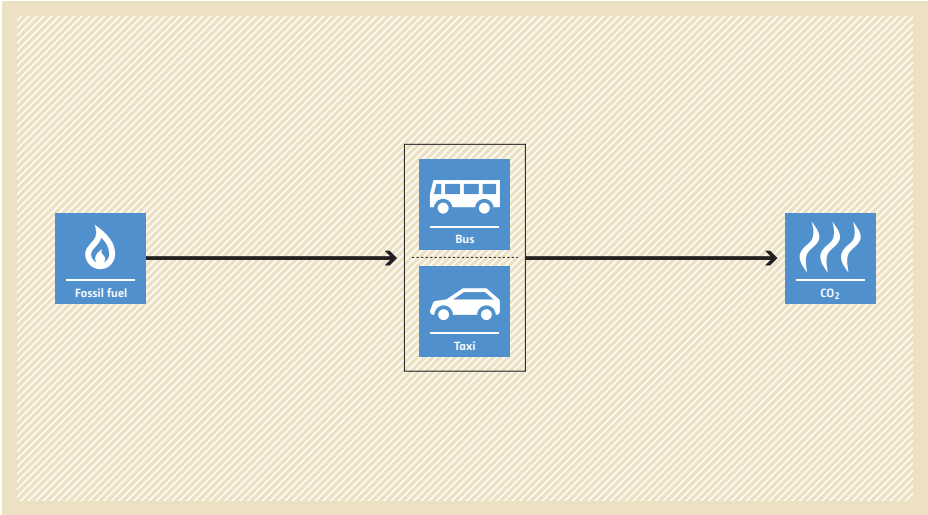
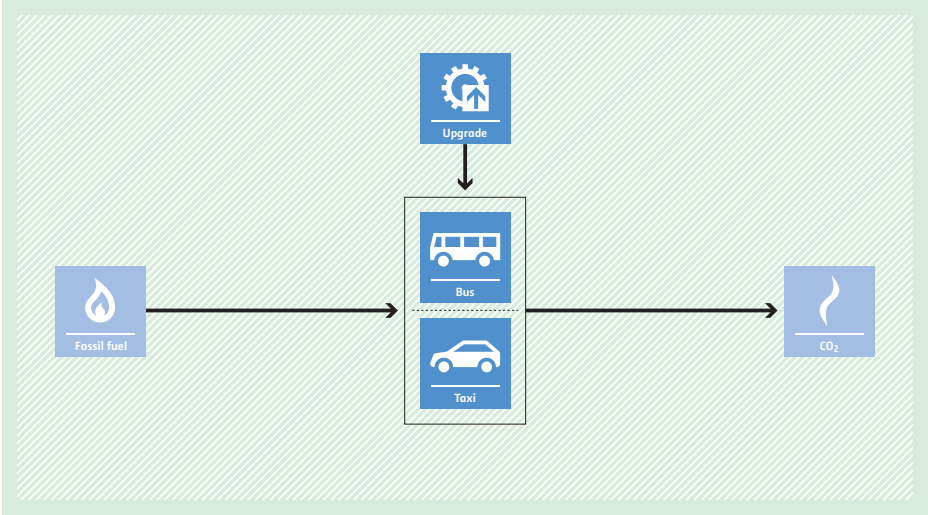
<p>Typical project(s)</p>	<p>Retrofit of the engine of existing/used vehicles for commercial passengers transport (e.g. buses, motorized rickshaws, taxis) which results in increased fuel efficiency of the vehicles.</p>
<p>Type of GHG emissions mitigation action</p>	<ul style="list-style-type: none"> Energy efficiency. <p>Energy efficiency measures in transportation reduce GHG emissions due to decreased fuel consumption.</p>
<p>Important conditions under which the methodology is applicable</p>	<ul style="list-style-type: none"> The vehicles for passenger transportation are of the same type, use the same fuel and single type of retrofit technology; The methodology is not applicable to brand new vehicles/technologies (e.g. CNG, LPG, electric or hybrid vehicles); The vehicles shall operate during the baseline and project on comparable routes with similar traffic situations.
<p>Important parameters</p>	<p>At validation:</p> <ul style="list-style-type: none"> Determination of the remaining technical lifetime of the retrofitted vehicles. <p>Monitored:</p> <ul style="list-style-type: none"> Fuel efficiency of the baseline and project vehicle; Annual average distance travelled by project vehicles; Number of theoretically operating project vehicles; Share of project vehicles in operation.
<p>BASELINE SCENARIO Passengers are transported using less-fuel-efficient vehicles.</p>	 <p>The diagram illustrates the baseline scenario. It features a central box containing two icons: a bus labeled 'Bus' and a car labeled 'Taxi'. To the left of this box is a blue square icon with a flame and the text 'Fossil fuel'. An arrow points from the 'Fossil fuel' icon to the central box. To the right of the central box is another blue square icon with three wavy lines and the text 'CO2'. An arrow points from the central box to the 'CO2' icon. The entire process is set against a light brown background with a diagonal hatching pattern.</p>
<p>PROJECT SCENARIO Passengers are transported using retrofitted more-fuel-efficient vehicles.</p>	 <p>The diagram illustrates the project scenario. It features a central box containing two icons: a bus labeled 'Bus' and a car labeled 'Taxi'. Above this box is a blue square icon with a gear and the text 'Upgrade'. An arrow points from the 'Upgrade' icon down to the central box. To the left of the central box is a blue square icon with a flame and the text 'Fossil fuel'. An arrow points from the 'Fossil fuel' icon to the central box. To the right of the central box is another blue square icon with three wavy lines and the text 'CO2'. An arrow points from the central box to the 'CO2' icon. The entire process is set against a light green background with a diagonal hatching pattern.</p>

AMS-III.AB. Avoidance of HFC emissions in standalone commercial refrigeration cabinets

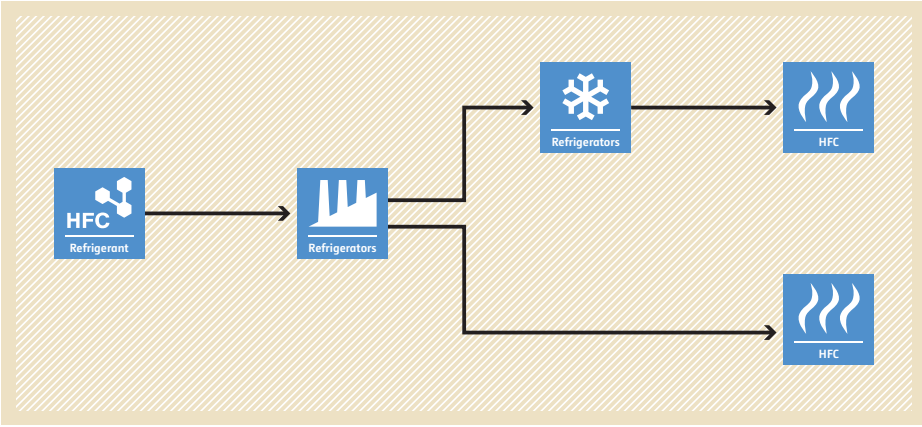
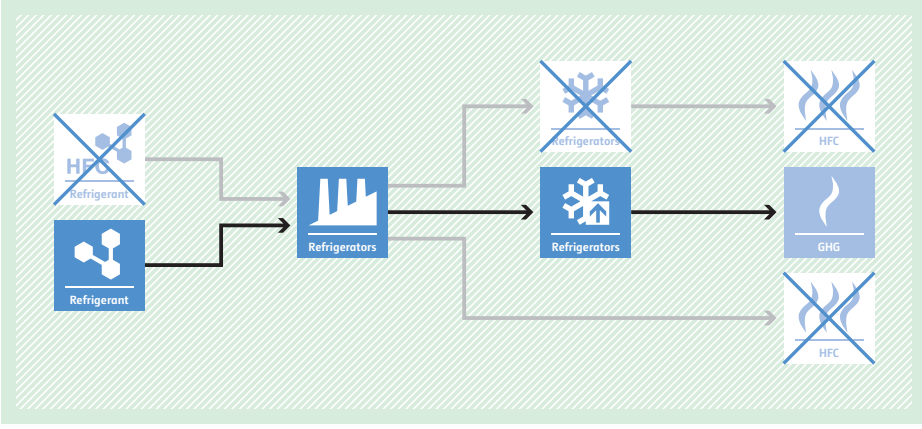
<p>Typical project(s)</p>	<p>Introduction of new commercial standalone refrigeration cabinets using refrigerants with low global warming potential (GWP).</p>
<p>Type of GHG emissions mitigation action</p>	<ul style="list-style-type: none"> • GHG emission avoidance; • Feedstock switch. <p>Avoidance of fugitive emissions of refrigerants with high GWP (e.g. HFC-134a) through the use of refrigerants with low GWP.</p>
<p>Important conditions under which the methodology is applicable</p>	<ul style="list-style-type: none"> • Cabinets in the project case utilize one type of refrigerants and foam blowing agents having no ozone depleting potential (ODP) and low GWP; • The cabinets introduced by the project are equally or more energy efficient than the cabinets that would have been used in the absence of project; • The project proponent has been producing or managing commercial refrigeration cabinets charged with refrigerants with high GWP for at least three years and has not been using refrigerants with a low GWP in significant quantities prior to the start of the project.
<p>Important parameters</p>	<p>At validation:</p> <ul style="list-style-type: none"> • Nameplate initial refrigerant charge for each refrigeration cabinet model; • Fugitive emissions of refrigerants during manufacturing, servicing/maintenance, and disposal of refrigeration cabinets. <p>Monitored:</p> <ul style="list-style-type: none"> • Number of refrigeration cabinets that are manufactured, put into use, under servicing/maintenance, and decommissioned and disposed.
<p>BASELINE SCENARIO Fugitive HFC emissions with high GWP during manufacturing, usage and servicing, and disposal of refrigeration cabinets.</p>	 <p>The diagram illustrates the baseline scenario. It starts with 'HFC Refrigerant' (represented by a blue icon with a molecular structure) entering a 'Refrigerators' factory (represented by a blue icon with a factory silhouette). From the factory, the flow splits into two paths: one leading to 'Refrigerators' (represented by a blue icon with a snowflake) and another leading to 'HFC' (represented by a blue icon with three wavy lines). Both paths then lead to 'HFC' emissions (represented by a blue icon with three wavy lines), indicating that both the production and the use of the refrigerators result in high-GWP HFC emissions.</p>
<p>PROJECT SCENARIO Fugitive emissions of refrigerants with low GWP during manufacturing, usage and servicing, and disposal of refrigeration cabinets.</p>	 <p>The diagram illustrates the project scenario. It shows a switch from 'HFC Refrigerant' (represented by a blue icon with a molecular structure and a large 'X' over it) to a generic 'Refrigerant' (represented by a blue icon with a molecular structure). This generic refrigerant enters the 'Refrigerators' factory (represented by a blue icon with a factory silhouette). From the factory, the flow splits into two paths: one leading to 'Refrigerators' (represented by a blue icon with a snowflake and a large 'X' over it) and another leading to 'HFC' (represented by a blue icon with three wavy lines and a large 'X' over it). The path to 'Refrigerators' then leads to 'GHG' emissions (represented by a blue icon with a flame and a large 'X' over it), while the path to 'HFC' leads to 'HFC' emissions (represented by a blue icon with three wavy lines and a large 'X' over it). This indicates that the project scenario results in lower GWP emissions during usage and servicing, but still has HFC emissions during disposal.</p>

AMS-III.AC. Electricity and/or heat generation using fuel cell

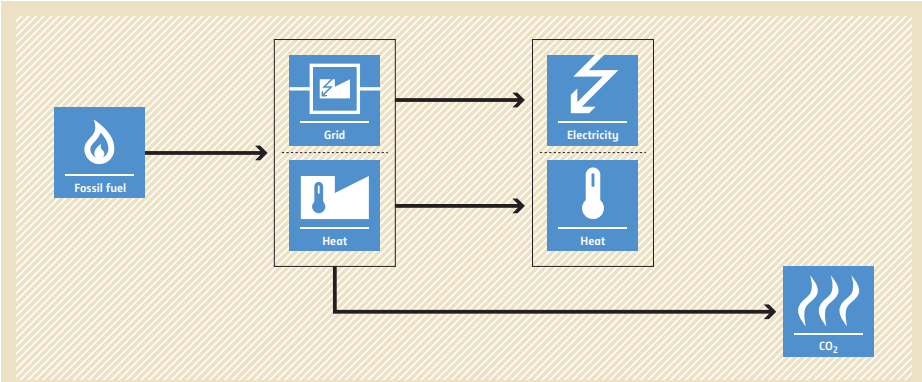
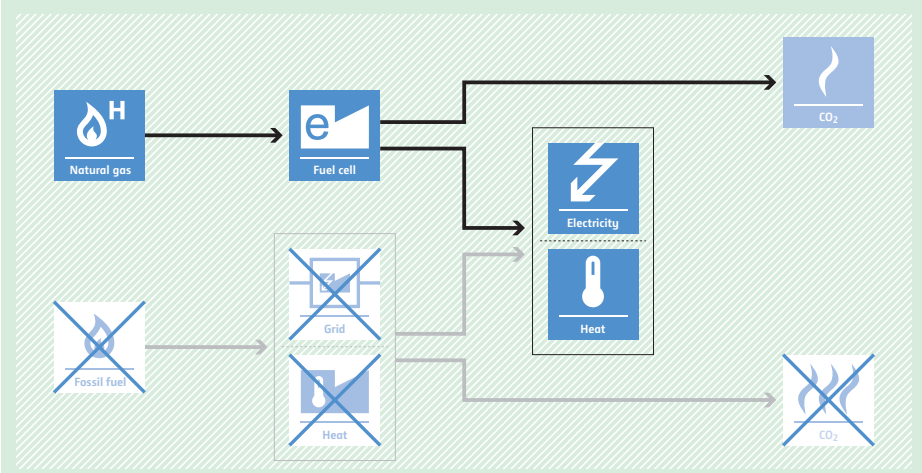
<p>Typical project(s)</p>	<p>Generation of electricity and/or heat using fuel cell technology using natural gas as feedstock to supply electricity to existing or new users or to a grid.</p>
<p>Type of GHG emissions mitigation action</p>	<ul style="list-style-type: none"> • Energy efficiency. • Displacement of more-GHG-intensive electricity or electricity and heat generation.
<p>Important conditions under which the methodology is applicable</p>	<ul style="list-style-type: none"> • Not applicable where energy produced by fuel cell is used for transportation application; • Electricity and/or steam/heat delivered to several facilities require a contract specifying that only the facility generating the energy can claim CERs; • Natural gas is sufficiently available in the region or country; • If the project includes the replacement of the cell or any part of it (the molten carbonate, the electrodes, etc.) during the crediting period, there shall be no significant changes in the efficiency or capacity of the fuel cell technology used in the project due to the replacement. The lifetime of the fuel cell shall be assessed in accordance with the procedures described in General Guideline to SSC methodologies.
<p>Important parameters</p>	<p>At validation:</p> <ul style="list-style-type: none"> • If applicable: grid emission factor (can also be monitored ex post). <p>Monitored:</p> <ul style="list-style-type: none"> • Monitoring of energy (heat/power) generation and consumption of the project; • Consumption and composition of feedstock (e.g. natural gas) used for hydrogen production.
<p>BASELINE SCENARIO Other technologies that would have been used in absence of the project and/or grid imports are supplying electricity and/or heat to new users or to a grid.</p>	 <p>The baseline scenario flowchart shows fossil fuel being converted into grid electricity and heat. The grid electricity is then used to generate more electricity and heat, which eventually leads to CO2 emissions.</p>
<p>PROJECT SCENARIO Natural gas as feedstock is used for hydrogen production which is then used in a fuel cell technology to produce heat/electricity displacing alternative technologies and therefore reducing baseline emissions.</p>	 <p>The project scenario flowchart shows natural gas being converted into hydrogen, which is then used in a fuel cell to produce electricity and heat. This process displaces the fossil fuel, grid, and heat from the baseline scenario, resulting in reduced CO2 emissions.</p>

AMS-III.AD. Emission reductions in hydraulic lime production

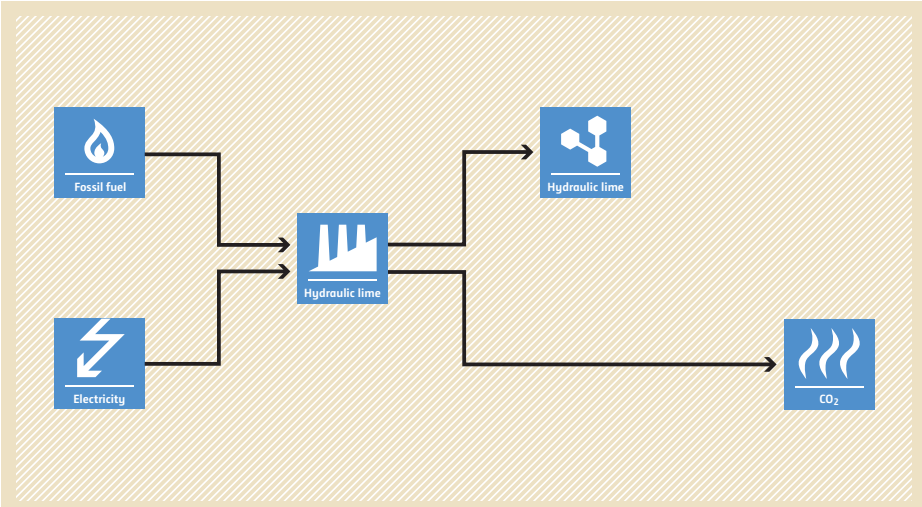
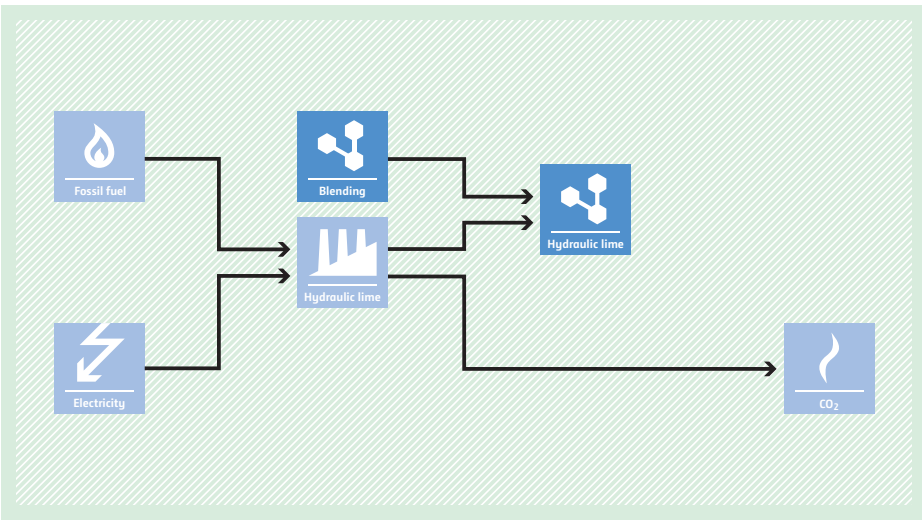
<p>Typical project(s)</p>	<p>Production of alternative hydraulic lime for construction purposes by blending a certain amount of conventional hydraulic lime with alternative material and additives.</p>
<p>Type of GHG emissions mitigation action</p>	<ul style="list-style-type: none"> • Feedstock switch. <p>Reduction of production of hydraulic lime and thereby reduction of fossil fuel use and electricity consumption during the production process.</p>
<p>Important conditions under which the methodology is applicable</p>	<ul style="list-style-type: none"> • Quality of alternative hydraulic lime is the same or better than the hydraulic lime; • There is no other allocation or use for the amount of alternative material used by the project and there is sufficient availability; • The project is in an existing plant; • This methodology is limited to domestically sold output of the project plant and excludes export of alternative hydraulic lime.
<p>Important parameters</p>	<ul style="list-style-type: none"> • Alternative hydraulic lime meets or exceeds the quality standards of the baseline hydraulic lime; • Total production of alternative lime and hydraulic lime (intermediate product) consumption of alternative lime and additives; • Fuel and electricity consumption.
<p>BASELINE SCENARIO Production of hydraulic lime using conventional process consuming high amount of energy.</p>	
<p>PROJECT SCENARIO Reduced fossil fuel input in hydraulic lime production due to blending with additives.</p>	

AMS-III.AE. Energy efficiency and renewable energy measures in new residential buildings



<p>Typical project(s)</p>	<p>Installation of energy efficiency and optional renewable power generation measures in new, grid-connected residential buildings.</p>
<p>Type of GHG emissions mitigation action</p>	<ul style="list-style-type: none"> • Energy efficiency; • Renewable energy. <p>Electricity savings through energy efficiency improvement and optional use of renewable power.</p>
<p>Important conditions under which the methodology is applicable</p>	<ul style="list-style-type: none"> • Emission reductions shall only be claimed for grid electricity savings; • Emission reductions through biomass energy supply cannot be claimed; • Project buildings must be newly constructed residential buildings, and shall not use fossil or biomass fuels for space heating or cooling; • Refrigerant used in energy-efficient equipment under the project, if any, shall be CFC-free.
<p>Important parameters</p>	<p>At validation:</p> <ul style="list-style-type: none"> • Monthly electricity consumption of baseline and project residences; • Grid emission factor (can also be monitored ex post); • Monthly HDD and CDD for baseline and project residences; • Baseline and project residence characteristics. <p>Monitored:</p> <ul style="list-style-type: none"> • Update of the parameters provided for validation; • Annual records of project residence occupancy.
<p>BASELINE SCENARIO Less-efficient use of electricity in buildings.</p>	<pre> graph LR FF[Fossil fuel] --> G[Grid] G --> E[Electricity] G --> CO2[CO2] E --> B[Buildings] </pre>
<p>PROJECT SCENARIO More-efficient use of electricity and optional use of renewable power in buildings.</p>	<pre> graph LR FF[Fossil fuel] --> G[Grid] R[Renewable] --> E2[Electricity] G --> E1[Electricity] G --> CO2[CO2] E1 --> B[Buildings] E2 --> B U[Upgrade] --> B </pre>

AMS-III.AF. Avoidance of methane emissions through excavating and composting of partially decayed municipal solid waste (MSW)

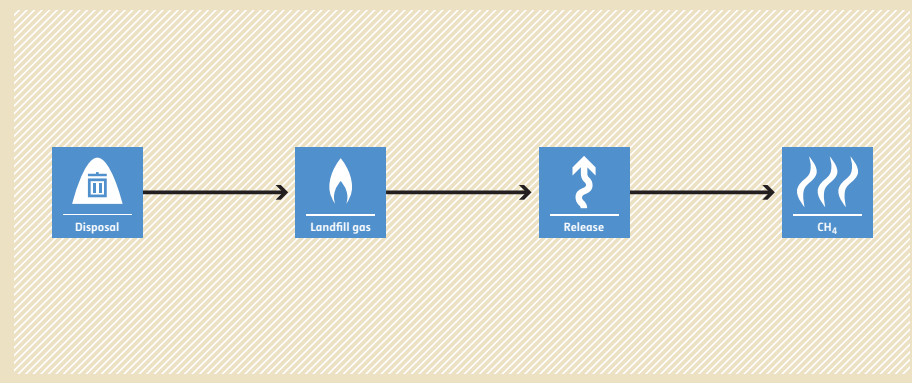
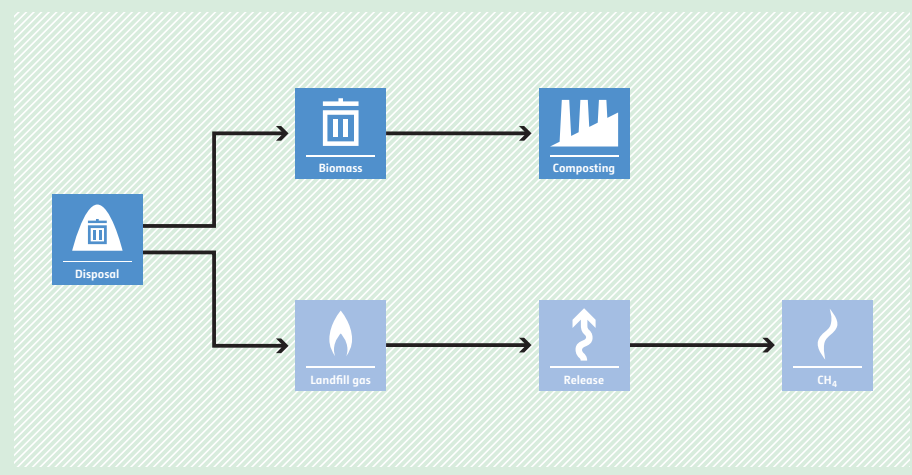
<p>Typical project(s)</p>	<p>Avoidance of methane emissions from MSW that is already deposited in a closed solid waste disposal site (SWDS) without methane recovery. Due to the project, non-inert material will be composted through pre-aeration, excavation and separation of the MSW in the closed SWDS, so that methane emissions will be avoided.</p>
<p>Type of GHG emissions mitigation action</p>	<ul style="list-style-type: none"> • GHG emission avoidance. <p>Methane emissions from anaerobic decay of organic matter in municipal solid waste is avoided by alternative waste treatment (i.e. composting).</p>
<p>Important conditions under which the methodology is applicable</p>	<ul style="list-style-type: none"> • This methodology is applicable if the aerobic pre-treatment is realized either through high pressure air injection enriched with oxygen (20-40% vol.) or low pressure aeration using ambient air; • The existing regulations do not require the capture and flaring of landfill gas of closed SWDS; • The composting process is realized at enclosed chambers or roofed sites, outdoor composting is not applicable.
<p>Important parameters</p>	<p>Monitored:</p> <ul style="list-style-type: none"> • Quantity of raw waste removed and quantity of compost produced; • Parameters related to transport, e.g. truck capacity; • Parameters related to methane generation potential of the non-inert fraction of the partially decayed, separated MSW; • Amount of non-inert waste excavated and aerobically composted; • Annual amount of fossil fuel or electricity used to operate the facilities or power auxiliary equipment.
<p>BASELINE SCENARIO MSW is left to decay within the SWDS and methane is emitted into the atmosphere.</p>	 <pre> graph LR A[Disposal] --> B[Landfill gas] B --> C[Release] C --> D[CH4] </pre>
<p>PROJECT SCENARIO Methane emissions will be avoided by applying pre-aeration and excavation of existing SWDS, followed by separation and composting of non-inert materials.</p>	 <pre> graph LR A[Disposal] --> B[Biomass] A --> C[Landfill gas] B --> D[Composting] C --> E[Release] E --> F[CH4] </pre>

AMS-III.AG. Switching from high carbon intensive grid electricity to low carbon intensive fossil fuel

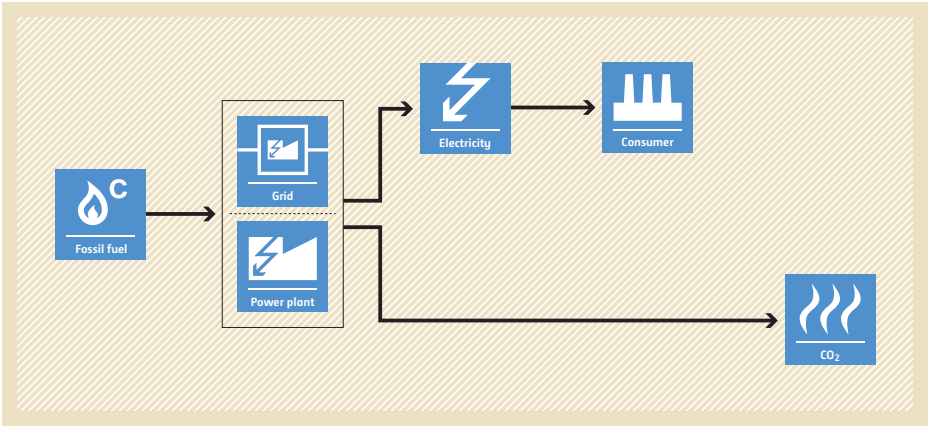
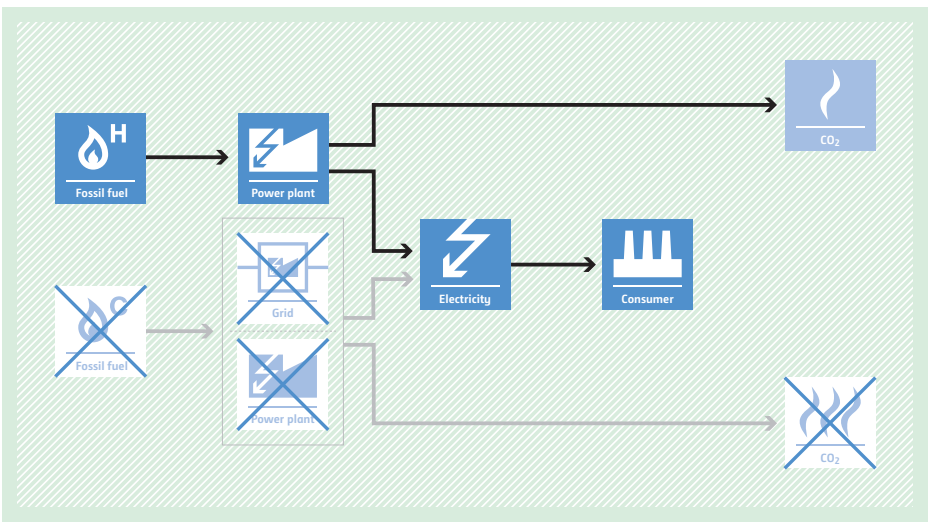
<p>Typical project(s)</p>	<p>Switch from high carbon grid electricity to electricity generation using less-carbon-intensive fossil fuel such as captive natural-gas-based power generation.</p>
<p>Type of GHG emissions mitigation action</p>	<ul style="list-style-type: none"> Fuel switch. <p>Switch to a less-carbon-intensive fuel for power generation.</p>
<p>Important conditions under which the methodology is applicable</p>	<ul style="list-style-type: none"> The project is primarily the switch from fossil-fuel-based electricity generation, supplied partly or entirely by the grid, to a single, low-GHG fossil fuel at greenfield or existing facilities; Cogeneration (e.g. gas turbine with heat recovery) is allowed provided that the emission reductions are claimed only for the electricity output; Export of electricity to a grid is not part of the project boundary; Project does not result in integrated process change.
<p>Important parameters</p>	<p>At validation:</p> <ul style="list-style-type: none"> Historical power generation for existing baseline plants; Quantity of fossil fuels for existing baseline plants; Grid emission factor can also be monitored ex post. <hr/> <p>Monitored:</p> <ul style="list-style-type: none"> Quantity of fossil fuel use; The output of element process for electricity exported to other facilities shall be monitored in the recipient end.
<p>BASELINE SCENARIO Use of carbon-intensive fuel to generate electricity.</p>	 <p>The diagram illustrates the baseline scenario. On the left, a box labeled 'Fossil fuel' with a 'C' (carbon) icon has an arrow pointing to a central box. This central box is divided into two sections: 'Grid' (top) and 'Power plant' (bottom). From the 'Grid' section, an arrow points to a box labeled 'Electricity' with a lightning bolt icon, which then has an arrow pointing to a box labeled 'Consumer' with a factory icon. From the 'Power plant' section, an arrow points directly to a box labeled 'CO2' with a flame icon.</p>
<p>PROJECT SCENARIO Use of a less-carbon-intensive fuel to generate electricity, which leads to a decrease in GHG emissions.</p>	 <p>The diagram illustrates the project scenario. On the left, a box labeled 'Fossil fuel' with an 'H' (hydrogen) icon has an arrow pointing to a box labeled 'Power plant' with a lightning bolt icon. From this 'Power plant', an arrow points to a box labeled 'Electricity' with a lightning bolt icon, which then has an arrow pointing to a box labeled 'Consumer' with a factory icon. From the 'Power plant', another arrow points to a box labeled 'CO2' with a flame icon. The central area of the diagram, which would correspond to the 'Grid' and 'Power plant' sections in the baseline scenario, is crossed out with a large 'X'. This crossed-out area includes a 'Fossil fuel' box with a 'C' icon, a 'Grid' box, and a 'Power plant' box. The 'CO2' box at the bottom right of this area is also crossed out with a large 'X'.</p>

AMS-III.AH. Shift from high carbon intensive fuel mix ratio to low carbon intensive fuel mix ratio

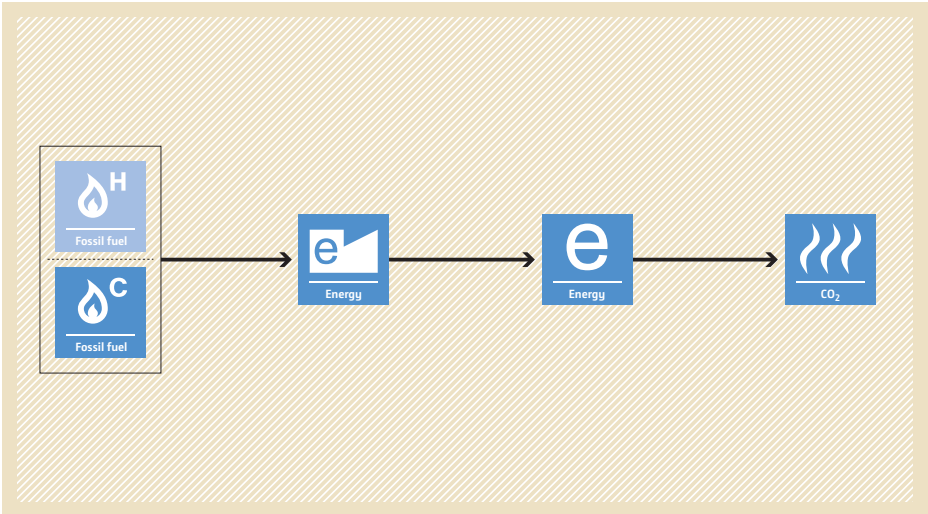
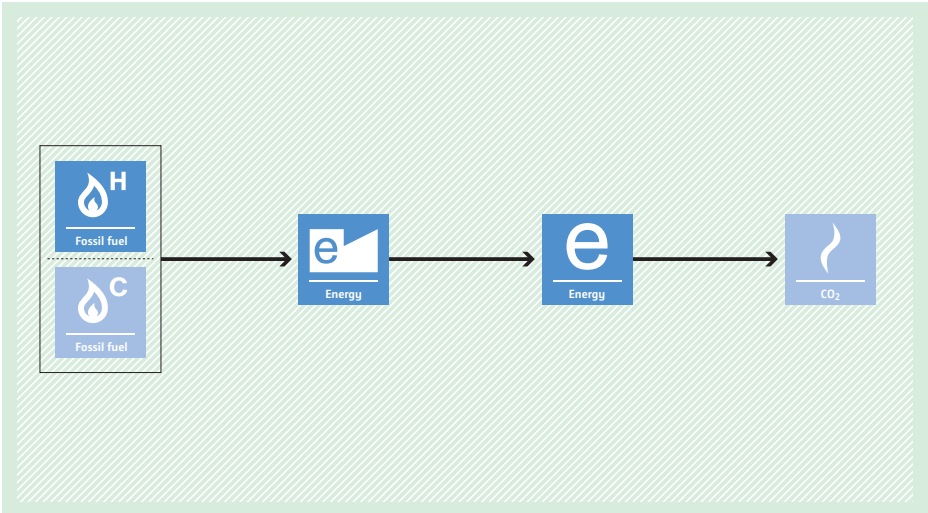
<p>Typical project(s)</p>	<p>Replacement or retrofit in order to increase the share of less-carbon-intensive fossil fuels in an element process of industrial, residential or commercial applications.</p>
<p>Type of GHG emissions mitigation action</p>	<ul style="list-style-type: none"> • Fuel switch. <p>Switch to less-carbon-intensive fuel in energy conversion processes.</p>
<p>Important conditions under which the methodology is applicable</p>	<ul style="list-style-type: none"> • Increase in the share of less-carbon-intensive fuel other than biomass or waste gas/energy; • Only energy efficiency improvements related to the fuel switch are eligible; • Only retrofit and replacements without capacity expansion and/or integrated process change are eligible.
<p>Important parameters</p>	<p>At validation:</p> <ul style="list-style-type: none"> • Quantity of fossil fuel use; • The output and efficiency of element process (e.g. heat or electricity); • Availability of all baseline fossil fuels. <p>Monitored:</p> <ul style="list-style-type: none"> • Fossil fuel and energy input to the element process; • Output of the element process and exported to the recipient end.
<p>BASILINE SCENARIO Production of energy using more-carbon-intensive fossil fuel mix.</p>	 <p>The diagram illustrates the baseline scenario. On the left, a box contains two 'Fossil fuel' icons: one with a flame and the letter 'H' (high carbon) and another with a flame and the letter 'C' (low carbon). An arrow points from this box to a blue box labeled 'Energy' with a white 'e' and a flame icon. A second arrow points to another blue box labeled 'Energy' with a white 'e' and a flame icon. A final arrow points to a blue box labeled 'CO2' with a flame icon. The entire process is set against a light brown background with a diagonal hatched pattern.</p>
<p>PROJECT SCENARIO Production of energy using less-carbon-intensive fossil fuel mix.</p>	 <p>The diagram illustrates the project scenario. On the left, a box contains two 'Fossil fuel' icons: one with a flame and the letter 'H' (high carbon) and another with a flame and the letter 'C' (low carbon). An arrow points from this box to a blue box labeled 'Energy' with a white 'e' and a flame icon. A second arrow points to another blue box labeled 'Energy' with a white 'e' and a flame icon. A final arrow points to a blue box labeled 'CO2' with a flame icon. The entire process is set against a light green background with a diagonal hatched pattern.</p>

AMS-III.A1. Emission reductions through recovery of spent sulphuric acid

<p>Typical project(s)</p>	<p>Recovery of sulphuric acid from 'spent sulphuric acid' where the neutralization of spent acid with hydrated lime or lime stone and the associated CO₂ emissions in the existing facility are avoided.</p>
<p>Type of GHG emissions mitigation action</p>	<ul style="list-style-type: none"> • GHG emission avoidance. <p>Avoidance of neutralization of spent acid and of related GHG emissions.</p>
<p>Important conditions under which the methodology is applicable</p>	<ul style="list-style-type: none"> • The project is a new sulphuric acid recovery facility; • The concentration of the spent sulphuric acid ranges from 18% w/w to 80% w/w (weight percentage); • Specific spent sulphuric acid recovery procedures are applied.
<p>Important parameters</p>	<p>At validation:</p> <ul style="list-style-type: none"> • Historical data on the quantity of spent sulphuric acid neutralized. <p>Monitored:</p> <ul style="list-style-type: none"> • Quantity and acidity of sulphuric acid recovered; • Historic energy (electricity/steam) self-generated by a neighbouring facility that will be replaced by supply of an equivalent energy by the project; • Energy displaced by the project by supply of energy to a neighbouring facility that displaces an equivalent amount of energy usage in the baseline or supplied to the grid.
<p>BASILINE SCENARIO The spent sulphuric acid is neutralized using hydrated lime, leading to CO₂ emissions.</p>	
<p>PROJECT SCENARIO No hydrated lime is used to neutralize the spent sulphuric acid. The associated CO₂ emissions are avoided.</p>	

AMS-III.AJ. Recovery and recycling of materials from solid wastes



<p>Typical project(s)</p>	<p>HDPE, LDPE and PET/PP plastic materials are recycled from municipal solid wastes (MSW) and processed into intermediate or finished products (e.g. plastic bags).</p>
<p>Type of GHG emissions mitigation action</p>	<ul style="list-style-type: none"> • Energy efficiency. <p>Reduction of production of HDPE, LDPE and PET/PP from virgin materials, thus reducing related energy consumption.</p>
<p>Important conditions under which the methodology is applicable</p>	<ul style="list-style-type: none"> • Recycling process may be accomplished manually and/or using mechanical equipment and includes washing, drying, compaction, shredding and pelletizing; • Emission reductions can only be claimed for the difference in energy use for the production of HDPE/LDPE/PET/PP products from virgin inputs versus production from recycled material; • Contractual agreement between recycling facility and manufacturing facility guarantees that only one of them claims CERs; • Three years historical data show that displaced virgin material is not imported from an Annex I country; • For recycling of PET/PP, the chemical equivalence of the recycled PET/PP to that of PET/PP made from virgin input shall be proved.
<p>Important parameters</p>	<p>Monitored:</p> <ul style="list-style-type: none"> • Quantity of each type of recycled materials sold to a manufacturing facility; • Electricity and fossil fuel consumption of the recycling facility; • Intrinsic viscosity of PET/PP.
<p>BASELINE SCENARIO HDPE, LDPE and PET/PP are produced from virgin raw material resulting in high energy consumption.</p>	
<p>PROJECT SCENARIO Production of HDPE, LDPE and PET/PP based on virgin raw material is reduced. Use of recycled material results in less energy consumption.</p>	

AMS-III.AK. Biodiesel production and use for transport applications

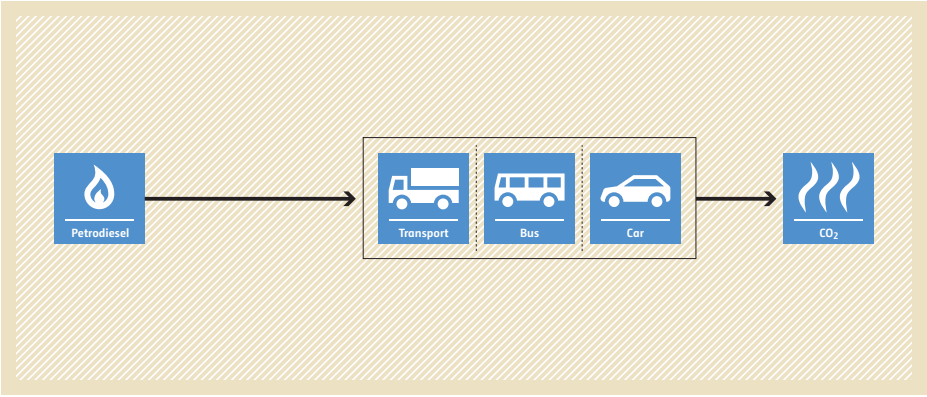
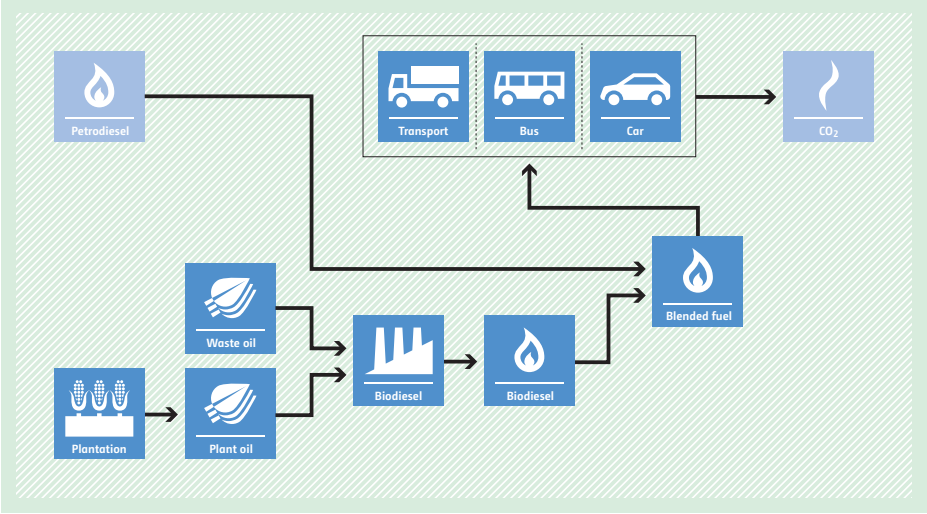
<p>Typical project(s)</p>	<p>Biodiesel production that is used for transportation applications, where the biodiesel is produced from oilseed cultivated on dedicated plantations and from waste oil/fat.</p>
<p>Type of GHG emissions mitigation action</p>	<ul style="list-style-type: none"> • Renewable energy. <p>Displacement of more-carbon-intensive fossil fuel for combustion in vehicles/ transportation applications by use of renewable biomass.</p>
<p>Important conditions under which the methodology is applicable</p>	<ul style="list-style-type: none"> • Oil crops are cultivated on area which is classified as degraded or degrading as per the “Tool for the identification of degraded or degrading lands for consideration in implementing CDM A/R project activities” or on area included in the project boundary of one or several registered A/R CDM project activities. Plantations established on peatlands are not eligible; • Export of produced biodiesel is not allowed; • The biodiesel is used in blends with diesel of up to 20 % by volume; • The biodiesel and its blends are end-used in a captive fleet of vehicles; • The alcohol used for esterification is methanol of fossil fuel origin.
<p>Important parameters</p>	<p>Monitored:</p> <ul style="list-style-type: none"> • Quantity of biodiesel produced in the project plant and consumption of biodiesel and its blends by the captive users; • Quantity of fossil fuel and electricity consumption for processing the oilseeds and the waste fat/oil to produce biodiesel; • Parameters to estimate project emissions from the cultivation of oil crops if the default values for jatropa and palm oil are not applied.
<p>BASELINE SCENARIO Petrodiesel would be used in the transportation applications.</p>	 <p>The baseline scenario flowchart shows a single path from Petrodiesel (represented by a flame icon) to a box containing icons for Transport, Bus, and Car. An arrow from this box points to a CO2 icon, indicating emissions from the use of fossil fuels.</p>
<p>PROJECT SCENARIO Oil crops are cultivated, blended biodiesel is produced and used in the transportation applications.</p>	 <p>The project scenario flowchart shows a more complex process. It starts with Plantation (crops) and Waste oil, which feed into Biodiesel production (factory icon). The resulting Biodiesel is then combined with Petrodiesel to create Blended fuel (flame icon). This Blended fuel is then used for Transport, Bus, and Car, leading to CO2 emissions. The flowchart illustrates the displacement of fossil fuels by renewable biodiesel.</p>

AMS-III.AL. Conversion from single cycle to combined cycle power generation

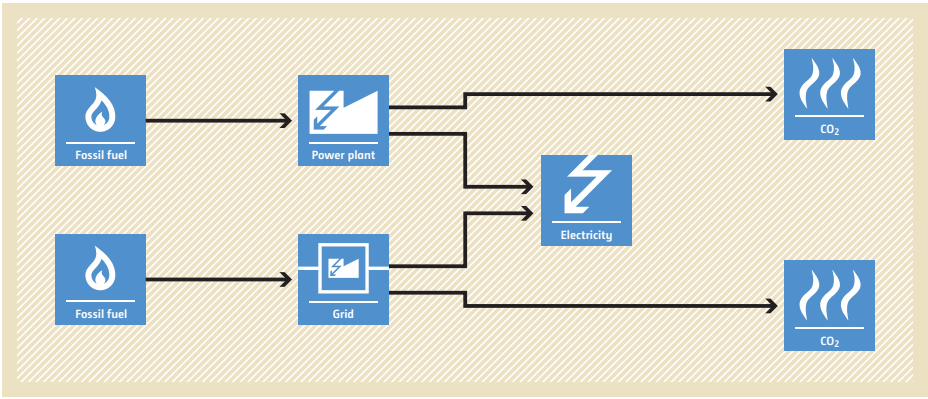
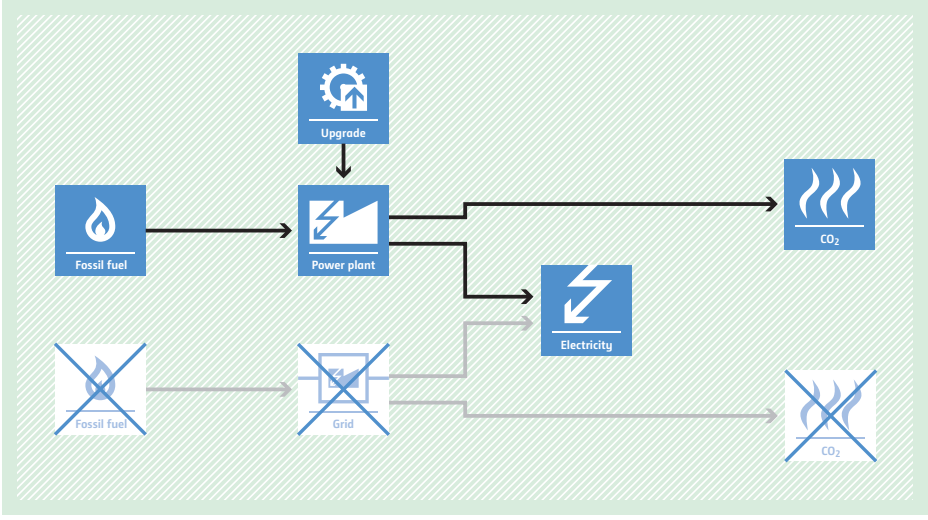
<p>Typical project(s)</p>	<p>Conversion of an existing single-cycle gas turbine(s) or internal combustion engine(s) with or without cogeneration system to a combined-cycle system with or without cogeneration to produce additional electricity for captive use and/or supply to a grid.</p>
<p>Type of GHG emissions mitigation action</p>	<ul style="list-style-type: none"> • Energy efficiency. • Fuel savings through energy efficiency improvement.
<p>Important conditions under which the methodology is applicable</p>	<ul style="list-style-type: none"> • The project utilizes excess heat (e.g. gas turbine/engine exhaust heat) that was previously unused for at least three years before the start of the project; • Useful thermal energy produced in the baseline and project is for captive use only; • The project does not involve any major overhauls to the existing single-cycle gas turbine/engine system (no increase of the lifetime or capacity of the system).
<p>Important parameters</p>	<p>At validation:</p> <ul style="list-style-type: none"> • Grid emission factor (can also be monitored ex post); • Average net annual electricity generation of the existing system in the three years immediately prior to the project start; • Average annual fuel consumption of the existing system in the three years immediately prior to the project start. <p>Monitored:</p> <ul style="list-style-type: none"> • Net electricity generated by the project; • Fuel and electricity consumed by the project; • Net thermal energy consumed by the project.
<p>BASELINE SCENARIO Electricity is generated by a single-cycle gas turbine(s)/ engine(s) with or without simultaneous generation of thermal energy (steam or hot water).</p>	 <p>The diagram illustrates the baseline scenario. It shows two parallel paths. The top path starts with 'Fossil fuel' (flame icon) entering a 'Power plant' (lightning bolt icon). From the power plant, arrows point to 'Electricity' (lightning bolt icon) and 'CO2' (flame icon). The bottom path starts with 'Fossil fuel' (flame icon) entering a 'Grid' (lightning bolt icon). From the grid, arrows point to 'Electricity' (lightning bolt icon) and 'CO2' (flame icon). The entire diagram is set against a light brown background with a diagonal line pattern.</p>
<p>PROJECT SCENARIO The existing single-cycle gas turbine(s) is converted to a combined-cycle gas turbine(s)/ engine(s) for more efficient electricity generation with or without simultaneous generation of thermal energy (steam or hot water).</p>	 <p>The diagram illustrates the project scenario. It shows an 'Upgrade' (gear icon) leading to a 'Power plant' (lightning bolt icon). The 'Fossil fuel' (flame icon) and 'Grid' (lightning bolt icon) inputs from the baseline scenario are shown as crossed-out boxes. From the upgraded power plant, arrows point to 'Electricity' (lightning bolt icon) and 'CO2' (flame icon). The 'CO2' output from the grid is also shown as a crossed-out box. The entire diagram is set against a light green background with a diagonal line pattern.</p>

AMS-III.AM. Fossil fuel switch in a cogeneration/trigeneration system

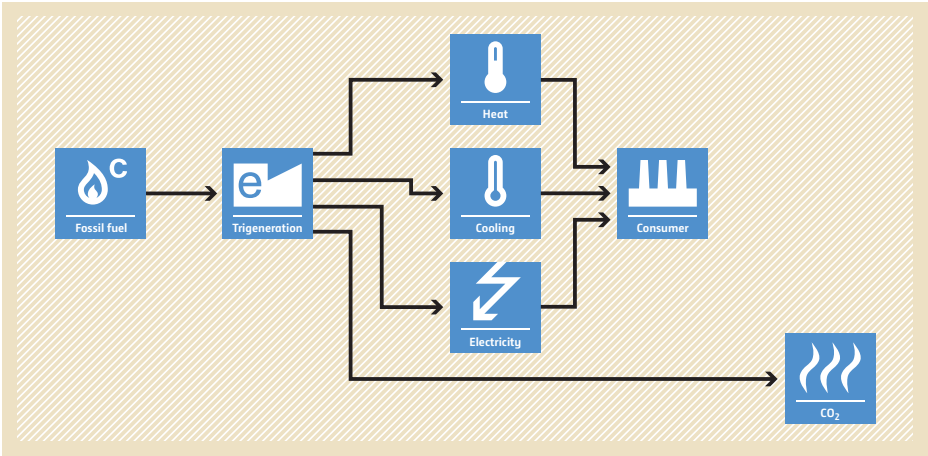
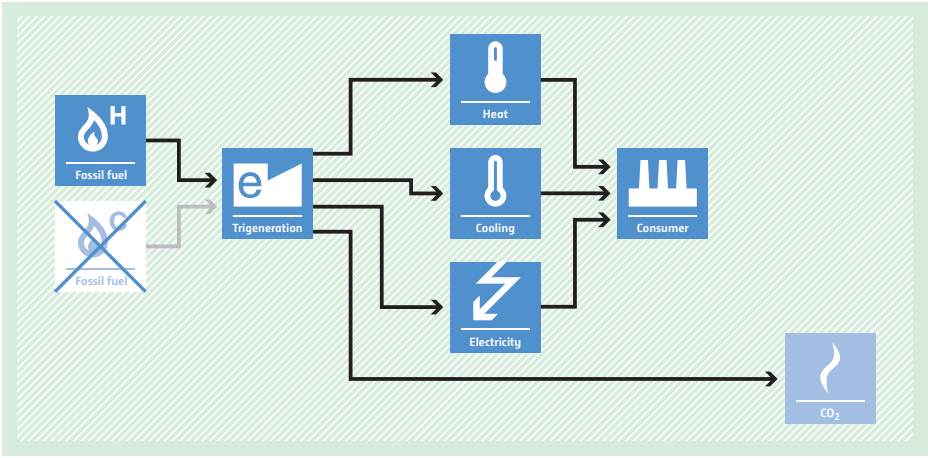
<p>Typical project(s)</p>	<p>Fossil fuel switching from a carbon-intensive fossil fuel to a low-carbon-intensive fossil fuel in a new or existing cogeneration/trigeneration system (e.g. switching from coal to natural gas in a cogeneration/trigeneration unit).</p>
<p>Type of GHG emissions mitigation action</p>	<ul style="list-style-type: none"> • Fuel switch. • Displacement of a more-GHG-intensive service.
<p>Important conditions under which the methodology is applicable</p>	<ul style="list-style-type: none"> • Fuel input efficiency (thermal and electricity output/fuel input) is better (or at least equal) to the baseline one; • Specific auxiliary energy consumption does not change more than +/-10%; • For existing cogeneration/trigeneration systems at least three years of historical data prior to the start of the project (one year if less than three years operational history); • If installations of cooling equipment use refrigerants, such refrigerants must have no or negligible global warming potential (GWP) and no or negligible ozone depleting potential (ODP); • The project does not impact any production processes or other level of service provided.
<p>Important parameters</p>	<ul style="list-style-type: none"> • Amount of net electricity produced; • Quantity of fossil fuel consumed; • Thermal energy (mass flow, temperature, pressure for heat/cooling) delivered by the project.
<p>BASELINE SCENARIO Use of carbon-intensive fossil fuel in cogeneration/trigeneration system for production of power/heat/cooling.</p>	 <p>The diagram illustrates the baseline scenario. On the left, a box labeled 'Fossil fuel' with a flame icon and a 'C' superscript indicates the use of carbon-intensive fuel. An arrow points to a 'Trigeneration' box with an 'e' icon. From this box, three arrows branch out to 'Heat', 'Cooling', and 'Electricity' boxes, each with a corresponding icon. These three outputs then feed into a 'Consumer' box (factory icon). A separate arrow from the 'Trigeneration' box points to a 'CO₂' box with a flame icon, representing emissions.</p>
<p>PROJECT SCENARIO Switch from from carbon-intensive fossil fuel to a low-carbon-intensive fossil fuel in cogeneration/trigeneration system for production of power/heat and cooling.</p>	 <p>The diagram illustrates the project scenario. On the left, there are two 'Fossil fuel' boxes. The top one has a flame icon and an 'H' superscript, representing low-carbon fuel. The bottom one has a flame icon and a 'C' superscript, representing carbon-intensive fuel, and is crossed out with a large 'X'. An arrow from the 'H' box points to a 'Trigeneration' box with an 'e' icon. From this box, three arrows branch out to 'Heat', 'Cooling', and 'Electricity' boxes, each with a corresponding icon. These three outputs then feed into a 'Consumer' box (factory icon). A separate arrow from the 'Trigeneration' box points to a 'CO₂' box with a flame icon, representing emissions.</p>

AMS-III.AN. Fossil fuel switch in existing manufacturing industries

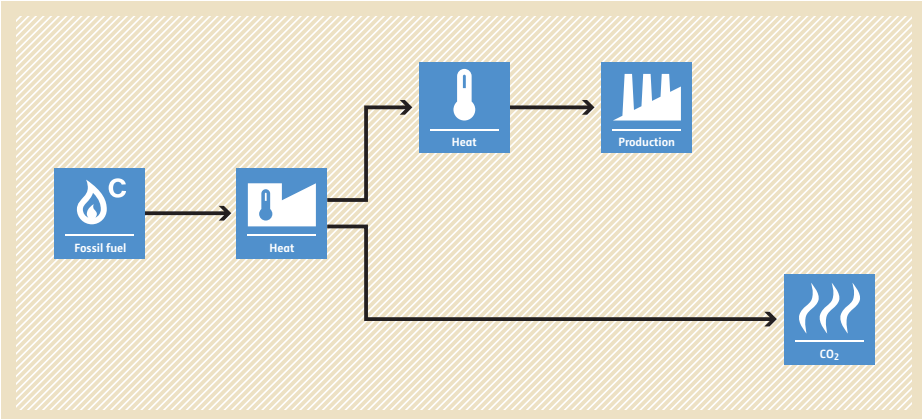
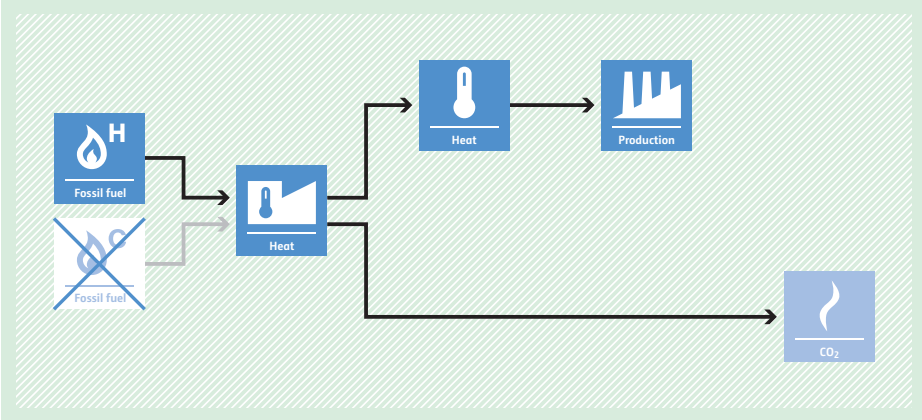
<p>Typical project(s)</p>	<p>Switching from a carbon-intensive fossil fuel to either a less-carbon-intensive fossil fuel or electricity with lower carbon intensity.</p>
<p>Type of GHG emissions mitigation action</p>	<ul style="list-style-type: none"> Fuel switch. <p>Switch to a fuel/energy source with a lower GHG intensity.</p>
<p>Important conditions under which the methodology is applicable</p>	<ul style="list-style-type: none"> The fuel switch occurs at a manufacturing facility with three years of historical data; The type of inputs and products are equivalent (outputs with same or better service level as compared to the baseline); The fuel switch at each element manufacturing process is from a single fossil fuel to less-carbon-intensive single fossil fuel or grid electricity; The fuel switch does not lead to a decrease in energy efficiency; Elemental process or other down stream/upstream processes do not change as a result of the fossil fuel switch.
<p>Important parameters</p>	<p>At validation:</p> <ul style="list-style-type: none"> Quantity of fossil fuel use or amount of the grid electricity consumed; Baseline raw material consumption and product output. <hr/> <p>Monitored:</p> <ul style="list-style-type: none"> Quantity of fossil fuel use or amount of the grid electricity consumed; The annual net project production of the element process or in cases where product output cannot be measured (e.g. hot/fused metal) annual net project raw material consumption should be monitored.
<p>BASELINE SCENARIO Continued use of a carbon-intensive fossil fuel for the heat generation in a manufacturing process.</p>	 <p>The diagram illustrates the baseline scenario. It starts with a box labeled 'Fossil fuel' with a 'C' (carbon) and a flame icon. An arrow points to a 'Heat' box with a thermometer icon. From this 'Heat' box, two arrows branch out: one points to another 'Heat' box with a thermometer icon, which then points to a 'Production' box with a factory icon; the other arrow points directly to a 'CO2' box with a flame icon.</p>
<p>PROJECT SCENARIO Switch of fuel to a less-carbon-intensive fuel or low-carbon grid electricity for the heat generation in a manufacturing process.</p>	 <p>The diagram illustrates the project scenario. It shows two 'Fossil fuel' boxes on the left. The top one has an 'H' (hydrogen) and a flame icon. The bottom one has a crossed-out 'C' and a flame icon. Arrows from both point to a central 'Heat' box with a thermometer icon. From this 'Heat' box, two arrows branch out: one points to another 'Heat' box with a thermometer icon, which then points to a 'Production' box with a factory icon; the other arrow points to a 'CO2' box with a flame icon. The 'CO2' box in this scenario is smaller than in the baseline scenario, indicating reduced emissions.</p>

AMS-III.AO. Methane recovery through controlled anaerobic digestion



<p>Typical project(s)</p>	<p>The project activity is the controlled biological treatment of biomass or other organic matters through anaerobic digestion in closed reactors equipped with biogas recovery and a combustion/flaring system.</p>
<p>Type of GHG emissions mitigation action</p>	<ul style="list-style-type: none"> • GHG formation avoidance. • Methane formation avoidance.
<p>Important conditions under which the methodology is applicable</p>	<ul style="list-style-type: none"> • If for one or more sources of substrates, it can not be demonstrated that the organic matter would otherwise been left to decay anaerobically, baseline emissions related to such organic matter shall be accounted for as zero; • Project activities treating animal manure as single source substrate shall apply AMS-III.D., similarly projects only treating wastewater and/or sludge generated in the wastewater treatment works shall apply AMS-III.H.; • The project activity does not recover or combust landfill gas from the disposal site (unlike AMS-III.G.), and does not undertake controlled combustion of the waste that is not treated biologically in a first step (unlike AMS-III.E.).
<p>Important parameters</p>	<p>At validation:</p> <ul style="list-style-type: none"> • The location and characteristics of the disposal site of the biomass used for digestion, in the baseline condition. <hr/> <p>Monitored:</p> <ul style="list-style-type: none"> • Quantity of solid waste (excluding manure); • Parameters for calculating methane emissions from physical leakage of methane; • Parameters related to emissions from electricity and/or fuel consumption.
<p>BASELINE SCENARIO Biomass or other organic matter would have otherwise been left to decay anaerobically.</p>	<pre> graph LR subgraph Inputs Waste[Waste] Biomass[Biomass] end Waste --> Disposal[Disposal] Biomass --> Disposal Disposal --> Biogas[Biogas] Biogas --> Release[Release] Release --> CH4[CH4] </pre>
<p>PROJECT SCENARIO Biological treatment of biomass or other organic matters through anaerobic digestion in closed reactors equipped with biogas recovery and a combustion/flaring system.</p>	<pre> graph LR subgraph Inputs Waste[Waste] Biomass[Biomass] end Waste --> Digester[Digester] Biomass --> Digester Digester --> Biogas[Biogas] Biogas --> Flaring[Flaring] Flaring --> Energy[Energy] Waste --> Disposal[Disposal] Biomass --> Disposal Disposal --> Gas[Gas] Gas --> Release[Release] Release --> CH4[CH4] style Disposal stroke-dasharray: 5 5 style Gas stroke-dasharray: 5 5 style Release stroke-dasharray: 5 5 style CH4 stroke-dasharray: 5 5 </pre>

AMS-III.AP. Transport energy efficiency activities using post – fit Idling Stop device

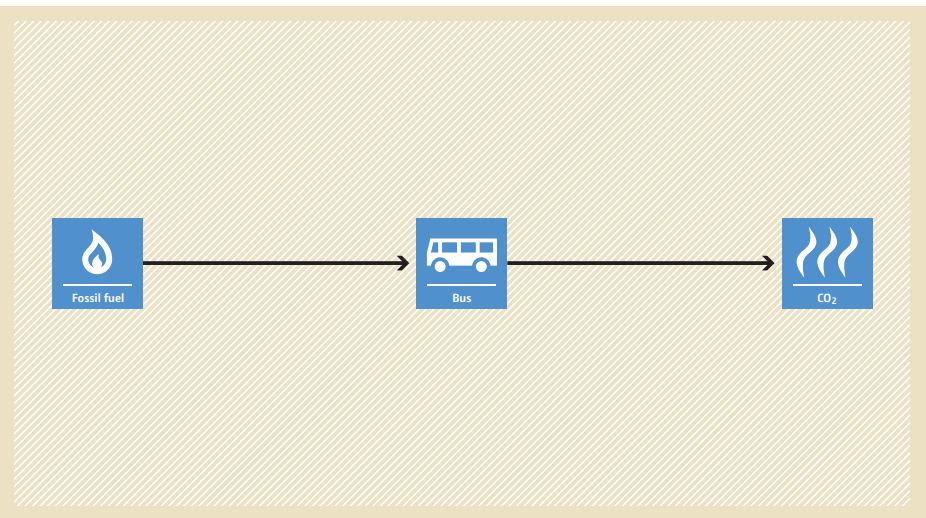
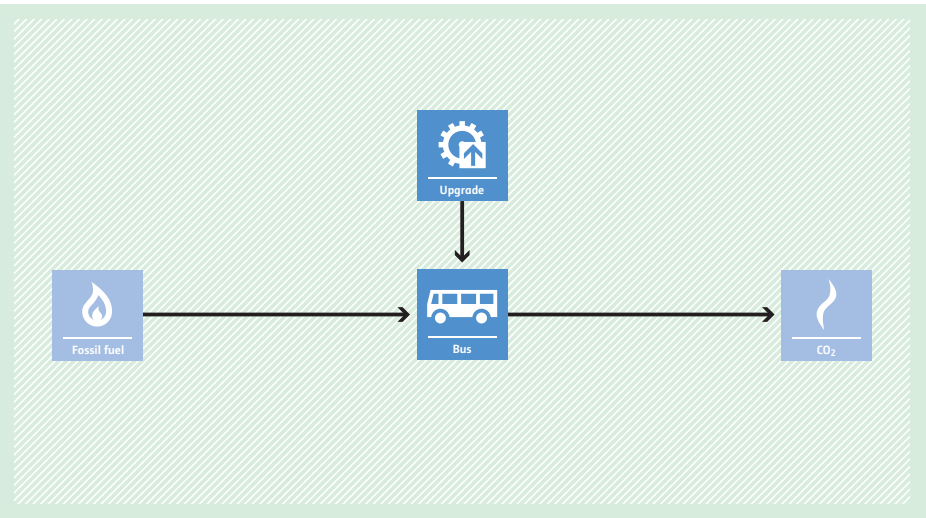
<p>Typical project(s)</p>	<p>Demand side activities associated with the installation of post-fit type Idling Stop devices in passenger vehicles used for public transport (e.g. buses).</p>
<p>Type of GHG emissions mitigation action</p>	<ul style="list-style-type: none"> • Energy Efficiency. <p>Reduction of fossil fuel use and corresponding emissions through energy efficiency improvements.</p>
<p>Important conditions under which the methodology is applicable</p>	<ul style="list-style-type: none"> • Vehicles used for public transportation; • Vehicles using gasoline or petrodiesel as fuel; • Vehicles in which it is possible to install post-fit Idling Stop device.
<p>Important parameters</p>	<p>Monitored:</p> <ul style="list-style-type: none"> • Cumulative Idling Period of all vehicles of type i in year y; • Total number of times of Idling Stop of vehicle i in the year y.
<p>BASELINE SCENARIO Vehicles used for public transportation continue idling.</p>	 <p>The baseline scenario flowchart is set against a yellow background with diagonal hatching. It shows a linear process: a blue box with a flame icon labeled 'Fossil fuel' has an arrow pointing to a blue box with a bus icon labeled 'Bus', which in turn has an arrow pointing to a blue box with a flame icon labeled 'CO2'.</p>
<p>PROJECT SCENARIO Vehicles used for public transportation using a post-fit type Idling Stop device that will turn off the vehicle engine and prevent idling.</p>	 <p>The project scenario flowchart is set against a green background with diagonal hatching. It shows a linear process: a blue box with a flame icon labeled 'Fossil fuel' has an arrow pointing to a blue box with a bus icon labeled 'Bus', which has an arrow pointing to a blue box with a flame icon labeled 'CO2'. Above the 'Bus' box is a blue box with a gear icon labeled 'Upgrade', with a downward arrow pointing to the 'Bus' box.</p>

AMS-III.AQ. Introduction of Bio-CNG in transportation applications

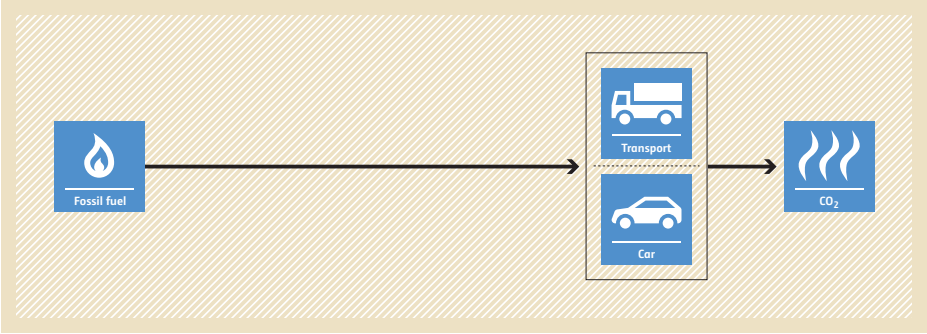
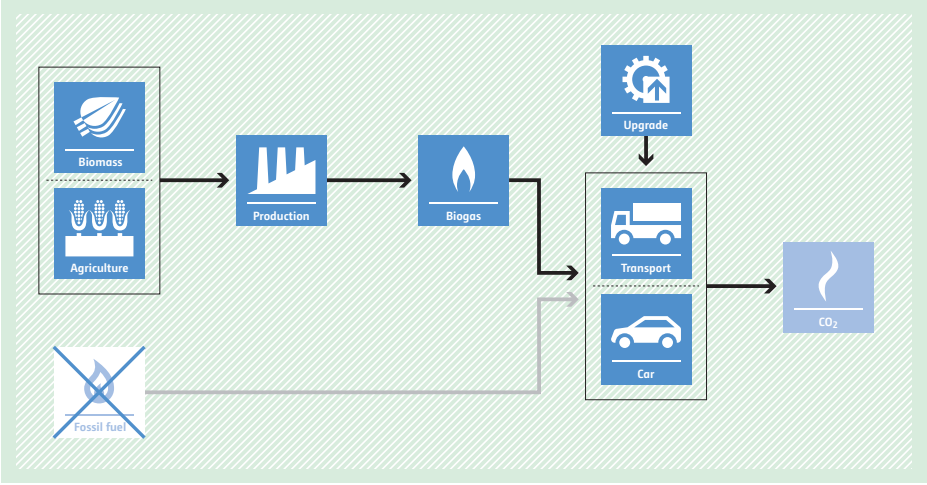
<p>Typical project(s)</p>	<p>Production of Biogenic Compressed Natural Gas (Bio-CNG) from renewable biomass and use in transportation applications. The Bio-CNG is derived from various sources such as biomass from dedicated plantations; waste water treatment; manure management; biomass residues.</p>
<p>Type of GHG emissions mitigation action</p>	<ul style="list-style-type: none"> • Renewable Energy. <p>Displacement of more-GHG-intensive fossil fuel for combustion in vehicles.</p>
<p>Important conditions under which the methodology is applicable</p>	<ul style="list-style-type: none"> • Bio-CNG is used in Compressed Natural Gas (CNG) vehicles, modified gasoline and/or diesel vehicles; • Methane content of the Bio-CNG meets relevant national regulations or a minimum of 96 per cent (by volume); • Conditions apply if the feedstock for production of the Bio-CNG is derived from dedicated plantation; • Export of Bio-CNG is not allowed; • Only the producer of the Bio-CNG can claim emission reductions.
<p>Important parameters</p>	<p>At validation:</p> <ul style="list-style-type: none"> • Determine fraction of gasoline (on mass basis) in the blend where national regulations require mandatory blending of the fuels with biofuels; • Amount of gasoline consumption in the baseline vehicles ex ante. <hr/> <p>Monitored:</p> <ul style="list-style-type: none"> • Amount of Bio-CNG produced/distributed/sold/consumed directly to retailers, filling stations; • Parameters for calculating methane emissions from physical leakage of methane; • Parameters for determining project emissions from renewable biomass cultivation.
<p>BASILINE SCENARIO Gasoline or CNG are used in the baseline vehicles.</p>	
<p>PROJECT SCENARIO Only Bio-CNG are used in the project vehicles.</p>	

AMS-III.AR. Substituting fossil fuel based lighting with LED/CFL lighting systems



<p>Typical project(s)</p>	<p>Activities that replace portable fossil fuel based lamps (e.g. wick-based kerosene lanterns) with battery-charged LED or CFL based lighting systems in residential and/or non-residential applications (e.g. ambient lights, task lights, portable lights).</p>
<p>Type of GHG emissions mitigation action</p>	<ul style="list-style-type: none"> • Renewable energy; • Energy efficiency. <p>Displacement of more-GHG-intensive service (lighting).</p>
<p>Important conditions under which the methodology is applicable</p>	<ul style="list-style-type: none"> • Project lamps whose batteries are charged using one of the following options: <ul style="list-style-type: none"> (a) Charged by a renewable energy system (e.g. a photovoltaic system or mechanical system such as a hand crank charger); (b) Charged by a standalone distributed generation system (e.g. a diesel generator set) or a mini-grid; (c) Charged by a grid that is connected to regional/national grid; • At a minimum, project lamps shall be certified by their manufacturer to have a rated average life of at least: <ul style="list-style-type: none"> – 5,000 hours for Option 1, as per paragraph 16 of the methodology; – 10,000 hours for Option 2, as per paragraph 17 of the methodology; • Project lamps shall have a minimum of one year warranty; • The replaced baseline lamps are those that directly consume fossil fuel.
<p>Important parameters</p>	<p>Monitored:</p> <ul style="list-style-type: none"> • Recording of project lamp distribution data; • In some cases ex post monitoring surveys to determine percentage of project lamps distributed to end users that are operating and in service in year y.
<p>BASELINE SCENARIO Use of fossil fuel based lamps.</p>	<p>The diagram shows a flow from 'Fossil fuel' (represented by a flame icon) to 'Lighting' (represented by a light bulb icon) and 'CO₂' (represented by a flame icon with wavy lines). This indicates that fossil fuel is used to power lighting, which results in CO₂ emissions.</p>
<p>PROJECT SCENARIO Use of LED/CFL based lighting systems.</p>	<p>The diagram shows a flow from 'Fossil fuel' (represented by a flame icon) to 'Renewable', 'Grid', and 'Power plant' (represented by icons of a lightning bolt, a plug, and a power plant respectively). These three sources then lead to 'Electricity' (represented by a lightning bolt icon). 'Electricity' leads to 'Lighting' (represented by a light bulb icon) and 'CO₂' (represented by a flame icon with wavy lines). Additionally, 'Lighting' leads to 'Upgrade' (represented by a gear icon), which then leads to 'Lighting'.</p>

AMS-III.AS. Switch from fossil fuel to biomass in existing manufacturing facilities for non-energy applications

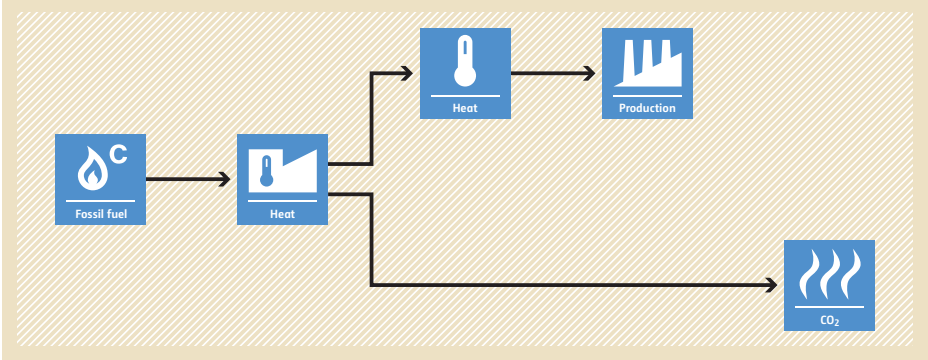
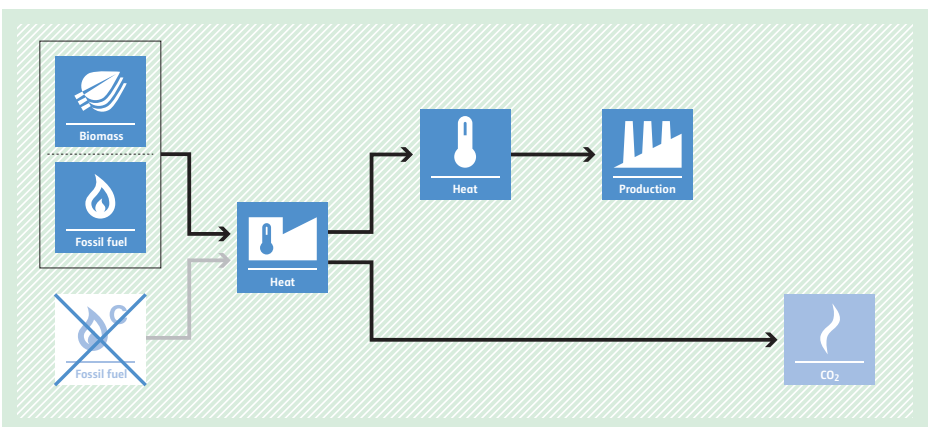
<p>Typical project(s)</p>	<p>Activities for fuel switching (complete or partial) from the use of carbon intensive energy source (or a mix of energy sources) of fossil origin to renewable biomass or a mix of renewable biomass and fossil fuel in existing manufacturing facilities (e.g. steel, ceramics, aluminium, lime, clinker production).</p>
<p>Type of GHG emissions mitigation action</p>	<ul style="list-style-type: none"> Fuel Switch. <p>Complete or partial switch from fossil fuel to biomass in non-energy applications.</p>
<p>Important conditions under which the methodology is applicable</p>	<ul style="list-style-type: none"> The switch occurs at a manufacturing facility with three years of historical data; The type of inputs and products are equivalent (outputs with same or better service level as compared to the baseline); Crops from renewable biomass origin are cultivated on an area which is classified as degraded or degrading as per the “Tool for the identification of degraded or degrading lands for consideration in implementing CDM A/R project activities” or on an area included in the project boundary of one or several registered A/R CDM project activities. Plantations established on peatlands are not eligible; Syngas derived from renewable energy source is eligible; Renewable biomass utilized by the project activity shall not be chemically processed.
<p>Important parameters</p>	<p>At validation:</p> <ul style="list-style-type: none"> Quantity of fossil fuel use; Baseline raw material consumption and product output. <p>Monitored:</p> <ul style="list-style-type: none"> The annual production output of the process or in cases where product output can not be measured annual net project raw materials consumption; Net quantity of biomass; Quantity of fossil fuel or amount of electricity consumed; Net calorific value/ Moisture content of biomass.
<p>BASELINE SCENARIO Use of fossil in manufacturing production process.</p>	 <p>The diagram illustrates the baseline scenario. It starts with a 'Fossil fuel' icon (flame with 'C'). An arrow points to a 'Heat' icon (thermometer). From this 'Heat' icon, two arrows branch out: one points to another 'Heat' icon (thermometer) which then points to a 'Production' icon (factory), and the other points directly to a 'CO2' icon (flames).</p>
<p>PROJECT SCENARIO Use of renewable biomass or mix of biomass/fossil fuel in manufacturing production process.</p>	 <p>The diagram illustrates the project scenario. On the left, there are three boxes: 'Biomass' (leaf icon), 'Fossil fuel' (flame icon), and a crossed-out 'Fossil fuel' icon (flame icon with a red 'X'). Arrows from the 'Biomass' and 'Fossil fuel' boxes point to a central 'Heat' icon (thermometer). From this central 'Heat' icon, two arrows branch out: one points to another 'Heat' icon (thermometer) which then points to a 'Production' icon (factory), and the other points to a 'CO2' icon (flames).</p>

AMS-III.AT. Transportation energy efficiency activities installing digital tachograph systems or similar devices to transport fleets

<p>Typical project(s)</p>	<p>Project activities that install digital tachograph systems or another device that monitors vehicle and driver performance and provides real-time feedback to drivers in freight vehicles and/or commercial passenger vehicles.</p>
<p>Type of GHG emissions mitigation action</p>	<ul style="list-style-type: none"> • Energy Efficiency. <p>Reduction of fossil fuel use and corresponding emissions through energy efficiency improvements.</p>
<p>Important conditions under which the methodology is applicable</p>	<ul style="list-style-type: none"> • This methodology applies to freight vehicle fleets and/or passenger vehicle fleets that are centrally controlled and managed by a single entity; • The project activity is unlikely to change the level of service of the vehicle fleet provided before the project activity; • The project activity does not involve a fuel switch in existing vehicles; • This methodology is not applicable to project activities in locations where the installation of the device is mandatory by law; • For freight vehicle fleets, project participants shall identify the traceable routes along which the vehicles operate, the characteristics of those routes, the level of service on each route, the vehicles that are in use on each traceable route before and after project implementation.
<p>Important parameters</p>	<p>Monitored:</p> <ul style="list-style-type: none"> • Total distance travelled by each vehicle; • The vehicles are identified based on the age, characteristics and load capacity and availability of historical data; • Annual average distance of transportation per tonne of freight by each project vehicle; • Consumption of fuel by vehicle; • Total annual goods transported by each project vehicle; • Annual monitoring to check if devices have become a mandatory practice, or that highly-enforced anti-idling policies or legislation have been put into place; • Monitoring to ensure that all device and feedback systems including fuel flow sensors (meters) are operating correctly and have not been disabled.
<p>BASELINE SCENARIO Fossil fuel consumption due to inefficient driving.</p>	<p>The diagram shows a linear flow from left to right. On the left is a blue square icon with a white flame and the text 'Fossil fuel'. An arrow points to a central box containing two icons: a white truck on the left and a white bus on the right, with the labels 'Transport' and 'Bus' respectively. Another arrow points from this central box to a blue square icon on the right with three white flames and the text 'CO₂'.</p>
<p>PROJECT SCENARIO A digital tachograph system or similar device reduces fossil fuel consumption in vehicles by providing to the driver feedback against inefficient driving, and thus encouraging efficient driver behaviour which results in improved vehicle fuel efficiency.</p>	<p>The diagram shows a linear flow from left to right. On the left is a blue square icon with a white flame and the text 'Fossil fuel'. An arrow points to a central box containing two icons: a white truck on the left and a white bus on the right, with the labels 'Transport' and 'Bus' respectively. Another arrow points from this central box to a blue square icon on the right with three white flames and the text 'CO₂'. Above the central box is a blue square icon with a white gear and the text 'Upgrade'. An arrow points from the 'Upgrade' icon down to the central box.</p>

AMS-III.AU. Methane emission reduction by adjusted water management practice in rice cultivation



<p>Typical project(s)</p>	<p>The following project activities are included:</p> <ol style="list-style-type: none"> Rice farms that change the water regime during the cultivation period from continuously to intermittent flooded conditions and/or a shortened period of flooded conditions; Alternate wetting and drying method and aerobic rice cultivation methods; and Rice farms that change their rice cultivation practice from transplanted to direct seeded rice.
<p>Type of GHG emissions mitigation action</p>	<ul style="list-style-type: none"> GHG emission avoidance. <p>Reduced anaerobic decomposition of organic matter in rice cropping soils.</p>
<p>Important conditions under which the methodology is applicable</p>	<ul style="list-style-type: none"> Rice cultivation in the project area is predominantly characterized by irrigated, flooded fields for an extended period of time during the growing season; The project rice fields are equipped with controlled irrigation and drainage facilities; The project activity does not lead to a decrease in rice yield. Likewise, it does not require the farm to switch to a cultivar that has not been grown before; Training and technical support during the cropping season is part of the project activity; The introduced cultivation practice, including the specific cultivation elements, technologies and use of crop protection products, is not subject to any local regulatory restrictions; If not using the default value approach, project participants shall have access to infrastructure to measure CH₄ emissions from reference fields using closed chamber method and laboratory analysis.
<p>Important parameters</p>	<p>Monitored:</p> <ul style="list-style-type: none"> Baseline emission factor and project emission factor (kgCH₄/ha per season), or the parameters specified in the default value approach; Aggregated project area; Monitoring of farmers' compliance with project cultivation practice.
<p>BASELINE SCENARIO Generation of methane due to anaerobic decomposition of organic matter in rice cropping soils.</p>	<pre> graph LR A[Rice field] --> B[Release] B --> C[CH4] </pre>
<p>PROJECT SCENARIO Methane emission avoidance, for example, by changing the water regime during the cultivation period from continuously to intermittent flooded conditions and/or a shortened period of flooded conditions.</p>	<pre> graph TD Upgrade[Upgrade] --> Management[Management] Management --> RiceField[Rice field] RiceField --> Release[Release] Release --> CH4[CH4] </pre>

AMS-III.AV. Low greenhouse gas emitting safe drinking water production systems



<p>Typical project(s)</p>	<p>Project activities that introduce low GHG emitting water purification systems to provide safe drinking water and displace water boiling using non-renewable biomass or fossil fuels. Water kiosks that treat water using one or more of the following technologies: chlorination, combined flocculant/disinfection powders and solar disinfection are also eligible.</p>
<p>Type of GHG emissions mitigation action</p>	<p>Displacement of a more-GHG-intensive output.</p>
<p>Important conditions under which the methodology is applicable</p>	<ul style="list-style-type: none"> • Prior to the implementation of the project activity, a public distribution network supplying safe drinking water to the project boundary does not exist; • The application of the project technology/equipment shall achieve compliance either with: (i) at a minimum the performance target as per “Evaluating household water treatment options: Health based targets and microbiological performance specifications” (WHO, 2011); or (ii) an applicable national standard or guideline; • In cases where the life span of the water treatment technologies is shorter than the crediting period of the project activity, there shall be documented measures in place to ensure that end users have access to replacement purification systems of comparable quality.
<p>Important parameters</p>	<p>Monitored:</p> <ul style="list-style-type: none"> • Checking of appliances to ensure that they are still operating or are replaced by an equivalent; • Quantity of purified water; • Annual check if a safe drinking water public distribution network is installed; • Number of persons supplied with purified water; • Safe drinking water quality; • Total electricity and fossil fuel consumption by the project activity.

BASELINE SCENARIO

Fossil fuel/non-renewable biomass consumption for water boiling as a mean for water purification.

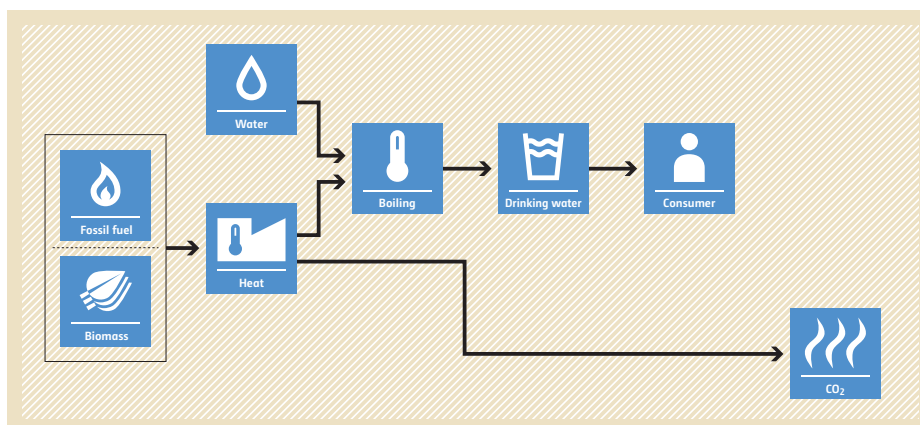

PROJECT SCENARIO

Low greenhouse gas emitting water purification system ensures safe drinking water supply.

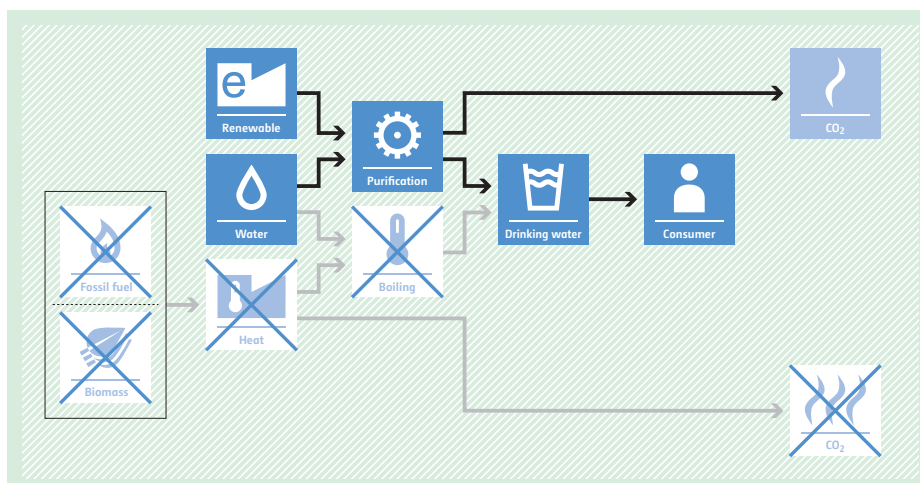

AMS-III.AW. Electrification of rural communities through grid extension



<p>Typical project(s)</p>	<p>Rural communities which were not connected to a grid prior to project implementation are supplied with electricity by connection to a national or regional grid.</p>
<p>Type of GHG emissions mitigation action</p>	<ul style="list-style-type: none"> • Renewable energy. <p>Displacement of electricity that would be provided by more-GHG-intensive means.</p>
<p>Important conditions under which the methodology is applicable</p>	<ul style="list-style-type: none"> • End-users are not connected to a grid prior to the project; • Existing renewable mini-grid electricity is not displaced by the project; • Emission reductions can only be claimed, if the renewable electricity generation in the grid is greater than or equal to 99% of the total electricity generation.
<p>Important parameters</p>	<p>At validation:</p> <ul style="list-style-type: none"> • In case of a diesel-based mini-grid, fuel consumption and electricity generation of mini-grid connected plants (the most recent data from the last three years). <p>Monitored:</p> <ul style="list-style-type: none"> • Net amount of renewable electricity delivered to the project area.
<p>BASELINE SCENARIO In the absence of the project activity, the end users would have used diesel generator to generate electricity.</p>	<pre> graph LR FF[Fossil fuel] --> PP[Power plant] PP --> E1[Electricity] PP --> CO2[CO2] E1 --> C[Consumer] </pre>
<p>PROJECT SCENARIO End users are supplied electricity with a grid with high shares of renewable generation (i.e. 99%).</p>	<pre> graph TD subgraph Project_Scenario R[Renewable] --> E2[Electricity] E2 --> C[Consumer] end subgraph Baseline_Crossed_Out FF[Fossil fuel] --> PP[Power plant] PP --> E1[Electricity] PP --> CO2[CO2] E1 --> C end E2 --> E1 </pre>

AMS-III.AX. Methane oxidation layer (MOL) for solid waste disposal sites

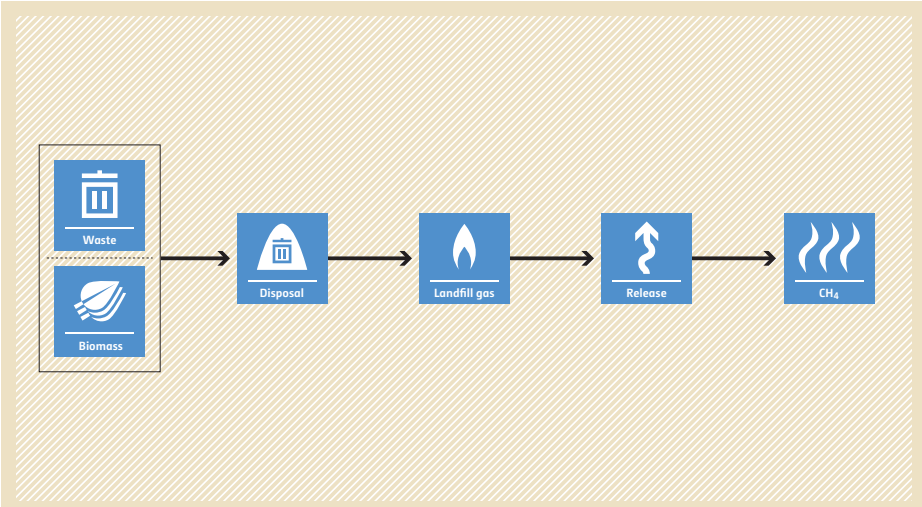
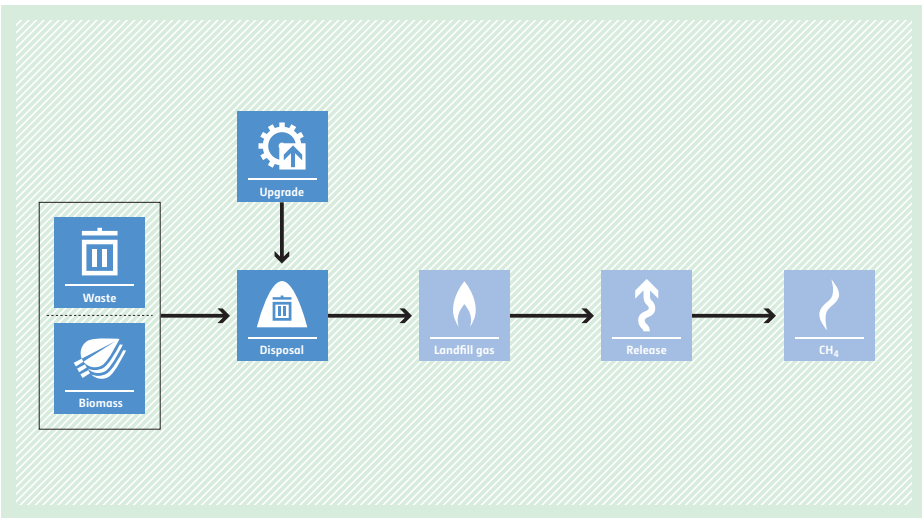
<p>Typical project(s)</p>	<p>Project activities involving the construction of a methane oxidation layer (MOL) on top of a municipal solid waste disposal site (SWDS) to avoid the release of methane through biological oxidation in the MOL.</p>
<p>Type of GHG emissions mitigation action</p>	<ul style="list-style-type: none"> • GHG destruction. <p>Avoidance of methane emissions from solid waste disposal sites.</p>
<p>Important conditions under which the methodology is applicable</p>	<ul style="list-style-type: none"> • It is applicable where landfill gas collection and treatment is not applicable due to low concentration of landfill gas (less than $4 \text{ L CH}_4 \cdot \text{m}^{-2} \cdot \text{h}^{-1}$) or other reasons; • It is not applicable at SWDS with an active gas extraction system, or that are still receiving wastes for disposal or where a MOL is required by legal regulation.
<p>Important parameters</p>	<p>Monitored:</p> <ul style="list-style-type: none"> • Parameters related to methane oxidising material quality such as TOC, ammonium and nitrite have to be analyzed; • Parameters related to MOL construction properties, e.g. thickness of MOL and gas distribution layer/balancing layer during application; • Parameters related to methane oxidation performance, e.g. measured volume fraction of methane in the middle of the distribution layer.
<p>BASELINE SCENARIO Biomass and other organic matter in waste are left to decay and methane is emitted into the atmosphere.</p>	 <p>The diagram illustrates the baseline scenario. It starts with a box containing 'Waste' (represented by a trash can icon) and 'Biomass' (represented by a leaf icon). An arrow points from this box to a 'Disposal' icon (a trash can with a lid). From 'Disposal', an arrow points to 'Landfill gas' (represented by a flame icon). Another arrow points to 'Release' (represented by a wavy arrow icon), and a final arrow points to 'CH₄' (represented by a flame icon).</p>
<p>PROJECT SCENARIO Methane that would have been released is oxidized in the MOL.</p>	 <p>The diagram illustrates the project scenario. It starts with a box containing 'Waste' (represented by a trash can icon) and 'Biomass' (represented by a leaf icon). An arrow points from this box to a 'Disposal' icon (a trash can with a lid). Above the 'Disposal' icon is an 'Upgrade' icon (a gear with an upward arrow). An arrow points from 'Upgrade' down to 'Disposal'. From 'Disposal', an arrow points to 'Landfill gas' (represented by a flame icon). Another arrow points to 'Release' (represented by a wavy arrow icon), and a final arrow points to 'CH₄' (represented by a flame icon).</p>

AMS-III.AY. Introduction of LNG buses to existing and new bus routes

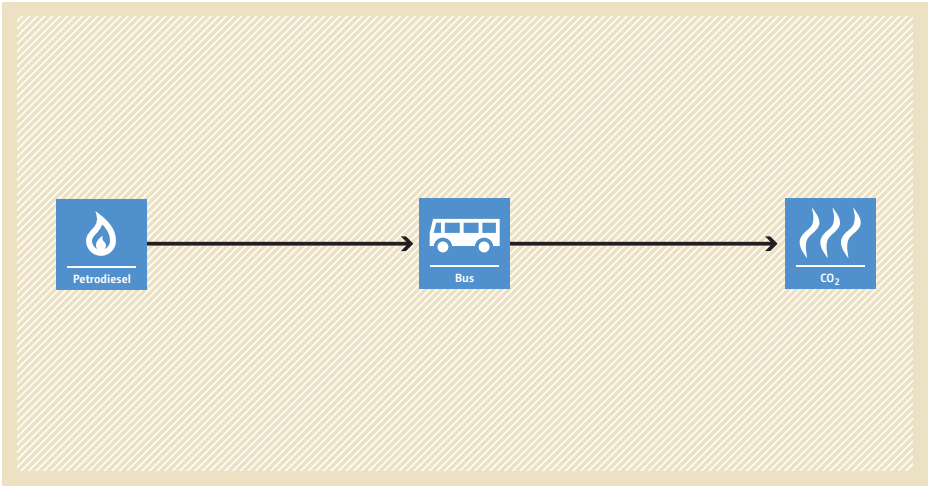
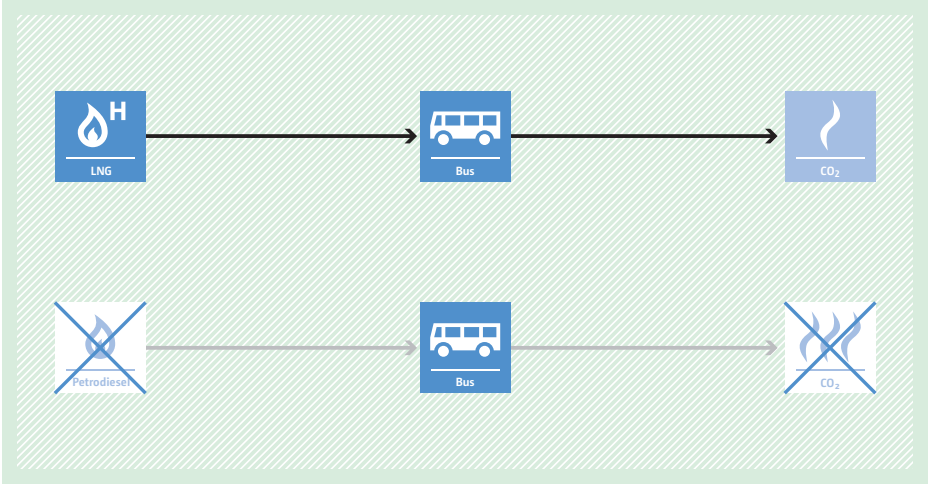
<p>Typical project(s)</p>	<p>Introduction and operation of new LNG buses for passengers transportation to existing and new routes.</p>
<p>Type of GHG emissions mitigation action</p>	<ul style="list-style-type: none"> • Fuel switch. • Displacement of more-GHG-intensive vehicles.
<p>Important conditions under which the methodology is applicable</p>	<ul style="list-style-type: none"> • The existing and new routes are fixed; • On each route only one type of bus and fuel are used; • For the new routes it should be demonstrated that these new routes have been planned prior to the start date of the project activity and serviced by fossil fuel busses; • The project and baseline frequency of operation of the buses should be the same; • The project and baseline buses should be with comparable passengers capacity and power rating.
<p>Important parameters</p>	<p>At validation:</p> <ul style="list-style-type: none"> • Baseline fuel data (NCV and emission factor). <p>Monitored:</p> <ul style="list-style-type: none"> • Specific fuel consumption of baseline buses; • Total annual distance travelled by baseline buses; • Fuel consumption of the project buses.
<p>BASELINE SCENARIO Buses use diesel or comparable fossil fuel.</p>	 <p>The diagram illustrates the baseline scenario within a yellow hatched box. It shows a linear flow: a blue square icon with a flame and the word 'Petrodiesel' below it, followed by a right-pointing arrow to a blue square icon with a bus and the word 'Bus' below it, followed by another right-pointing arrow to a blue square icon with three wavy lines and 'CO₂' below it.</p>
<p>PROJECT SCENARIO Buses use LNG only.</p>	 <p>The diagram illustrates the project scenario within a green hatched box. It shows two parallel flows. The top flow is active: a blue square icon with a flame, an 'H' above it, and 'LNG' below it, followed by a right-pointing arrow to a blue square icon with a bus and 'Bus' below it, followed by another right-pointing arrow to a blue square icon with a flame and 'CO₂' below it. The bottom flow is crossed out with a large blue 'X': a blue square icon with a flame and 'Petrodiesel' below it, followed by a right-pointing arrow to a blue square icon with a bus and 'Bus' below it, followed by another right-pointing arrow to a blue square icon with a flame and 'CO₂' below it.</p>



AMS-III.BA. Recovery and recycling of materials from E-waste

<p>Typical project(s)</p>	<p>Collection and recycling activities of E-waste, comprising of end-of-life, discarded, surplus, obsolete, or damaged electrical and electronic equipment, performed in dedicated facilities with the aim of recovering materials such as ferrous metals, non-ferrous metals, plastics.</p>
<p>Type of GHG emissions mitigation action</p>	<ul style="list-style-type: none"> • Energy efficiency. <p>Reduction of production of metals and plastics from virgin materials, thus reducing related energy consumption.</p>
<p>Important conditions under which the methodology is applicable</p>	<ul style="list-style-type: none"> • This methodology applies to the recycling of the following materials: aluminium, steel, copper, gold, silver, palladium, tin, lead; Acrylonitrile Butadiene Styrene (ABS), High Impact Polystyrene (HIPS); • Materials recycled under the project activity are recovered only from end-of-life E-wastes; • The properties of the metals and plastics produced from E-waste recycling are the same as those of the metals and plastics from virgin materials; • The ex ante baseline recycling rate of E-waste is equal to or smaller than 20% of the total amount of E-waste. Where the baseline recycling rates exceed 20%, the project activity has to lead to significantly higher rates of recycling in the region/country.
<p>Important parameters</p>	<p>Monitored:</p> <ul style="list-style-type: none"> • Quantity of material recycled and sent to a processing or manufacturing facility; • Electricity and fossil fuel consumption at the recycling facility; • Evidence that the materials recycled under the project activity are recovered only from end-of-life E-wastes.

BASELINE SCENARIO
Metals and plastics are produced from virgin raw materials resulting in high energy consumption.

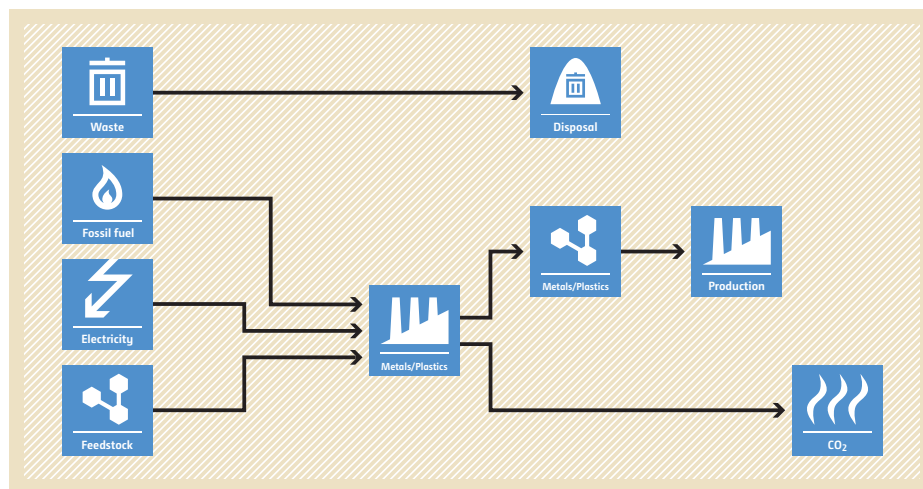

PROJECT SCENARIO
Production of metals and plastics based on virgin raw material is reduced. Use of recycled material results in less energy consumption.

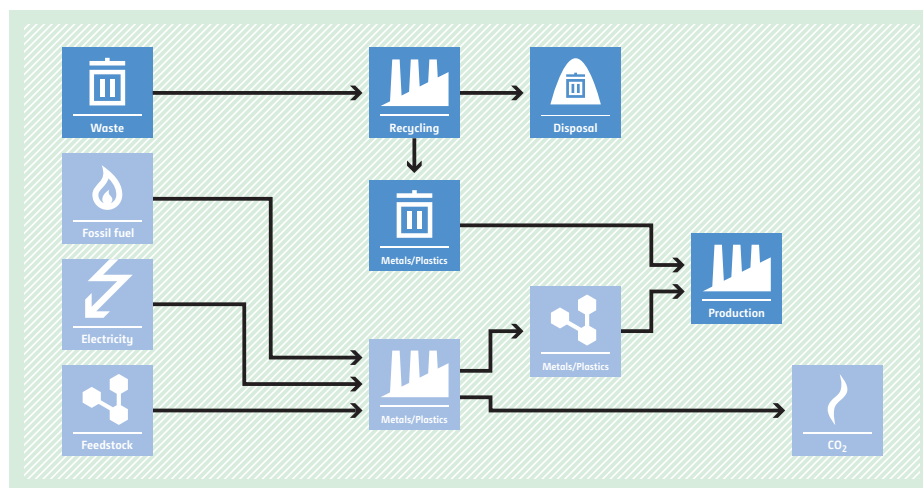

AMS-III.BB. Electrification of communities through grid extension or construction of new mini-grids



Typical project(s)	The project activity supplies electricity to consumers who, prior to project implementation, were not connected to a national/regional grid and were supplied by a high-carbon-intensive mini-grid or stand-alone power generators. Also fuel-based lighting systems might have been used before the project implementation.
Type of GHG emissions mitigation action	<ul style="list-style-type: none"> Displacement of more-GHG-intensive output. Low-carbon-intensive grid/mini-grid electricity displaces high-carbon-intensive electricity or lighting services.
Important conditions under which the methodology is applicable	<ul style="list-style-type: none"> Limited to communities with no access to a national or regional grid; At least 75% of the end users (by number) shall be households.
Important parameters	At validation: <ul style="list-style-type: none"> The physical location of each consumer and the anticipated connected load and usage hours of each consumer. Monitored: <ul style="list-style-type: none"> Metering of total electricity delivered to consumers (e.g. at a substation); Metering of electricity consumption of all non-household end users (e.g. commercial consumers, SMMEs, public institutions, street lighting, irrigation pumps) and household end-users expected to consume more than 1000 kWh/year.

BASELINE SCENARIO

In the absence of the project activity, the end users would have used fossil fuel based lighting, stand-alone diesel electricity generators for appliances other than lighting (e.g. TV) or would have been supplied by fossil-fuel-based mini-grid.

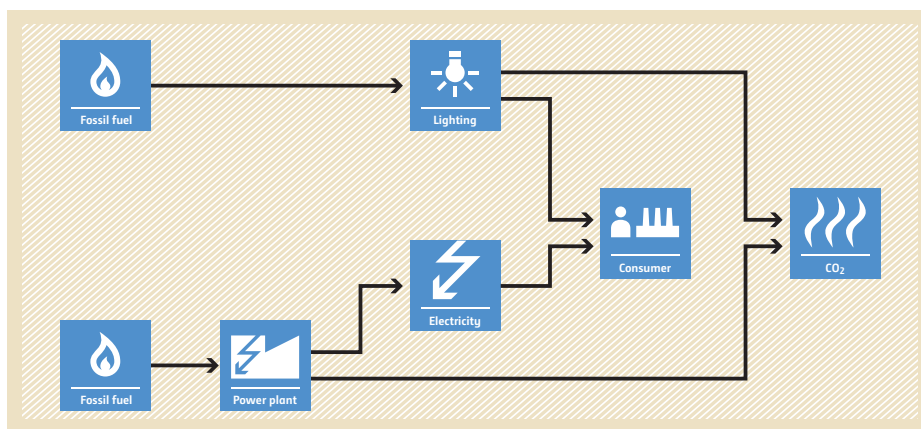

PROJECT SCENARIO

Consumers are supplied with electricity by connection to a national or regional or mini-grid or by a new mini-grid.

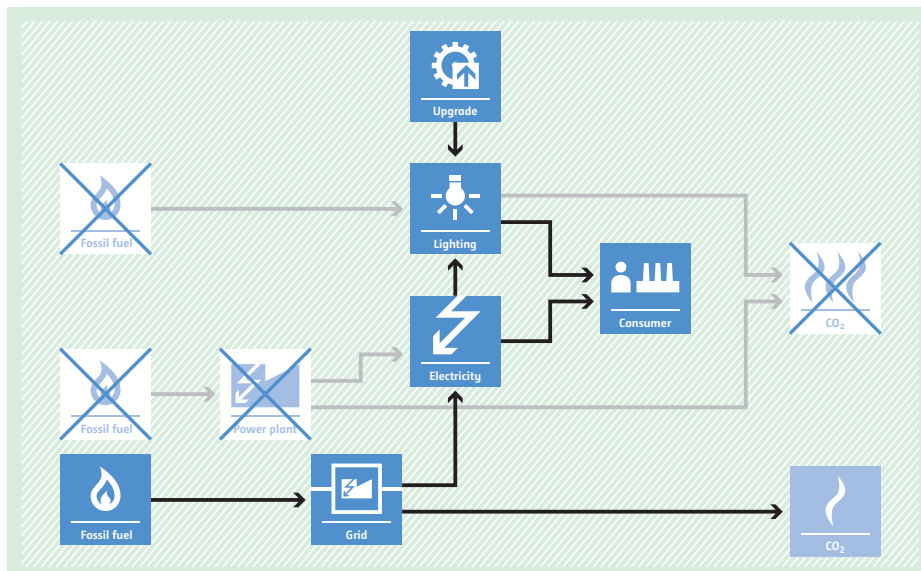

AMS-III.BC. Emission reductions through improved efficiency of vehicle fleets

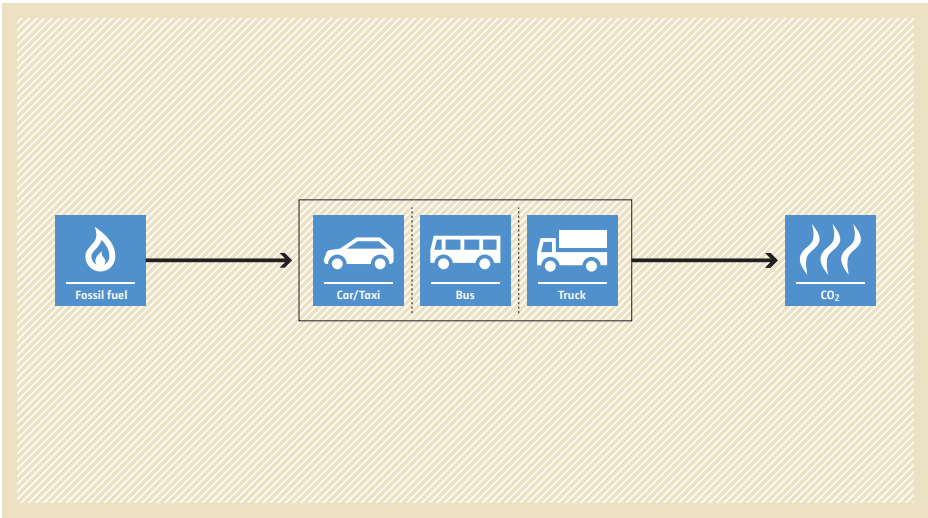
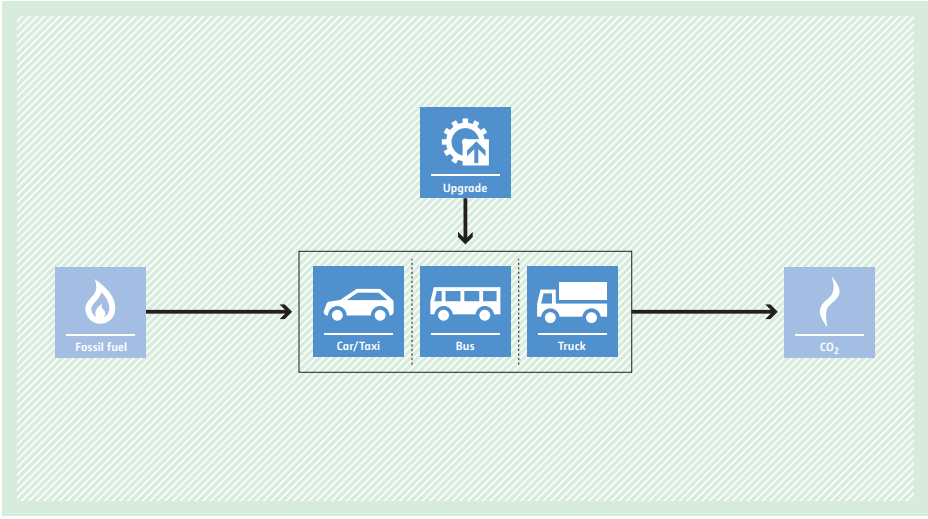
<p>Typical project(s)</p>	<p>Improvement of the operational efficiency of vehicle fleets (e.g. fleets of trucks, buses, cars, taxis or motorized tricycles).</p>
<p>Type of GHG emissions mitigation action</p>	<ul style="list-style-type: none"> • Energy efficiency. <p>Fossil fuels savings through various equipment and/or activity improvement.</p>
<p>Important conditions under which the methodology is applicable</p>	<ul style="list-style-type: none"> • Implementation of idling stop device, eco-drive systems, tire-rolling resistance improvements, air-conditioning system improvements, use of low viscosity oils, aerodynamic drag reduction measures and/or transmission improvements, retrofits that improve engine efficiency; • Vehicle fleets shall be centrally owned and managed by a single entity and driven by contractors or employees of the central entity; • Technologies employed to improve combustion efficiency without improvements in engine efficiency are not applicable.
<p>Important parameters</p>	<p>Monitored:</p> <ul style="list-style-type: none"> • Specific baseline and project fuel consumption of the vehicle categories; • Average gross weight per vehicle of the vehicle categories; • Activity levels (travelled distance) of the project vehicle categories.
<p>BASELINE SCENARIO Fossil fuel consumption due to inefficient operation of vehicle fleets.</p>	 <p>The diagram illustrates the baseline scenario. On the left, a blue square icon with a flame is labeled 'Fossil fuel'. An arrow points from this icon to a central box containing three smaller blue square icons: a car labeled 'Car/Taxi', a bus labeled 'Bus', and a truck labeled 'Truck'. From this central box, another arrow points to a blue square icon on the right with three wavy lines, labeled 'CO₂'.</p>
<p>PROJECT SCENARIO Reduced fossil fuel consumption due to improved operational efficiency of vehicle fleets.</p>	 <p>The diagram illustrates the project scenario. It follows the same flow as the baseline scenario, starting with a 'Fossil fuel' icon and ending with a 'CO₂' icon. However, an additional blue square icon with a gear and an upward arrow, labeled 'Upgrade', is positioned above the central vehicle icons box. An arrow points from the 'Upgrade' icon down to the vehicle icons box, indicating that the upgrade process leads to improved efficiency and reduced emissions.</p>

AMS-III.BD. GHG emission reductions due to supply of molten metal instead of ingots for aluminium castings

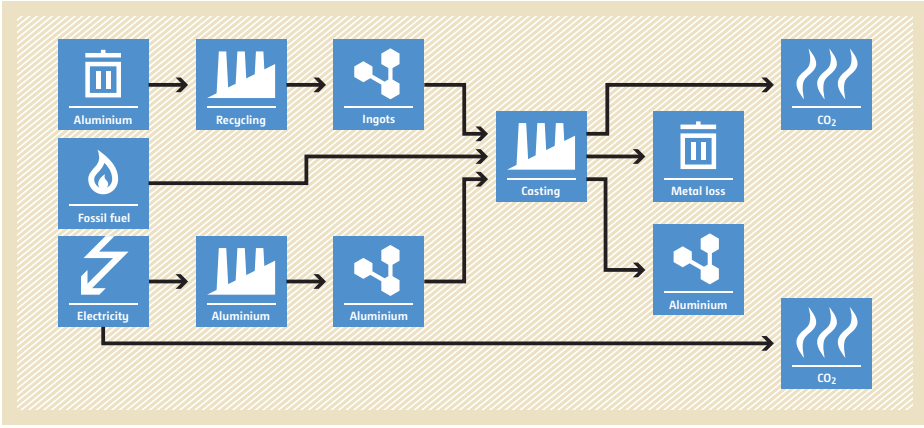
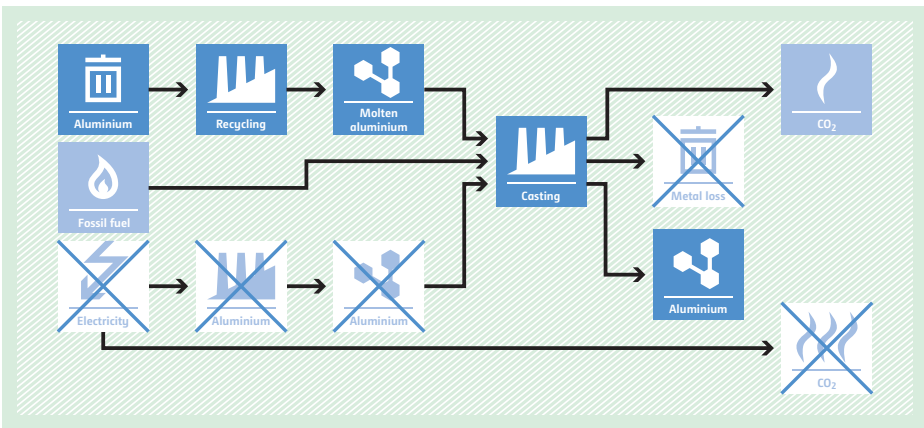
<p>Typical project(s)</p>	<p>Construction and operation of scrap aluminium recycling units to directly supply molten aluminium instead of ingots to casting units, thereby reducing GHG emissions on the account of avoided use of energy to re-melt aluminium ingots and produce equivalent quantity of primary aluminium due to metal loss during re-melting of aluminium ingots.</p>
<p>Type of GHG emissions mitigation action</p>	<ul style="list-style-type: none"> • Feedstock switch; • Energy efficiency. <p>Displacement of a more-GHG-intensive output. Savings of energy due to direct supply of molten aluminium to casting units.</p>
<p>Important conditions under which the methodology is applicable</p>	<ul style="list-style-type: none"> • For project implemented in existing facilities, both recycling and casting units have a history of operation for at least three years prior to the start of the project activity; • Mandatory investment analysis for baseline determination if the project size is greater than 600 t CO₂ per year per casting unit; • Hot metal transport between the recycling facility and casting unit is undertaken in closed ladle; • Contractual agreement between the recycling facility and casting unit to avoid double counting of emission reductions; • Production outputs in baseline and project scenarios remain homogenous and within a range of ±10% with no change in installed capacity.
<p>Important parameters</p>	<p>At validation:</p> <ul style="list-style-type: none"> • Percentage loss of aluminium due to oxidation during the process of re-melting of ingots; • Efficiency of the furnace at the casting unit to which the molten metal is being supplied. <p>Monitored:</p> <ul style="list-style-type: none"> • Quantity of molten aluminium supplied; • Energy consumption associated to the transportation of molten metal.
<p>BASELINE SCENARIO</p> <p>Supply of aluminium ingots to the casting units from the aluminium metal recycling facilities. The casting units melt the ingots using fossil fuel and/or electricity before being moulded. During the melting of ingots, some aluminium metal is lost because of oxidation.</p>	 <p>The diagram illustrates the baseline scenario for aluminium casting. It shows a flow from left to right. On the left, there are three input boxes: 'Aluminium' (with a recycling symbol), 'Fossil fuel' (with a flame symbol), and 'Electricity' (with a lightning bolt symbol). Arrows from 'Aluminium' and 'Fossil fuel' lead to a 'Recycling' box (factory icon). An arrow from 'Electricity' leads to an 'Aluminium' box (factory icon). From 'Recycling', an arrow leads to an 'Ingots' box (hexagonal symbol). From the 'Aluminium' box, an arrow leads to another 'Aluminium' box (hexagonal symbol). Both 'Ingots' and the second 'Aluminium' box have arrows pointing to a 'Casting' box (factory icon). From the 'Casting' box, an arrow leads to a 'Metal loss' box (trash can icon), and another arrow leads to an 'Aluminium' box (hexagonal symbol). From 'Metal loss', an arrow leads to a 'CO₂' box (flame symbol). From the 'Aluminium' box, an arrow leads to another 'CO₂' box (flame symbol).</p>
<p>PROJECT SCENARIO</p> <p>Direct supply of molten aluminium from aluminium recycling units avoids the remelting of ingots in the casting units and thus reduces the energy use for the production of aluminium.</p>	 <p>The diagram illustrates the project scenario for aluminium casting. It shows a flow from left to right. On the left, there are two input boxes: 'Aluminium' (with a recycling symbol) and 'Fossil fuel' (with a flame symbol). Arrows from both lead to a 'Recycling' box (factory icon). From 'Recycling', an arrow leads to a 'Molten aluminium' box (hexagonal symbol). From the 'Fossil fuel' box, an arrow leads to a 'Casting' box (factory icon). From 'Molten aluminium', an arrow leads to the 'Casting' box. From the 'Casting' box, an arrow leads to a 'Metal loss' box (trash can icon), and another arrow leads to an 'Aluminium' box (hexagonal symbol). From 'Metal loss', an arrow leads to a 'CO₂' box (flame symbol). From the 'Aluminium' box, an arrow leads to another 'CO₂' box (flame symbol). In this scenario, the 'Electricity' input box, the 'Aluminium' box (factory icon), the 'Aluminium' box (hexagonal symbol), and the 'CO₂' box (flame symbol) at the bottom right are all crossed out with a large 'X', indicating they are avoided.</p>

AMS-III.BE. Avoidance of methane and nitrous oxide emissions from sugarcane pre-harvest open burning through mulching

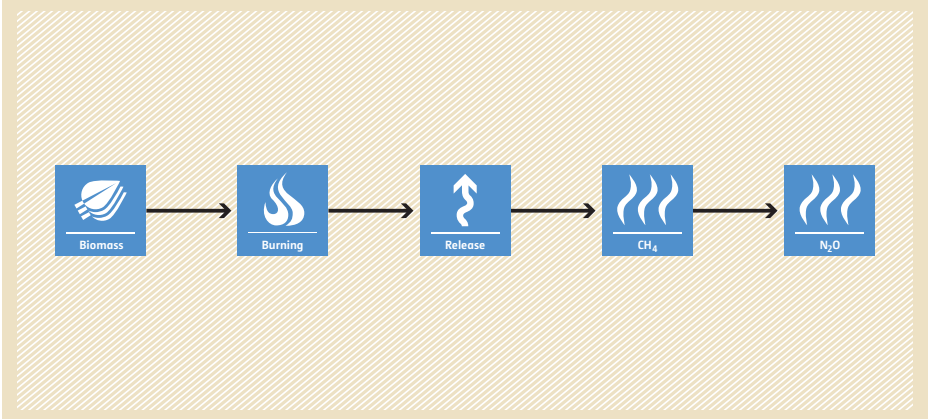
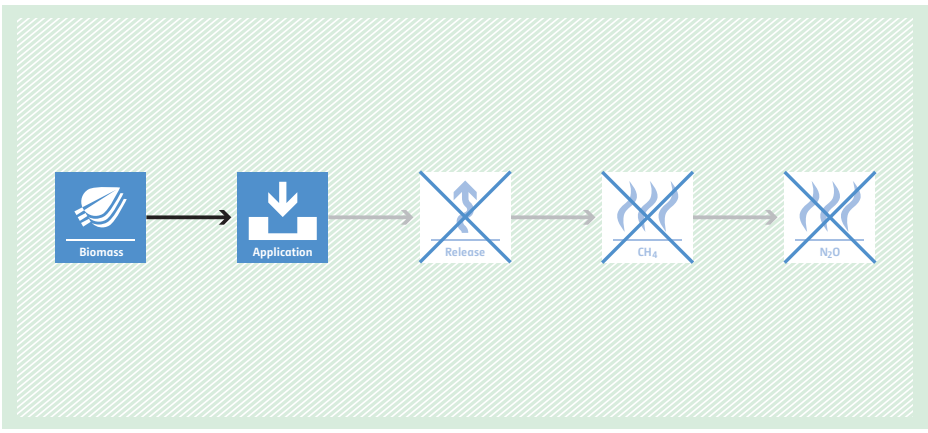
Typical project(s)	Aerobic treatment of biomass from sugarcane harvesting by mulching.
Type of GHG emissions mitigation action	<ul style="list-style-type: none"> • GHG emission avoidance. Methane and nitrous oxide emissions avoidance by replacing pre-harvest open burning of sugarcane biomass with mulching of sugarcane biomass.
Important conditions under which the methodology is applicable	<ul style="list-style-type: none"> • It shall be established ex ante at the beginning of the project activity that open burning is not legally prohibited in the project region and it is the common practice; • It can be demonstrated that the participating farms have been cultivating only sugarcane or, have been cultivating sugarcane as well as other crops on the same land in the immediate three years prior to the starting date of the project activity; • If sugarcane biomass is stored before the mulching process, the storage time shall be less than 7 days.
Important parameters	<p>At validation:</p> <ul style="list-style-type: none"> • Cultivation of sugarcane in the farms; • Open burning status before the implementation of project activity. <hr/> <p>Monitored:</p> <ul style="list-style-type: none"> • Mulching process of sugarcane biomass residues; • Status of open burning after the project activity; • Sugarcane yield and raw sugar production.
BASELINE SCENARIO Sugarcane biomass residues are burnt in open fire.	 <p>The diagram illustrates the baseline scenario for sugarcane biomass residues. It consists of five sequential steps connected by arrows: 1. 'Biomass' (represented by a leaf icon), 2. 'Burning' (represented by a flame icon), 3. 'Release' (represented by an upward arrow icon), 4. 'CH₄' (represented by a flame icon), and 5. 'N₂O' (represented by a flame icon). The entire process is set against a light brown background with a diagonal line pattern.</p>
PROJECT SCENARIO Sugarcane biomass residues are collected and applied in the field by mulching.	 <p>The diagram illustrates the project scenario for sugarcane biomass residues. It consists of five sequential steps connected by arrows: 1. 'Biomass' (represented by a leaf icon), 2. 'Application' (represented by a downward arrow icon), 3. 'Release' (represented by an upward arrow icon with a blue 'X' over it), 4. 'CH₄' (represented by a flame icon with a blue 'X' over it), and 5. 'N₂O' (represented by a flame icon with a blue 'X' over it). The entire process is set against a light green background with a diagonal line pattern.</p>

AMS-III.BF. Reduction of N₂O emissions from use of Nitrogen Use Efficient (NUE) seeds that require less fertilizer application

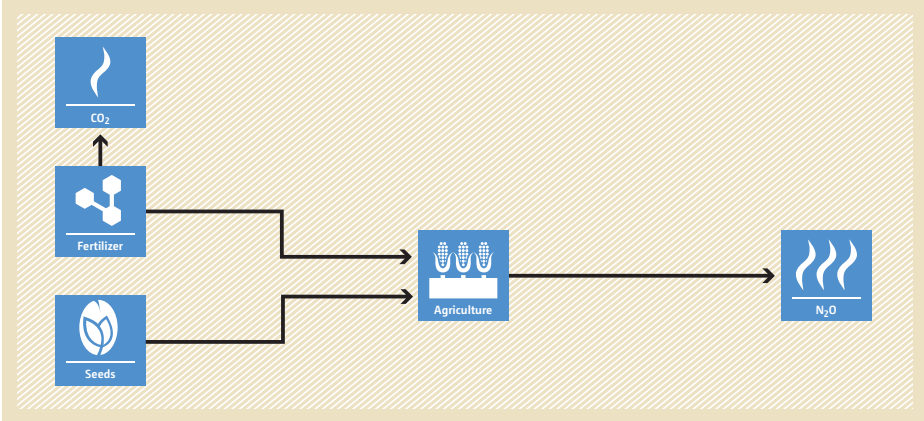
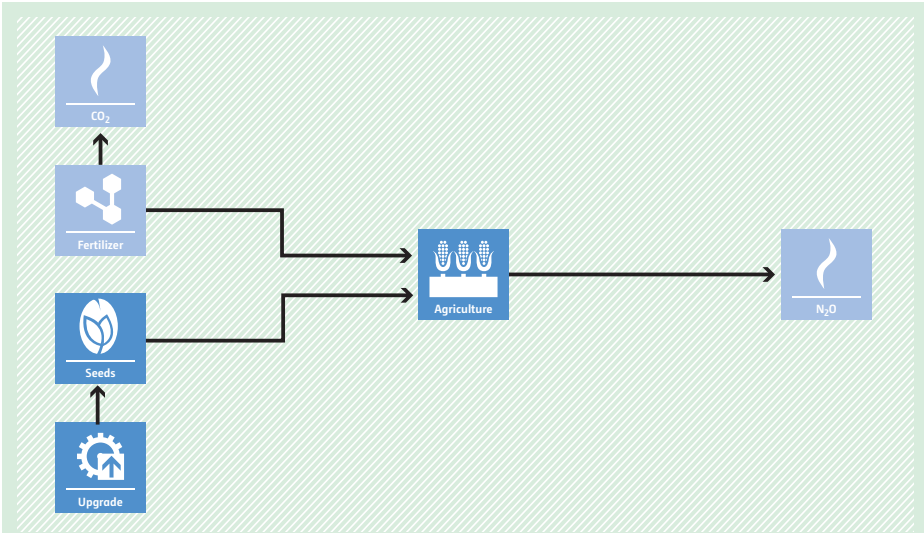
<p>Typical project(s)</p>	<p>Use of a genetically distinct type of seed for crops that will utilize nitrogen more efficiently.</p>
<p>Type of GHG emissions mitigation action</p>	<ul style="list-style-type: none"> • GHG emission avoidance. <p>Avoidance of N₂O emissions from agricultural activity by reducing the amount of fertilizer used by the crop.</p>
<p>Important conditions under which the methodology is applicable</p>	<ul style="list-style-type: none"> • The seeds have been genetically engineered to modify genes in nitrogen assimilation and metabolic pathways in ways that significantly increase the quantity of crop output per unit of nitrogen available for plant use; • The containers of NUE seed must be clearly marked as such and always remain segregated from other seed; • Technologies/measures where the savings in synthetic nitrogen fertilizer applications are attributable in total or in part to enhanced biological fixation (e.g. by rhizobia activity) are not applicable.
<p>Important parameters</p>	<p>At validation:</p> <ul style="list-style-type: none"> • Historic data for synthetic nitrogen fertilizer, crop yield, and management practices. <p>Monitored:</p> <ul style="list-style-type: none"> • Amount of crop produced by the project activity; • Cultivated area; • Total quantity of nitrogen fertilizers utilized by the farms/fields utilizing the baseline and project technology; • Area cultivation efficiency (productivity) in the project scenario.
<p>BASELINE SCENARIO Use of traditional seeds and nitrogen fertilizer rates, in order to achieve the same crop output as in the project scenario.</p>	 <p>The diagram illustrates the baseline scenario. It shows three input boxes on the left: 'CO₂' (with a flame icon), 'Fertilizer' (with a molecular structure icon), and 'Seeds' (with a leaf icon). Arrows from 'Fertilizer' and 'Seeds' point to a central 'Agriculture' box (with a field icon). An arrow from 'CO₂' also points to the 'Agriculture' box. From the 'Agriculture' box, an arrow points to an 'N₂O' box (with a flame icon).</p>
<p>PROJECT SCENARIO Use of NUE seeds and reduced nitrogen fertilizer rates, in order to achieve the same crop output as in the baseline scenario.</p>	 <p>The diagram illustrates the project scenario. It shows four input boxes on the left: 'Upgrade' (with a gear icon), 'Seeds' (with a leaf icon), 'Fertilizer' (with a molecular structure icon), and 'CO₂' (with a flame icon). Arrows from 'Upgrade' and 'Seeds' point to a central 'Agriculture' box (with a field icon). Arrows from 'Fertilizer' and 'CO₂' also point to the 'Agriculture' box. From the 'Agriculture' box, an arrow points to an 'N₂O' box (with a flame icon).</p>

AMS-III.BG. Emission reduction through sustainable charcoal production and consumption



<p>Typical project(s)</p>	<p>Project activities that displace the use of non-renewable biomass in the production of charcoal supplied to identified consumers.</p>
<p>Type of GHG emissions mitigation action</p>	<ul style="list-style-type: none"> • Fuel or feedstock switch; • Energy efficiency. <p>Displacement of more GHG intensive, non-renewable biomass fuelled applications by introducing more efficient technologies.</p>
<p>Important conditions under which the methodology is applicable</p>	<ul style="list-style-type: none"> • End users of charcoal shall be: (i) households; or (ii) small and medium enterprises (SME); or (iii) a group of households served by a charcoal market; • The project activity shall introduce efficient charcoal production technologies, including micro gasifier stoves.
<p>Important parameters</p>	<p>At validation:</p> <ul style="list-style-type: none"> • Kiln used in the baseline scenario; • Feedstock used in the baseline kiln. <p>Monitored:</p> <ul style="list-style-type: none"> • Produced quantity of charcoal; • Energy consumption; • End-user of charcoal produced in project activities.
<p>BASELINE SCENARIO Production of charcoal by using non-renewable and renewable biomass.</p>	<p>The baseline scenario flowchart shows a process starting with two inputs: 'Non-renewable' biomass (represented by a leaf icon with a slash) and 'Renewable' biomass (represented by a leaf icon). Both inputs feed into a 'Charcoal' production stage (represented by a factory icon). From the 'Charcoal' stage, the process continues to a 'Heat' stage (represented by a thermometer icon), which then leads to a 'Consumer' stage (represented by a person icon). Below the 'Charcoal' stage, there is a 'CH₄' emission stage (represented by a flame icon). Below the 'Heat' stage, there is a 'CO₂' emission stage (represented by a flame icon). The 'Non-renewable' input is crossed out with a blue 'X'.</p>
<p>PROJECT SCENARIO Production of charcoal by using renewable biomass in a more efficient way.</p>	<p>The project scenario flowchart shows a process starting with 'Renewable' biomass (represented by a leaf icon) and an 'Upgrade' stage (represented by a gear icon). The 'Renewable' biomass feeds into a 'Charcoal' production stage (represented by a factory icon). The 'Upgrade' stage also feeds into the 'Charcoal' stage. From the 'Charcoal' stage, the process continues to a 'Heat' stage (represented by a thermometer icon), which then leads to a 'Consumer' stage (represented by a person icon). Below the 'Charcoal' stage, there is a 'CH₄' emission stage (represented by a flame icon). Below the 'Heat' stage, there is a 'CO₂' emission stage (represented by a flame icon with a blue 'X' over it). The 'Non-renewable' input is crossed out with a blue 'X'.</p>

AMS-III.BH. Displacement of production of brick and cement by manufacture and installation of gypsum concrete wall panels

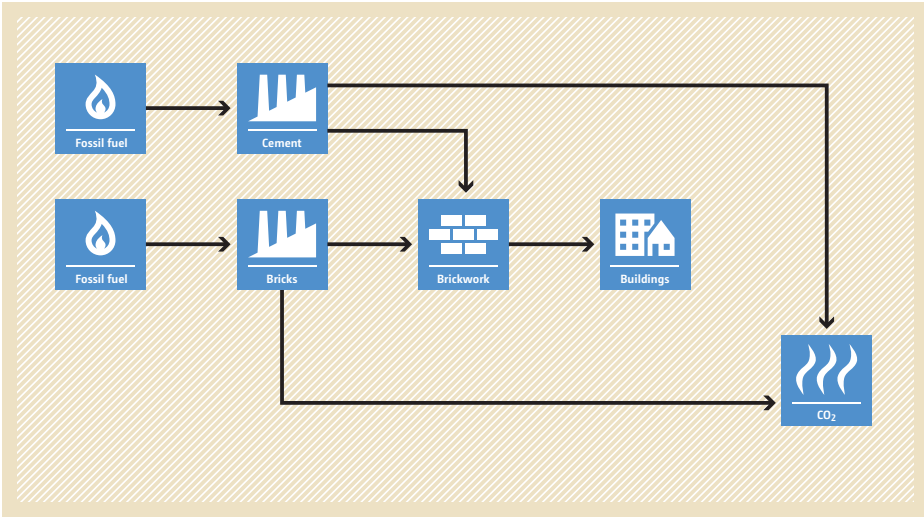
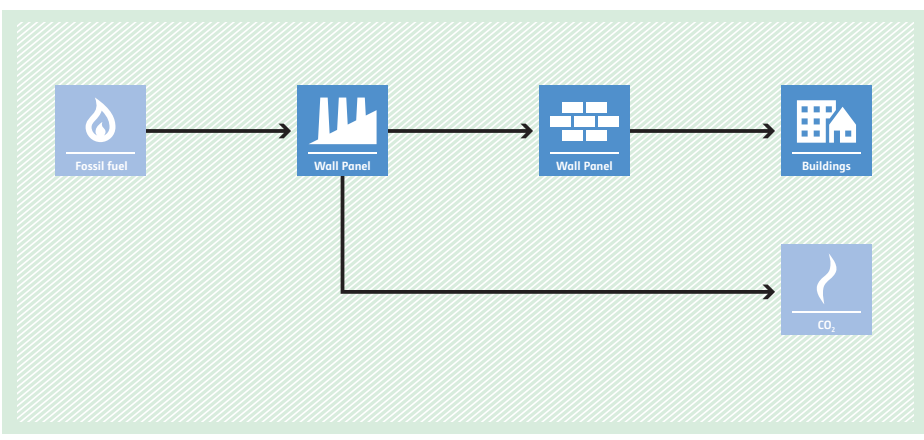
<p>Typical project(s)</p>	<p>Replacement of brickwork with less GHG intensive gypsum concrete wall panels in construction of walls.</p>
<p>Type of GHG emissions mitigation action</p>	<ul style="list-style-type: none"> • GHG emission avoidance. <p>Displacement of a more GHG intensive construction material.</p>
<p>Important conditions under which the methodology is applicable</p>	<ul style="list-style-type: none"> • Domestically produced gypsum concrete wall panel shall be used for applications such as non load-bearing walls, load-bearing walls and fencing (compound/security walls) in greenfield building projects or expansion of existing buildings; • The proportion of imported cement is less than 10% of the cement produced within the host country where the projects are hosted; • A declaration from the panel buyers and or final users stating that they would not claim CERs for the panels used by them is required to avoid double counting.
<p>Important parameters</p>	<p>At validation:</p> <ul style="list-style-type: none"> • Type of applications of gypsum concrete wall panels; • Gypsum concrete composition; • Number of bricks and quantity of cement used per square meter of wall in the baseline scenario. <p>Monitored:</p> <ul style="list-style-type: none"> • Area of wall panel sold and used by final consumers; • Quantity of raw material consumed in the production of gypsum concrete wall panel. • End-user of charcoal produced in project activities.
<p>BASELINE SCENARIO Use of traditional construction material such as brick and cement in brickwork for construction of walls.</p>	 <pre> graph LR FF1[Fossil fuel] --> C[Cement] FF2[Fossil fuel] --> B[Bricks] C --> BW[Brickwork] B --> BW BW --> BU[Buildings] C --> CO2[CO2] B --> CO2 </pre>
<p>PROJECT SCENARIO Use of gypsum concrete wall panel for construction of walls which will provide same or better service and performance level when compared with base scenario.</p>	 <pre> graph LR FF[Fossil fuel] --> WP[Wall Panel] WP --> BU[Buildings] WP --> CO2[CO2] </pre>

AMS-III.BI. Flare gas recovery in gas treating facilities

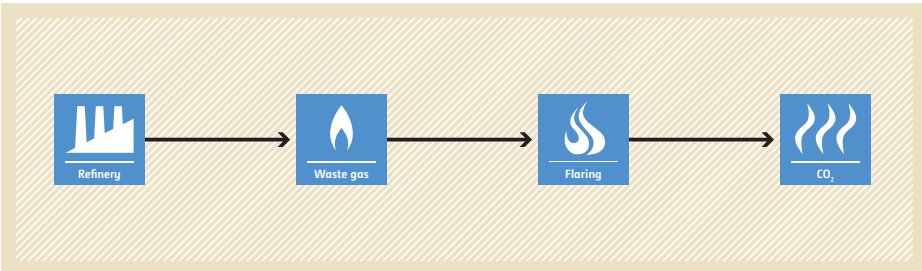
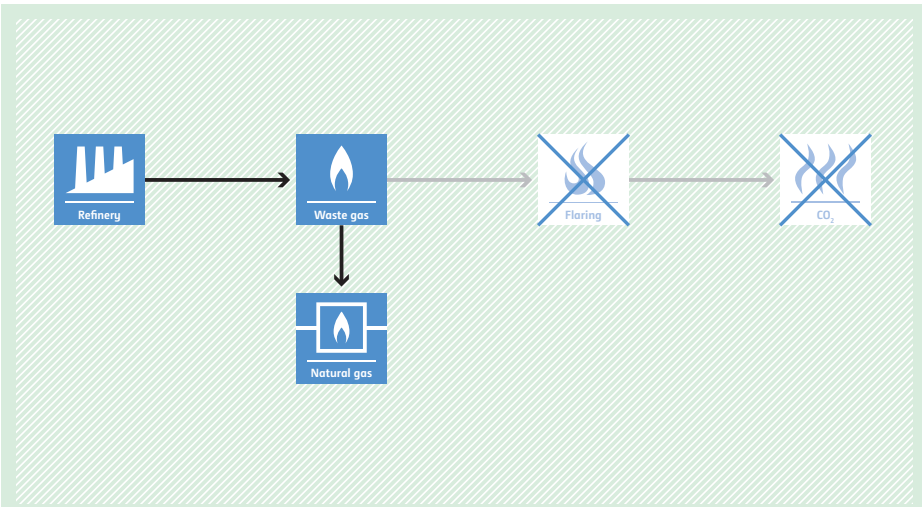
<p>Typical project(s)</p>	<p>Off-spec gas is captured and injected into a gas sales line for transportation to the market after cleaning/processing and compressing in dedicated project facilities.</p>
<p>Type of GHG emissions mitigation action</p>	<ul style="list-style-type: none"> • Energy efficiency. <p>Recovering the waste off-spec gas and utilizing for useful applications.</p>
<p>Important conditions under which the methodology is applicable</p>	<ul style="list-style-type: none"> • Off-spec gas from gas processing facilities (GPF), used by the project activity, totally or partially was flared (not vented) for at least three years, prior to the start date of the project; • Recovered off-spec gas in the project activity should be captured, compressed, and cleaned/processed in the GPF before being injected into a gas sales line for transportation to the market; • Off-spec gas volume, energy content and composition are measurable; • There shall not be any addition of fuel gas or dry gas into the off-spec gas pipeline between the point of recovery and the point where it is fed into the GPF.
<p>Important parameters</p>	<p>At validation:</p> <ul style="list-style-type: none"> • Quantity and composition of off-spec gases. <p>Monitored:</p> <ul style="list-style-type: none"> • Quantity and composition of off-spec gases utilised; • Electricity and fuel used.
<p>BASELINE SCENARIO The off-spec gas is flared.</p>	 <p>The diagram shows a linear process flow on a yellow background. It starts with a 'Refinery' icon (factory), followed by an arrow to a 'Waste gas' icon (flame), another arrow to a 'Flaring' icon (flame), and a final arrow to a 'CO₂' icon (flames).</p>
<p>PROJECT SCENARIO Off-spec gas is captured and injected into a gas sales line for transportation to the market after cleaning/processing and compressing in dedicated project facilities.</p>	 <p>The diagram shows a process flow on a green background. It starts with a 'Refinery' icon (factory), followed by an arrow to a 'Waste gas' icon (flame). From 'Waste gas', a downward arrow points to a 'Natural gas' icon (flame). From 'Waste gas', a horizontal arrow points to a 'Flaring' icon (flame) which has a blue 'X' over it. From 'Flaring', a horizontal arrow points to a 'CO₂' icon (flames) which also has a blue 'X' over it.</p>

AMS-III.BJ. Destruction of hazardous waste using plasma technology including energy recovery

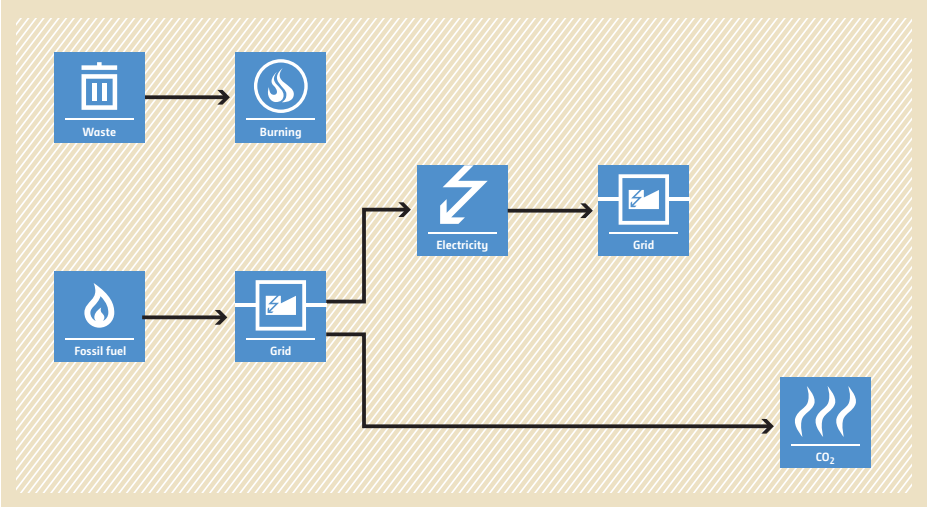
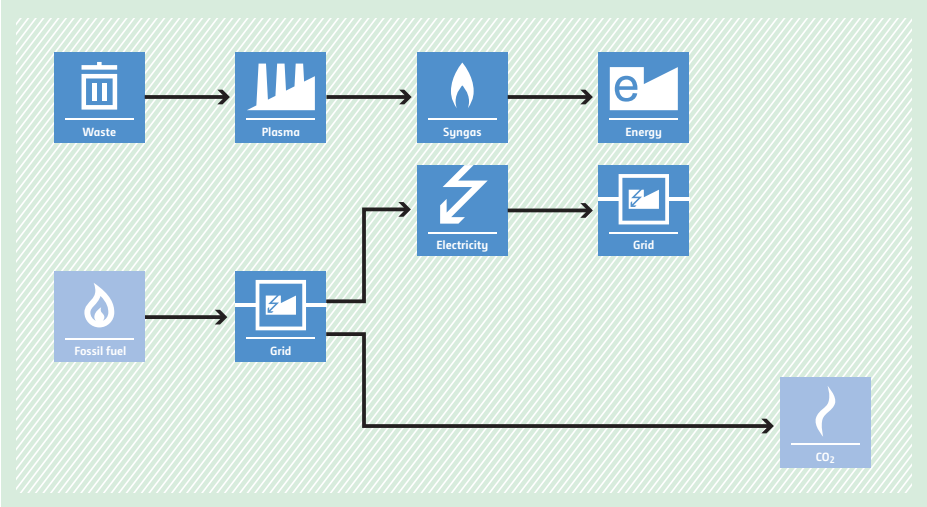
<p>Typical project(s)</p>	<p>Gasification of hazardous waste, using plasma technology, to produce syngas. Electricity and heat are generated by the syngas produced.</p>
<p>Type of GHG emissions mitigation action</p>	<ul style="list-style-type: none"> • Renewable energy. <p>The syngas produced by the project activity is used as a renewable energy source.</p>
<p>Important conditions under which the methodology is applicable</p>	<ul style="list-style-type: none"> • The project incinerates only hazardous waste; • The regulation requires incineration of hazardous waste; • No existing hazardous waste incinerators produce heat or electricity.
<p>Important parameters</p>	<p>At validation:</p> <ul style="list-style-type: none"> • Historical waste incineration; • Fuel and electricity consumption for historical waste incineration. <hr/> <p>Monitored:</p> <ul style="list-style-type: none"> • Project waste incineration; • Project fuel and electricity consumption; • Compliance rate with incineration regulations; • Heat and/or electricity generated.
<p>BASELINE SCENARIO Hazardous waste is incinerated without energy generation.</p>	 <p>The baseline scenario flowchart shows 'Waste' being processed through 'Burning'. 'Fossil fuel' is used to generate 'Electricity', which is then sent to the 'Grid'. 'CO₂' emissions are shown as a result of the process.</p>
<p>PROJECT SCENARIO Hazardous waste is gasified using plasma technology with energy generation.</p>	 <p>The project scenario flowchart shows 'Waste' being processed through 'Plasma' technology to produce 'Syngas'. 'Syngas' is then used to generate 'Energy' and 'Electricity'. 'Fossil fuel' is used to generate 'Electricity', which is then sent to the 'Grid'. 'CO₂' emissions are shown as a result of the process.</p>

AMS-III.BK. Strategic feed supplementation in smallholder dairy sector to increase productivity

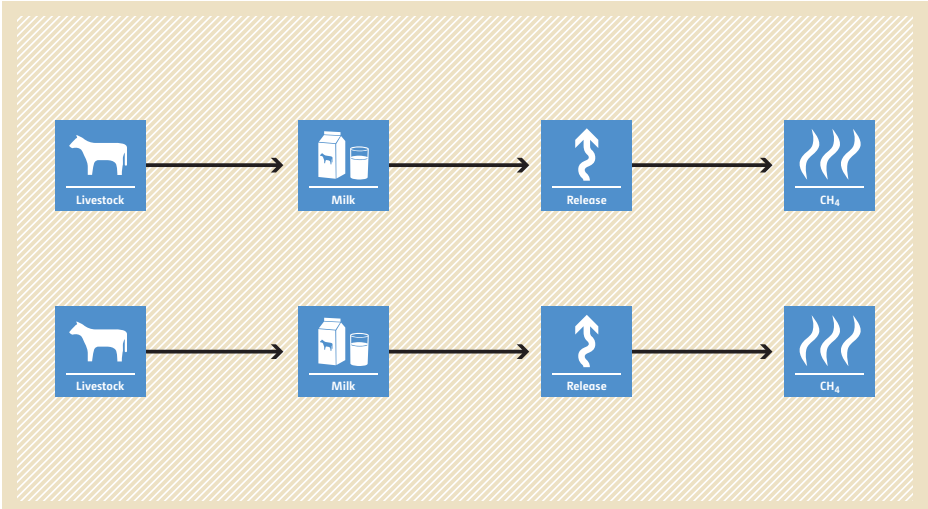
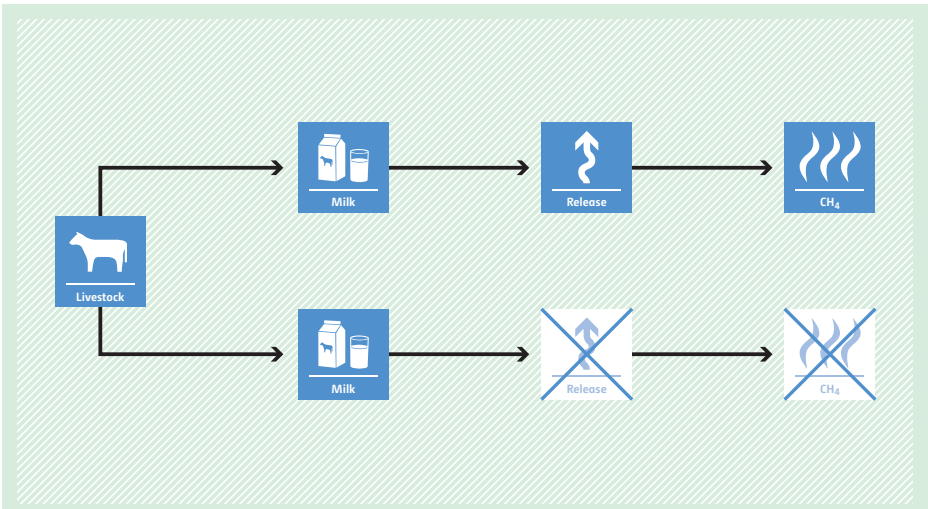
Typical project(s)	Provision of strategic supplementation to large ruminants (e.g. cows), which reduces the level of methane emissions per unit of milk produced.
Type of GHG emissions mitigation action	<ul style="list-style-type: none"> Methane avoidance and displacement of a more-GHG-intensive output. Methane emission avoidance from large ruminants due to improved productivity by using strategic supplementation to improve digestibility.
Important conditions under which the methodology is applicable	<ul style="list-style-type: none"> The population of lactating animals maintained in the participating smallholders shall be equal or less than 100; The gross energy (GE) content of the supplement consumed does not exceed 10% of the total GE of the basal ration.
Important parameters	At validation: <ul style="list-style-type: none"> Number of lactating animals in the farm and their milk production. Monitored: <ul style="list-style-type: none"> Number of lactating animals in the farm and their milk production; Amount of supplement used for the lactating animals.
BASELINE SCENARIO High specific methane emission per unit of milk production due to the poor nutritional conditions of lactating animals in the baseline.	
PROJECT SCENARIO Reduced specific methane emission per unit of milk production due to improved nutritional conditions of lactating animals in the project	

A photograph of a forest with tall, thin trees and a body of water reflecting the scene. The trees are mostly bare, suggesting a dry season or a specific type of forest. The water is calm, creating clear reflections of the trees and the sky. The sky is a deep blue, and the overall lighting is soft, possibly from the golden hour.

CDM Methodology Booklet

Chapter IV

METHODOLOGIES FOR AFFORESTATION AND REFORESTATION (A/R) CDM PROJECT ACTIVITIES

4.1. INTRODUCTION TO METHODOLOGIES FOR A/R CDM PROJECT ACTIVITIES

The following conditions and information are relevant for all A/R methodologies and are applicable in addition to the conditions listed in the methodology summaries:

- Vegetation cover on the land eligible for project activities must have been below the forest threshold⁷ on 31 December 1989. This needs to be proven (e.g. using satellite image or participatory rural appraisal (PRA));
- No tree vegetation is expected to emerge without human intervention to form a forest on the project land;
- Project start date must be January 1, 2000 or later.
- In absence of the project activity, carbon stocks of the carbon pools not considered in the project activity are expected to decrease or increase less relative to the project scenario.

A/R CDM project activities result in t-CERs and l-CERs.

A/R methodologies can be distinguished as large-scale and small-scale. Small-scale A/R methodologies provide simplified approaches for project design and monitoring. Small-scale A/R project activities must fulfil the following conditions:

- (1) Net anthropogenic GHG removals by sinks must be less than 16,000 tons of CO₂ per year; and
- (2) The project activities must be developed or implemented by low-income communities and individuals as determined by the host Party.

If an A/R CDM project activity does not meet these criteria an A/R large-scale methodology has to be applied.

⁷ The host country determines the forest definition which lies within the following thresholds: A single minimum tree crown cover value between 10 and 30%; and a single minimum land area value between 0.05 and 1 hectare; and a single minimum tree height value between 2 and 5 metres

4.2. METHODOLOGICAL TOOLS FOR A/R CDM PROJECT ACTIVITIES

A short description of methodological tools relevant to A/R methodologies can be found below.

COMBINED TOOL TO IDENTIFY THE BASELINE SCENARIO AND DEMONSTRATE ADDITIONALITY IN A/R CDM PROJECT ACTIVITIES

This tool provides a step-wise approach to identify the baseline scenario and simultaneously demonstrate additionality. These steps include:

- Step 0* Preliminary screening based on the starting date of the A/R project activity;
- Step 1* Identification of alternative land use scenarios;
- Step 2* Barrier analysis;
- Step 3* Investment analysis (if needed);
- Step 4* Identification of the baseline scenario;
- Step 5* Common practice analysis.

This tool is not applicable to small-scale project activities.

CALCULATION OF THE NUMBER OF SAMPLE PLOTS FOR MEASUREMENTS WITHIN A/R CDM PROJECT ACTIVITIES

This tool can be used for calculation of number of sample plots required for estimation of biomass stocks from sampling based measurements in the baseline and project scenarios of an A/R CDM project activity.

The tool calculates the number of required sample plots on the basis of the specified targeted precision for biomass stocks to be estimated.

The tool applies the following assumptions:

- (a) Approximate value of the area of each stratum within the project boundary is known;
- (b) Approximate value of the variance of biomass stocks in each stratum is known from a preliminary sample, existing data related to the project area, or existing data related to a similar area;
- (c) The project area is stratified into one or more strata.

ESTIMATION OF NON-CO₂ GHG EMISSIONS RESULTING FROM BURNING OF BIOMASS ATTRIBUTABLE TO AN A/R CDM PROJECT ACTIVITY

This tool can be used for estimation of non-CO₂ GHG emissions resulting from all occurrence of fire within the project boundary, i.e. burning of biomass when fire is used for site preparation and/or to clear the land of harvest residue prior to replanting of the land, or when a forest fire occurs within the boundary of an A/R CDM project activity.

For burned areas exceeding a minimum area described in the tool, it provides separate step-by-step calculations and parameter estimation for non-CO₂ GHG emissions from site preparation and from forest fires.

ESTIMATION OF CARBON STOCKS AND CHANGE IN CARBON STOCKS IN DEAD WOOD AND LITTER IN A/R CDM PROJECT ACTIVITIES

This tool can be used for ex post estimation of carbon stocks and change in carbon stocks in dead wood and/or litter in the baseline and project scenarios of an A/R CDM project activity. This tool has no internal applicability conditions.

ESTIMATION OF CARBON STOCKS AND CHANGE IN CARBON STOCKS OF TREES AND SHRUBS IN A/R CDM PROJECT ACTIVITIES

This tool can be used for estimation of carbon stocks and change in carbon stocks of trees and shrubs in the baseline and project scenarios of an A/R CDM project activity. This tool has no specific internal applicability conditions.

ESTIMATION OF THE INCREASE IN GHG EMISSIONS ATTRIBUTABLE TO DISPLACEMENT OF PRE-PROJECT AGRICULTURAL ACTIVITIES IN A/R CDM PROJECT ACTIVITY

This tool provides a step-by-step method for estimating increase in GHG emissions resulting from displacement of pre-project agricultural activities from the project boundary of an A/R project activity under the CDM. The tool estimates the increase in emissions on the basis of changes in carbon stocks in the affected carbon pools in the land receiving the displaced activities.

TOOL FOR ESTIMATION OF CHANGE IN SOIL ORGANIC CARBON STOCKS DUE TO THE IMPLEMENTATION OF A/R CDM PROJECT ACTIVITIES

This tool estimates the change, occurring in a given year, in soil organic carbon (SOC) stocks of land within the boundary of an A/R CDM project activity. The tool is only applicable if litter remains on site during the A/R CDM project activity and soil disturbance for site preparation and project activity is limited. It is not applicable on land containing organic soils or wetlands, and if specific land management practices with inputs are applied. Specific management practices limitations are listed in the tool for each temperature/moisture regime.

DEMONSTRATING APPROPRIATENESS OF VOLUME EQUATIONS FOR ESTIMATION OF ABOVEGROUND TREE BIOMASS IN A/R CDM PROJECT ACTIVITIES

This tool allows demonstration whether a volume table or volume equation, in combination with selected biomass expansion factors (BEFs) and basic wood density, is appropriate for estimation of aboveground tree biomass in an A/R CDM project activity. It provides criteria for direct applicability of an equation for ex post calculations, and – if these criteria are not met – describes the process required for verification of a volume equation. This tool has no internal applicability conditions.

DEMONSTRATING APPROPRIATENESS OF ALLOMETRIC EQUATIONS FOR ESTIMATION OF ABOVEGROUND TREE BIOMASS IN A/R CDM PROJECT ACTIVITIES

This tool allows demonstration whether an allometric equation is appropriate for estimation of aboveground tree biomass in an A/R CDM project activity. It provides criteria for direct applicability of an equation for ex ante and ex post calculations, and – if these criteria are not met – describes the process required for verification of an allometric equation. This tool has no internal applicability conditions.

DEMONSTRATION OF ELIGIBILITY OF LANDS FOR A/R CDM PROJECT ACTIVITIES

This tool provides a step-by-step method for demonstrating eligibility of land for an A/R CDM project activity. The tool also specifies the types of information and data that are required to be furnished for demonstration of eligibility of land. Aerial photographs or satellite imagery complemented by ground reference data, land-use or land-cover information from maps or digital spatial datasets, and data from ground-based surveys or existing records (e.g. permits or plans, cadaster or owner registers) are allowed to be used for demonstrating land eligibility. The tool also allows use of a written testimony resulting from participatory rural appraisal (PRA) where other form of data is either not available or is inadequate.



CDM Methodology Booklet

Chapter IV

4.3. METHODOLOGIES FOR LARGE-SCALE A/R CDM PROJECT ACTIVITIES

AR-AM0014 Afforestation and reforestation of degraded mangrove habitats



<p>Typical project(s)</p>	<p>Afforestation/reforestation of degraded mangrove habitats.</p>
<p>Type of GHG emissions mitigation action</p>	<ul style="list-style-type: none"> • GHG removal by sinks. <p>GHG removal by increasing carbon stocks in the following pools: above-ground biomass, below-ground biomass, and optionally: deadwood and soil organic carbon.</p>
<p>Important conditions under which the methodology is applicable</p>	<ul style="list-style-type: none"> • The land subject to the project activity is degraded mangrove habitat; • More than 90 % of the project area is planted with mangrove species. If more than 10 % of the project area is planted with non-mangrove species then the project activity does not lead to alteration of hydrology of the project area and hydrology of connected up-gradient and down-gradient wetland area; • Soil disturbance attributable to the A/R CDM project activity does not cover more than 10 % of area.
<p>Important parameters</p>	<p>At validation:</p> <ul style="list-style-type: none"> • Annual increments, allometric equations or biomass expansion factors, root-shoot ratio and density.
	<p>Monitored:</p> <ul style="list-style-type: none"> • Crown cover of trees in baseline, crown cover of shrubs; • Area forested (by species); if selected, area along with shrub crown cover; area of sample plots; • Diameter, and possibly height, of planted trees; • Optionally: diameter of pieces of dead wood.
<p>BASELINE SCENARIO Mangrove habitat (wetland) is degraded but may contain a few mangrove trees of very poor quality, some signs of human activities are visible, e.g. fuel wood collection.</p>	
<p>PROJECT SCENARIO Mangrove forests are standing on lands.</p>	

AR-ACM0003 Afforestation and reforestation of lands except wetlands



Typical project(s)	Afforestation/reforestation of lands other than wetlands.
Type of GHG emissions mitigation action	<ul style="list-style-type: none"> GHG removal by sinks. <p>GHG removal by increasing carbon stocks in the following pools: above-ground biomass, below-ground biomass, and optionally: deadwood, litter, and soil organic carbon.</p>
Important conditions under which the methodology is applicable	<ul style="list-style-type: none"> The land subject to the project activity does not fall in wetland category; Soil disturbance attributable to the project activity does not cover more than 10% of area in each of the following types of land, when these lands are included within the project boundary: <ol style="list-style-type: none"> Land containing organic soils; Land which, in the baseline, is subjected to land-use and management practices and receives inputs listed in the appendix of the methodology.
Important parameters	<p>At validation:</p> <ul style="list-style-type: none"> Crown cover of trees in baseline, crown cover of shrubs; Annual increments, allometric equations or biomass expansion factors, root-shoot ratio and wood density.
	<p>Monitored:</p> <ul style="list-style-type: none"> Area forested (by species); if selected, area along with shrub crown cover; area of sample plots; Diameter, and possibly height, of planted trees.
<p>BASELINE SCENARIO Any lands other than wetlands and no forest stands on the lands.</p>	
<p>PROJECT SCENARIO Forests are planted on lands.</p>	

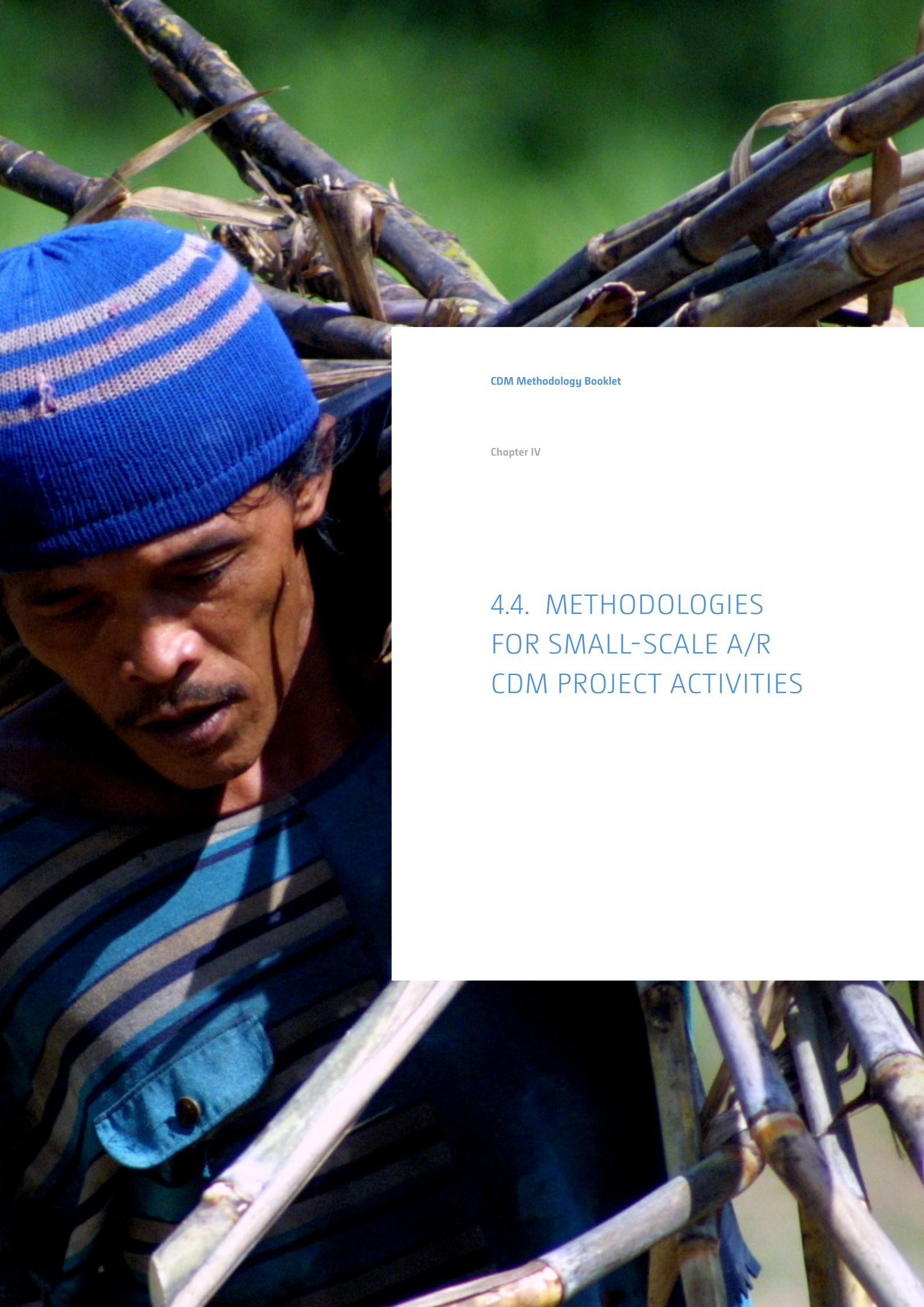

CDM Methodology Booklet

Chapter IV

4.4. METHODOLOGIES FOR SMALL-SCALE A/R CDM PROJECT ACTIVITIES

AR-AMS0003 Small-scale A/R CDM project activities implemented on wetlands



Typical project(s)	Afforestation/reforestation of wetlands.
Type of GHG emissions mitigation action	<ul style="list-style-type: none"> GHG removal by sinks. <p>CO₂ removal by increasing carbon stocks in the following pools: above-ground biomass, below-ground biomass, dead wood and soil organic carbon.</p>
Important conditions under which the methodology is applicable	<ul style="list-style-type: none"> The land subject to the project activity falls under one of the following wetland categories: <ul style="list-style-type: none"> (i) Intertidal wetlands (e.g. mangrove habitats) with a tree crown cover that is less than 20% of the minimum tree crown cover adopted by the host Party for the purpose of definition of forest under the CDM; (ii) Flood plain areas on inorganic soils; (iii) Seasonally flooded areas on margin of water bodies/reservoirs; The project activity does not lead to alteration of the water regime of the project area or areas hydrologically connected to the project area; Soil disturbance attributable to the project activity does not exceed 10% of the project area; The land subject to the project activity does not contain peat soils (histosols).
Important parameters	<p>At validation:</p> <ul style="list-style-type: none"> Crown cover of trees and shrubs in the baseline; Allometric equations or biomass expansion factors with volume equations, root-shoot ratio, basic wood density, and carbon fraction for tree species/species group. <p>Monitored:</p> <ul style="list-style-type: none"> Area of shrub biomass strata and crown cover of shrubs; Area forested (by species) and area of sample plots; Diameter, number and possibly height of planted trees; Area used for agricultural activities displaced by the project activity; Area subjected to burning for site preparation and clearing of harvest residue and forest fires.
<p>BASELINE SCENARIO Lands are degraded wetlands.</p>	
<p>PROJECT SCENARIO Forests are planted on the wetlands.</p>	

AR-AMS0007 Small-scale A/R CDM project activities implemented on lands other than wetlands



Typical project(s)	Afforestation/reforestation of lands other than wetlands.
Type of GHG emissions mitigation action	<ul style="list-style-type: none"> • GHG removal by sinks. <p>CO₂ removal by increasing carbon stocks in the following pools: above-ground biomass, below-ground biomass, optionally deadwood, litter and soil organic carbon.</p>
Important conditions under which the methodology is applicable	<ul style="list-style-type: none"> • The land subject to the project activity does not fall into wetland category; • Soil disturbance attributable to the A/R CDM project activity does not cover more than 10% of area in each of the following types of land, when these lands are included within the project boundary: <ol style="list-style-type: none"> (i) Land containing organic soils; (ii) Land which, in the baseline, is subjected to land-use and management practices and receives inputs as listed in appendix 2 and appendix 3 of the methodology.
Important parameters	<p>At validation:</p> <ul style="list-style-type: none"> • Crown cover of trees and shrubs in the baseline at the start of the A/R CDM project activity; • Allometric equations or biomass expansion factors with volume equations, root-shoot ratio, basic wood density, and carbon fraction for tree species/species group. <hr/> <p>Monitored:</p> <ul style="list-style-type: none"> • Area of shrub biomass strata and crown cover of shrubs; • Area forested (by species) and area of sample plots; • Diameter, number, and possibly height of planted trees; • Area subjected to burning for site preparation and clearing of harvest residue and forest fires.
<p>BASELINE SCENARIO Any lands other than wetlands and no forest stands on the lands.</p>	<p>The diagram shows a yellow background with a diagonal line pattern. On the left, under 'LAND COVER', there are two icons: 'Forest' (a tree) and 'Wetland' (a water body with reeds), both crossed out with a blue 'X'. On the right, under 'ACTIVITIES', there is a 'Biomass' icon (a leaf with a CO₂ molecule). An arrow points from the biomass icon to a 'CO₂' icon, indicating emissions.</p>
<p>PROJECT SCENARIO Forests are planted on lands.</p>	<p>The diagram shows a green background with a diagonal line pattern. On the left, under 'LAND COVER', there is a 'Forest' icon (a tree). On the right, under 'ACTIVITIES', there is a 'Planting' icon (a hand holding a sapling). An arrow points from the planting icon to a 'CO₂' icon, indicating emissions.</p>