



AWMS METHANE RECOVERY PROJECT BR06-S-23, MATO GROSSO AND GOIAS, BRAZIL

UNFCCC Clean Development Mechanism
Simplified Project Design Document
for
Small Scale Project Activity



DOCUMENT ID: BR06-S-23

VER 4, 24 OCT 2007



**CLEAN DEVELOPMENT MECHANISM
SIMPLIFIED PROJECT DESIGN DOCUMENT
FOR SMALL-SCALE PROJECT ACTIVITIES (SSC-CDM-PDD)
Version 02**

CONTENTS

- A. General description of the small-scale project activity
- B. Baseline methodology
- C. Duration of the project activity / Crediting period
- D. Monitoring methodology and plan
- E. Calculation of GHG emission reductions by sources
- F. Environmental impacts
- G. Stakeholders comments

Annexes

- Annex 1: Information on participants in the project activity
- Annex 2: Information regarding public funding
- Annex3: Baseline information
- Annex4: Monitoring information



Revision history of this document

Version Number	Date	Description and reason of revision
01	21 January 2003	Initial adoption
02	8 July 2005	<ul style="list-style-type: none">• The Board agreed to revise the CDM SSC PDD to reflect guidance and clarifications provided by the Board since version 01 of this document.• As a consequence, the guidelines for completing CDM SSC PDD have been revised accordingly to version 2. The latest version can be found at http://cdm.unfccc.int/Reference/Documents.

**SECTION A. General description of the small-scale project activity****A.1. Title of the small-scale project activity:**

AWMS Methane Recovery Project BR06-S-23, **Mato Grosso and Goias, Brazil**

A.2. Description of the small-scale project activity:

Purpose: The purpose of this project is to mitigate and recover animal effluent related GHG by improving AWMS practices.

Worldwide, agricultural operations are becoming progressively more intensive to realize economies of production and scale. The pressure to become more efficient drives significant operational similarities between farms of a “type,” as inputs, outputs, practices, genetics, and technology have become similar around the world.

This is especially true in livestock operations (swine, dairy cows, etc.) which can create profound environmental consequences, such as greenhouse gas emissions, odour, and water/land contamination (including seepage, runoff, and over application), that result from storing (and disposing of) animal waste. Confined Animal Feeding Operations (CAFOs) use similar Animal Waste Management System (AWMS) options to store animal effluent. These systems emit both methane (CH₄) and nitrous oxide (N₂O) resulting from both aerobic and anaerobic decomposition processes.

This project proposes to apply the Methane Recovery methodology identified in Section III.D, of the Indicative Simplified Baseline and Monitoring Methodologies for Small-Scale CDM Project Activity Categories, to swine CAFOs located in Mato Grosso and Goias, Brazil. The proposed project activities will mitigate and recover AWMS GHG emissions in an economically sustainable manner, and will result in other environmental benefits, such as improved water quality and reduced odour. In simple terms, the project proposes to move from a high-GHG AWMS practice, an open air lagoon, to a lower-GHG AWMS practice, an anaerobic digester with capture and combustion of resulting biogas.

Contribution to sustainable development:

According to Brazil’s *Inter-Ministerial Commission on Global Climatic Change*,¹ manure management is an important issue that needs to be solved. Failure to do so will allow existing problems (e.g., increased (insect) pest populations, problems with allergies and livestock disease, including foot-and-mouth disease (FMD) which exists in Brazil), to continue unabated. To this end, Brazil has in recent years required all CAFOs to transition from single to multi-lagoon systems, and even more recently has required them to line the bottom of their primary sedimentation lagoon to prevent effluent seepage.²

¹ <http://www.ambientebrasil.com.br>

² A re-lined lagoon typically delivers a nominal 20-30 years of performance. For additional data refer to: R.J. McMillan, et al, “Studies of Seepage Beneath Earthen Manure Storages and Cattle Pens in Manitoba,” Manuscript in Preparation, University of Manitoba & The Water Branch of Manitoba; Ground Water Monitoring & Assessment Program, (2001) “Effects of Liquid Manure Storage Systems on Ground Water Quality,” Minnesota Pollution Control Agency; American Society of Agricultural Engineers, (2003) “Seepage Losses From Animal Waste Lagoons: A Summary of a Four Year Investigation in Kansas”, Technical Library



Establishing a positive model for other livestock operations is essential. In the last ten years, Brazilian swine production grew by 28%, reaching breeding levels of approximately 36 million animals.³ In 2004, the swine population in Mato Grosso and Goiás was approximately 2.8 million.⁴ Considering that a typical hog produces 5.8 kilograms of effluent daily (Table A1), annually some 5.9 million metric tons of hog waste is produced in this state alone. Introducing progressive AWMS practices throughout the region could result in an annual reduction of over 1.77 million tonnes⁵ of carbon dioxide equivalent (CO₂e) annually.

Table A1. Daily production of effluent by type of porcine⁶

Stage	Manure kg/day	Manure and Urine kg/day	Volume litres/day	Volume m ³ /animal/month
25-100 kg	2.3	4.9	7.0	.25
Gestating sows	3.6	11.0	16.0	.48
Nursing sows	6.4	18.0	27.0	.81
Boar pig	3.0	6.0	9.0	.28
Piglet	0.35	0.95	1.4	.05
Average	2.35	5.8	8.6	.27

Furthermore, the proper handling of this large quantity of CAFO animal waste is critical to protecting human health and the environment. Because of the practices employed by farmers, the design, location, and management of livestock operations are critical components in ensuring an adequate level of protection of human health and the environment.⁷

This project activity will have positive effects on the local environment by improving air quality (i.e., reducing the emission of Volatile Organic Compounds (VOCs) and odour) and will set the stage for future on-farm projects (i.e., changes in land application practices) that will have an additional positive impact on GHG emissions with an attendant potential for reducing groundwater contamination problems.

This project activity will also increase local employment of skilled labour for the fabrication, installation, operation and maintenance of the specialized equipment. Finally, this voluntary project activity will establish a model for world-class, scalable animal waste management practices, which can be duplicated on other CAFO livestock farms throughout Brazil, dramatically reducing livestock related GHG and providing the potential for a new source of revenue and green power.

The proposed methane recovery project uniquely satisfies the Brazilian government priorities for environmental stewardship and sustainability while positioning rural agricultural operations to develop

³ Anaulpec, 2001

⁴ ftp://ftp.ibge.gov.br/Producao_Pecuaria/Producao_da_Pecuaria_Municipal_%5Banual%5D/2004/grandes_regioes_Ufs.zip

⁵ Approximate calculation using IPCC model and emission factors

⁶ Kruger I, Taylor G, Ferrier M (eds) (1995) 'Australian pig housing series: effluent at work' (NSW Agriculture: Tamworth). Another outstanding reference for manure output is: Lorimor, Powers, et.al "Manure Characteristics", Manure Management Series, MWPS-18, Section 1; pg 12.

⁷ Speir, Jerry; Bowden, Marie-Ann; Ervin, David; McElfish, Jim; Espejo, Rosario Perez, "Comparative Standards for Intensive Livestock Operations in Canada, Mexico, and the U.S.," Paper prepared for the Commission for Environmental Cooperation.



and use renewable (“green”) power. Indeed, it does so with no negative consequences and with a series of environmental and infrastructure co-benefits.

Because the proposed project establishes an advanced AWMS the project participants believe the farm managers will adopt – and continue to practice – AWMS practice changes that result in meaningful, and permanent, GHG emission reductions beyond the project’s expected lifespan.

A.3. Project participants:

Name of Party involved (*) (host) indicates a host Party)	Private and/or public entity(ies) project participants (*) (as applicable)	Kindly indicate if the Party involved wishes to be considered as project participant (Yes/No)
Brazil (host)	<ul style="list-style-type: none"> AgCert Do Brasil Solucoes Ambientais Ltda. 	No

A.4. Technical description of the small-scale project activity:

A.4.1. Location of the small-scale project activity:

A.4.1.1. Host Party(ies):

The host party for this project activity is **Brazil**.

A.4.1.2. Region/State/Province etc.:

The project will be located in **Mato Grosso and Goias**.

A.4.1.3. City/Town/Community etc:

The project sites are shown in Figure A1 with specifics detailed in Table A2.

A.4.1.4. Detail of physical location, including information allowing the unique identification of this small-scale project activity(ies):

The physical location of each of the sites involved in this project activity is shown in Figure A1 and listed in Table A2.

Cássio Bellintani Iplinsky has one site in Goias:

- Fazenda Alvorada (21932) is a finishing operation with a capacity of over 4,000 animals. Four containment areas house the animals and the scraper method of manure removal is used. Waste from all the containment areas is divided into three primary open lagoons. Irrigation is used to



dispose of effluent. The producer intends to increase his production by 20% over a total of 10 years.

Gustavo Bellintani Iplinsky has one site in Goiás:

- Fazenda Alvorada (21942) is a finishing operation with a capacity of over 4,000 animals. The animals are housed in four containment areas from which manure is removed utilizing the scraper method. Waste from all the containment areas is distributed into three primary open lagoons and effluent is disposed of through irrigation. The producer intends to increase his production by 20% over a total of 10 years.

Fabio Bellintani Iplinsky has one site in Goiás:

- Fazenda Alvorada (21952) is a finishing operation with a capacity of over 4,000 animals. A total of four containment areas house the animals and scraping is used to remove manure from them. Waste from the containment areas is divided into three primary open lagoons. The method of effluent disposition in use is irrigation. The producer intends to increase his production by 20% over a total of 10 years.

Dourivan Cruvinel de Souza has two sites in Goiás. Both sites use proprietary Dalland software to track inventory:

- Fazenda São Tomé (27052) is a farrowing operation with a capacity of over 500 animals. The animals are housed in four containment areas from which manure is removed by scraping. Three primary open lagoons comprise this site's AWMS and effluent is disposed of through the surface spread method.
- Fazenda São Tomé Sitio II (27062) is a farrow to finish operation. Three containment areas with a capacity of over 4,000 house the animals. Manure is removed utilizing the scraper method. This site has four primary open lagoons for its AWMS. Lagoon #3 is currently not in use. Surface spread is used to dispose of effluent.

Luciano Tadeu de Moura has one site in Goiás:

- Fazenda São Tomé (26842) is a farrowing operation with a capacity of over 5,000 animals. The animals are housed in four containment areas from which manure is removed by scraping. Waste is distributed among this site's four primary open lagoons and irrigation is used to dispose of effluent.

Alexandre Jackes Bottan has one site:

- Granja Adriana (28102) is a farrow to finish operation with a capacity of nearly 12,000 animals. Eleven containment areas house the animals, all but one of which use the scraper method to remove manure. Containment area 6, which houses nursers, uses the pull plug method to remove manure. Waste from all the containment areas flows into nine open lagoons in succession. Surface spread is used to dispose of effluent.

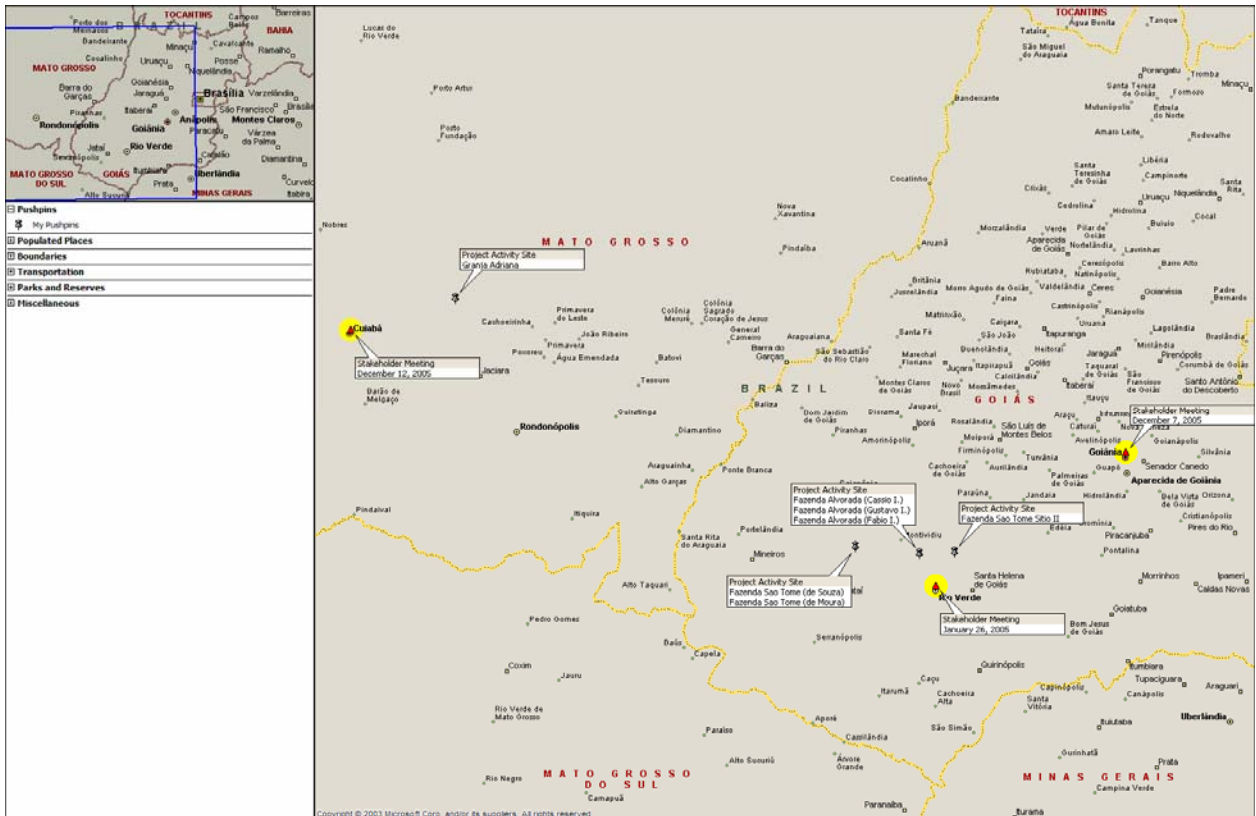

Figure A1. States of Goiás and Mato Grosso, Brazil project activity sites

**Table A2. Detailed physical location and identification of project sites**

Farm/Site Name	AgCert ID	Address	Town / State	Contact	Phone	GPS Coord
Fazenda Alvorada	21932	Rodovia GO 174 - Km. 32	Rio Verde, Goias	Cássio Bellintani Iplinsky	55 64 3612-1212	17.555772S 51.06569W
Fazenda Alvorada	21942	Rodovia GO 174 - Km. 32	Rio Verde, Goias	Gustavo Bellintani Iplinsky	55 64 3612-1212	17.541993S 51.065618W
Fazenda Alvorada	21952	Rodovia GO 174 - Km. 32	Rio Verde, Goias	Fábio Bellintani Iplinsky	55 64 3612-1212	17.543845S 51.071977W
Dourivan Cruvinel de Souza	Home Office	Rua Goiania, nº. 941 Centro				n/a
Fazenda São Tomé	27052	Rodovia BR 060, Km 48, á direita, Zona Rural	Rio Verde, Goias	Dourivan Cruvinel de Souza	55 64 613-9252	17.50S 51.64W
Fazenda São Tomé Sítio II	27062					17.536938S 50.758493W
Fazenda São Tomé	26842	Rodovia BR 060, Km 422, Sentido Jataí, Zona Rural	Rio Verde, Goias	Luciano Tadeu de Moura	55 64 3622-1621	17.533738S 51.642957W
Granja Adriana	28102	Rodovia MT 140 Km 32 Sentido Campo Verde a Nova Brasilândia + 5 Km a Direita	Campo Verde, Mato Grosso	André Angelo Bottan	55 66 3419 2019	15.378468S 55.163872W

**A.4.2. Type and category(ies) and technology of the small-scale project activity:**

The project activity described in this document is classified as a Type III, Other Project Activities, Category III.D./Ver 11, Methane recovery in agricultural and agro industrial activities.

The project activity will capture and combust methane gas produced from the decomposing manure of swine CAFOs located in Mato Grosso and Goias, Brazil.

The technology to be employed by the project activity includes the installation of new covered lagoons creating an anaerobic digester. The system will be comprised of a lined and covered lagoon creating a digester with sufficient capacity and Hydraulic Retention Time (HRT) to greatly reduce the volatile solids loading in the effluent. The cover consists of a synthetic high density polyethylene (HDPE) geomembrane, which is secured to the liner by means of an anchor trench around the perimeter. HDPE is the most commonly used geomembrane in the world and is well suited for use in this project. HDPE is an excellent product for large applications that require UV, ozone, and chemical resistance. The digester has been designed to permit solids residue removal without breaking the gas retention seal. Processed effluent from the digester(s) will be routed to a secondary and tertiary lagoon system, as needed, and captured biogas will be routed to an efficient combustion system to destroy methane gas produced. Special maintenance procedures have been developed to ensure proper handling and disposition of the digester sludge.

The enclosed flaring combustion system is automated to ensure that all biogas that exits the digester and passes through the flare (and flow meter) is combusted. Pressure control devices within the gas handling system maintain proper biogas flow to the combustion system. A continuous ignition system ensures methane combustion whenever biogas is present at the flare. Two (2) sparking electrodes provide operational redundancy. If biogas is present in the flare, it is immediately ignited by the sparking system. If biogas is not present, the igniter sparks harmlessly approximately every 3 seconds. This continuous ignition system is powered by a robust solar module (solar-charged battery system) that operates independently from the power grid. With a fully charged battery, the module will provide power to the igniter for up to two weeks without sunlight. The component parts are verified functional on a periodic basis in accordance with manufacturer and other technical specifications.

Technology and know-how transfer:

The project developer is implementing a multi-faceted approach to ensure the project, including technology transfer, proceeds smoothly. This approach includes careful specification and design of a complete technology solution, identification and qualification of appropriate technology/services providers, supervision of the complete project installation, farm staff training, ongoing monitoring (by the project developer) and developing/implementing a complete Monitoring Plan using project developer staff. As part of this process, the project developer has specified a technology solution that will be self-sustaining (i.e., highly reliable, low maintenance, and operate with little or no user intervention). The materials and labour used in the base project activity are sourced from the host country whenever economically possible.

By working so closely with the project on a “day to day” basis, the project developer will ensure that all installed equipment is properly operated and maintained, and will carefully monitor the data collection



and recording process. Moreover, by working with the farm staff over many years, the project developer will ensure that the staff acquires appropriate expertise and resources to operate the system on an ongoing/continuous basis.

A.4.3. Brief explanation of how the anthropogenic emissions of anthropogenic greenhouse gas (GHGs) by sources are to be reduced by the proposed small-scale project activity, including why the emission reductions would not occur in the absence of the proposed small-scale project activity, taking into account national and/or sectoral policies and circumstances:

Anthropogenic GHGs, specifically methane is released into the atmosphere via decomposition of animal manure. Currently, the farm produced GHG is not collected or destroyed.

The proposed project activity intends to change current AWMS practices. These changes will result in the recovery of anthropogenic GHG emissions by controlling the lagoon's decomposition processes and collecting and combusting the methane biogas.

**A.4.3.1 Estimated amount of emission reductions over the chosen crediting period:****THE TOTAL ESTIMATE OF EMISSIONS REDUCTION OVER THE 10 YEAR CREDITING PERIOD**

A.4.3.1 - Estimated Emission Reductions over chosen Crediting Period	
Years	Annual estimation of emission reductions in tonnes of CO₂e
Year 1	16,447
Year 2	16,585
Year 3	16,726
Year 4	16,870
Year 5	17,017
Year 6	17,167
Year 7	17,320
Year 8	17,476
Year 9	17,635
Year 10	17,797
Total estimated reductions (tonnes CO₂e)	171,041
Total number of crediting years	10
Annual average over the crediting period of estimated reductions (tonnes of CO₂e)	17,104

A.4.4. Public funding of the small-scale project activity:

There is no official development assistance being provided for this project.

A.4.5. Confirmation that the small-scale project activity is not a debundled component of a larger project activity:

Based on paragraph 2 of Appendix C of the Simplified Modalities and Procedures for Small-Scale CDM project activities,⁸ this project is not debundled. There are no other registered small-scale CDM project activities with the same project participants, in the same project category and technology/measure whose project boundary is within 1 km of another proposed small-scale activity.

SECTION B. Application of a baseline methodology:

⁸ <http://cdm.unfccc.int/EB/Meetings/007/eb7ra07.pdf>

**B.1. Title and reference of the approved baseline methodology applied to the small-scale project activity:**

The project activity is a Type III, Other Project Activities, Category III.D./Ver 11, Methane recovery in agricultural and agro industrial activities. The project is a small scale project because it comprises methane recovery from agro-industries, and project emissions are less than 60 kt CO₂eq.

B.2 Project category applicable to the small-scale project activity:

The simplified methodologies are appropriate because the project activity site is considered an agro-industry and GHG emissions calculations can be estimated using internationally accepted IPCC guidance.

The project activity will capture and combust methane gas produced from the decomposing manure at swine CAFOs located in Mato Grosso and Goias, Brazil. This simplified baseline methodology is applicable to this project activity because without the proposed project activity, methane from the existing AWMS would continue to be emitted into the atmosphere.

B.3. Description of how the anthropogenic emissions of GHG by sources are reduced below those that would have occurred in the absence of the registered small-scale CDM project activity:

Anthropogenic GHGs, specifically methane, are released into the atmosphere via decomposition of animal manure. Currently, this farm-produced biogas is not collected or destroyed.

The proposed project activity intends to improve current AWMS practices. These changes will result in the mitigation of anthropogenic GHG emissions, specifically the recovery of methane, by controlling the lagoon's decomposition processes and collecting and combusting the biogas.

There are no existing, pending, or planned national, state, or local regulatory requirements that govern GHG emissions from agro-industry operations (specifically, pork production activities) as outlined in this PDD. The project participants have solicited information regarding this issue during numerous conversations with local and state government officials and through legal representation and have determined there is no regulatory impetus for producers to upgrade current AWMS beyond existing open air lagoon. The following paragraphs discuss the Brazilian pork industry and how conditions hinder changes in AWMS practices.

Assessment of barriers:

Absent CDM project activities, the proposed project activity has not been adopted on a national or worldwide scale due to the following barriers:

- a. *Investment Barriers:* This treatment approach is considered one of the most advanced AWMS systems in the world. Only a few countries have implemented such technology because of the high investment costs compared to other available systems and due to regionalized subsidies for electric generation. The Brazilian energy market does not currently offer incentives to sell biogas into the grid. The investment required to produce energy by utilizing biogas is still too high compared to electricity prices in Brazil. Additionally, much of the power distributed in Brazil is derived from hydroelectric sources.



EMBRAPA noted that in general, producers view the AWMS as a stage that is outside of the production process and have difficulty financing changes that should be undertaken. Even banks have been unwilling to finance such activities absent government guarantees or other incentives. Professor Dr. Carlos Cláudio Perdomo, a swine and poultry researcher from EMBRAPA, states: “Many producers don’t possess the capacity of investment for a new AWMS. Even the big large producing farms that require more sophisticated systems also lack this capacity of investment.”⁹

- b. *Technology barriers:* Anaerobic digester systems have to be sized to handle projected animal/effluent volumes with a Hydraulic Retention Time (HRT) consistent with extracting most/all CH₄ from the manure. These systems become progressively more expensive on a ‘per animal’ basis as farm animal population (i.e., farm size) is decreased. Moreover, operations and maintenance requirements involved with this technology, including a detailed monitoring program to maintain system performance levels, must also be considered. Worldwide, few anaerobic digesters have achieved long-term operations, due primarily to inappropriate operations and maintenance.

The proposed AWMS represents the most advanced AWMS technology in the state. The proposed project activity AWMS mitigates GHG emissions with associated environmental co-benefits.

- ~~e. *Legal barriers:* The implementation of this project activity by these farms highly exceeds current Brazilian regulations for swine waste treatment. Apart from existing legislation in Brazil that establishes water quality parameters that require lagoons to be lined, hence protecting water supplies from contamination, there is no legislation in place that requires specific swine manure treatment, especially as it relates to the emission of GHG.~~

Per local and state officials as well as the project developer’s legal consul, there were no existing laws or regulations, nor were any anticipated, that would require these farms to change their open lagoon AWMS practice in order to mitigate GHG emissions. An analysis was performed to assess whether the basis in choosing the baseline scenario is expected to change during the crediting period and the results follow:

- a) *Legal constraints:* There is no expectation that Brazilian legislation will require future use of digesters due to the significant investments required. Further, there is no expectation that Brazil will pass any legislation which deals with the GHG emissions (see Step 4c above).
- b) *Common practice:* While past practices cannot predict future events, it is worth noting most farms (see Table A2) have been in existence for many years, during which time most have only used open lagoons as their AWMS practice. Local agricultural officials/inspectors confirmed (at the stakeholders’ meeting) that open lagoons have always been used at these farms.

These anaerobic lagoon systems are economically feasible, reliable, effective, and satisfy regulatory and social requirements, and there is no reason to expect that these conditions will change in the foreseeable future.

B.4. Description of how the definition of the project boundary related to the baseline methodology selected is applied to the small-scale project activity:

The project boundary is illustrated in Figure B1. It describes the basic layout of the project farm in a schematic format. The proposed project boundary considers the GHG emissions that come from AWMS

⁹ http://www.jornalexpress.com.br/noticiais/detalhes.php?id_jornal=2&id_noticia=5802

practices, including the GHG resulting from the capture and combustion of biogas. The project activity site uses a system of one or more lagoons. Proposed AWMS practice changes include the construction of a digester comprised of cells that capture the resulting bio-gas which is then combusted. Based on the methodology, the anaerobic digester is the physical boundary of the methane recovery facility.

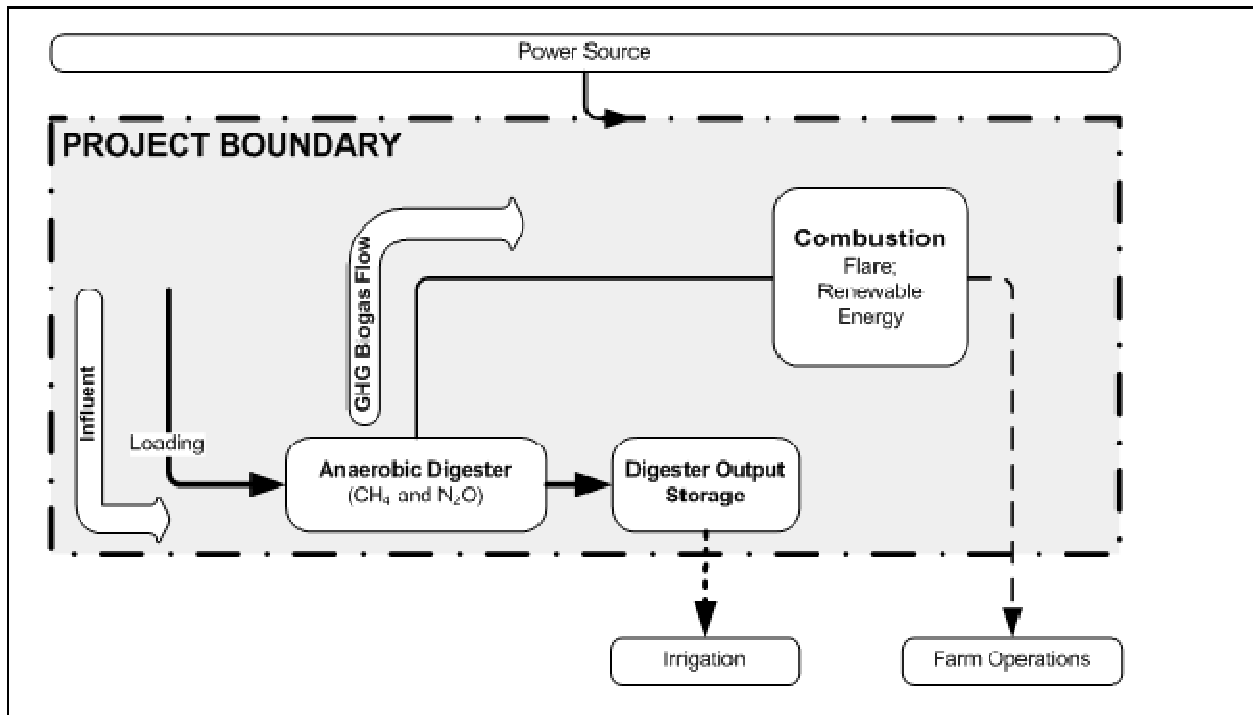

Figure B1. Project Boundary

B.5. Details of the baseline and its development:

The amount of methane that would be emitted to the atmosphere in the absence of the project activity can be estimated by referring to Table 10.17 of the 2006 IPCC Guidelines for National GHG Inventories.

The final draft of this baseline section was completed on 11/12/2006. The name of entity determining the baseline is AgCert. AgCert is a project participant, as well as the project developer.



The baseline for this project activity is defined as the amount of methane that would be emitted to the atmosphere during the crediting period in the absence of the project activity. In this case an open anaerobic lagoon is considered the baseline and estimated emissions are determined as follows:

Step 1 – Animal Population

Animal populations for the project activity sites are described in the Section E.1.2.1, Table E1. The AWMS used on the farms is an open anaerobic lagoon, unless otherwise noted in Section A.4.1.4.

Step 2 – Emission Factors

The emission factor for the animal group is:

$$EF_i = VS_i * n_m * B_{oi} * 0.67\text{kg/m}^3 * MCF_{jk} * MS\%_{ijk}$$

Equation B1¹⁰

Where:

- EF_i = emission factor (kg) for animal type i (e.g., swine, weight adjusted),
- VS_i = Volatile solids excreted in kg/day for animal type i, max Vs is 0.5 kg/head/day (adjusted as $VS = (W_{\text{site}}/W_{\text{default}})^{11} * VS_{\text{IPCC}}$)
- n_m = Number of days animals present,
- B_o = Maximum methane producing capacity (m^3/kg of VS) for manure produced by animal type i,
- MCF_{jk} = Methane conversion factor for each manure management system j by climate region k; and
- $MS\%_{ijk}$ = fraction of animal type i's manure handled using manure system j in climate region k.

The amount of methane emitted can be calculated using:

$$CH_{4a} = EF_i * Population_{\text{year}}$$

Equation B2¹²

¹⁰ 2006 IPCC Guidelines for National Greenhouse Gas Inventories. Page 10.41 Equation 10.23 and Tables 10A-7 and 10A-8, p. 10.81 and 10.82

¹¹ Obtained from 2006 IPCC, Annex 10A.2, Tables 10A-7 and 10A-8, p. 10.81 and 10.82



Where:

- CH_{4a} = methane produced in kg/yr for animal type i,
 EF_i = emission factor (kg) for animal type i (e.g., swine),
 $Population_{year}$ = yearly average population of animal type i.

Step 3 – Total Baseline Emissions

To estimate total yearly methane emissions the selected emission factors are multiplied by the associated animal population and summed.

$$BE = [CH_{4a} * GWP_{CH4}]/1000$$

Equation B3¹³

Where:

- BE = Baseline carbon dioxide equivalent emission in metric tons per year,
 CH_{4a} = annual methane produced in kg/yr for animal type i,
 GWP_{CH4} = global warming potential of methane (21).

SECTION C. Duration of the project activity / Crediting period:

C.1. Duration of the small-scale project activity:

C.1.1. Starting date of the small-scale project activity:

The starting date for this activity is 15/08/2005.

C.1.2. Expected operational lifetime of the small-scale project activity:

The expected life of this project is 12y 11m.

C.2. Choice of crediting period and related information:

The project activity will use a **fixed** crediting period.

C.2.1. Renewable crediting period:

C.2.1.1. Starting date of the first crediting period:

¹² Adapted from 2006 IPCC Guidelines for National Greenhouse Gas Inventories. Page 10.41, Equation 10.23.

¹³ Adapted from Equation 9, page 12, AM0016/version 02, 22 October 2004 / UNFCCC / CDM Meth Panel

**C.2.1.2. Length of the first crediting period:****C.2.2. Fixed crediting period:****C.2.2.1. Starting date:**

The starting date of the crediting period is 15/08/2007.

C.2.2.2. Length:

The length of the crediting period is **10y 0m**.

SECTION D. Application of a monitoring methodology and plan:**D.1. Name and reference of approved monitoring methodology applied to the small-scale project activity:**

The methodology applied to this project activity is AMS-III.D./Ver 11, Methane recovery in agricultural and agro industrial activities.

D.2. Justification of the choice of the methodology and why it is applicable to the small-scale project activity:

The simplified monitoring methodologies are applicable to this project activity because they provide a method to accurately measure and record the GHG emissions that will be captured and combusted by the project activity.

D.3 Data to be monitored:

See Table D1 for specific parameters to be monitored.



Table D1. Data to be monitored

ID number	Data type	Data variable	Data unit	Measured (m), calculated (c) or estimated (e)	Recording frequency	Proportion of data to be monitored	How will the data be archived?	For how long is archived data to be kept?	Comment
1. SIR	Frequency	Sludge Removal count	#	m	As required	100%	electronic	Duration of project activity +2y	Sludge removal will be accomplished to ensure proper disposition so there is no resulting methane emissions.
2. BGP	Volume	Biogas produced	m ³	m	Monthly	100%	electronic	Duration of project activity +2y	This parameter measures cumulative biogas produced. A biogas meter will continuously measure amount of biogas produced.
3. MC	Percent	Methane content	%	m	Quarterly	100%	electronic	Duration of project activity +2y	This parameter determines the methane content of the biogas. If significant deviations are observed, more frequent measurements will be taken until the values stabilize.
4. CEE	Fraction of time	Combustion equipment efficiency	%	m	Quarterly	100%	electronic	Duration of project activity +2y	This parameter is used to determine the fraction of time in which gas is combusted. The fraction of time will be determined as 100% less any time the flare is out of service and gas is flowing. Flare maintenance records will be used to make this determination.
5.EFP	Percent	Efficiency of Flaring Process	%	m	Initial and yearly	100%	Electronic or paper	Duration of project activity +2y	AgCert will test the efficiency of the flaring process during initial installation, then perform yearly maintenance to ensure optimal operation.

**D.4. Qualitative explanation of how quality control (QC) and quality assurance (QA) procedures are undertaken:**

AgCert has designed and implemented a unique set of data management tools to efficiently capture and report data throughout the project lifecycle. On-site assessment (collecting Geo-referenced, time/date stamped data), supplier production data exchange, task tracking, and post-implementation auditing tools have been developed to ensure accurate, consistent, and complete data gathering and project implementation. Sophisticated tools have also been created to estimate/monitor the creation of high quality, permanent, ERs using IPCC formulae.

By coupling these capabilities with an ISO based quality and environmental management system, AgCert enables transparent data collection and verification.

D.5. Please describe briefly the operational and management structure that the project participant(s) will implement in order to monitor emission reductions and any leakage effects generated by the project activity:

A complete set of procedures and a Monitoring Plan (Annex 3) has been developed to ensure accurate measurement of biogas produced and proper operation of the digester equipment. This plan exceeds the requirements outlined in the approved methodology outlined in Appendix B of the simplified modalities and procedures for small-scale CDM project activities as it applies to proposed project activity.

Metering devices used are designed to continuously and accurately measure biogas flow and are specially designed for corrosive environments. Meters are received from the factory fully-calibrated and retain calibration for the service life of the unit. Volumetric accuracy of the meter is permanent and non-adjustable. Accuracy is not affected by low or varying line pressures. Accuracy of the flowmeters utilized exceeds 99 percent across the entire measured rate curve with an uncertainty range of less than ± 1 percent. Periodic maintenance will be performed based on manufacturer specifications. Other equipment calibrations are accomplished using procedures developed by the project developer (Annex 4).

Methane concentration is determined using a Bacharach Model Fyrite (or equivalent) gas analyzer. The process is described in the Monitoring Plan. The measuring equipment is calibrated in accordance with the manufacturer specifications. The equipment is accurate to within 0.5%.

An industry standard gas analyser (Landtec GEM-500 or equivalent) will be used when measuring methane content of the biogas to determine the efficiency of the flaring process. The unit will be calibrated to an accuracy of ± 1 percent.

Further, AgCert has a trained staff located in the host nation to perform O&M activities including but not limited to monitoring and collection of parameters, quality audits, personnel training, and equipment inspections. The associated Monitoring Plan has been developed to provide guidance (work instructions) to individuals that collect and/or process data. AgCert staff will perform audits of farm operations personnel on a regular basis to ensure proper data collection and handling.

**D.6. Name of person/entity determining the monitoring methodology:**

The entity determining this monitoring methodology is AgCert, who is the project developer listed in Annex 1 of this document.

SECTION E.: Estimation of GHG emissions by sources:**E.1. Formulae used:****E.1.1 Selected formulae as provided in appendix B:**

Specific formula to calculate the GHG emission reductions by sources for the AWMS improvement are not provided in appendix B of the simplified M&P for small-scale CDM project activities.

E.1.2 Description of formulae when not provided in appendix B:**E.1.2.1 Describe the formulae used to estimate anthropogenic emissions by sources of GHGs due to the project activity within the project boundary:**

The amount of methane that would be emitted to the atmosphere due to the project activity and within the project boundaries can be estimated by referring to Table 10.17 of the 2006 IPCC Guidelines for National GHG Inventories.

The project emissions for this project activity are defined as the amount of methane that would be emitted to the atmosphere during the crediting period due to the project activity. In this case an anaerobic digester is considered the project activity and estimated emissions are determined as follows:

Step 1 – Animal Population

Animal populations for the project activity sites are described in the tables below. The AWMS proposed for use on the farm is an anaerobic digester.



Table E1, Animal Populations

	Month/Yr	Animal Type				
		Sow	Gilt	Boar	Fin	Nurs
Fazenda Alvorada (21932)	Jan-05	0	0	0	3,468	0
	Feb-05	0	0	0	3,468	0
	Mar-05	0	0	0	3,468	0
	Apr-05	0	0	0	3,468	0
	May-05	0	0	0	3,468	0
	Jun-05	0	0	0	3,468	0
	Jul-05	0	0	0	3,468	0
	Aug-05	0	0	0	3,468	0
	Sep-05	0	0	0	3,468	0
	Oct-05	0	0	0	3,468	0
	Nov-05	0	0	0	3,468	0
	Dec-05	0	0	0	3,468	0
This is a new site with less than 12 months of animal inventory available so AgCert used conservative inventory estimates of 85% of capacity.						
Fazenda Alvorada (21942)	Jan-05	0	0	0	3,468	0
	Feb-05	0	0	0	3,468	0
	Mar-05	0	0	0	3,468	0
	Apr-05	0	0	0	3,468	0
	May-05	0	0	0	3,468	0
	Jun-05	0	0	0	3,468	0
	Jul-05	0	0	0	3,468	0
	Aug-05	0	0	0	3,468	0
	Sep-05	0	0	0	3,468	0
	Oct-05	0	0	0	3,468	0
	Nov-05	0	0	0	3,468	0
	Dec-05	0	0	0	3,468	0
This is a new site with less than 12 months of animal inventory available so AgCert used conservative inventory estimates of 85% of capacity.						



	Month/Yr	Animal Type				
		Sow	Gilt	Boar	Fin	Nurs
Fazenda Alvorada (21952)	Jan-05	0	0	0	3,468	0
	Feb-05	0	0	0	3,468	0
	Mar-05	0	0	0	3,468	0
	Apr-05	0	0	0	3,468	0
	May-05	0	0	0	3,468	0
	Jun-05	0	0	0	3,468	0
	Jul-05	0	0	0	3,468	0
	Aug-05	0	0	0	3,468	0
	Sep-05	0	0	0	3,468	0
	Oct-05	0	0	0	3,468	0
	Nov-05	0	0	0	3,468	0
	Dec-05	0	0	0	3,468	0
This is a new site with less than 12 months of animal inventory available so AgCert used conservative inventory estimates of 85% of capacity.						
	Month/Yr	Animal Type				
		Sow	Gilt	Boar	Fin	Nurs
Fazenda Sao Tome (27052)	Nov-04	559	49	6	0	0
	Dec-04	554	57	6	0	0
	Jan-05	544	60	6	0	0
	Feb-05	538	51	6	0	0
	Mar-05	548	47	6	0	0
	Apr-05	543	57	6	0	0
	May-05	537	55	6	0	0
	Jun-05	541	60	6	0	0
	Jul-05	537	62	6	0	0
	Aug-05	539	59	6	0	0
	Sep-05	544	65	6	0	0
	Oct-05	551	66	6	0	0



	Month/Yr	Animal Type				
		Sow	Gilt	Boar	Fin	Nurs
Fazenda Sao Tome Sitio II (27062)	Nov-04	0	0	0	1,959	1,840
	Dec-04	0	0	0	2,085	1,723
	Jan-05	0	0	0	2,320	1,850
	Feb-05	0	0	0	2,446	1,835
	Mar-05	0	0	0	2,221	1,908
	Apr-05	0	0	0	2,280	1,858
	May-05	0	0	0	2,117	1,836
	Jun-05	0	0	0	2,251	1,704
	Jul-05	0	0	0	2,445	1,767
	Aug-05	0	0	0	2,255	1,708
	Sep-05	0	0	0	2,085	1,627
	Oct-05	0	0	0	2,082	1,677
	Month/Yr	Animal Type				
		Sow	Gilt	Boar	Fin	Nurs
Fazenda Sao Tome (26842)	Dec-04	1,246	0	0	0	3,698
	Jan-05	1,246	0	0	0	3,698
	Feb-05	1,246	0	0	0	3,698
	Mar-05	1,246	0	0	0	3,698
	Apr-05	1,246	0	0	0	3,698
	May-05	1,246	0	0	0	3,698
	Jun-05	1,246	0	0	0	3,698
	Jul-05	1,246	0	0	0	3,698
	Aug-05	1,246	0	0	0	3,698
	Sep-05	1,246	0	0	0	3,698
	Oct-05	1,246	0	0	0	3,698
	Nov-05	1,246	0	0	0	3,698



	Month/Yr	Animal Type				
		Sow	Gilt	Boar	Fin	Nurs
Granja Adriana (28102)	Jan-05	795	103	10	1,871	2,557
	Feb-05	806	92	8	3,730	1,587
	Mar-05	804	147	11	5,285	1,888
	Apr-05	805	185	11	6,485	2,384
	May-05	804	229	10	7,575	2,403
	Jun-05	828	287	10	7,529	2,083
	Jul-05	840	298	13	7,499	2,090
	Aug-05	858	264	13	7,609	1,673
	Sep-05	846	233	11	7,674	2,404
	Oct-05	869	239	11	7,662	2,413
	Nov-05	869	227	14	7,612	2,404
	Dec-05	850	225	14	8,045	2,399

Step 2 – Emission Factors

The emission factor for the animal group is:

$$EF_i = VS_i * n_m * B_{oi} * 0.67\text{kg/m}^3 * MCF_{jk} * MS\%_{ijk}$$

Equation E2¹⁴

Where:

- EF_i = emission factor (kg) for animal type i (e.g., swine, weight adjusted),
- VS_i = Volatile solids excreted in kg/day for animal type i, max Vs is 0.5 kg/head/day (adjusted as $VS = (W_{\text{site}}/W_{\text{default}})^{15} * VS_{\text{IPCC}}$)
- n_m = Number of days animals present,
- B_o = Maximum methane producing capacity (m^3/kg of VS) for manure produced by animal type i,
- MCF_{jk} = Methane conversion factor for each manure management system j by climate region k; and
- $MS\%_{ijk}$ = fraction of animal type i's manure handled using manure system j in climate region k.

The amount of methane emitted can be calculated using:

¹⁴ 2006 IPCC Guidelines for National Greenhouse Gas Inventories. Page 10.41 Equation 10.23 and Tables 10A-7 and 10A-8, p. 10.81 and 10.82

¹⁵ Obtained from 2006 IPCC, Annex 10A.2, Tables 10A-7 and 10A-8, p. 10.81 and 10.82



$$CH_{4a} = EF_i * Population_{year}$$

Equation E3¹⁶

Where:

- CH_{4a} = methane produced in kg/yr for animal type I,
 EF_i = emission factor (kg) for animal type i (e.g., swine),
 $Population_{year}$ = yearly average population of animal type i.

E.1.2.2 Describe the formulae used to estimate leakage due to the project activity, where required, for the applicable project category in appendix B of the simplified modalities and procedures for small-scale CDM project activities

In accordance with the baseline methodology, leakage calculations are not required.

E.1.2.3 The sum of E.1.2.1 and E.1.2.2 represents the small-scale project activity emissions:

To estimate total yearly methane emissions the selected emission factors are multiplied by the associated animal population and summed.

$$PE = [CH_{4a} + FE] * GWP_{CH4} / 1000$$

Equation E4¹⁷

Where:

- PE = Project activity carbon dioxide equivalent emission in metric tons per year,
 CH_{4a} = annual methane produced in kg/yr for animal type I,
 FE = annual methane emitted from flare due to inefficiency
 GWP_{CH4} = global warming potential of methane (21),

Table E2. Project Activity Emissions

¹⁶ Adapted from 2006 IPCC Guidelines for National Greenhouse Gas Inventories. Page 10.41.

¹⁷ Adapted from Equation 9, page 12, AM0016/version 02, 22 October 2004/UNFCCC/CDM Methodology Panel



Fazenda Alvorada (21932)								Year 1			
	Population_{year}	N_m	Days OB	Default BW	Ave Bw, kg	EF_i	CH₄ annual				
Sows:	0	365	0	198	215	6.37	0.00				
Gilts:	0	365	0	198	112	3.32	0.00				
Boars:	0	365	0	198	234	6.94	0.00				
Finishers:	3,468	365	0	46	68	4.69	16,248.11				
Nur/Wean:	0	365	0	46	15	1.03	0.00				
Digester CH ₄ :							16,248.11				
Direct Emissions (Flare) CH ₄ :							2,242.24				
Total Annual CH ₄ :							18,490.35				
PE (CO ₂ e/year):							388.30				

Fazenda Alvorada (21932)											
Year	1	2	3	4	5	6	7	8	9	10	Total
Expected Growth %	0%	2%	2%	2%	2%	2%	2%	2%	2%	2%	
Project Emissions (CO₂e/year)	388.3	396.1	404.0	412.1	420.3	428.7	437.3	446.0	455.0	464.1	4,251.7

Fazenda Alvorada (21952)								Year 1			
	Population_{year}	N_m	Days OB	Default BW	Ave Bw, kg	EF_i	CH₄ annual				
Sows:	0	365	0	198	215	6.37	0.00				
Gilts:	0	365	0	198	112	3.32	0.00				
Boars:	0	365	0	198	234	6.94	0.00				
Finishers:	3,468	365	0	46	68	4.69	16,248.11				
Nur/Wean:	0	365	0	46	15	1.03	0.00				
Digester CH ₄ :							16,248.11				
Direct Emissions (Flare) CH ₄ :							2,242.24				
Total Annual CH ₄ :							18,490.35				
PE (CO ₂ e/year):							388.30				

Fazenda Alvorada (21952)											
Year	1	2	3	4	5	6	7	8	9	10	Total
Expected Growth %	0%	2%	2%	2%	2%	2%	2%	2%	2%	2%	
Project Emissions (CO₂e/year)	388.3	396.1	404.0	412.1	420.3	428.7	437.3	446.0	455.0	464.1	4,251.7



Granja Adriana (28102)								Year 1			
	Population_{year}	N_m	Days OB	Default BW	Ave Bw, kg	EF_i	CH₄ annual				
Sows:	831	365	0	198	215	6.37	5,296.06				
Gilts:	211	365	0	198	112	3.32	700.51				
Boars:	11	365	0	198	234	6.94	76.30				
Finishers:	6,548	365	0	46	68	4.69	30,678.38				
Nur/Wean:	2,190	365	0	46	15	1.03	2,263.34				
Digester CH ₄ :							39,014.60				
Direct Emissions (Flare) CH ₄ :							5,462.04				
Total Annual CH ₄ :							44,476.64				
PE (CO ₂ e/year):							934.01				
Granja Adriana (28102)											
Year	1	2	3	4	5	6	7	8	9	10	Total
Expected Growth %	0%	0%	0%	0%	0%	0%	0%	0%	0%	0%	
Project Emissions (CO ₂ e/year)	934.0	934.0	934.0	934.0	934.0	934.0	934.0	934.0	934.0	934.0	9,340.1

E.1.2.4 Describe the formulae used to estimate the anthropogenic emissions by sources of GHGs in the baseline using the baseline methodology for the applicable project category in appendix B of the simplified modalities and procedures for small-scale CDM project activities:

Table E3. Baseline Emissions

Fazenda Alvorada (21932)								Year 1			
	Population_{year}	N_m	Days OB	Default BW	Ave Bw, kg	EF_i	CH₄ annual				
Sows:	0	365	0	198	215	50.35	0.00				
Gilts:	0	365	0	198	112	26.23	0.00				
Boars:	0	365	0	198	234	54.80	0.00				
Finishers:	3,468	365	0	46	68	37.01	128,360.07				
Nur/Wean:	0	365	0	46	15	8.16	0.00				
Total Annual CH ₄ :							128,360.07				
BE (CO ₂ e/year):							2,695.56				
Fazenda Alvorada (21932)											
Year	1	2	3	4	5	6	7	8	9	10	Total
Expected Growth %	0%	2%	2%	2%	2%	2%	2%	2%	2%	2%	
Baseline Emissions (CO ₂ e/year)	2,695.6	2,749.5	2,804.5	2,860.6	2,917.8	2,976.1	3,035.6	3,096.4	3,158.3	3,221.4	29,515.6



Fazenda Alvorada (21952)							Year 1	
	Population _{year}	N _m	Days OB	Default BW	Ave Bw, kg	EF _i	CH ₄ annual	
Sows:	0	365	0	198	215	50.35	0.00	
Gilts:	0	365	0	198	112	26.23	0.00	
Boars:	0	365	0	198	234	54.80	0.00	
Finishers:	3,468	365	0	46	68	37.01	128,360.07	
Nur/Wean:	0	365	0	46	15	8.16	0.00	
Total Annual CH ₄ :							128,360.07	
BE (CO ₂ e/year):							2,695.56	

Fazenda Alvorada (21952)											
Year	1	2	3	4	5	6	7	8	9	10	Total
Expected Growth %	0%	2%	2%	2%	2%	2%	2%	2%	2%	2%	
Baseline Emissions (CO ₂ e/year)	2,695.6	2,749.5	2,804.5	2,860.6	2,917.8	2,976.1	3,035.6	3,096.4	3,158.3	3,221.4	29,515.6

Fazenda Alvorada (21942)							Year 1	
	Population _{year}	N _m	Days OB	Default BW	Ave Bw, kg	EF _i	CH ₄ annual	
Sows:	0	365	0	198	215	50.35	0.00	
Gilts:	0	365	0	198	112	26.23	0.00	
Boars:	0	365	0	198	234	54.80	0.00	
Finishers:	3,468	365	0	46	68	37.01	128,360.07	
Nur/Wean:	0	365	0	46	15	8.16	0.00	
Total Annual CH ₄ :							128,360.07	
BE (CO ₂ e/year):							2,695.56	

Fazenda Alvorada (21942)											
Year	1	2	3	4	5	6	7	8	9	10	Total
Expected Growth %	0%	2%	2%	2%	2%	2%	2%	2%	2%	2%	
Baseline Emissions (CO ₂ e/year)	2,695.6	2,749.5	2,804.5	2,860.6	2,917.8	2,976.1	3,035.6	3,096.4	3,158.3	3,221.4	29,515.6

Fazenda Sao Tome (26842)							Year 1	
	Population _{year}	N _m	Days OB	Default BW	Ave Bw, kg	EF _i	CH ₄ annual	
Sows:	1,246	365	0	198	215	50.35	62,733.18	
Gilts:	0	365	0	198	112	26.23	0.00	
Boars:	0	365	0	198	234	54.80	0.00	
Finishers:	0	365	0	46	68	37.01	0.00	
Nur/Wean:	3,698	365	0	46	15	8.16	30,192.57	
Total Annual CH ₄ :							92,925.75	
BE (CO ₂ e/year):							1,951.44	



Granja Adriana (28102)							Year 1				
	Population _{year}	N _m	Days OB	Default BW	Ave Bw, kg	EF _i	CH ₄ annual				
Sows:	831	365	0	198	215	50.98	42,368.51				
Gilts:	211	365	0	198	112	26.56	5,604.08				
Boars:	11	365	0	198	234	55.49	610.40				
Finishers:	6,548	365	0	46	68	37.48	245,427.04				
Nur/Wean:	2,190	365	0	46	15	8.27	18,106.74				
Total Annual CH ₄ :							312,116.76				
BE (CO ₂ e/year):							6,554.45				
Granja Adriana (28102)											
Year	1	2	3	4	5	6	7	8	9	10	Total
Expected Growth %	0%	0%	0%	0%	0%	0%	0%	0%	0%	0%	
Baseline Emissions (CO ₂ e/year)	6,554.5	6,554.5	6,554.5	6,554.5	6,554.5	6,554.5	6,554.5	6,554.5	6,554.5	6,554.5	65,544.5

E.1.2.5 Difference between E.1.2.4 and E.1.2.3 represents the emission reductions due to the project activity during a given period:

The ex-ante baseline emissions calculated in section E.1.2.4 of this PDD will be compared to the actual monitored amount of methane captured and combusted by the project activity. The lesser of these values will be used as the project emission reductions of the crediting period.

$$ER_{net} = BE - (PE + DE)$$

Where:

- BE* = Baseline carbon dioxide equivalent emission in metric tons per year,
PE = Project activity carbon dioxide equivalent emission in metric tons per year,
DE = Direct emissions from use of fossil fuels or electricity for operation of facility



According to the methodology, direct emissions from the use of fossil fuels and/or electricity for the operation of the facility must be considered as part of the project emissions. For swine farms in Brazil, a standard equipment configuration consists of one 2 horsepower (HP) biogas blower that operates 24 hours per day per anaerobic digester.

$$\text{HP to kWh conversion} = \text{HP (2)} \times \text{hours per day (24)} \times \text{days a year (365)} \times 0.7457^{18}$$

As such, the electrical consumption per year per anaerobic digester for a swine farm in Brazil is approximately 13,065 kWh/yr. To convert this number into metric tonnes of CO₂e per year, the following formulae is applied:

$$\text{kWh to CO}_2\text{e conversion} = (\text{kwh (13,065)} \times \text{country specific emission factor (0.2677)}^{19}) / 1000$$

Therefore, for each anaerobic digester, approximately 3.5 metric tonnes of CO₂e are produced per year as a result of the project activity.

For this particular project with seven project activity sites and a corresponding seven anaerobic digesters, the totals are as follows:

Source	Est kWh consumed / produced per year	Kg CO ₂ e emitted per kWh produced	Metric Tonnes CO ₂ e per year
Direct emissions from use of electricity or fossil fuel	91,453	0.2677	24.48

Because the digester is a sealed system, all methane is captured and flared, leaving none to be released to the atmosphere via physical leakage. In addition, the methane conversion factor of the emission reduction calculations include a conservative 10% discount to compensate for intrinsic digester emissions.

Table E4. Total Emission Reductions

Table E4. Total Emission Reductions										
Year	1	2	3	4	5	6	7	8	9	10
Total Baseline Emissions (BE)	19,231	19,393	19,558	19,726	19,898	20,073	20,252	20,434	20,619	20,809
Total Project Emissions (PE)	2,760	2,783	2,807	2,831	2,856	2,881	2,907	2,933	2,960	2,987
Direct emissions from electricity/fossil fuel (DE)	24	24	24	24	24	24	24	24	24	24
Total Emission Reductions (ER _{net} = BE - (PE + DE))	16,447	16,585	16,726	16,870	17,017	17,167	17,320	17,476	17,635	17,797

¹⁸ .7457 is the standard scientific conversion factor from horsepower (HP) to Kilowatt Hours (kWh) based on Ohm's Law

¹⁹0.2677kg CO₂ / kWh, Obtained and calculated ex-ante from AMC002 and registered CDM project 0190. (Consumed by Project Activity Equipment based on design)

**E.2 Table providing values obtained when applying formulae above:****Table E5**

Parameter/Factor	Value	Source/Comment
Baseline		
GWP CH ₄	21	Intergovernmental Panel on Climate Change, <i>Climate Change 1995: The Science of Climate Change</i> (Cambridge, UK: Cambridge University Press, 1996)
Population _{year}	Table E1	Animal population used to estimate baseline and project emission estimates was based on a 12 month period of actual or projected operation production data.
n _m	Table E1	Days resident in system
MS% _{ijk}	100%	Percent of effluent used in system.
VS _{i, market}	0.27	Obtained from 2006 IPCC, Annex 10A.2, Table 10A-7, p. 10.81
VS _{i, breeding}	0.50	Obtained from 2006 IPCC, Annex 10A.2, Table 10A-8, p. 10.82
B _{oi}	0.48	Obtained from 2006 IPCC, Annex 10A.2, Tables 10A-7 and 10A-8, p. 10.81 and 10.82
MCF _{jk}	Table 10.17	Obtained from 2006 IPCC, Table 10.17, p. 10.46
Project Activity		
GWP CH ₄	21	Intergovernmental Panel on Climate Change, <i>Climate Change 1995: The Science of Climate Change</i> (Cambridge, UK: Cambridge University Press, 1996)
Population _{year}	Table E1	Animal population used to estimate baseline and project emission estimates was based on a 12 month period of actual or projected operation production data.
n _m	Table E1	Days resident in system
MS% _{ijk}	100%	Percent of effluent used in system
VS _{i, market}	0.27	Obtained from 2006 IPCC, Annex 10A.2, Table 10A-7, p. 10.81
VS _{i, breeding}	0.50	Obtained from 2006 IPCC, Annex 10A.2, Table 10A-8, p. 10.82
B _{oi}	0.48	Obtained from 2006 IPCC, Annex 10A.2, Tables 10A-7 and 10A-8, p. 10.81 and 10.82
MCF _{jk}	Table 10.17	Obtained from 2006 IPCC, Table 10.17, p. 10.46



Table E6

Uncertainty Parameter for GHG Mitigation Project Estimates	
Uncertainty:	How Addressed:
<ul style="list-style-type: none"> ○ Data collection inaccuracies ○ Animal type ○ Animal population, group/type, mortality rates ○ Genetics ○ Choice of appropriate emission coefficients ○ Data security ○ Animal health ○ Flare efficiency 	<ul style="list-style-type: none"> ○ Accurate data collection is essential. The farms included in this project activity use a Standardized industry database package which captures a wide range of incremental production data to manage operations and enable the farm to maximize both productivity and profitability. AgCert uses some data points collected via this system. ○ AgCert has a rigorous QA/QC system that ensures data security and data integrity. AgCert performs spot audits data collection activities. ○ AgCert has a data management system capable of interfacing with producer systems to serve as a secure data repository. Project activity data related uncertainties will be reduced by applying sound data collection quality assurance and quality control procedures. ○ Any significant mortality rates will be visible from the Monthly Monitoring Form and addressed accordingly. ○ The monitoring plan addresses emergency operating procedures.

SECTION F.: Environmental impacts:

F.1. If required by the host Party, documentation on the analysis of the environmental impacts of the project activity:

An environmental impact analysis is not required for this type of GHG project activity.

Environment:

There are no negative environmental impacts resulting from the proposed project activity.

Beyond the principal benefit of mitigating GHG emissions (the primary focus of the proposed project); the proposed activities will also result in positive environmental co-benefits. They include:

- Reducing atmospheric emissions of Volatile Organics Compounds (VOCs) that cause odour,
- Lowering the population of flies and associated enhancement to on-farm bio-security thus reducing the possible spread of disease.

The combination of these factors will make the proposed project site more “neighbour friendly” and environmentally responsible.

**SECTION G. Stakeholders' comments:****G.1. Brief description of how comments by local stakeholders have been invited and compiled:**

Stakeholders meetings for this project activity were held in Goiânia, Goiás on January 26, 2005 and December 6, 2005 and in Cuiaba, Mato Grosso on December 12, 2005.

AgCert invited stakeholders to the meetings to explain the UNFCCC CDM process and proposed project activity, presided over by Paulo Furtado in Minas Gerais and Oldemar Eichelt in Mato Grosso.

Invitations were sent via electronic mail and postal directly to project participants, federal, state and local officials prior to the meetings.

The CDM Project Stakeholders Meeting information was published in the municipal newspaper in the region of the CDM project activity:

- a) *O Mercador*, Rio Verde, January 18, 2005
- b) *O Popular*, Goiânia, December 2, 2005
- c) *Folha do Estado*, Cuiaba, December 7, 2005

A slide presentation was given, in Portuguese, and attendees were afforded the opportunity to ask questions and provide comments. On other occasions, representatives from AgCert also met with and explained project details to local and state government officials.

Minutes for these meetings have been compiled and include questions and answers for each of the meetings.

G.2. Summary of the comments received:

No negative issues were raised by local stakeholders. Comments voiced by individuals were positive and supporting of the project activity.

A complete listing of the comments and the individuals who made them is on file. The above comments were translated into English by AgCert.

G.3. Report on how due account was taken of any comments received:

Overall, there was good feedback from all participants about the project activity. The group pledged their support and offered to assist if needed in the facilitation and completion of the project. Several stakeholders voiced their appreciation for having the opportunity to participate in these project activities.

**Annex 1****CONTACT INFORMATION ON PARTICIPANTS IN THE PROJECT ACTIVITY**

Project Participant and Developer:	
Organization:	Agcert do Brasil Soluções Ambientais Ltda.
Street/P.O. Box:	Rua James Joule, 92, 14th andar
Building:	
City:	Cidade Monções
State/Region:	São Paulo
Postfix/ZIP:	04576-080
Country:	Brasil
Telephone:	+55 11 2127.0450
FAX:	+55 11 2127.0550
E-Mail:	
URL:	www.Agcert.com
Represented by:	David Lawrence
Title:	Project Coordinator
Salutation:	
Last Name:	Lawrence
Middle Name:	
First Name:	David
Department:	
Mobile:	+55 11 8412-3206
Direct FAX:	
Direct tel:	
Personal E-Mail:	dlawrence@agcert.com



Annex 2

INFORMATION REGARDING PUBLIC FUNDING

There is no official development assistance being provided for this project.



Annex 3

Monitoring Plan

PURPOSE

The purpose of this method specification is to describe the criteria for maintaining equipment, reporting equipment outages, and to provide detailed guidance for collection and processing of data that is used in the determination of Green House Gas (GHG) emissions.

SCOPE

This document applies to GHG Mitigation Project related activities. It applies to all personnel that operate and/or maintain project activity equipment and/or have an active role in data collection and processing.

ASSOCIATED DOCUMENTS

- UNFCCC approved monitoring methodology: AMS-III.D., Methane Recovery.
http://cdm.unfccc.int/UserManagement/FileStorage/CDMWF_AM_LM875Z64MVHWOE3JVL4BG_GIC4SRUBE
- Jody Zall Kusek, and Ray C. Rist, June 2004. Ten Steps to a Results-based Monitoring and Evaluation System: A Handbook for Development Practitioners, World Bank.
http://www.worldbankinfoshop.org/ecommerce/catalog/product?item_id=3688663
- Component guides / manuals for:
 - Manure transfer system
 - Anaerobic digester
 - Biogas transfer system including a biogas flow-meter
 - Combustion system (Flare)
 - Optional combustion system
- MS004-F1, O & M Weekly Monitoring Checklist
- MS004-F2, O & M Monthly Monitoring Form
- MS004-F3, O & M Maintenance Log (en-br)
- MS004-F4, O & M Maintenance Log (sp-mx)
- MS008, Farm Data Collection Procedure
- MS008-F1, Animal Inventory Control



- MS008-F2, Monthly Inventory Reporting
- P004, Control of Nonconforming Product/Service
- P020, Monitoring & Measurement of Product/Processes
- P025, Control of Monitoring & Measurement Devices
- I025-1, Equipment Calibration & Verification
- P039, Competence, Training, and Awareness
- I031-2F11, Form B – Swine – IPCC (en)
- I031-2F13, Form B – IPCC – MX (sp)
- I031-2F16, Form B – Dairy – IPCC (en), (sp), (pt)
- I036-9, Bio-security and Safety
- Operations Manual **CO₂ Gas** Analyzer
- EnviroCert Operations Management System (OMS)

OPERATION AND MAINTENANCE ACTIVITIES

System Overview

The Animal Waste Management System (AWMS) used in this project is shown in Figure 1. The system is made up of four (4) major system components:

- Manure transfer system which includes one lift station if needed
- Anaerobic digester cell(s)
- Biogas transfer system including a biogas flow-meter
- Combustion system (Flare)
- Optional combustion system

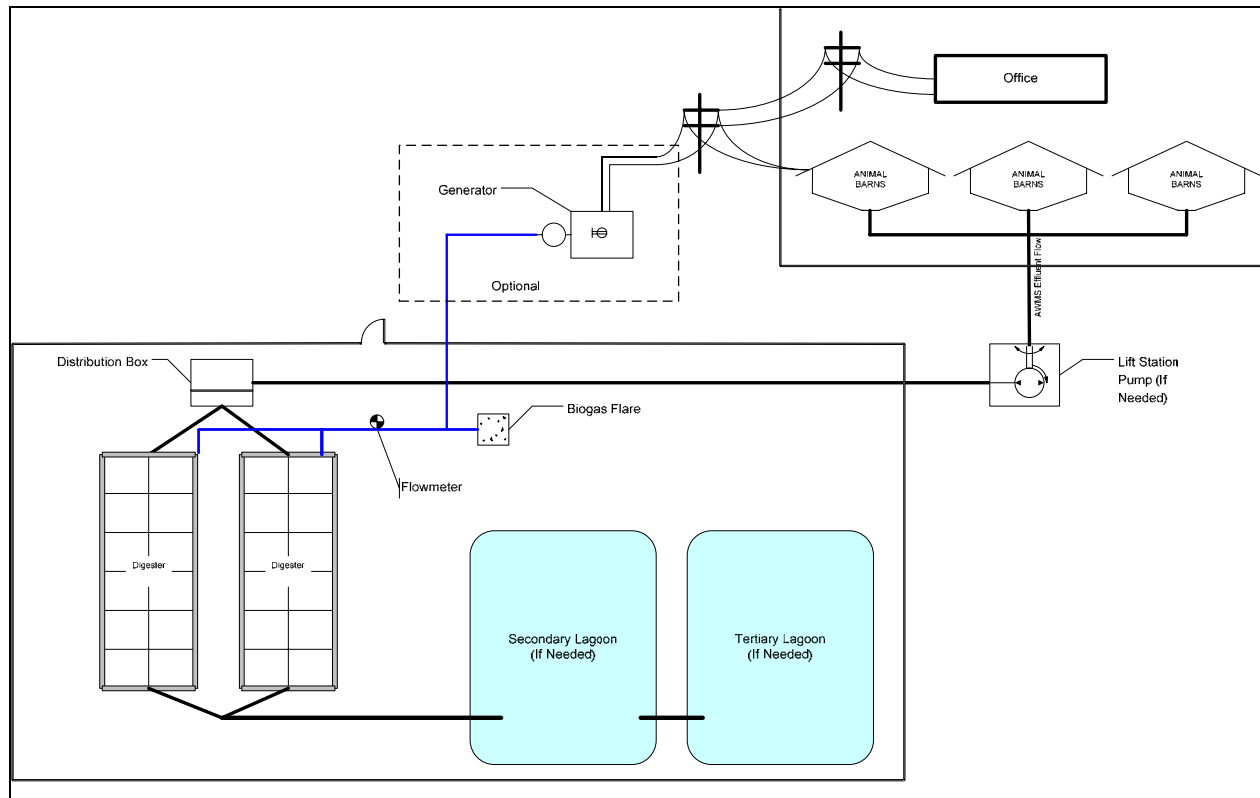

Figure 1. Typical GHG Mitigation Project System Overview

System Components Operation Requirements

Manure Transfer System

Training

Training on the Manure Transfer System shall be provided to the operations personnel by the system manufacturer and installer. Training shall include: system components, normal operation, emergency operations, maintenance, and request for warranty service. Training on reporting procedures shall be provided to the productions operations manager by AgCert.

Normal Operation

The system described in Figure 1 is a typical flush system with one optional lift station. Under normal conditions, farm hands clean the manure from the barns using water hoses and squeegees. This effluent is captured and then flushed from the barns periodically. Effluent from the barns is deposited in a lift station. Upon reaching predetermined threshold, the pump engages and routes the effluent to the digester cell. Upon being treated in the digester, the effluent is then routed from the digester to the storage lagoon. Liquid from the lagoon can then be used for irrigation.

Safety Issues and Emergency Preparedness



Care should be exercised when working around the lift station and distribution box (if installed) to avoid falling into the pit.

Weekly Inspection

A periodic inspection shall include the following:

- Check for pipeline obstructions
- Check for leaks in exposed pipelines
- Check for corrosion at exposed joints

Alternative Operating Procedures

In the event the manure transport system becomes unusable, the farm manager shall notify AgCert in accordance with the Emergency Maintenance section of this annex. Both parties shall work together to reach an acceptable alternate method to route the effluent so that farm operations are not affected, and GHG continues to be captured. If maintenance or warranty service is required, AgCert shall contact the appropriate service provider. Upon restoration of the system the farm manager shall notify the Regional Maintenance Technician (RMT) (phone, e-mail, etc.).

Anaerobic Digester

WARNING

The gas contained in the digester cell is EXTREMELY flammable. Sources of ignition and smoking are not permitted within 10 meters of the cell and gas handling system.

Death or serious injury may result.

Training

Training on the Ambient Temperature Anaerobic Digester shall be provided to production operations personnel by the system manufacturer and installer. Training shall include: system components, start-up procedures, normal operation, emergency operations, maintenance, and request for service. Training on reporting procedures shall be provided to the productions operations personnel by AgCert.

Startup Procedures

Refer to the guide / manual for the ambient temperature anaerobic digester.

Loading Rate and Total Solids Content

Refer to the guide / manual for the ambient temperature anaerobic digester.

Normal Operation

Refer to the guide / manual for the ambient temperature anaerobic digester.

Safety Issues and Emergency Preparedness

- No open flame permitted within 10 meters of the digester
- Do not allow personnel to stand, sit, or lean against the digester cover
- Do not use sharp objects/tools in the vicinity of the cover

Weekly Inspection

A weekly inspection shall include the following:

- Cover material – check for cracks, tears, or points of distress around perimeter of digester cell.
- Check for excessive ballooning of cover or presence of odor
- Check seams for signs of gas leakage

Alternative Operating Procedures

In the event the digester cell becomes unusable, the farm manager shall notify AgCert in accordance with paragraph 0. Both parties shall work together to reach an acceptable alternate method to treat the effluent so that farm operations are not affected, and GHG gas continues to be captured. If maintenance or warranty service is required, AgCert shall contact the appropriate service provider. Upon restoration of the system the Regional Maintenance Technician shall be notified (phone, e-mail, etc.).

Biogas Transfer System and Biogas Sensor/Flow-Meter

Training

Training on the Biogas Transfer System shall be provided to the operations personnel by the system manufacturer and installer. Training shall include: system components, normal operation, emergency operations, maintenance, and request for warranty service. Training on reporting procedures shall be provided to the production operations personnel by AgCert.

Normal Operation

Biogas produced in the anaerobic digester is trapped under a positive or negative pressure geomembrane cover installed over the digester cell. The biogas is routed from the digester to the flare via PVC tubing. A flow meter, which measures gas flow, is fitted in the biogas transfer system piping.



Figure 2. Roots biogas flowmeter

Safety Issues and Emergency Preparedness

Gas to the metering system should be disconnected prior to performing maintenance on the flow-meter. Care should be taken when digging in the area where the pipeline is buried.

Preventive Maintenance

Preventive maintenance shall be conducted in accordance with manufacturer's recommendations. NOTE: A record of the cumulative biogas reading must be recorded prior to zeroing the meter.



Weekly Inspection

The weekly inspection shall include the following:

- Check for leaks in exposed pipelines
- Check for proper operation of the flow-meter

Alternative Operating Procedures

In the event that the biogas transfer system becomes unusable; the farm manager shall **immediately** notify AgCert in accordance with the Emergency Maintenance section of this annex. Both parties shall work together to reach an acceptable alternate method to route the biogas so that farm operations are not affected and GHG gas emissions are mitigated. If maintenance or warranty service is required, AgCert shall contact the appropriate service provider. Upon restoration of the system the RMT shall be notified (phone, e-mail, etc.).

Combustion System (Flare)

Training

Training on the Flare Combustion System shall be provided by the system manufacturer and installer. Training shall include: system components, normal operation, emergency operations, maintenance, and request for warranty service. Training on reporting procedures shall be provided to the production operations personnel by AgCert.

Normal Operation

The flare system is designed to combust the biogas whenever it is present. AgCert's flaring combustion system is automated to ensure that all biogas that exits the digester and passes through the flare (and flow meter) is combusted. Pressure control devices within the gas handling system maintain proper biogas flow to the combustion system. A continuous ignition system ensures methane combustion whenever biogas is present at the flare. The continuous ignition system is powered by a robust solar module (solar-charged battery system) that operates independently from the power grid. These solar modules are designed for rigorous outdoor application in remote locations and are proven through many years of operational experience in ranch and farm settings similar to AgCert project sites. Two (2) sparking electrodes provide operational redundancy to ensure that a minimum of one (1) spark is produced at the flare burner every 3 seconds. If biogas is present in the flare, it is immediately ignited by the sparking system. If biogas is not present, the igniter sparks harmlessly.

Safety Issues and Emergency Preparedness

Prior to performing any maintenance on the flare system, the gas flow **must** be turned off. Care should be exercised when working around the flare system as components can be extremely hot.

Preventive Maintenance

Preventive maintenance shall be conducted at least yearly.

Weekly Inspection

The weekly inspection shall include a visual inspection to determine the flare is combusting gas.

- If no flame is visible, check to see if there is a heat signature or if the flare assembly itself is hot. Night time inspection should reveal a visible light from the unit.



Alternative Operating Procedures

In the event that the flare system becomes unusable, the farm manager shall **immediately** notify AgCert in accordance with the Emergency Maintenance section of this annex. Both parties shall work together to reach an acceptable alternate method to combust the biogas so that farm operations are not affected and GHG emissions are mitigated. If maintenance or warranty service is required, AgCert shall contact the appropriate service provider. Upon restoration of the system the RMT shall be notified (phone, e-mail, etc.).

Optional Combustion System

If optional combustion equipment is installed during the project crediting period, the project developer will submit a change to the registered monitoring plan as required by the UNFCCC Secretariat.

Training

Training on any optional combustion system, e.g., generator, space heater, etc., shall be provided by the system manufacturer and installer. Training shall include: system components, normal operation, emergency operations, maintenance, and request for warranty service. Training on reporting procedures shall be provided to the production operations personnel by AgCert.

Normal Operation

An optional combustion system is designed to take advantage of the biogas and convert it into renewable energy. The systems can be used to generate electricity, heat a barn, or any other process approved (in writing) by AgCert and the verifying designated operational entity (DOE).

Safety Issues and Emergency Preparedness

Prior to performing any maintenance on an optional combustion system, the gas flow **must** be turned off. Care should be exercised when working around the optional combustion system as components can be extremely hot and high voltage may be present (when operating).

Preventive Maintenance

Preventive maintenance shall be conducted in accordance with manufacturer's recommendations. NOTE: In any case where it is required to zero and/or remove a meter, ensure that the meter reading is noted prior to zeroing and/or removing the meter.

Alternative Operating Procedures

In the event that the generator system becomes unusable, the user shall notify AgCert in accordance with paragraph 0. The flare shall be used as the only method to combust GHG biogas. The user shall take appropriate action to notify his service provider should maintenance or warranty service be required. Upon restoration of the system the RMT shall be notified (phone, e-mail, etc.).

Maintenance, Trouble Reporting and Documentation

Emergency Maintenance:

Situations requiring immediate attention due to failure of components of the digester or combustion system that could cause significant damage to the physical structure, or could result in the release of GHG or failure to capture GHG should be immediately reported to the Regional Maintenance Technician. If



unavailable, contact the National Monitoring or Maintenance Manager of the country where the equipment is located or the International Operations and Maintenance Manager.

Title	Phone	e-mail
Regional Maintenance Technician (RMT)	Supplied during training	Supplied during training
Argentina National Monitoring Manager	(54) 348-844-6127	operationsar@agcert.com
Brazil National Monitoring Manager	(55) 212-704-50 ext 0490	operationsbr@agcert.com
Chile National Monitoring Manager	(56) 222-911-52	operationscl@agcert.com
International Monitoring Manager	(001) 321-409-7846	operations@agcert.com
Mexico National Monitoring Manager	(52) 552-122-0310	operationsmx@agcert.com
Canada National Monitoring Manager	(001) 780-409-9286	n/a

Unscheduled Maintenance:

Situations requiring maintenance (not resulting in the release or failure to capture GHG) should be reported to the Regional Maintenance Technician, normally within 1 to 24 hours of discovery.

Records Keeping

Maintenance and servicing of equipment shall be recorded.

MONITORING ACTIVITIES

The following table summarizes key parameters monitored:

**Table 1. Key parameters monitored**

ID	Item	Applies to Project	Monitored		ER Calculation Data		Performed by	Comments
			Ex-ante	Ex-post	Primary	Secondary		
1	Sludge Removal (SIR)	✓		✓			RMT	Ensures proper disposition of sludge
2	Biogas Produced (BGP)	✓		✓		✓	FH, RMT	QA/QC
3	Methane Content (MC)	✓		✓		✓	RMT	If significant deviations are observed, more frequent measurements will be taken until the values stabilize.
4	Combustion System Operational Time (CEE)	✓		✓	✓		FH, RMT	Whenever the flare is observed to be out of service, any biogas metered from the last known operational point in time, shall be deducted from the total Biogas reading
5	Efficiency of Flare process (EFP)	✓		✓			EN	Ensures correct performance of combustion

Farm: FH – Farm Hand; DP – Data Processor; FM – Farm Manager;
AgCert: RMT – Regional Maintenance Technician, QA – Quality Assurance; OP – Operations, EN - Engineer

MONITORING WORK INSTRUCTIONS

Work instructions for the monitoring of key parameters can be found on the following pages:

Work Instruction for monitoring ID 1, Sludge Removal,**Summary**

Due to the physical characteristics of the manure, it becomes necessary at times to remove the sludge that has accumulated inside a biodigester. This helps ensure the digester system is operating nominally. It is important to ensure the removed sludge is disposed of properly.



This ID monitors the number of times sludge is removed from the digester and ensures the sludge is disposed of properly.

References

- AgCert Preventive Maintenance Instruction GM001, Biodigester Sludge, Removal and Disposal Instruction
- UNFCCC approved monitoring methodology: AMS-III.D, Ver 11., Methane Recovery.

Prerequisite(s)

Processes

- I036-9, Bio-security and Safety

Training of Monitoring Personnel

- Regional Monitoring Technicians shall be trained on data collection transfer processes.
- Operations personnel shall be trained on proper disposition practices.

Equipment, Materials and Tools

- GM001, Biodigester Sludge Removal and Disposal Instruction
- GM001-F1, Sludge removal record

Calibration

- None

Process

Step	Operator	Activity	Documentation	Comments
1	RMT	Determine need to remove sludge		Sludge is disposed of by applying to soil or some other aerobic process
2	RMT	Coordinate with Maintenance to schedule sludge removal	Electronic	
3	M	Performs sludge removal in accordance with the PMI		
4	M	Properly dispose of sludge		
5	M	Document disposal method on maintenance form	Paper/electronic	

Farm: FH – Farm Hand; DP – Data Processor; FM – Farm Manager;
 AgCert: RMT – Regional Maintenance Technician, QA – Quality Assurance; OP – Operations, EN – Engineer, M - Maintenance



RECORD ID	RECORD LOCATION	RETENTION TIME	DISPOSITION
GM001-F1	EnviroCert	Duration of project +2 years	Destroy

Work Instruction for monitoring ID 2, Biogas Produced

Summary

This ID monitors the volume and flow of biogas sent to the combustion system on a monthly basis. It is a quality control check to ensure proper operation of the anaerobic digester.

References

- UNFCCC approved monitoring methodology: AMS-III.D., Ver 11., Methane Recovery.
- Data collection forms (provided by farm manager)
- P025, Control of Monitoring and Measuring Device (MMD)
- MS004-F2, O & M Monthly Monitoring Form

Prerequisite(s)

Processes

- I036-9, Bio-security and Safety

Training of Monitoring Personnel

- Regional Maintenance Technicians and operations personnel shall be trained on data collection transfer processes.

Equipment, Materials and Tools

- Biogas Flow Meter

Calibration

- Prior to using a measuring device, ensure it is calibrated.



Process

Step	Operator	Activity	Documentation	Comments
1	RMT	Record reading in appropriate area of MS004-F2, Monthly Monitoring Form	MS004-F2, Monthly Monitoring Form	
2	RMT	Transmit data to MLB operations	Fax, Electronic, etc	Enter data into EnviroCert
3	QA	Perform Quality Control Check for format, integrity, etc.		
4	OP	Confirm reading within expected limits IAW manufacturer guidelines.		
5	OP	Store Data		
Farm: FH – Farm Hand; DP – Data Processor; FM – Farm Manager; AgCert: RMT – Regional Monitoring Technician, QA – Quality Assurance; OP – Operations, EN – Engineer				

Records Control

RECORD ID	RECORD LOCATION	RETENTION TIME	DISPOSITION
MS004-F2, Monthly Monitoring Form	Document Control Center	Duration of project + 2 years	Destroy

Work Instruction for monitoring ID 3, Methane Content

Summary

This ID determines the methane content of the biogas. It is a snapshot of the AMWS methane production efficiency. Methane concentration is determined with CO²-content measurement and is obtained with a gas analyzer. A range of ± 10% points is sufficient to determine uncertainties. For example, the nominal percentage of CH₄ in biogas is approximately 65%. Readings between 55% and 75% indicate proper operation of the digester. The measuring equipment is calibrated in accordance with the manufacturer specifications. This ID determines the methane content of the biogas. It is a snapshot of the AMWS methane production efficiency. Methane concentration is determined with a gas analyzer. The measuring equipment is calibrated in accordance with the manufacturer specifications.



References

- UNFCCC approved monitoring methodology: AMS-III.D., Methane Recovery
- P025, Control of Monitoring and Measuring Device (MMD)
- Operations Manual **CO₂ gas** Analyzer
- MS004-F2, Monthly Monitoring Form
- MS004-F3 or F4, O & M Maintenance Log

Prerequisite(s)

Processes

- I036-9, Bio-security and Safety

Training of Monitoring Personnel

- Operating the **CO₂ gas** Analyzer
- Regional Maintenance Technicians shall be trained on data collection transfer processes.
- Operations personnel shall be trained on data processing and storage

Equipment, Materials and Tools

- **CO₂ Gas** Analyzer

Calibration

- As required by the manufacturer.

Process

Step	Operator	Activity	Documentation	Comments
1	RMT	Prepare the gas analyzer as directed in the operator manual.	CO₂ Gas Analyzer Operations Manual	
2	RMT	Connect the CO₂ gas analyzer to the system test port.		
3	RMT	Open valve on test port		
4	RMT	Take gas reading in accordance with Operations Manual		Take 5 readings and average the results.
5	RMT	Record CO₂ gas readings in appropriate spaces of MS004-F2, Monthly Monitoring Form	MS004-F2, Monthly Monitoring Form	If there is greater than 10% points difference from previous reading, initiate appropriate maintenance actions and continue to measure on a monthly basis until the readings stabilize.



Step	Operator	Activity	Documentation	Comments
6	RMT	Close valve on test port		
7	RMT	Disconnect hose in reverse order of connection		
8	RMT	Double check that biogas test port valve is closed prior to leaving area		
9	RMT	Transmit data to MLB operations	Fax, Electronic, etc	Enter into EnviroCert
10	QA	Perform Quality Control Check for format, integrity, etc.		
11	OP	Confirm reading within expected limits IAW manufacturer guidelines.		
12	OP	Store Data		

Farm: FH – Farm Hand; DP – Data Processor; FM – Farm Manager;
AgCert: RMT – Regional Monitoring Technician, QA – Quality Assurance; OP – Operations, EN - Engineer

Records Control

RECORD ID	RECORD LOCATION	RETENTION TIME	DISPOSITION
MS004-F2, Monthly Monitoring Form	Document Control Center	Duration of project + 2 years	Destroy

Work Instruction for monitoring ID 4, Fraction of time Combustion Equipment Operates

Summary

This parameter is used to determine the fraction of time in which gas is combusted. The fraction of time will be determined as 100% less any time the flare is out of service and gas is flowing. Flare maintenance records will be used to make this determination.

References

- UNFCCC approved monitoring methodology: AMS-III.D., Methane Recovery
- MS004-F2, O & M Monthly Monitoring Form
- P025, Control of Monitoring and Measuring Device (MMD)



Prerequisite(s)

Processes

- I036-9, Bio-security and Safety

Training of Monitoring Personnel

- Regional Maintenance Technicians and operations personnel shall be trained on data collection transfer processes.

Equipment, Materials and Tools

Calibration

- Prior to using a measuring device, ensure it is calibrated.

Process

Step	Operator	Activity	Documentation	Comments
1	RMT	Record reading in appropriate area of MS004-F2, Monthly Monitoring Form	MS004-F2, Monthly Monitoring Form	
2	RMT	Transmit data to MLB operations	Fax, Electronic, etc	Enter data into EnviroCert
3	QA	Perform Quality Control Check for format, integrity, etc.		
4	OP	Confirm reading within expected limits IAW manufacturer guidelines.		
5	OP	Store Data		
Farm: FH – Farm Hand; DP – Data Processor; FM – Farm Manager; AgCert: RMT – Regional Maintenance Technician; QA – Quality Assurance; OP – Operations, EN - Engineer				

RECORD ID	RECORD LOCATION	RETENTION TIME	DISPOSITION
MS004-F2, Monthly Monitoring Form	Document Control Center	Duration of project + 2 years	Destroy



Records Control

Work Instruction for monitoring ID 5, Flare Efficiency

Summary

This parameter guarantees the correct performance of digester and gas recovery.

References

- Approved monitoring methodology: AMS-III.D., Methane Recovery.
- P025, Control of Monitoring and Measuring Devices
- MS004-F2, O & M Monthly Monitoring Form
- OM002, Flare Efficiency Test Instruction
- OM002-F1, Flare Efficiency Test Table

Prerequisite(s)

Processes

Efficiency is tested prior to installation and amount of methane combusted is calculated based on the efficiency rating. According to the methodology, the flare efficiency shall be calculated as fraction of time the gas is combusted in the flare multiplied by the efficiency of the flaring process.

The enclosed flaring combustion system is automated to ensure that all biogas that exits the digester and passes through the flare (and flow meter) is combusted. Pressure control devices within the gas handling system maintain proper biogas flow to the combustion system. A continuous ignition system ensures methane combustion whenever biogas is present at the flare. Two (2) sparking electrodes provide operational redundancy. If biogas is present in the flare, it is immediately ignited by the sparking system. If biogas is not present, the igniter sparks harmlessly. This continuous ignition system is powered by a robust solar module (solar-charged battery system) that operates independently from the power grid. The component parts are tested and verified functional on a periodic basis in accordance with manufacturer and other technical specifications.

A flare efficiency test will be performed for each new flare that is installed at an AgCert digester project site. Initial flare efficiency testing will be performed by trained personnel using calibrated equipment and a third-party verified test protocol. Both methane destruction determinations described in the flare efficiency testing protocol will be performed during the initial flare testing to ensure that the flare performs according to specifications. Results of the initial flare efficiency test will be kept on project file and will be made available to the verifying Designated Operational Entity (DOE). Subsequent operational testing shall be accomplished at least yearly using the verified test protocol.

Equipment, Materials and Tools

- Gas analyzer (a Landtec GA-90, GEM-500 or equivalent).



Calibration

- Prior to using a measuring device, ensure it is calibrated.

Process

Step	Operator	Activity	Documentation	Comments
1	EN	Perform procedures outlined in OM002.	OM002-F1, Flare Efficiency Test Table	
Farm: FH – Farm Hand; DP – Data Processor; FM – Farm Manager; AgCert: RMT – Regional Monitoring Technician, QA – Quality Assurance; OP – Operations, EN - Engineer				

Records Control

RECORD ID	RECORD LOCATION	RETENTION TIME	DISPOSITION
• OM002-F1, Flare Efficiency Test Table	EnviroCert	Duration of Project +2 years	Destroy

EMISSION REDUCTION CALCULATIONS**Calculating Methane (CH₄) Emissions**

Step 1: Record biogas meter reading (ID2).

Step 2: Record the percentage of methane of the biogas (ID3).

Step 3: Multiply ID 2 and ID 3.

Step 4: Multiply ID4 and ID5.²⁰

Step 5: Multiply the result of Step 3 and Step 4

²⁰ For the purposes of estimating ERs, the value of 98% was used based on EPA studies on flaring processes for the same type of enclosed flare used in this project:

<http://www.epa.gov/cmop/pdf/022red.pdf#search=%22EPA%20enclosed%20flare%20efficiency%22>



Annex 4

Control of Measuring & Monitoring Devices (MMD)

PURPOSE

The purpose of this document is to ensure that all MMD's used to demonstrate product conformity with specified requirements is identified, controlled and gauged at prescribed frequencies and that records for these activities are kept.

SCOPE

This document applies to all MMD's as well as software, used to verify product conformity with specified requirements. It applies to all individuals responsible for the selection, maintenance, and use of MMD's.

ASSOCIATED DOCUMENTS

MS004, O & M Manual
P005, Corrective and Preventative Action

DEFINITIONS

OM:	Operations and Maintenance
OPS:	Operations
QA:	Quality Assurance
RMT:	Regional Maintenance Technician
SUP:	MMD Supplier



PROCEDURE

	Responsibilities	Associated Documents
1 Identify the need for measuring and/or monitoring devices/software	OM, OPS, QA, SUP	A
↓		
2 Determine type of equipment based on required accuracy	OM, QA, SUP	A
↓		
3 Upon purchase and/or installation, initiate record for equipment.	OM, OPS, RMT, SUP	A
↓		
4 Establish frequency and calibration method or verification activity	OM, QA, SUP	A
↓		
5 Correct any “Out of Tolerance” conditions.	OM, RMT, SUP	A, B

NOTES

- BOX 1. OM, OPS, and QA, together with SUP shall identify MMD’s/Software that will be used to monitor equipment performance.
- BOX 2. MMD’s/Software will be selected/designed as best suited to ensure proper performance. Determination of MMD’s/Software required shall be based on the measurements to be taken and the accuracy required.
- BOX 3. Calibrated Devices will be labeled at a minimum with a unique identification number, status of calibration and date next calibration due. Records will be maintained that show the actual state of each piece of equipment, physical conditions of calibrating equipment and actual



readings obtained from calibration and/or verification. Records will be maintained in accordance with section 7.0 Record Control.

BOX 4. Off-the-shelf equipment will be calibrated in accordance with the SUP recommended calibration cycle.

Custom-gauged equipment calibration intervals shall be defined by OM & SUP. The calibration intervals can be adjusted based on the analysis of previous calibration results and at the discretion of OM & SUP.

Third Party Calibration Service will be managed as if activity was performed by company personnel. This will include requirement that all Qualifying Certifications and references to NIST Standards be submitted/maintained.

BOX 5. Devices found to be out of tolerance will be adjusted/repaired. An investigation will be conducted to determine the effect that the out of tolerance condition may have had on the ability to verify conformance of product to customer requirements and to determine what action, if any, should be taken.

RECORD CONTROL

RECORD ID	FILE LOCATION	RETENTION TIME	DISPOSITION
Equipment calibration records	Site of use	1 year after equipment has been removed from service	Destroyed