

01/2006

613N 591N

HFO

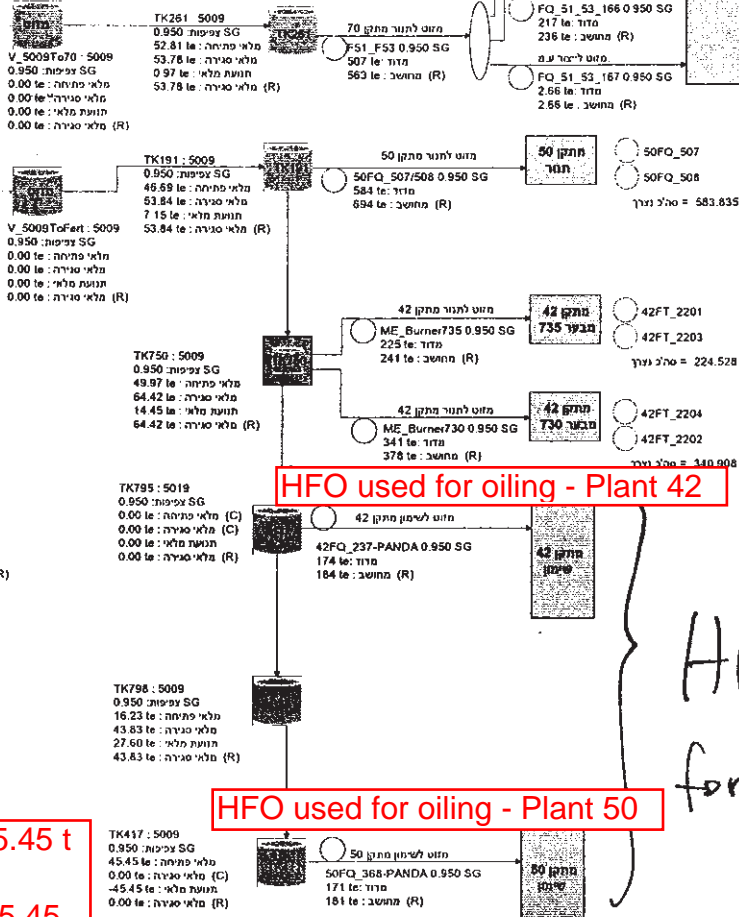

Opening Inventory - 45.45 t
 Closing Inventory - 0
 Total Consumption - 45.45

Measured Consumption - 171 t
 Calculated Consumption - 181 t

Mineral Oil Suppliers

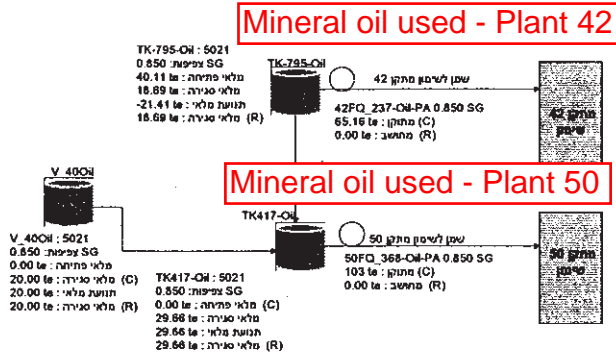

The following document describes the switching stages from HFO to Mineral oil in the oiling process - plants 42 & 50.

In Jan-2006 (Page 1), the plant was making its first use of the Mineral oil while still using large amounts of HFO for oiling.

In Feb-2006 (Page 2), the plant was using both HFO and Mineral oil in the oiling process.

In March 2006 (Page 3), the plant stopped using HFO for oiling and began operating using Mineral oil only.

20/1/2009 ECO

(שנתן אדמא)

02/2006

619 N 819

2

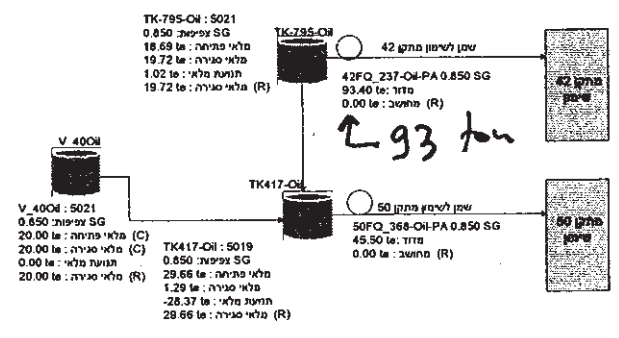
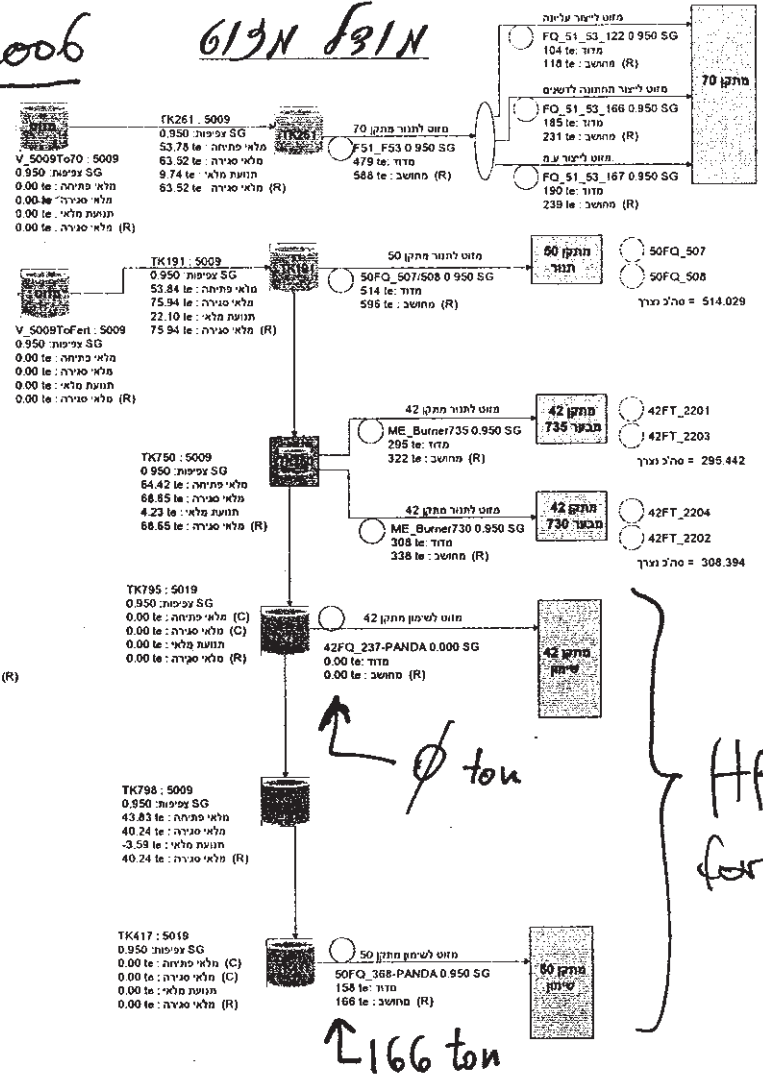

א.ב.ב.

03/2006

619N 891N

3

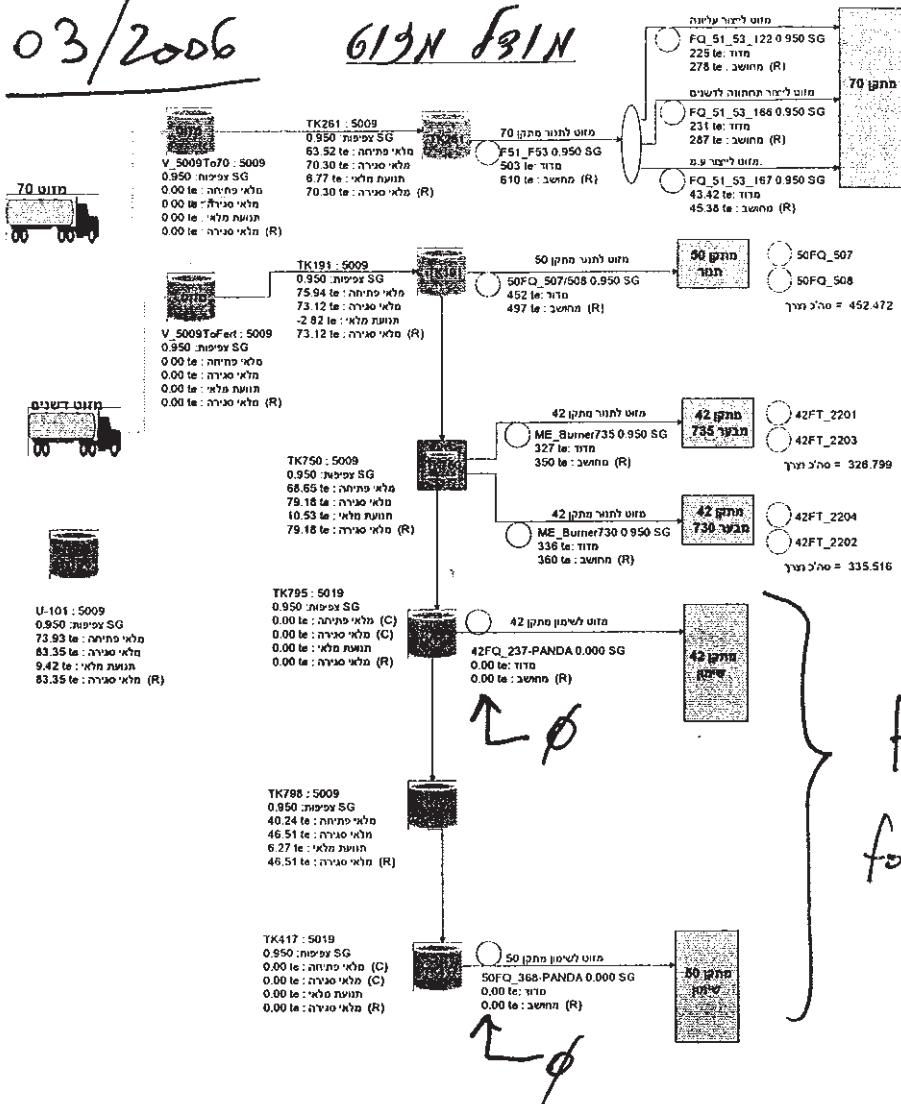

HFO for oiling

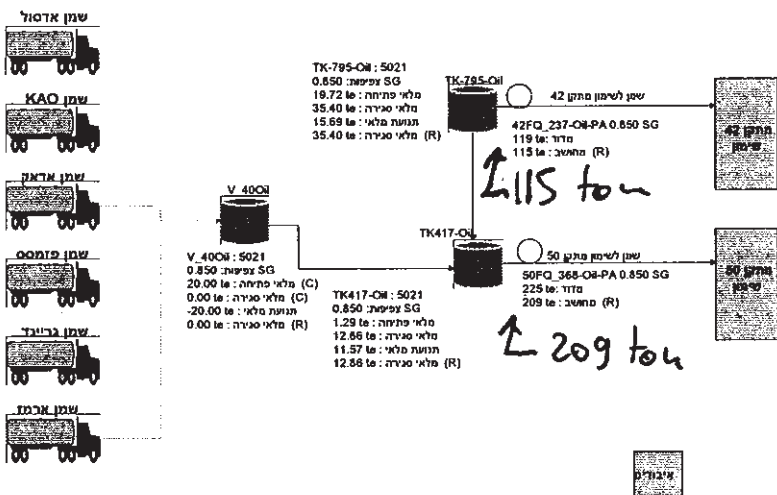

Mineral Oil

2115 ton

209 ton