



August 11, 2008

The Executive Board of the Clean Development Mechanism

Submitted through DNV

**Re: Request for review of the request for issuance for the CDM project activity  
'No.2 HFC23 Decomposition Project of Zhejiang Juhua Co., Ltd, P. R. China'  
(Ref. No. 0868)**

Dear Sirs:

Zhejiang Juhua Co., Ltd has been informed that the request for issuance for the second periodic verification for No.2 HFC23 Decomposition Project of Zhejiang Juhua Co., Ltd, P. R. China is under consideration for review because three requests for review have been received from three members of EB.

To address the reasons for the requests for review, project participant would like to make response and clarification through this letter.

**Reason**

Clarification is required on how the DOE verified the quantity of HFC23 stored eligible for destruction and HFC23 destruction for this monitoring period in accordance with the Annex 8 of EB39.

**PP response:**

1、 This monitoring period covers the project activity from November 01, 2007 to December 31, 2007, and on site verification is conducted by DNV on January 9-10, 2008, EB39 meeting is hold from May 14-16, 2008, so the relevant requirements of EB39 annex 8 were not described in monitoring report of this monitoring period.

2、 This project began to store HFC23 on April 6, 2007, stop to store HFC23 on July 11, 2007. Under the supervision of DNV, the line for HFC23 to the storage tank was disconnected on July 16, 2007. In the monitoring report for the first monitoring period, the quantity of HFC23 stored was identified as 135.81658 tonne. For this project, the method for calculating the quantity of HFC23 destruction credited in this monitoring period is essentially consistent with the calculation method represented in EB39 annex 8.

3、 For conservation reason and convenience to read and check, we calculated the quantity of HFC23 destruction credited in this monitoring period ( $Q_{\text{HFC23.cr.i.y}}$ ) according to the method represented in EB39 annex 8 and found that  $Q_{\text{HFC23.cr.i.y}}$  is 114.76612MT, which is equivalent to the data reported in Ver.02 of the Monitoring Report. Detail as below:

This project activity have been registered according to the approved methodology AM0001 Version 04, the following formulate is used to estimate the quantity of HFC23

destruction credited in this monitoring period.

$$Q_{HFC,cr,i,y} = MIN \left\{ \begin{array}{l} MIN \left( Q_{HCFC22,HIST} ; \sum_{n=1}^i Q_{HCFC22,n,y} \right) \times MIN \left( w ; \frac{\sum_{n=1}^i Q_{HFC23,g,n,y}}{\sum_{n=1}^i Q_{HCFC22,n,y}} \right) + Q_{HFC23,co,i,y} \\ \sum_{n=1}^i Q_{HFC23,d,n,y} \end{array} \right\} - \sum_{m=1}^{i-1} Q_{HFC23,cr,m,y}$$

Where:

$Q_{HFC23,cr,i,y}$  : Quantity of HFC23 destruction credited in the monitoring period  $i$  of year  $y$

$Q_{HCFC22,HIST}$  : The maximum annual HCFC-22 production that is eligible for crediting as determined and fixed in the registered CDM-PDD

$Q_{HCFC22,n,y}$  : Quantity of HCFC22 produced in the monitoring period  $n$  of year  $y$ , i.e.  $Q_{HCFC,y}$

$w$  : The waste generation rate (HFC23)/(HCFC22) for the originating production line as determined and fixed in the registered CDM-PDD

$Q_{HFC23,co,y}$  : Quantity of HFC23 stored by the end of year  $y-1$  and eligible for destruction in year  $y$

$Q_{HFC23,g,n,y}$  : Quantity of HFC23 generated in the monitoring period  $n$  of year  $y$

$Q_{HFC23,d,n,y}$  : Quantity of HFC23 destroyed in the monitoring period  $n$  of year  $y$

$Q_{HFC23,cr,m,y}$  : Quantity of HFC23 destruction credited in the monitoring period  $m$  of year  $y$

$i$  : Monitoring period for which issuance of CER is requested

$n$  : Monitoring periods from the start of the year up to the monitoring period  $i$

$m$  : Monitoring periods of year  $y$  that preceded the monitoring period  $i$

$$Q_{HFC,cr,i,y} = MIN \left\{ \begin{array}{l} MIN \left( Q_{HCFC22,HIST} ; \sum_{n=1}^i Q_{HCFC22,n,y} \right) \times MIN \left( w ; \frac{\sum_{n=1}^i Q_{HFC23,g,n,y}}{\sum_{n=1}^i Q_{HCFC22,n,y}} \right) + Q_{HFC23,co,i,y} \\ \sum_{n=1}^i Q_{HFC23,d,n,y} \end{array} \right\} - \sum_{m=1}^{i-1} Q_{HFC23,cr,m,y}$$

$$Q_{HFC,cr,i,y} = MIN \left\{ \frac{MIN (13708.9; 10811.46) \times MIN (3\%; 3.13\%) + 0}{298.78811} \right\} - 184.02199$$

$$Q_{HFC,cr,i,y} = MIN \left\{ \frac{10811.46 \times 3\% + 0}{298.78811} \right\} - 184.02199$$

$$Q_{HFC,cr,i,y} = MIN \left\{ \frac{324.3438}{298.78811} \right\} - 184.02199$$

$$Q_{HFC,cr,i,y} = 114.76612$$



Detail as below:

Period	Period of 1 <sup>st</sup> project year	QHCFC22 <sub>HIST</sub> <sup>ST</sup> MT (A)	$\sum_{n=1}^i Q_{HCFC22,n,y}$ MT (B)	w (C)	$\sum_{n=1}^i Q_{HFC23,g,n,y}$ MT (D)	$\frac{\sum_{n=1}^i Q_{HFC23,g,n,y}}{\sum_{n=1}^i Q_{HCFC22,n,y}}$ (E)=(D)/(B)	Q <sub>HFC,co,y</sub> MT (F)	$\sum_{m=1}^{i-1} Q_{HFC23,cr,m}$ (G)	$\sum_{n=1}^i Q_{HFC23,d,n,y}$ (H)
Apr 06,2007 to Oct 31,2007	1 <sup>st</sup>	13708.9	8634.24	3%	270.26857	3.13%	0	0	184.02199
Nov 01,2007 to Dec 31,2007	2 <sup>nd</sup>	13708.9	10811.46	3%	338.2871	3.13%	0	184.02199	298.78811

In this project, the start dating of the crediting period is April 6, 2007 and this monitoring period is the 2<sup>nd</sup> monitoring period of the 1<sup>st</sup> project year.

(A) QHCFC22<sub>HIST</sub>

This value is fixed in the registered CDM-PDD as 13708.9MT.

(B)  $\sum_{n=1}^i Q_{HCFC22,n,y}$

Period of 1 <sup>st</sup> project year	Q <sub>HCFC22,n,y</sub>	$\sum_{n=1}^i Q_{HCFC22,n,y}$
1 <sup>st</sup>	8634.24	8634.24
2 <sup>nd</sup>	2177.22 Refer to MR Appendix 5 Q_HCFC <sub>y</sub>	10811.46

(C) w

This value is fixed in the registered CDM-PDD as 3%.

(D)  $\sum_{n=1}^i Q_{HFC23,g,n,y}$

Period of 1 <sup>st</sup> project year	Q <sub>HFC23,g,n,y</sub>	$\sum_{n=1}^i Q_{HFC23,g,n,y}$
1 <sup>st</sup>	270.26857	270.26857
2 <sup>nd</sup>	68.01853	338.2871

(E)  $\frac{\sum_{n=1}^i Q_{HFC23,g,n,y}}{\sum_{n=1}^i Q_{HCFC22,n,y}}$



Period of 1st project year	$\frac{\sum_{n=1}^i Q_{\text{HFC23,g,n,y}}}{\sum_{n=1}^i Q_{\text{HFC22,n,y}}}$	$\frac{\sum_{n=1}^i Q_{\text{HFC23,g,n,y}}}{\sum_{n=1}^i Q_{\text{HFC22,n,y}}}$
1 <sup>st</sup>	270.26857/ 8634.24	3.13%
2 <sup>nd</sup>	338.2871/10811.46	3.13%

(F)  $Q_{\text{HFC23,co,y}}$

The quantity of HFC23 that has been stored by the end of last year and eligible for destruction in this project year ( $Q_{\text{HFC23,co,y}}$ ) is zero.

(G)  $\sum_{m=1}^{i-1} Q_{\text{HFC23,cr,m,y}}$

Period of 1st project year	$Q_{\text{HFC23,cr,m,y}}$	$\sum_{m=1}^{i-1} Q_{\text{HFC23,cr,m,y}}$
1 <sup>st</sup>	184.02199	0
2 <sup>nd</sup>		184.02199

(H)  $\sum_{n=1}^i Q_{\text{HFC23,d,n,y}}$

Period of 1st project year	$Q_{\text{HFC23,d,n,y}}$	$\sum_{n=1}^i Q_{\text{HFC23,d,n,y}}$
1 <sup>st</sup>	184.02199	184.02199
2 <sup>nd</sup>	114.76612	298.78811

The quantity of HFC23 destroyed ( $Q_{\text{HFC23,d,n,y}}$ ) is calculated as the product of the quantity of waste HFC23 supplied to the destruction process ( $q_{\text{HFC23}_y}$ ) measured in metric tonnes and the purity of the waste HFC23 ( $p_{\text{HFC23}_y}$ ) supplied to the destruction process which is determined and expressed as the fraction of HFC23 in the waste.

$$Q_{\text{HFC23,d,n,y}} = q_{\text{HFC23}_y} * p_{\text{HFC23}_y}$$

$$Q_{\text{HFC23,d,n,y}} = 115.37039 * 99.47623\%$$

$$Q_{\text{HFC23,d,n,y}} = 114.76612 \text{MT}$$

$q_{\text{HFC23}_y}$  : Refer to Appendix 1 of MR Ver.02

$p_{\text{HFC23}_y}$  : Refer to Appendix 2 of MR Ver.02

It can be seen that the quantity of HFC23 destruction credited in this monitoring period calculated according to the method represented in EB39 annex 8 is 114.76612 MT, which is equivalent to the amount reported in Ver.02 of the monitoring report.

**Reason**

The monitoring report (page 4) stated that "HFC23 waste gas generated in ...is sent to these three HFC23 buffer tanks, after measured by HFC23 flow meters, and then those HFC23 enter into the incinerator to be decomposed." Further clarification is required on how the quantity of HFC23 supplied to the destruction process was measured.

**PP response:**

In monitoring report (page 4) stated that "In this project, there are three HFC23 buffer tanks. HFC23 waste gas generated in No.703 and No.4-703 HCFC22 production lines is sent to these three HFC23 buffer tanks, after measured by HFC23 flow meters, and then those HFC23 enter into the incinerator to be decomposed." The above description is not very clear, the correct one should be "In this project, there are three HFC23 buffer tanks. The HFC23 waste gas generated in No.703 and No.4-703 HCFC22 production lines is sent to these three HFC23 buffer tanks first, then HFC23 waste gas will be measured by HFC23 flow meters and finally send to the destruction process."

The following is the more detailed description:

In this project, there are three buffer tanks (gas phase tank) .The purpose of buffer tanks is to buffer against the HFC23 generated from No.703 and No.4-703 HCFC22 product lines. When the incinerator shutting down, the HFC23 generated from these HCFC22 product lines would be stored temporarily in these buffer tanks, and be destroyed after incinerator is put into operation again. In normal circumstance, those buffer tanks are not used to store HFC23 generated from No.703 and No.4-703 HCFC22 production lines, their function is only to buffer against the HFC23. These three buffer tanks (gas phase tank) were installed before HFC23 flow meters (i.e. flow meters measuring the quantity of HFC23 supplied to the destruction process).

The location relationship between those buffer tanks and the flow meters used to measure the quantity of HFC23 supplied to the destruction process is shown below:

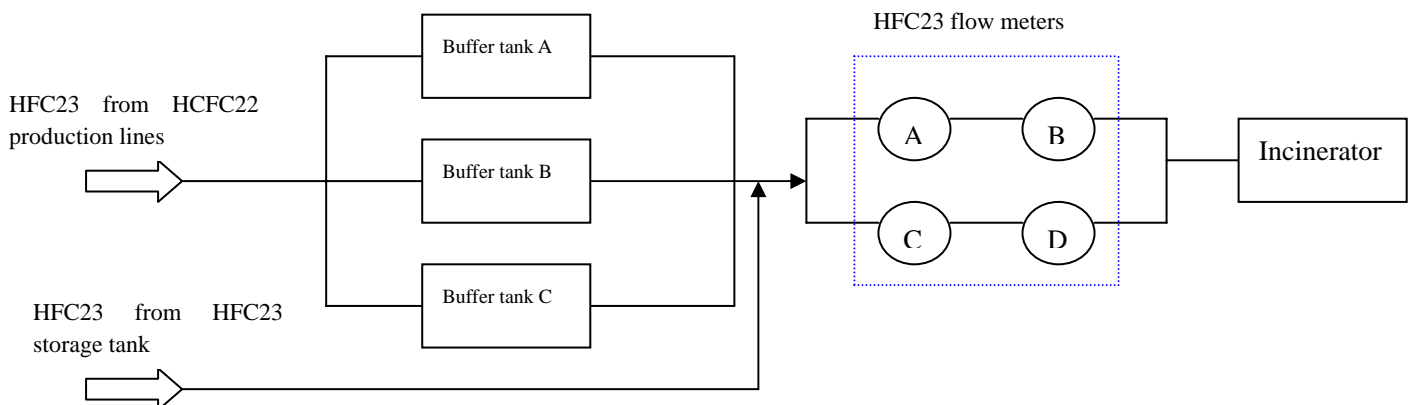



**Reason**

The monitoring report stated that incinerator was shut down in 4-5 and 23-26 December 2007 while it provides analysis data of the effluent gas on 3 and 23 December 2007. Clarification is required.

**PP response:**

The quantity of HFC23 in gaseous effluent is monitored strictly in accordance with the requirements of approved methodology AM0001, i.e. when the thermal oxidizer stops, analysis of the effluent gas is done to check leaked HFC23 by sampling.

During this monitoring period, the incinerator was shut down in December 4-5 and 23-26 2007, analysis of the effluent gas is done on December 4, 2007 and December 23, 2007 respectively. The date *December 3, 2007* reported on page 26 of the monitoring report Ver.02, is a type mistake, it should be **December 4, 2007**, and the analysis report is available if required.

We hope that this letter address and clarify the relevant questions. If further information is required, Zhang Xueliang will be the contact person for the review process and is available to address questions from EB during the consideration of the review in case the Executive Board wishes.

Zhang Xueliang  
Zhejiang Juhua Co., Ltd.  
Address: Quzhou, Zhejiang Province, P.R.China  
E-mail: [fhzxl@juhua.com.cn](mailto:fhzxl@juhua.com.cn)  
Tel: +86-570-3614382  
Fax: +86-570-3098687  
P.C. 324004

