

Draft baseline and monitoring methodology AM00XX**“Integrated Solar Combined Cycle (ISCC) projects”****I. SOURCE, DEFINITIONS AND APPLICABILITY****Sources**

This baseline and monitoring methodology is based on elements from the following proposed new methodology:

- NM00345 “Methodology for conversion of a Combined Cycle Power Plant to an Integrated Solar Combined Cycle (ISCC)” prepared by Fichtner Carbon Management GmbH.

This methodology also refers to the latest approved versions of the following tools:

- “Tool to calculate project or leakage CO₂ emissions from fossil fuel combustion”;
- “Combined tool to identify the baseline scenario and demonstrate additionality”;
- “Tool to calculate the emission factor for an electricity system”;
- “Tool to assess the validity of the original/current baseline and to update the baseline at the renewal of a crediting period”.

For more information regarding the proposed new methodologies and the tools as well as their consideration by the Executive Board please refer to <<http://cdm.unfccc.int/goto/MPappmeth>>.

Selected approach from paragraph 48 of the CDM modalities and procedures

“Existing actual or historical emissions, as applicable;” and “Emissions from a technology that represents an economically attractive course of action, taking into account barriers to investment.”

Definitions

For the purpose of this methodology, the following definitions apply:

Combined Cycle Power Plant (CC). A combined-cycle power plant is a power plant that combines the Rankine -steam turbine- and Brayton -gas turbine- thermodynamic cycles, by using Heat Recovery Steam Generator (HRSG) to capture the energy in the gas turbine exhaust gases for steam production to supply a steam turbine.

Electric Solar Capacity. The gross electricity output (in MW) of the steam turbine that can be attributed to Solar Heat at its design conditions when the solar steam generator operates at maximum design capacity

Electric Steam Turbine Capacity. The gross electricity output (in MW) of the steam turbine at design conditions.

Heat Recovery Steam Generator (HRSG). An installation that uses the heat of a gas turbine’s exhaust gas, as well as a Supplementary Firing (if applicable), to heat and evaporate water and (if applicable) superheat steam.

Heat Transfer Fluid (HTF). A fluid which is used as a medium to collect the heat in the solar field and to transfer it to the solar steam generator.

Integrated Solar Combined Cycle (ISCC). Consists of a combined cycle power plant and a Solar Field connected to the combined cycle. The thermal energy of both the combined cycle power plant and the Solar Field are converted into electricity in the same steam turbine.

Solar Field. Consists of all equipment that is necessary to transform solar irradiation into thermal energy in the form of steam. Thus, for the purpose of this methodology the SSG forms part of the solar field. All equipment that is necessary to operate the solar field such as pumps, anti-freeze protection heaters, motors, electrical connections, etc. shall be considered as part of the Solar Field.

Solar Steam Generator (SSG). An installation generating steam (either saturated or superheated) from feed water returning from the condenser. Only thermal energy from solar irradiation is used in an SSG.

Applicability

This methodology applies to project activities that implements Integrated Solar Combined Cycle (ISCC) project.

The proposed project activity can be characterised as one of the following three options:

- D1: The conversion of an existing Combined Cycle Power Plant into an ISCC; or
- D2: The conversion of an existing single cycle gas turbine power plant into an ISCC, where the project activity comprises exclusively the Solar Field and Supplementary Firing; or
- D3: The construction of a new ISCC, where the project activity comprises exclusively the Solar Field and Supplementary Firing.

The methodology is applicable under the following conditions:

- The Electric Solar Capacity does not account for more than 15% of the Electric Steam Turbine Capacity of the ISCC. This limitation is necessary in order to avoid considerable negative effects on the Rankine Cycle efficiency during times of no or low solar irradiation;¹
- A water steam chart or appropriate software according to international standard (for example IAPWS-IF 97²) is used to calculate the properties of water and steam (e.g. enthalpies, entropies) from the measured pressure and temperature.

In addition, the applicability conditions included in the tools referred to above apply.

Finally, this methodology is only applicable if the most plausible baseline scenario, as identified per the section “Identification of the baseline scenario and demonstration of additionality” hereunder, is:

- P1: Continuation of the operation of an existing Combined Cycle Power Plant or an existing single cycle gas turbine power plant at the project site with grid connection and without any use of solar energy; or
- P2: Conversion of an existing single cycle gas turbine power plant to a Combined Cycle Power Plant at the project site with grid connection and without any use of solar energy; or

¹ The steam turbine of the ISCC has to be designed for maximum solar heat, i.e. it will be larger than in a CC with the same gas turbine. Hence, at operating points with no solar irradiation the steam turbine will operate in part load conditions whereas in the CC it would operate at full load. Usually, from 100% to 85% of the nominal load the efficiency of the steam turbine is approximately constant. Hence, by limiting the Electric Solar Capacity to 15% the negative effects of increased part load become negligible.

² Revised release on the IAPWS Industrial Formulation 1997 for the Thermodynamic Properties of Water and Steam (IAPWS Industrial Formulation 1997) <available at: <http://www.iapws.org/relguide/IF97-Rev.pdf>>.

P3: Construction and operation of a Combined Cycle Power Plant as a Greenfield project at the project site with grid connection and without any use of solar energy.

II. BASELINE METHODOLOGY PROCEDURE

Project boundary

The **spatial extent** of the project boundary encompasses the project facility (ISCC) including solar field, combined cycle power plant and the supplementary firing and all power plants connected physically to the electricity grid as defined in “Tool to calculate emission factor for an electricity system”

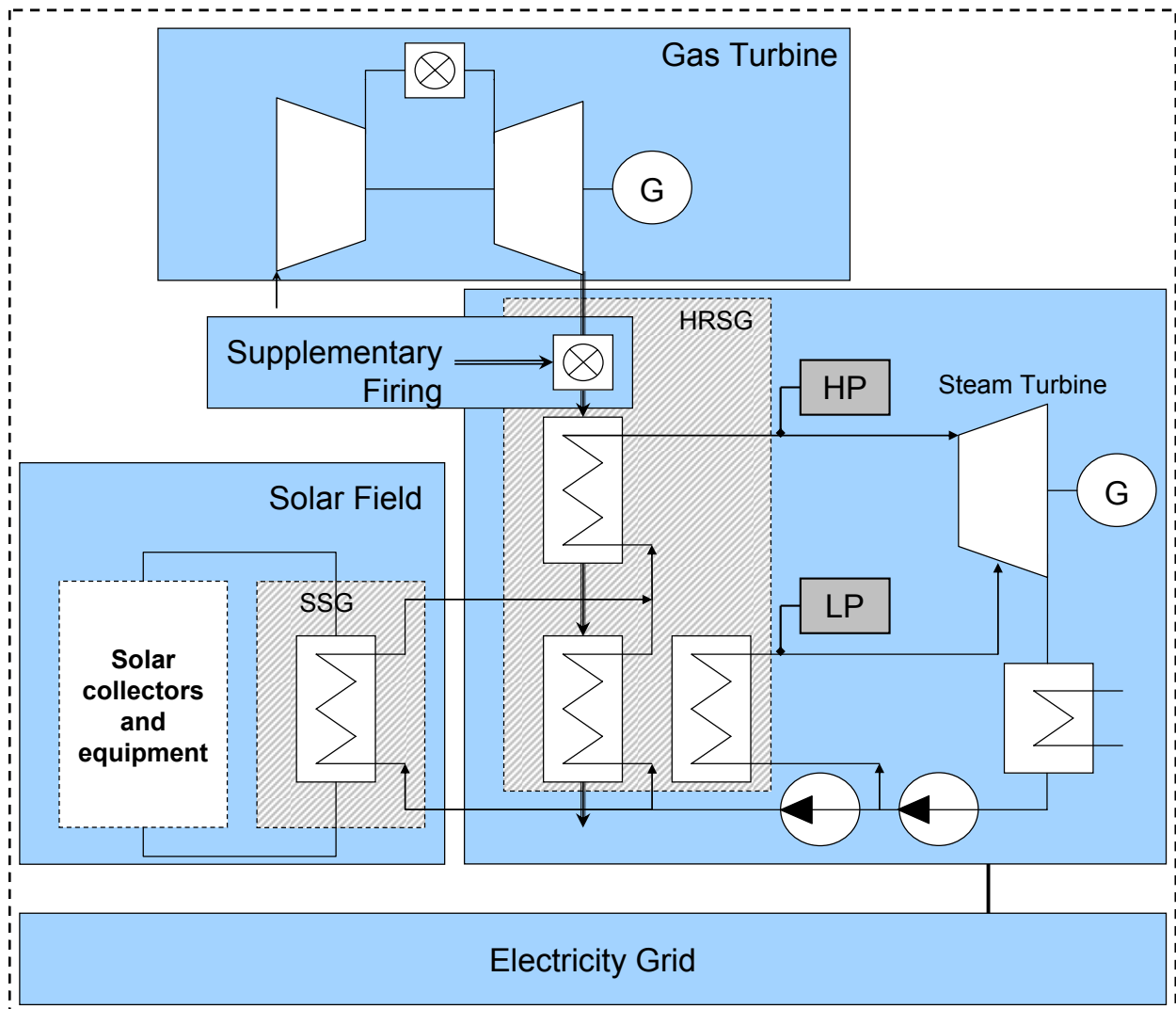

Figure 1: Simplified layout of an ISCC with illustration of the above definitions (project boundary illustrated as dotted line)

The greenhouse gases included in or excluded from the project boundary are shown in Table 1.

Table 1: Emissions sources included in or excluded from the project boundary

Source		Gas	Included?	Justification / Explanation
Baseline	Grid electricity generation	CO ₂	Yes	Main emission source
		CH ₄	No	Excluded for simplification. This is conservative
		N ₂ O	No	Excluded for simplification. This is conservative
	On-site fuel consumption to operate the Supplementary Firing	CO ₂	Yes	An important emission source
		CH ₄	No	Excluded for simplification. This emission source is assumed to be very small
		N ₂ O	No	Excluded for simplification. This emission source is assumed to be very small
Project activity	On-site fuel consumption to operate the Supplementary Firing	CO ₂	Yes	An important emission source
		CH ₄	No	Excluded for simplification. This emission source is assumed to be very small
		N ₂ O	No	Excluded for simplification. This emission source is assumed to be very small
	On-site fossil fuel consumption attributable to the Solar Heat production process	CO ₂	Yes	Minor emission source
		CH ₄	No	Excluded for simplification. This emission source is assumed to be very small
		N ₂ O	No	Excluded for simplification. This emission source is assumed to be very small

Selection of the baseline scenario and demonstration of additionality

The selection of the baseline scenario and the demonstration of additionality should be conducted using the latest version of the “Combined tool to identify the baseline scenario and demonstrate additionality”. The following additional guidance should be used when applying the tool.

When applying “Sub-step 1a” of the tool, alternative scenarios for power generation should include all realistic and credible alternatives to the project activity that are consistent with current laws and regulations of the host country.

The following likely scenarios of power generation shall be assessed, *inter alia*:

- P1: Continuation of the operation of an existing Combined Cycle Power Plant or existing single cycle gas turbine power plant at the project site with grid connection and without any use of solar energy and the additional electricity that is generated from the solar energy in the project activity would be generated in the grid or by the supplementary firing. In case the project activity is the construction of a new ISCC (D3), this alternative need not to be considered;
- P2: Conversion of an existing single cycle gas turbine power plant to a Combined Cycle Power Plant at the project site with grid connection and without any use of solar energy and the additional electricity that is generated from the solar energy in the project activity would be generated in the grid or by the supplementary firing. In case the project activity is the conversion of an existing Combined Cycle Power Plant to an ISCC (D1) or the construction of a new ISCC (D3), this alternative need not to be considered;

- P3: Construction and operation of a Combined Cycle Power Plant as a greenfield project at the project site with grid connection and without any use of solar energy. In case the project activity is the conversion of an existing Combined Cycle Power Plant to an ISCC (D1) or conversion of an existing single cycle gas turbine power plant to an ISCC (D2), this alternative need not to be considered;
- P4: The construction of one or several other power plant(s) using fossil fuels;
- P5: The construction of one or several other power plant(s) using renewable power generation technologies;
- P6: Project Activity not undertaken as a CDM project.

For the additionality demonstration “Step 3: Investment analysis” of the tool shall be used, following the guidance provided for scenario S2 in the tool; i.e. no investment is undertaken by the project participants but third party(ies) undertake(s) investments or actions which provide comparable outputs or services to users of the project activity. For the calculation of the financial indicators, all expenses and revenues related only to the solar component shall be included in the analysis.

Baseline emissions

Baseline emissions will be calculated according to the following formula.

$$BE_y = EG_{project,y} \times \min\{EF_{sup,y}; EF_{grid,y}\} \quad (1)$$

Where:

BE_y	=	Baseline emissions in year y (tCO ₂ e)
$EG_{project,y}$	=	Project electricity generation in year y (MWh)
$EF_{grid,y}$	=	Grid emission factor (tCO ₂ /MWh)
$EF_{sup,y}$	=	Emission factor for electricity generation using supplementary firing in year y (tCO ₂ /MWh)

Baseline emissions will be calculated ex-post based on the actual generation by the project activity. For the ex-ante estimation of the emission reduction, data from the feasibility study report or at least as substantiated as those from a pre-feasibility study shall be used.

Determination of project electricity generation ($EG_{project,y}$)

The term project electricity generation only refers to the amount electricity attributed to the installation and operation of the Solar Field and the Supplementary Firing. Hence, the emissions from the gas turbine as well as its electricity generation are not part of the project electricity generation. The electricity generation attributable to the waste heat from the gas turbine’s exhaust is not included in the project electricity generation either.

$$EG_{project,y} = EG_{solar,y} + EG_{sup,y} \quad (2)$$

Where:

$EG_{project,y}$	=	Project electricity generation in year y (MWh)
$EG_{solar,y}$	=	Electricity generation from the solar heat in year y (MWh)
$EG_{sup,y}$	=	Electricity generation from the supplementary firing in year y (MWh)

Determination of electricity generation from Solar Heat

For the measurement points to determine the parameters in the equations below, please refer to the diagram contained in the section “III. Monitoring Methodology” hereinafter.

$$EG_{solar,y} = EG_{ST,y} \times ES_{SSG,y} - EC_{SF,y} \quad (3)$$

Where:

$EG_{solar,y}$	= Electricity generation from the solar heat in year y (MWh)
$EG_{ST,y}$	= Net electricity generation from the steam turbine in year y (MWh)
$ES_{SSG,y}$	= Exergetic share of the solar steam in year y (Fraction)
$EC_{SF,y}$	= Electricity consumption of the solar field in year y (MWh)

Electricity consumption by the Solar Field shall comprise all power loads attributable to the operation of the solar field, including as necessary:

- Heat transfer fluid (HTF) pumps;
- Freeze-protection pumps;
- Feedwater pump for the Solar Field (if a separate pump is installed);
- Other equipment related to the solar component of the project (e.g. motors for adjusting mirrors).

Determination of net electricity generation from the steam turbine in year y ($EG_{ST,y}$)

Net electricity generation from the steam turbine in year y ($EG_{ST,y}$) shall be calculated as follows:

$$EG_{ST,y} = EG_{ISCC,y} - EG_{GT,gross,y} \quad (4)$$

Where:

$EG_{ST,y}$	= Net electricity generation from the steam turbine in year y (MWh)
$EG_{ISCC,y}$	= Net electricity generation from the ISCC measured at the substation deducted by all electricity purchased from the grid in year y (MWh)
$EG_{GT,gross,y}$	= Gross electricity generation from gas turbine measured at the generator terminal in year y (MWh)

The exergetic³ share of the Solar Heat in year y shall be calculated as follows:

$$ES_{SSG,y} = \frac{EX_{SSG,y}}{EX_{HP,y} + EX_{LP,y}} \quad (5)$$

³ By using exergy for the calculations the contribution of each heat source to the power generation can be determined correctly. The use of exergy for calculations instead of energy becomes necessary whenever heat is added to a process from various sources at different temperatures. In the case of an ISCC the heat in the solar steam generator and the heat in the HRSG are added to the Rankine Cycle at different temperatures in most processes. Consequently, they are converted to electricity with different efficiencies as per the second law of thermodynamics. Hence, correct results can be obtained using the exergetic.

Where:

- $ES_{SSG,y}$ = Exergetic share of the solar steam in year y (Fraction)
 $EX_{SSG,y}$ = Exergy of the solar steam in year y (MWh)
 $EX_{HP,y}$ = Exergy of the high pressure steam in year y (MWh)
 $EX_{LP,y}$ = Exergy of the low pressure steam in year y (MWh) (in case of single stage steam turbine where low pressure steam is not fed into the steam turbine, $EX_{LP,y}$ is zero)

The exergy of the steam from the solar steam generator can be calculated as follows:

$$EX_{SSG,y} = 2.78 \times 10^{-7} \times \sum_{x=1}^{8760} m_{SSG,x} \times [h_{SSG,x} - h_{0,x} - (T_{0,x} \times (s_{SSG,x} - s_{0,x}))] \quad (6)$$

Where:

- $EX_{SSG,y}$ = Exergy of the solar steam in year y (MWh)
 2.78×10^{-7} = Conversion factor from kJ to MWh
 $m_{SSG,x}$ = Mass flow of the steam leaving the solar steam generator during hour x (kg)
 $h_{SSG,x}$ = Average specific enthalpy of the steam leaving the solar steam generator during hour x (kJ/kg)
 $h_{0,x}$ = Average specific enthalpy of the water at the condenser outlet during hour x (kJ/kg)
 $T_{0,x}$ = Average temperature of the water at the condenser outlet during hour x (K)
 $s_{SSG,x}$ = Average specific entropy of the steam leaving the solar steam generator during hour x (kJ/kgK)
 $s_{0,x}$ = Average specific entropy of the water at the condenser outlet during hour x (kJ/kgK)
 x = Measurement interval (1 hour). The value of x can be up to 8760 in a year, if the plant operates throughout. In case the plant has been shut down for some period in year y , in that year, use the number of measurement for x for the operational hour only

The exergy of the high pressure steam can be calculated as follows:

$$EX_{HP,y} = 2.78 \times 10^{-7} \times \sum_{x=1}^{8760} m_{HP,x} \times [h_{HP,x} - h_{0,x} - (T_{0,x} \times (s_{HP,x} - s_{0,x}))] \quad (7)$$

Where:

- $EX_{HP,y}$ = Exergy of the high pressure steam in year y (MWh)
 2.78×10^{-7} = Conversion factor from kJ to MWh
 $m_{HP,x}$ = Mass flow of the high pressure steam entering the steam turbine during hour x (kg)
 $h_{HP,x}$ = Average specific enthalpy of the high pressure steam entering the steam turbine during hour x (kJ/kg)
 $h_{0,x}$ = Average specific enthalpy of the water at the condenser outlet during hour x (kJ/kg)
 $T_{0,x}$ = Average temperature of the water at the condenser outlet during hour x (K)
 $s_{HP,x}$ = Average specific entropy of the high pressure steam entering the steam turbine during hour x (kJ/kgK)
 $s_{0,x}$ = Average specific entropy of the water at the condenser outlet during hour x (kJ/kgK)
 x = Measurement interval (1 hour). The value of x can be up to 8760 in a year, if the plant operates throughout. In case the plant has been shut down for some period in year y , in that year, use the number of measurement for x for the operational hour only

The exergy of the low pressure steam can be calculated as follows (in case of single stage steam turbine where low pressure steam is not fed into the steam turbine, $EX_{LP,y}$ is zero.):

$$EX_{LP,y} = 2.78 \times 10^{-7} \times \sum_{x=1}^{8760} m_{LP,x} \times [h_{LP,x} - h_{0,x} - (T_{0,x} \times (s_{LP,x} - s_{0,x}))] \quad (8)$$

Where:

$EX_{LP,y}$	= Exergy of the low pressure steam in year y (MWh)
2.78×10^{-7}	= Conversion factor from kJ to MWh
$m_{LP,x}$	= Mass flow of the low pressure steam entering the steam turbine during hour x (kg)
$h_{LP,x}$	= Average specific enthalpy of the low pressure steam entering the steam turbine during hour x (kJ/kg)
$h_{0,x}$	= Average specific enthalpy of the water at the condenser outlet during hour x (kJ/kg)
$T_{0,x}$	= Average temperature of the water at the condenser outlet during hour x (K)
$s_{LP,x}$	= Average specific entropy of the low pressure steam during hour x (kJ/kgK)
$s_{0,x}$	= Average specific entropy of the water at the condenser outlet during hour x (kJ/kgK)
x	= Measurement interval (1 hour). The value of x can be up to 8760 in a year, if the plant operates throughout. In case the plant has been shut down for some period in year y , in that year, use the number of measurement for x for the operational hour only

Determination of electricity generation from Supplementary Firing

The electricity generation from Supplementary Firing shall be calculated as follows:

$$EG_{sup,y} = EG_{ST,y} \times ES_{sup,y} \quad (9)$$

Where:

$EG_{sup,y}$	= Electricity generation from the supplementary firing in year y (MWh)
$ES_{sup,y}$	= Energetic share of the supplementary firing in year y (Fraction)
$EG_{ST,y}$	= Net electricity generation from the steam turbine in year y (MWh)

The energetic share of the Supplementary Firing shall be determined as follows:

$$ES_{sup,y} = \frac{E_{sup,y}}{E_{HP,y} + E_{LP,y}} \quad (10)$$

Where:

$ES_{sup,y}$	= Energetic share of the supplementary firing in year y (Fraction)
$E_{sup,y}$	= Energy of the supplementary firing in year y (MWh)
$E_{HP,y}$	= Energy of the high pressure steam in year y (MWh)
$E_{LP,y}$	= Energy of the low pressure steam in year y (MWh) (in case of single stage steam turbine where low pressure steam is not fed into the steam turbine, $E_{LP,y}$ is zero)

The energy of the Supplementary Firing shall be determined as follows:

$$E_{sup,y} = \frac{1}{0.0036} \sum_i m_{i,y} \times NCV_{i,y} \times \eta_{E,sup,y} \quad (11)$$

Where:

$E_{sup,y}$	= Energy of the supplementary firing in year y (MWh)
$m_{i,y}$	= Mass/volume of supplementary fuel i combusted in year y (ton or m^3)
$NCV_{i,y}$	= Net calorific value of the fuel i in year y (TJ/ton or m^3)
$\eta_{E,sup,y}$	= Efficiency of HRSG which converts energy in the supplementary fuel to steam (to calculate energy from the supplementary firing) (-)
$1/0.0036$	= Conversion factor from TJ to MWh

The energy of the high pressure steam shall be determined as follows:

$$E_{HP,y} = 2.78 \times 10^{-7} \times \sum_{x=1}^{8760} m_{HP,x} \times (h_{HP,x} - h_{0,x}) \quad (12)$$

Where:

$E_{HP,y}$	= Energy of the high pressure steam in year y (MWh)
2.78×10^{-7}	= Conversion factor from kJ to MWh
$m_{HP,x}$	= Mass flow of the high pressure steam entering the steam turbine during hour x (kg)
$h_{HP,x}$	= Average specific enthalpy of the high pressure steam entering the steam turbine during hour x (kJ/kg)
$h_{0,x}$	= Average specific enthalpy of the water at the condenser outlet during hour x (kJ/kg)
x	= Measurement interval (1 hour). The value of x can be up to 8760 in a year, if the plant operates throughout. In case the plant has been shut down for some period in year y , in that year, use the number of measurement for x for the operational hour only

The energy of the low pressure steam shall be determined as follows (in case of single stage steam turbine where low pressure steam is not fed into the steam turbine, $E_{LP,y}$ is zero.):

$$E_{LP,y} = 2.78 \times 10^{-7} \times \sum_{x=1}^{8760} m_{LP,x} \times (h_{LP,x} - h_{0,x}) \quad (13)$$

Where:

$E_{LP,y}$	= Energy of the low pressure steam in year y (MWh)
2.78×10^{-7}	= Conversion factor from kJ to MWh
$m_{LP,x}$	= Mass flow of the low pressure steam entering the steam turbine during hour x (kg)
$h_{LP,x}$	= Average specific enthalpy of the low pressure steam entering the steam turbine during hour x (kJ/kg)
$h_{0,x}$	= Average specific enthalpy of the water at the condenser outlet during hour x (kJ/kg)
x	= Measurement interval (1 hour). The value of x can be up to 8760 in a year, if the plant operates throughout. In case the plant has been shut down for some period in year y , in that year, use the number of measurement for x for the operational hour only

Determination of the baseline emission factor $EF_{grid,y}$ and $EF_{sup,y}$

The project electricity will partly replace electricity from the grid and partly electricity generated by the HRSG's supplementary firing. Thus, it is conservative to define the baseline CO₂ emission factor as the minimum value of the following two emission factors:

- Emission factor for electricity generation using Supplementary Firings of the HRSG (in tCO₂/MWh);
- Emission factor for the electricity grid (in tCO₂/MWh).

Determination of Emission factor for electricity generation using Supplementary Firing ($EF_{sup,y}$)

$$EF_{sup,y} = 0.0036 \times \frac{\sum_i EF_{i,y} \times m_{i,y}}{\sum_i m_{i,y}} \times \frac{1}{EFF_{Rankine} \times \eta_{EF,sup,y}} \quad (14)$$

Where:

- $EF_{sup,y}$ = Emission factor for electricity generation using supplementary firing in year y (tCO₂/MWh)
 0.0036 = Conversion factor from MWh to TJ
 $EF_{i,y}$ = Emission factor of the supplementary fuel i combusted in year y (tCO₂/TJ)
 $m_{i,y}$ = Mass/volume of supplementary fuel i combusted in year y (ton or m³)
 $\eta_{EF,sup,y}$ = Efficiency of HRSG which converts energy in the supplementary fuel to steam (for emission factor of electricity generation from the supplementary firing) (-)
 $EFF_{Rankine}$ = Annual efficiency of the Rankine Cycle (-)

$$EFF_{Rankine} = \frac{EG_{ST,y}}{E_{HP,y} + E_{LP,y}} \quad (15)$$

Where:

- $EFF_{Rankine}$ = Annual efficiency of the Rankine Cycle (-)
 $EG_{ST,y}$ = Net electricity generation from the steam turbine in year y (MWh)
 $E_{HP,y}$ = Energy of the high pressure steam in year y (MWh)
 $E_{LP,y}$ = Energy of the low pressure steam in year y (MWh) (In case of single stage steam turbine where low pressure steam is not fed into the steam turbine, $E_{LP,y}$ is zero)

Determination of grid emission factor ($EF_{grid,y}$)

The grid emission factor shall be calculated using the latest version of the “Tool to calculate the emission factor for an electricity system”.

Project emissions

Project emissions are calculated as follows:

$$PE_y = PE_{FC,y} \quad (16)$$

Where:

- PE_y = Project emissions in year y (tCO₂e)
 $PE_{FC,y}$ = Project emissions from fossil fuel combustion in year y (tCO₂e)

Determination of project emissions from fossil fuel combustion

Project emissions from fossil fuel combustion in year y ($PE_{FC,y}$) are calculated using the latest approved version of the “Tool to calculate project or leakage CO₂ emissions from fossil fuel combustion”, where parameter $FC_{i,j,y}$ of the tool correspond to the quantity of fossil fuel consumption in supplementary firing ($m_{i,y}$) and any other fuel combusted in equipments that forms part of the solar field. All emission sources should be documented transparently in the CDM-PDD.

Leakage

No leakage is considered.

Emission reductions

Emission reductions are calculated as follows:

$$ER_y = BE_y - PE_y \quad (17)$$

Where:

ER_y = Emission reductions in year y (tCO₂e)
 BE_y = Baseline emissions in year y (tCO₂e)
 PE_y = Project emissions in year y (tCO₂e)

Changes required for methodology implementation in 2nd and 3rd crediting periods

Refer to the “Tool to assess the validity of the original/current baseline and to update the baseline at the renewal of a crediting period”.

Data and parameters not monitored

The provisions on data and parameters not monitored in the tools referred to in this methodology apply.

III. MONITORING METHODOLOGY

All data collected as part of monitoring should be archived electronically and be kept at least for 2 years after the end of the last crediting period. 100% of the data should be monitored if not indicated otherwise in the tables below. All measurements should be conducted with calibrated measurement equipment according to relevant industry standards.

In addition, the monitoring provisions in the tools referred to in this methodology apply.

The measurement points shall be defined as follows:

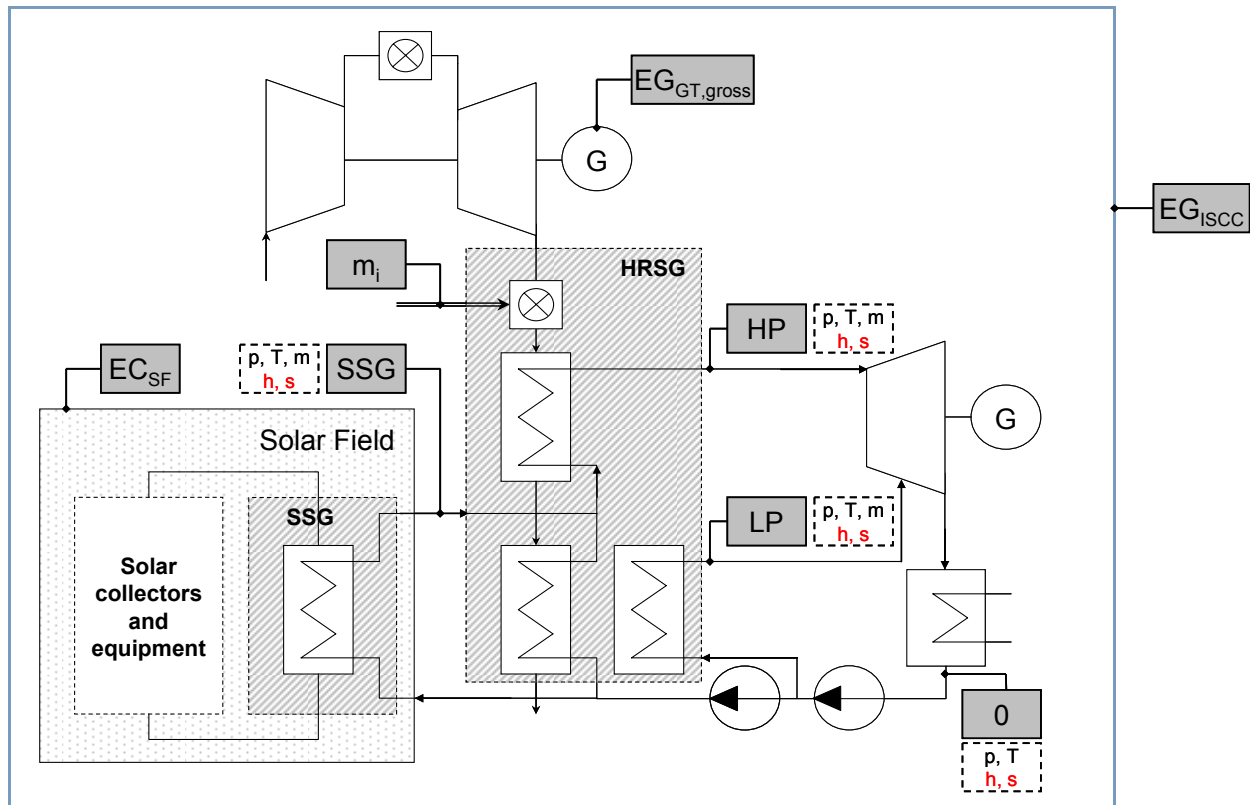

Figure 2: Simplified layout of an ISCC with definitions of the measurement points; measured parameters in the Rankine cycle are indicated in black, process parameters that are directly calculated from these measurements and monitored are shown in red

Necessary measurements are:

- At measurement point SSG:
 - Average temperature of the steam leaving the solar steam generator during hour x ($T_{SSG,x}$);
 - Average pressure of the steam leaving the solar steam generator during hour x ($p_{SSG,x}$);
 - Mass flow of the steam leaving the solar steam generator during hour x ($m_{SSG,x}$).
- At measurement point HP:
 - Average temperature of the high pressure steam entering the steam turbine during hour x ($T_{HP,x}$);
 - Average pressure of the high pressure steam entering the steam turbine during hour x ($p_{HP,x}$);
 - Mass flow of the high pressure steam entering the steam turbine during hour x ($m_{HP,x}$).
- At measurement point LP:
 - Average temperature of the low pressure steam entering the steam turbine during hour x ($T_{LP,x}$);
 - Average pressure of the low pressure steam entering the steam turbine during hour x ($p_{LP,x}$);
 - Mass flow of low pressure steam entering the steam turbine during hour x ($m_{LP,x}$).

- At measurement point 0:
 - Average temperature of the water at the condenser outlet during hour x ($T_{0,x}$);
 - Average pressure of the water at the condenser outlet during hour x ($p_{0,x}$).
- At measurement point $EG_{GT, gross}$:
 - Gross electricity generation from gas turbine measured at the generator terminal in year y ($EG_{GT, gross, y}$).
- At measurement point EG_{ISCC} :
 - Net electricity generation from the ISCC measured at the substation deducted by all electricity purchased from the grid in year y ($EG_{ISCC, y}$).
- At measurement point EC_{SF} :
 - Electricity consumption of the solar field in year y ($EC_{SF, y}$).
- At measurement point m_i :
 - Mass/volume of supplementary fuel i combusted in year y ($m_{i, y}$);
 - Net calorific value of the fuel i in year y ($NCV_{i, y}$);
 - Emission factor of the supplementary fuel i combusted in year y ($EF_{i, y}$).

From the parameters above, values of the following parameters can be derived (e.g. from a water-steam chart or table):

- At measurement point SSG:
 - Average specific enthalpy of the steam leaving the solar steam generator during hour x ($h_{SSG, x}$);
 - Average specific entropy of the steam leaving the solar steam generator during hour x ($s_{SSG, x}$).
- At measurement point HP:
 - Average specific enthalpy of the high pressure steam entering the steam turbine during hour x ($h_{HP, x}$);
 - Average specific entropy of the high pressure steam entering the steam turbine during hour x ($s_{HP, x}$).
- At measurement point LP:
 - Average specific enthalpy of the low pressure steam entering the steam turbine during hour x ($h_{LP, x}$);
 - Average specific entropy of the low pressure steam during hour x ($s_{LP, x}$).
- At measurement point 0:
 - Average specific enthalpy of the water at the condenser outlet during hour x ($h_{0, x}$);
 - Average specific entropy of the water at the condenser outlet during hour x ($s_{0, x}$).

Data and parameters monitored

The following parameters shall be monitored:

Data / Parameter:	$T_{HP,x}$
Data unit:	°C
Description:	Average temperature of the high pressure steam during hour x
Source of data:	Plant record Read out of measurement data from the plant control system and transfer to a data acquisition system with evaluation database and data storage for recording and reporting of monitored parameters
Measurement procedures (if any):	Steam flow meter that automatically measures temperature and pressure of the steam. Accuracy of temperature measurement has to be 0.25% of the measured value or better. Read outs shall occur with the frequency of the plant control system but the frequency should not be lower than once per minute
Monitoring frequency:	Recording frequency: Hourly Monitoring frequency: Monthly
QA/QC procedures:	Steam flow meters should be calibrated as per internal QA/QC procedures of the plant
Any comment:	This monitored parameter is required in order to comply with the following applicability condition: <ul style="list-style-type: none"> A water steam chart or appropriate software according to international standard (for example IAPWS-IF 97) is used to calculate the properties of water and steam (e.g. enthalpies, entropies) from the measured pressure and temperature. This parameter will be used to calculate specific entropy or specific enthalpy of the high pressure steam during hour x

Data / Parameter:	$T_{LP,x}$
Data unit:	°C
Description:	Average temperature of the low pressure steam during hour x
Source of data:	Read out of measurement data from the plant control system and transfer to a data acquisition system with evaluation database and data storage for recording and reporting of monitored parameters
Measurement procedures (if any):	Steam flow meter that automatically measures temperature and pressure of the steam. Accuracy of temperature measurement has to be 0.25% of the measured value or better. Read outs shall occur with the frequency of the plant control system but the frequency should not be lower than once per minute
Monitoring frequency:	Recording frequency: Hourly Monitoring frequency: Monthly
QA/QC procedures:	Steam flow meters should be calibrated as per internal QA/QC procedures of the plant
Any comment:	This monitored parameter is required in order to comply with the following applicability condition: <ul style="list-style-type: none"> A water steam chart or appropriate software according to international standard (for example IAPWS-IF 97) is used to calculate the properties of water and steam (e.g. enthalpies, entropies) from the measured pressure and temperature. This parameter will be used to calculate specific entropy or specific enthalpy of the low pressure steam during hour x

Data / Parameter:	$T_{SSG,x}$
Data unit:	$^{\circ}C$
Description:	Average temperature of the steam leaving the solar steam generator during hour x
Source of data:	Plant record Read out of measurement data from the plant control system and transfer to a data acquisition system with evaluation database and data storage for recording and reporting of monitored parameters
Measurement procedures (if any):	Steam flow meter that automatically measures temperature and pressure of the steam. Accuracy of temperature measurement has to be 0.25% of the measured value or better. Read outs shall occur with the frequency of the plant control system but the frequency should not be lower than once per minute
Monitoring frequency:	Recording frequency: Hourly Monitoring frequency: Monthly
QA/QC procedures:	Steam flow meters should be calibrated as per internal QA/QC procedures of the plant
Any comment:	This monitored parameter is required in order to comply with the following applicability condition: <ul style="list-style-type: none"> A water steam chart or appropriate software according to international standard (for example IAPWS-IF 97) is used to calculate the properties of water and steam (e.g. enthalpies, entropies) from the measured pressure and temperature. This parameter will be used to calculate specific entropy or specific enthalpy of the steam leaving the solar steam generator during hour x

Data / Parameter:	$T_{0,x}$
Data unit:	$^{\circ}K$
Description:	Average temperature of the water at the condenser outlet during hour x
Source of data:	Plant record Read out of measurement data from the plant control system and transfer to a data acquisition system with evaluation database and data storage for recording and reporting of monitored parameters
Measurement procedures (if any):	Thermometer that automatically measures temperature of the steam. Accuracy of temperature measurement has to be 0.25% of the measured value or better. Read outs shall occur with the frequency of the plant control system but the frequency should not be lower than once per minute
Monitoring frequency:	Recording frequency: Hourly Monitoring frequency: Monthly
QA/QC procedures:	Thermometers should be calibrated as per internal QA/QC procedures of the plant
Any comment:	This monitored parameter is required in order to comply with the following applicability condition: <ul style="list-style-type: none"> A water steam chart or appropriate software according to international standard (for example IAPWS-IF 97) is used to calculate the properties of water and steam (e.g. enthalpies, entropies) from the measured pressure and temperature. This parameter will also be used to calculate specific entropy or specific enthalpy of the water at the condenser outlet during hour x

Data / Parameter:	$p_{HP,x}$
Data unit:	bar
Description:	Average pressure of the high pressure steam during hour x
Source of data:	Plant record Read out of measurement data from the plant control system and transfer to a data acquisition system with evaluation database and data storage for recording and reporting of monitored parameters
Measurement procedures (if any):	Steam flow meter that automatically measures temperature and pressure of the steam. Accuracy of pressure measurement has to be 0.3% of the measurement range of the meter or better. Read outs shall occur with the frequency of the plant control system but the frequency should not be lower than once per minute
Monitoring frequency:	Recording frequency: Hourly Monitoring frequency: Monthly
QA/QC procedures:	Steam flow meters should be calibrated as per internal QA/QC procedures of the plant
Any comment:	This monitored parameter is required in order to comply with the following applicability condition: <ul style="list-style-type: none"> A water steam chart or appropriate software according to international standard (for example IAPWS-IF 97) is used to calculate the properties of water and steam (e.g. enthalpies, entropies) from the measured pressure and temperature. This parameter will be used to calculate specific entropy or specific enthalpy of the high pressure steam during hour x

Data / Parameter:	$p_{LP,x}$
Data unit:	bar
Description:	Average pressure of the low pressure steam during hour x
Source of data:	Plant record Read out of measurement data from the plant control system and transfer to a data acquisition system with evaluation database and data storage for recording and reporting of monitored parameters
Measurement procedures (if any):	Steam flow meter that automatically measures temperature and pressure of the steam. Accuracy of pressure measurement has to be 0.3% of the measurement range of the meter or better. Read outs shall occur with the frequency of the plant control system but the frequency should not be lower than once per minute
Monitoring frequency:	Recording frequency: Hourly Monitoring frequency: Monthly
QA/QC procedures:	Steam flow meters should be calibrated as per internal QA/QC procedures of the plant
Any comment:	This monitored parameter is required in order to comply with the following applicability condition: <ul style="list-style-type: none"> A water steam chart or appropriate software according to international standard (for example IAPWS-IF 97) is used to calculate the properties of water and steam (e.g. enthalpies, entropies) from the measured pressure and temperature. This parameter will be used to calculate specific entropy or specific enthalpy of the low pressure steam during hour x

Data / Parameter:	$p_{SSG,x}$
Data unit:	bar
Description:	Average pressure of the steam leaving the solar steam generator during hour x
Source of data:	Plant record Read out of measurement data from the plant control system and transfer to a data acquisition system with evaluation database and data storage for recording and reporting of monitored parameters
Measurement procedures (if any):	Steam flow meter that automatically measures temperature and pressure of the steam. Accuracy of pressure measurement has to be 0.3% of the measurement range of the meter or better. Read outs shall occur with the frequency of the plant control system but the frequency should not be lower than once per minute
Monitoring frequency:	Recording frequency: Hourly Monitoring frequency: Monthly
QA/QC procedures:	Steam flow meters should be calibrated as per internal QA/QC procedures of the plant
Any comment:	This monitored parameter is required in order to comply with the following applicability condition: <ul style="list-style-type: none"> A water steam chart or appropriate software according to international standard (for example IAPWS-IF 97) is used to calculate the properties of water and steam (e.g. enthalpies, entropies) from the measured pressure and temperature. This parameter will be used to calculate specific entropy or specific enthalpy of the steam leaving the solar steam generator during hour x

Data / Parameter:	$p_{0,x}$
Data unit:	bar
Description:	Average pressure of the water at the condenser outlet during hour x
Source of data:	Plant record Read out of measurement data from the plant control system and transfer to a data acquisition system with evaluation database and data storage for recording and reporting of monitored parameters
Measurement procedures (if any):	Water pressure meter that automatically measure pressure of the water. Accuracy of pressure measurement has to be 0.3% of the measurement range of the meter or better. Read outs shall occur with the frequency of the plant control system but the frequency should not be lower than once per minute
Monitoring frequency:	Recording frequency: Hourly Monitoring frequency: Monthly
QA/QC procedures:	Water pressure meters should be calibrated as per internal QA/QC procedures of the plant
Any comment:	This monitored parameter is required in order to comply with the following applicability condition: <ul style="list-style-type: none"> A water steam chart or appropriate software according to international standard (for example IAPWS-IF 97) is used to calculate the properties of water and steam (e.g. enthalpies, entropies) from the measured pressure and temperature. This parameter will be used to calculate specific entropy or specific enthalpy of the water at the condenser outlet during hour x

Data / Parameter:	$h_{HP,x}$
Data unit:	kJ/kg
Description:	Average specific enthalpy of the high pressure steam entering the steam turbine during hour x
Source of data:	Calculation from water steam chart or appropriate software according to international standard (for example IAPWS-IF 97) and transfer to data acquisition system with evaluation database and data storage for recording and reporting of monitored parameters
Measurement procedures (if any):	Not relevant
Monitoring frequency:	Recording frequency: Hourly Monitoring frequency: Monthly
QA/QC procedures:	As per internal QA/QC procedures of the plant
Any comment:	-

Data / Parameter:	$m_{HP,x}$
Data unit:	kg
Description:	Mass flow of the high pressure steam entering the steam turbine during hour x
Source of data:	Plant record Read out of measurement data from the plant control system and transfer to a data acquisition system with evaluation database and data storage for recording and reporting of monitored parameters
Measurement procedures (if any):	Steam flow meter that automatically measures temperature and pressure of the steam. Accuracy of mass flow measurement has to be 1% of the measured value or better for the range from 30% to 100% of maximum mass flow and 3% of the measured value or better for mass flows below this range. Read outs shall occur with the frequency of the plant control system but the frequency should not be lower than once per minute
Monitoring frequency:	Recording frequency: Hourly Monitoring frequency: Monthly
QA/QC procedures:	Steam flow meters should be calibrated as per internal QA/QC procedures of the plant
Any comment:	-

Data / Parameter:	$m_{LP,x}$
Data unit:	kg
Description:	Mass flow of low pressure steam entering the steam turbine during hour x
Source of data:	Plant record Read out of measurement data from the plant control system and transfer to a data acquisition system with evaluation database and data storage for recording and reporting of monitored parameters
Measurement procedures (if any):	Steam flow meter that automatically measures temperature and pressure of the steam. Accuracy of mass flow measurement has to be 1% of the measured value or better for the range from 30% to 100% of maximum mass flow and 3% of the measured value or better for mass flows below this range. Read outs shall occur with the frequency of the plant control system but the frequency should not be lower than once per minute
Monitoring frequency:	Recording frequency: Hourly Monitoring frequency: Monthly
QA/QC procedures:	Steam flow meters should be calibrated as per internal QA/QC procedures of the plant
Any comment:	-

Data / Parameter:	$m_{SSG,x}$
Data unit:	kg
Description:	Mass flow of the steam leaving the solar steam generator during hour x
Source of data:	Plant record Read out of measurement data from the plant control system and transfer to a data acquisition system with evaluation database and data storage for recording and reporting of monitored parameters
Measurement procedures (if any):	Steam flow meter that automatically measures temperature and pressure of the steam. Accuracy of mass flow measurement has to be 1% of the measured value or better for the range from 30% to 100% of maximum mass flow and 3% of the measured value or better for mass flows below this range. Read outs shall occur with the frequency of the plant control system but the frequency should not be lower than once per minute
Monitoring frequency:	Recording frequency: Hourly Monitoring frequency: Monthly
QA/QC procedures:	Steam flow meters should be calibrated as per internal QA/QC procedures of the plant
Any comment:	-

Data / Parameter:	$EG_{GT, gross, y}$
Data unit:	MWh
Description:	Gross electricity generation from gas turbine measured at the generator terminal in year y
Source of data:	Plant record Measurement at gas turbine generator terminal
Measurement procedures (if any):	Accuracy in accordance with the grid code/transmission code of the grid to which the power plant is connected. If such a code is not applied then an accuracy class 0.2 shall be required. Current transformer and voltage transformer in accordance with the grid code/transmission code of the grid to which the power plant is connected
Monitoring frequency:	Monitoring frequency: Monthly Aggregated to yearly value
QA/QC procedures:	In accordance with the internal QA/QC procedures of the plant and the grid code/transmission code of the grid to which the power plant is connected
Any comment:	-

Data / Parameter:	$EG_{ISCC, y}$
Data unit:	MWh
Description:	Net electricity generation from the ISCC measured at the substation deducted by all electricity purchased from the grid in year y
Source of data:	Plant record Meter at the substation to which the power plant is connected
Measurement procedures (if any):	Accuracy in accordance with the grid code/transmission code of the grid to which the power plant is connected. If such a code is not applied then an accuracy class 0.2 shall be required. Current transformer and voltage transformer in accordance with the grid code/transmission code of the grid to which the power plant is connected
Monitoring frequency:	Monitoring frequency: Monthly Aggregated to yearly value
QA/QC procedures:	In accordance with the internal QA/QC procedures of the plant and the grid code/transmission code of the grid to which the power plant is connected. Cross-check with receipts from electricity sales
Any comment:	-

Data / Parameter:	$EC_{SF,y}$
Data unit:	MWh
Description:	Electricity consumption of the solar field in year y
Source of data:	Plant record
Measurement procedures (if any):	Electricity meters have to be installed at electrical interconnection points of the internal power supply to the Solar Field. In case a metering of several consumers together at an interconnection point is not possible, consumers have to be metered individually Alternatively it shall be assumed that all relevant electrical equipment operate at full rated capacity, plus 10% to account for distribution losses, for 8760 hours per annum Accuracy class 0.5 shall be required. Current transformer and voltage transformer in accordance with the grid code/transmission code of the grid to which the power plant is connected
Monitoring frequency:	Annually
QA/QC procedures:	As per internal QA/QC procedures of the plant
Any comment:	-

Data / Parameter:	$m_{i,v}$
Data unit:	ton or m^3
Description:	Mass/volume of supplementary fuel i combusted in year y
Source of data:	Plant record
Measurement procedures (if any):	Use either mass or volume meters
Monitoring frequency:	Recording frequency: Daily Monitoring frequency: Monthly Aggregated to yearly value
QA/QC procedures:	The consistency of metered fuel consumption quantities should be cross-checked by an annual energy balance that is based on purchased quantities and stock changes
Any comment:	-

Data / Parameter:	NCV _{i,y}	
Data unit:	TJ/ton or m ³	
Description:	Net calorific value of the fuel <i>i</i> in year <i>y</i>	
Source of data:	The following data sources may be used if the relevant conditions apply:	
	Data source	Conditions for using the data source
	a) Values provided by the fuel supplier for example in invoices	This is the preferred source
	b) Measurements by the project participants	If a) is not available
	c) Regional or national default values	If b) is not available These sources can only be used for liquid fuels and should be based on well documented, reliable sources (such as national energy balances).
	d) IPCC default values at the lower limit of the uncertainty at a 95% confidence interval as provided in Table 1.2 of Chapter 1 of Vol. 2 (Energy) of the 2006 IPCC Guidelines on National GHG Inventories	If c) is not available
Measurement procedures (if any):	For a) and b): Measurements should be undertaken in line with national or international fuel standards	
Monitoring frequency:	For a) and b): The NCV should be obtained for each fuel delivery, from which weighted average annual values should be calculated For c): Review appropriateness of the values annually For d): Any future revision of the IPCC Guidelines should be taken into account	
QA/QC procedures:	Verify if the values under a), b) and c) are within the uncertainty range of the IPCC default values as provided in Table 1.2, Vol. 2 of the 2006 IPCC Guidelines. If the values fall below this range collect additional information from the testing laboratory to justify the outcome or conduct additional measurements. The laboratories in a), b) or c) should have ISO17025 accreditation or justify that they can comply with similar quality standards	
Any comment:	-	

Data / Parameter:	$EF_{i,y}$										
Data unit:	tCO ₂ /TJ										
Description:	Emission factor of the supplementary fuel <i>i</i> combusted in year <i>y</i>										
Source of data:	The following data sources may be used if the relevant conditions apply: <table border="1" data-bbox="475 398 1449 1084"> <thead> <tr> <th>Data source</th> <th>Conditions for using the data source</th> </tr> </thead> <tbody> <tr> <td>a) Values provided by the fuel supplier for example in invoices</td> <td>This is the preferred source</td> </tr> <tr> <td>b) Measurements by the project participants</td> <td>If a) is not available</td> </tr> <tr> <td>c) Regional or national default values</td> <td>If b) is not available These sources can only be used for liquid fuels and should be based on well-documented, reliable sources (such as national energy balances)</td> </tr> <tr> <td>d) IPCC default values at the lower limit of the uncertainty at a 95% confidence interval as provided in table 1.4 of Chapter 1 of Vol. 2 (Energy) of the 2006 IPCC Guidelines on National GHG Inventories</td> <td>If c) is not available</td> </tr> </tbody> </table>	Data source	Conditions for using the data source	a) Values provided by the fuel supplier for example in invoices	This is the preferred source	b) Measurements by the project participants	If a) is not available	c) Regional or national default values	If b) is not available These sources can only be used for liquid fuels and should be based on well-documented, reliable sources (such as national energy balances)	d) IPCC default values at the lower limit of the uncertainty at a 95% confidence interval as provided in table 1.4 of Chapter 1 of Vol. 2 (Energy) of the 2006 IPCC Guidelines on National GHG Inventories	If c) is not available
Data source	Conditions for using the data source										
a) Values provided by the fuel supplier for example in invoices	This is the preferred source										
b) Measurements by the project participants	If a) is not available										
c) Regional or national default values	If b) is not available These sources can only be used for liquid fuels and should be based on well-documented, reliable sources (such as national energy balances)										
d) IPCC default values at the lower limit of the uncertainty at a 95% confidence interval as provided in table 1.4 of Chapter 1 of Vol. 2 (Energy) of the 2006 IPCC Guidelines on National GHG Inventories	If c) is not available										
Measurement procedures (if any):	For a) and b): Measurements should be undertaken in line with national or international fuel standards										
Monitoring frequency:	For a) and b): The CO ₂ emission factor should be obtained for each fuel delivery, from which weighted average annual values should be calculated. For c): Review appropriateness of the values annually For d): Any future revision of the IPCC Guidelines should be taken into account										
QA/QC procedures:	-										
Any comment:	-										

Data / Parameter:	$\eta_{E,sup,y}$
Data unit:	-
Description:	Efficiency of HRSG which converts energy in the supplementary fuel to steam (to calculate energy from the supplementary firing)
Source of data:	Default value or measurement from the project participants.
Measurement procedures (if any):	<u>Option 1</u> Default efficiency of 0.6 <u>Option 2</u> Measurement using national or international standards
Monitoring frequency:	Monitoring frequency: Monthly Aggregated to yearly value
QA/QC procedures:	As per QA/QC procedures of national or international standards
Any comment:	-

Data / Parameter:	$\eta_{EF, sup, y}$
Data unit:	-
Description:	Efficiency of HRSG which converts energy in the supplementary fuel to steam (for emission factor of electricity generation from the supplementary firing)
Source of data:	Default value or measurement from the project participants.
Measurement procedures (if any):	<u>Option 1</u> Default efficiency of 1.0 <u>Option 2</u> Measurement using national or international standards
Monitoring frequency:	Monitoring frequency: Monthly Aggregated to yearly value
QA/QC procedures:	As per QA/QC procedures of national or international standards
Any comment:	-

Data and parameters calculated

The following parameters shall be calculated based on the monitored data and parameters above:

Data / Parameter:	$h_{LP, x}$
Data unit:	kJ/kg
Description:	Average specific enthalpy of the low pressure steam entering the steam turbine during hour x
Source of data:	Calculation from water steam chart or appropriate software according to international standard (for example IAPWS-IF 97) and transfer to data acquisition system with evaluation database and data storage for recording and reporting of monitored parameters
Measurement procedures (if any):	Not relevant
Monitoring frequency:	Recording frequency: Hourly Monitoring frequency: Monthly
QA/QC procedures:	As per internal QA/QC procedures of the plant
Any comment:	-

Data / Parameter:	$h_{SSG, x}$
Data unit:	kJ/kg
Description:	Average specific enthalpy of the steam leaving the solar steam generator during hour x
Source of data:	Calculation from water steam chart or appropriate software according to international standard (for example IAPWS-IF 97) and transfer to data acquisition system with evaluation database and data storage for recording and reporting of monitored parameters
Measurement procedures (if any):	Not relevant
Monitoring frequency:	Recording frequency: Hourly Monitoring frequency: Monthly
QA/QC procedures:	As per internal QA/QC procedures of the plant
Any comment:	-

Data / Parameter:	$h_{0,x}$
Data unit:	kJ/kg
Description:	Average specific enthalpy of the water at the condenser outlet during hour x
Source of data:	Calculation from water steam chart or appropriate software according to international standard (for example IAPWS-IF 97) and transfer to data acquisition system with evaluation database and data storage for recording and reporting of monitored parameters
Measurement procedures (if any):	Not relevant
Monitoring frequency:	Recording frequency: Hourly Monitoring frequency: Monthly
QA/QC procedures:	As per internal QA/QC procedures of the plant
Any comment:	-

Data / Parameter:	$S_{HP,x}$
Data unit:	kJ/kgK
Description:	Average specific entropy of the high pressure steam entering the steam turbine during hour x
Source of data:	Calculation from water steam chart or appropriate software according to international standard (for example IAPWS-IF 97) and transfer to data acquisition system with evaluation database and data storage for recording and reporting of monitored parameters
Measurement procedures (if any):	Not relevant
Monitoring frequency:	Recording frequency: Hourly Monitoring frequency: Monthly
QA/QC procedures:	As per internal QA/QC procedures of the plant
Any comment:	-

Data / Parameter:	$S_{LP,x}$
Data unit:	kJ/kgK
Description:	Average specific entropy of the low pressure steam during hour x
Source of data:	Calculation from water steam chart or appropriate software according to international standard (for example IAPWS-IF 97) and transfer to data acquisition system with evaluation database and data storage for recording and reporting of monitored parameters
Measurement procedures (if any):	Not relevant
Monitoring frequency:	Recording frequency: Hourly Monitoring frequency: Monthly
QA/QC procedures:	As per internal QA/QC procedures of the plant
Any comment:	-

Data / Parameter:	$S_{SSG,x}$
Data unit:	kJ/kgK
Description:	Average specific entropy of the steam leaving the solar steam generator during hour x
Source of data:	Calculation from water steam chart or appropriate software according to international standard (for example IAPWS-IF 97) and transfer to data acquisition system with evaluation database and data storage for recording and reporting of monitored parameters
Measurement procedures (if any):	Not relevant
Monitoring frequency:	Recording frequency: Hourly Monitoring frequency: Monthly
QA/QC procedures:	As per internal QA/QC procedures of the plant
Any comment:	-

Data / Parameter:	$S_{0,x}$
Data unit:	kJ/kgK
Description:	Average specific entropy of the water at the condenser outlet during hour x
Source of data:	Calculation from water steam chart or appropriate software according to international standard (for example IAPWS-IF 97) and transfer to data acquisition system with evaluation database and data storage for recording and reporting of monitored parameters
Measurement procedures (if any):	Not relevant
Monitoring frequency:	Recording frequency: Hourly Monitoring frequency: Monthly
QA/QC procedures:	As per internal QA/QC procedures of the plant
Any comment:	-

IV. REFERENCES AND ANY OTHER INFORMATION

Not applicable.

History of the document

Version	Date	Nature of revision(s)
01.0.0	EB 65, Annex # 25 November 2011	To be considered at EB 65.
Decision Class: Regulatory Document Type: Standard Business Function: Methodology		