

**Draft revision** to the approved baseline and monitoring methodology AM0053**“Biogenic methane injection to a natural gas distribution grid”****I. SOURCE AND APPLICABILITY****Source**

This baseline and monitoring methodology is based on elements from the following proposed new methodology:

- NM0210 “Biogenic methane injection to a natural gas distribution grid” submitted by Metrogas S. A., Chile whose baseline study and project design document were prepared by CO2e.com.

This methodology also refers to:

- “Tool to calculate project or leakage CO<sub>2</sub> emissions from fossil fuel combustion”;
- “Tool to calculate baseline, project and/or leakage emissions from electricity consumption”
- “Tool to determine project emissions from flaring gases containing methane”;
- “Tool for the demonstration and assessment of additionality”;
- “Combined tool to identify the baseline scenario and demonstrate additionality”.<sup>1</sup>

For more information regarding the proposed new methodology and the tools as well as their consideration by the Executive Board please refer to <<http://cdm.unfccc.int/goto/MPappmeth>>.

**Selected approach from paragraph 48 of the CDM modalities and procedures**

“Existing actual or historical emissions, as applicable”

**Applicability**

The methodology is applicable to project activities that process and upgrade biogas to the quality of natural gas and distributes it as energy via natural gas distribution grid. The source of biogas, which is generated by an anaerobic decomposition of organic matter, could be landfills, liquid waste treatment, animal waste management systems, etc.

The methodology is applicable under the following conditions:

- The biogas used in the project activity was either vented or flared prior to implementation of the project activity and would continue to be either vented or flared in the absence of the project

---

<sup>1</sup> Please refer to <<http://cdm.unfccc.int/goto/MPappmeth>>.



- activity. The project participants shall demonstrate this through documented evidence of venting or flaring prior to implementation of the project activity;
- The geographical extent of the natural gas distribution grid is within the host country boundaries;
  - The following technologies<sup>2</sup> are used to upgrade biogas to natural gas quality:
    - Pressure Swing Adsorption; or
    - Absorption with/without water circulation;
    - Absorption with Water, with or without water recirculation;

Note:

- If the source of biogas is another registered CDM project activity, the details of the registered CDM project activity shall be provided in the CDM-PDD;
- The approved methodology can be used in conjunction with approved methodologies for capture and destruction/use of biomethane, such as ACM0001, AM0013, AM0025, ACM0014, etc. In such cases the baseline scenario identification procedure and additionality assessment shall be undertaken for the combination of the two components of the project activity, i.e., biomethane emission avoidance and displacement of natural gas.

## II. BASELINE METHODOLOGY

### Project boundary

The project boundary encompasses the following:

- The biogas upgrading facility;
- The pipeline supplying biogas from the source (a landfill, a liquid waste treatment facility, etc.), to the upgrading facility;
- The source facility where the gas is generated;
- The natural gas distribution grid, i.e., the system of pipelines that distribute gas without significant transmission constraints, and all the facilities and devices connected directly to it.

---

<sup>2</sup> Please see annex I for description of the technologies.

**Table 1: Emissions sources included in or excluded from the project boundary:**

|                         | Source  | Gas              | Included? | Justification / Explanation   |
|-------------------------|---|------------------|-----------|---|
| <b>Baseline</b>         | Natural gas distribution grid   | CO <sub>2</sub>  | Yes       | The methodology assumes that all the natural gas consumed in the grid is combusted, emitting carbon dioxide                   |
|                         |   | CH <sub>4</sub>  | No        | Emissions due to grid leakage or venting are not considered since they will not change with the implementation of the project |
|                         |   | N <sub>2</sub> O | No        | Emissions of this gas are considered negligible from this source  |
| <b>Project Activity</b> | Energy consumption of: the gas transport from source to the upgrading facility; upgrading process; and transport to the natural gas grid injection point. | CO <sub>2</sub>  | Yes       | Emissions produced by the use of energy to upgrade and transport biogas   |
|                         |   | CH <sub>4</sub>  | No        | Emissions of this gas are considered negligible from this source  |
|                         |   | N <sub>2</sub> O | No        | Emissions of this gas are considered negligible from this source  |
|                         | Flaring of vent gas   | CO <sub>2</sub>  | No        | Emissions of CO <sub>2</sub> e from this source are considered as baseline  |
|                         |   | CH <sub>4</sub>  | Yes       | Included  |
|                         |   | N <sub>2</sub> O | No        | Emissions of this gas are considered negligible from this source  |
|                         | Methane contained in the effluent   | CO <sub>2</sub>  | No        | Emissions of this gas are considered negligible from this source  |
|                         |   | CH <sub>4</sub>  | Yes       | Included  |
|                         |   | N <sub>2</sub> O | No        | The emissions of this gas are considered negligible from this source  |

**Procedure for the identification of the most plausible baseline scenario**

The most plausible baseline scenario is identified through the application of the steps described below.

***Step 1: Identify all realistic and credible alternative scenarios to the proposed project activity and eliminate alternatives that do not comply with legal or regulatory requirements***

The plausible alternative scenarios for the use of biogas shall include, but not limited to:

- Biogas is vented into the atmosphere;
- Biogas is captured and flared;
- Biogas is captured and used to produce electricity and/or thermal energy;
- Biogas is captured and used as feedstock or transportation fuel;
- The proposed project activity undertaken without being registered as a CDM project activity.



For the purpose of identifying relevant alternative scenarios, provide an overview of other practices for use of biogas that have been implemented previously or are currently underway in the relevant geographical area. The relevant geographical area should in principle be the host country of the proposed CDM project activity. A region within the country could be the relevant geographical area if the framework conditions vary significantly within the country. However, the relevant geographical area should include preferably ten facilities (or projects) that provide outputs or services with comparable quality, properties and application areas as the proposed CDM project activity. If less than ten facilities (or projects) that provide outputs or services with comparable quality, properties and application areas as the proposed CDM project activity are found in the region/host country, the geographical area may be expanded to an area that covers if possible, ten such facilities (or projects).

In cases where the above described definition of geographical area is not suitable, the project proponents should provide an alternative definition of geographical area. Other registered CDM project activities are not to be included in this analysis. Provide relevant documentation to support the results of the analysis.

The alternatives to the project activity shall be in compliance with all applicable legal and regulatory requirements even if these laws and regulations have objectives other than GHG reductions, e.g., to mitigate local air pollution.

If an alternative does not comply with all applicable legislation and regulations, eliminate such alternative unless it is demonstrated, based on an examination of current practice in the country or region in which the law or regulation applies, that applicable legal or regulatory requirements are systematically not enforced and that non-compliance is widespread.

### ***Step 2: Eliminate alternatives that face prohibitive barriers***

Scenarios that face prohibitive barriers should be eliminated by applying “Step 2 - Barrier analysis” of the latest version of the “Combined tool to identify the baseline scenario and demonstrate additionality” agreed by the CDM Executive Board.

- If there is only one alternative scenario that is not prevented by any barrier, and if this alternative is not the proposed project activity undertaken without being registered as a CDM project activity, then this alternative scenario is identified as the baseline scenario.
- If there are still several alternative scenarios remaining project participants may choose to either:
  - Option 1: Go to step 3 (investment analysis), or
  - Option 2: Identify the alternative with the lowest emissions (i.e. the most conservative) as the baseline scenario.

### ***Step 3: Conduct an investment analysis***

Compare the economic attractiveness without revenues from CERs for alternatives that are remaining by applying “Step 3 - Investment analysis” of the latest version of the “Combined tool to identify the baseline scenario and demonstrate additionality” agreed by the CDM Executive Board.

- If the sensitivity analysis is not conclusive, identify the alternative with the lowest emissions (i.e. the most conservative);



- If the sensitivity analysis confirms the result of the investment comparison analysis, then the most economically or financially attractive alternative scenario is considered as baseline scenario.

Note: The methodology is only applicable if the identified baseline scenario is venting or flaring of biogas at the site where it is captured.

### Additionality

The additionality of the project activity shall be demonstrated and assessed using the latest version of the “Tool for the demonstration and assessment of additionality” approved by the CDM Executive Board and available on the UNFCCC CDM website.

### Baseline emissions

Baseline emissions are estimated as follows:

$$BE_y = E_{ug,y} * CEF_{NG} \quad (1)$$

Where:

- $BE_y$  = Baseline emissions in year  $y$  (tCO<sub>2</sub>e)  
 $E_{ug,y}$  = Energy delivered from the upgraded biogas in the project activity to the natural gas distribution grid in year  $y$  (TJ)  
 $CEF_{NG}$  = Carbon emission factor of the natural gas (tCO<sub>2</sub>e/TJ)

$$E_{ug,y} = Q_{ug,y} * NCV_{ug,y} \quad (2)$$

Where:

- $Q_{ug,y}$  = Quantity of upgraded biogas displacing the use of natural gas in the natural gas distribution grid in year  $y$ , in (kg) or (m<sup>3</sup>)  
 $NCV_{ug,y}$  = Net calorific value of the upgraded biogas in year  $y$ , in (TJ/kg) or in (TJ/m<sup>3</sup>)

$$Q_{ug,y} = \min^m(Q_{ug,in,y}, Q_{cap,CH4,y}) \quad (3)$$

Where:

- $Q_{ug,in,y}$  = Quantity of upgraded biogas injected into the natural gas distribution grid in year  $y$ , in (kg) or (m<sup>3</sup>)  
 $Q_{cap,CH4,y}$  = Quantity of methane in the Biogas captured at the source in year  $y$ , in (kg) or (m<sup>3</sup>)

$$Q_{cap,CH4,y} = w_{CH4} * Q_{cap,bg,y} \quad (4)$$

Where:

- $Q_{cap,bg,y}$  = Quantity of biogas captured at the source facility(ies), in (kg) or (m<sup>3</sup>)  
 $w_{CH4}$  = methane fraction of biogas as monitored at the outlet of the source facility(ies) kg or m<sup>3</sup> CH<sub>4</sub>/kg or m<sup>3</sup> of biogas



For ex-ante estimation of baseline emissions the project participants shall assume  $Q_{ug}$  = quantity of gas vented or captured and flared as per the available historic data. If historic data is not available the quantity vented or flared will be estimated.

### Project emissions

The project emissions will be calculated as follows:

$$PE_y = PE_{ugf,elec,y} + PE_{ugf,fuel,y} + PE_{flare,y} + P_{Event,y} + P_{Eww,y} \quad (5)$$

Where:

- $PE_{ugf,elec,y}$  = Project emissions due to electricity consumption of the project activity in year  $y$  in (tCO<sub>2</sub>e) for upgrading the gas
- $PE_{ugf,fuel,y}$  = Project emissions due to fossil fuel(s) consumption by the project activity in year  $y$  in (tCO<sub>2</sub>e) to upgrade and transport gas
- $PE_{flare,y}$  = Project emissions from flaring of the residual gas stream in year  $y$  in (tCO<sub>2</sub>e)
- $PE_{ww,y}$  = Project emissions due to the methane contained in the effluent in year  $y$

#### 1. Emissions due to energy consumption of the upgrading facility

Note: The electricity and fossil fuel use (other than the biogas) for pumping the biogas from source site to the upgrading facility and upgrading facility to the point of injection into the natural gas distribution grid should be included in the estimation of project emissions.

##### a) Emissions due to electricity consumption

$$PE_{ugf,elec,y} = PE_{EC,y} \quad (6)$$

The CO<sub>2</sub> emissions from electricity generation in the project plant ( $PE_{EC,y}$ ) should be calculated using the latest approved version of the “Tool to calculate baseline, project and/or leakage emissions from electricity consumption”

##### b) Emissions due to fossil fuel(s) consumption

$$PE_{ugf,fuel,y} = PE_{FC,j,y} \quad (7)$$

The CO<sub>2</sub> emissions from fossil fuel consumption in the project activity ( $PE_{FC,j,y}$ ) should be calculated using the latest approved version of the “Tool to calculate project or leakage CO<sub>2</sub> emissions from fossil fuel combustion”, where the process  $j$  in the tool corresponds to the combustion of fossil fuels in the project activity for operating the biogas upgrading activity and transportation of the biogas.

#### 2. Methane emissions in vent gases

In the cases where vent gases are flared, emissions due to the incomplete or inefficient combustion of the gases from the desorption column will be calculated using the latest version of the methodological “Tool to determine project emissions from flaring gases containing methane”, as follows:

$$PE_{flare,y} = \sum_{h=1}^{8760} TM_{RG,h} * (1 - \eta_{flare,h}) * \frac{GWP_{CH4}}{1000} \tag{8}$$

Where:

- $TM_{RG,h}$  = Mass flow rate of the residual gas in hour  $h$  in (kg/h)
- $\eta_{flare,h}$  = Flare efficiency in hour  $h$
- $GWP_{CH4}$  = Global Warming Potential of methane valid for the commitment period in tCO<sub>2</sub>e/tCH<sub>4</sub>

Detailed guidance for the calculation and measurement of the parameters shown above are contained in the “Tool to determine project emissions from flaring gases containing methane”.

When project participants decide not to flare the vent gases, monitoring procedures will be guided by the same methodological tool, without considering measurements and calculations for the flare efficiency, which will be assumed to be zero.

In this case, emissions due to the vent gases in the desorption column will be:

$$PE_{vent,y} = \sum_{h=1}^{8760} TM_{RG,h} * \frac{GWP_{CH4}}{1000} \tag{9}$$

### 3. Emissions of methane contained in the effluent

This is applicable to cases where the upgrading facility uses water absorption technology. It is assumed that all the methane contained in the wastewater is emitted to the atmosphere. The related project emissions are therefore calculated as follows:

$$PE_{ww,y} = Q_{ww,y} * [CH_4]_{ww} \tag{10}$$

Where:

- $Q_{ww,y}$  = Volume of wastewater produced in year  $y$
- $[CH_4]_{ww}$  = Dissolved methane contained in the wastewater in year  $y$

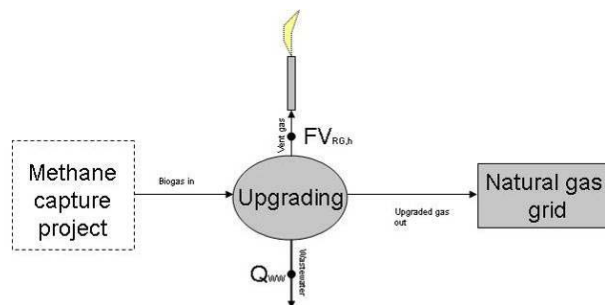

Figure 1: Emissions due to flare inefficiency and methane contained in the wastewater

Ex-ante estimations of project emissions

Ex-ante estimation of project emissions should be performed for the purpose of estimating annual emission reductions.

Project emissions due to the consumption of energy are to be estimated using the energy consumption estimates provided by the manufacturer. In the case of consumption of fossil fuels, default values of emission factors can be used. In the case of electricity consumption, the emission factor of the consumed electricity default value of 1.3 tCO<sub>2</sub>/MWh can be used.

Methane emissions from flaring of vent gas and from wastewater are estimated using the efficiency of the upgrading process, which equals to methane income divided by methane outcome in the upgrading facility. It is assumed that all the methane not injected to the natural gas distribution grid due to inefficiencies of the process will be flared or leave the upgrading process in wastewater.

In the case when methane not injected in the natural gas distribution grid is flared, the flare efficiency provided by the manufacturer should be used. In the case when methane not injected in the natural gas distribution grid leaves the upgrading facility in wastewater, it is assumed that 100% of that methane will be emitted to the atmosphere.

**Leakage**

No significant leakage is expected for this type of project activity under the applicability conditions stated, thus leakage can be ignored.

**Emission Reductions**

The emission reductions are calculated as follows:

$$ER_y = BL_y - PE_y \quad (11)$$

Where:

|        |   |  |
|--------|---|--|
| $ER_y$ | = | Emissions reductions of the project activity during the year $y$ in (tCO <sub>2</sub> e) |
| $BL_y$ | = | Baseline emissions during the year $y$ in (tCO <sub>2</sub> e)                           |
| $PE_y$ | = | Project emissions during the year $y$ in (tCO <sub>2</sub> e)                            |

**Changes required for methodology implementation in 2<sup>nd</sup> and 3<sup>rd</sup> crediting periods**

To request renewal of a crediting period project participants shall demonstrate that changes in local/national laws and regulations and/or their enforcement occurred during the past crediting period do not affect the continued validity of the baseline.

Project participants will also have to update emission factors for the fossil fuels combusted or for electricity used in the project activity.



**Data and parameters not monitored**

|                                  |   |
|----------------------------------|---|
| <b>Data / Parameter:</b>         | $GWP_{CH_4}$  |
| Data unit:                       | tCO <sub>2</sub> e/tCH <sub>4</sub>   |
| Description:                     | Global warming potential of CH <sub>4</sub>   |
| Source of data:                  | IPCC  |
| Measurement procedures (if any): | 21 for the first commitment period. Shall be updated according to any future COP/MOP decisions. |
| Any comment:                     |   |

|                                  |  |
|----------------------------------|--|
| <b>Data / Parameter:</b>         | $\eta_{uef}$   |
| Data unit:                       | -  |
| Description:                     | Nameplate efficiency of the upgrading facility   |
| Source of data:                  | Provided by the manufacturer   |
| Measurement procedures (if any): |  |
| Any comment:                     | Used to estimate the ex-ante estimate of upgraded biogas, as a product of plant efficiency and estimated amount of vented or flared gas. |

**III. MONITORING METHODOLOGY****Monitoring procedures**

The monitoring methodology is based on direct and continuous measurement of the input of energy from the project activity to the natural gas distribution grid; continuous measurement of the volume of wastewater produced if the technology chosen is Absorption with Water without recirculation; periodic measurements of the methane concentration in wastewater; consumption of energy by the upgrading facility; methane emissions in the vent gases; and the flare efficiency, as illustrated in figure 4.

For monitoring project emissions from consumption of electricity the guidance in the latest version of the “Tool to calculate baseline, project and/or leakage emissions from electricity consumption” should be applied. For monitoring project emissions from combustion of fossil fuels in the project plant the guidance in the latest approved version of the “Tool to calculate project or leakage CO<sub>2</sub> emissions from fossil fuel combustion” should be applied. For monitoring project emissions from flaring the guidance in the latest version of the “Tool to determine project emissions from flaring gases containing methane” regarding parameters to be monitored shall be used.

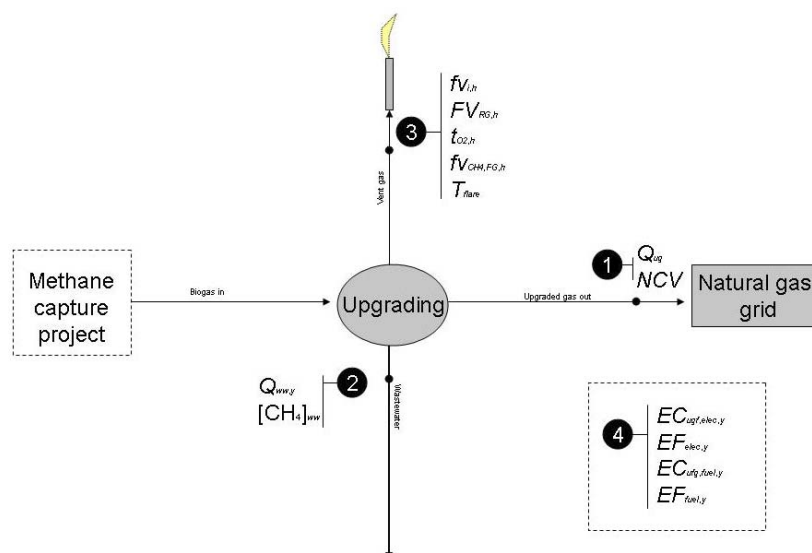

**Figure 2: Monitoring system**

### Gas-tightening condition

In order to assure that the gas-tightening condition is maintained during the operation of the upgrading plant, project participants should introduce the following practices aiming to systematically identify leaks and undertake necessary repairs:

- Project participants may use advanced tools to detect leaks in the upgrading facility, such as Electronic Screening with hand-held gas detectors or “sniffers”, Organic Vapor Analyzers (OVAs) and Toxic Vapor Analyzers (TVA), or Acoustic Leak Detection using acoustic screening devices;
- Project participants should test the gas-tightening condition at least once a month, and should maintain a detailed record of every survey including the name of a person who performed the test, the device used for the survey, detailed description of the test performed and follow-up actions to be taken;
- The test should cover the entire upgrading facility and should be performed by trained personnel using certified devices;
- Project participants should tag and number every leak identified and the related equipment should be repaired immediately; if necessary pieces of equipment should be replaced;
- Detailed schedule of the replacement of equipment provided by the manufacturer must be available; equipment should be replaced at least when required by the manufacturer.

If during the gas-tightening test major leaks are found, project participants should stop the upgrading process until the equipment is repaired.

Flaring of biogas by an “emergency flare” at the site of biogas capture

During the periods when the upgrading facility is closed due to the scheduled maintenance, reparation of equipment as described above, or other emergency, project participants should ensure that the captured biogas is flared at the site of its capture using the flare that was in operation prior to the start of the project activity. Appropriate monitoring procedures should be established to monitor this “emergency flare”.

**Data and parameters monitored**

|                                  |   |
|----------------------------------|---|
| <b>Data / Parameter:</b>         | $Q_{ug,in,y}$   |
| Data unit:                       | kg or $m^3$   |
| Description:                     | Quantity of upgraded biogas injected to the natural gas distribution grid in year $y$   |
| Source of data:                  | To be measured continuously by project participants using certified equipment   |
| Measurement procedures (if any): | If the chosen data unit is $m^3$ , project participants must measure pressure and temperature of the upgraded biogas injected to the natural gas distribution grid. This parameter should be measured under the same normal conditions as NCV |
| Monitoring frequency:            | Continuous  |
| QA/QC procedures:                | As recommended by the manufacturer  |
| Any comment:                     |   |

|                                  |  |
|----------------------------------|--|
| <b>Data / Parameter:</b>         | $Q_{cap,CH_4,y}$   |
| Data unit:                       | kg or $m^3$  |
| Description:                     | Quantity of methane in the Biogas captured at the source in year $y$ |
| Source of data:                  | Estimated from quantity of the biogas and methane content of biogas  |
| Measurement procedures (if any): |  |
| Monitoring frequency:            |  |
| QA/QC procedures:                |  |
| Any comment:                     |  |

|                                  |   |
|----------------------------------|---|
| <b>Data / Parameter:</b>         | $Q_{cap,bg,y}$  |
| Data unit:                       | kg or $m^3$   |
| Description:                     | Quantity of biogas captured at the source of biogas generation in year $y$  |
| Source of data:                  | To be measured continuously by project participants using certified equipment   |
| Measurement procedures (if any): | If the chosen data unit is $m^3$ , project participants must measure pressure and temperature of the upgraded biogas injected to the natural gas distribution grid. This parameter should be measured under the same normal conditions as NCV |
| Monitoring frequency:            | Continuous  |
| QA/QC procedures:                | As recommended by the manufacturer  |
| Any comment:                     | To be measured at the biogas generation facility  |



|                                  |  |
|----------------------------------|--|
| <b>Data / Parameter:</b>         | $W_{CH_4}$   |
| Data unit:                       | Fraction   |
| Description:                     | Concentration of methane in biogas in year $y$   |
| Source of data:                  | To be measured continuously by project participants using certified equipment  |
| Measurement procedures (if any): | Preferably measured by continuous gas quality analyser. Methane fraction of the landfill gas to be measured on wet basis |
| Monitoring frequency:            | Continuous   |
| QA/QC procedures:                | As recommended by the manufacturer   |
| Any comment:                     | To be measured at the biogas generation facility   |

|                                  |   |
|----------------------------------|---|
| <b>Data / Parameter:</b>         | $CEF_{NG}$  |
| Data unit:                       | $tCO_2/m^3$ or $tCO_2/t$  |
| Description:                     | GHG emission factor of natural gas in the natural gas distribution grid in year $y$   |
| Source of data:                  | Local, Regional, Global (IPCC)  |
| Measurement procedures (if any): | Project proponents may use accurate and reliable local or national data where available. Where such data are not available, default emission factors from IPCC-2006 guidelines may be used if they are deemed to reasonably represent local circumstances. All values should be chosen in a conservative manner (i.e. lower values should be chosen, for baseline emissions, within a plausible range) and the choice should be justified and documented in the CDM-PDD |
| Monitoring frequency:            | Annual  |
| QA/QC procedures:                |   |
| Any comment:                     |   |

|                                  |  |
|----------------------------------|--|
| <b>Data / Parameter:</b>         | $NCV_{ug, y}$  |
| Data unit:                       | $TJ/kg$ or $TJ/m^3$  |
| Description:                     | Net Calorific Value of upgraded injected biogas  |
| Source of data:                  | To be measured continuously by project participants using certified equipment  |
| Measurement procedures (if any): | Project participants should use an online Heating Value Meter to measure the NCV directly from the gas stream. The measurement must be in mass or volume basis, and project participants should ensure that units of the measurements of the amount of biogas injected and of the net calorific value are consistent |
| Monitoring frequency:            | Monthly  |
| QA/QC procedures:                | As recommended by the manufacturer   |
| Any comment:                     |  |



|                                  |  |
|----------------------------------|--|
| <b>Data / Parameter:</b>         | $Q_{bg,y}$   |
| Data unit:                       | kg or m <sup>3</sup>   |
| Description:                     | Quantity of biogas delivered to the upgrading facility from the biogas capture site in year $y$  |
| Source of data:                  | To be measured continuously by project participants using certified equipment  |
| Measurement procedures (if any): | If the chosen data unit is m <sup>3</sup> , project participants must measure pressure and temperature of biogas delivered to the upgrading facility |
| Monitoring frequency:            | Continuous   |
| QA/QC procedures:                | As recommended by the manufacturer   |
| Any comment:                     |  |

|                                  |   |
|----------------------------------|---|
| <b>Data / Parameter:</b>         | $EC_{ugf,elec,y}$   |
| Data unit:                       | MWh   |
| Description:                     | Electricity used in the project activity in year $y$  |
| Source of data:                  | Measured by project participants by digital control systems and/or data logs  |
| Measurement procedures (if any): | Project participants should use electrical energy meter or electricity bills  |
| Monitoring frequency:            | Continuously  |
| QA/QC procedures:                | Electrical Energy Meter used for measurement should be calibrated regularly as per ISO procedures or according to manufacturer's guidelines |
| Any comment:                     |   |

|                                  |   |
|----------------------------------|---|
| <b>Data / Parameter:</b>         | $FC_{f,y}$  |
| Data unit:                       | Tonnes or m <sup>3</sup>  |
| Description:                     | Annual quantity of fuel type 'f' consumed in the project activity   |
| Source of data:                  | Fuel flow meter reading at the upgrading facility   |
| Measurement procedures (if any): |   |
| Monitoring frequency:            | Recorded daily for fuel used in the project activity  |
| QA/QC procedures:                | All measurements should use calibrated measurement equipment. Fuel metering will be subject to regular (in accordance with stipulation of the meter supplier or relevant sectoral or national standards) maintenance and testing to ensure accuracy. The readings will be double checked by the purchase invoice. |
| Any comment:                     | The total fuel consumption will be monitored at the upgrading facility and the purchase invoice will be used for cross-verification   |



|                                  |   |
|----------------------------------|---|
| <b>Data / Parameter:</b>         | $Q_{ww,y}$  |
| Data unit:                       | $m^3$   |
| Description:                     | Volume of wastewater produced in year $y$   |
| Source of data:                  | Measured by project participants using certified equipment  |
| Measurement procedures (if any): |   |
| Monitoring frequency:            | Continuously  |
| QA/QC procedures:                | Flow meters are to be calibrated according to the manufacturer's recommendations                          |
| Any comment:                     | Measured only when the chosen technology to upgrade biogas is Absorption with Water without recirculation |

|                                  |   |
|----------------------------------|---|
| <b>Data / Parameter:</b>         | $[CH_4]_y$  |
| Data unit:                       | [tonnes $CH_4/m^3$ wastewater]  |
| Description:                     | $CH_4$ concentration in wastewater in year $y$  |
| Source of data:                  | Measured  |
| Measurement procedures (if any): | Measured by a certified company using certified analyzers   |
| Monitoring frequency:            | At least once every six months  |
| QA/QC procedures:                | Samples must be taken during normal operation of the upgrading facility.                                  |
| Any comment:                     | Measured only when the chosen technology to upgrade biogas is Absorption with Water without recirculation |

## ANNEX I

### Description of Technologies to which the methodology is applicable

#### Pressure Swing Adsorption

This technology is used to separate methane from carbon dioxide, oxygen and nitrogen in the biogas stream by the difference of sizes of the molecules and physical forces.

It often uses activated carbon or zeolites as adsorption material, and operates at different pressure levels in four stages: adsorption, depressuring, regeneration and pressure build-up as is shown in the following figure:

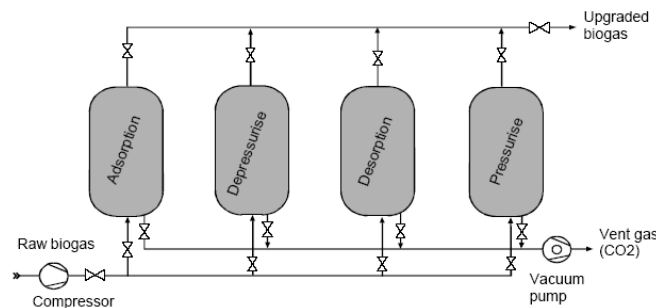

**Figure 1: Pressure Swing Adsorption<sup>3</sup>**

Raw biogas from the methane capture project is first separated from water and hydrogen sulphide, then passes to the compressed adsorption phase where the non-methane gases are adsorbed by the activated carbon or zeolites, after that the adsorption material is recovered in several low-pressure phases.

This technology delivers an upgraded gas with up to 97% of methane and meets the standards of natural gas distribution grid.

#### Absorption with water

This technology involves the use of water in a high pressure vessel to separate methane from other gases contained in biogas, such as carbon dioxide and hydrogen sulphide.

Raw biogas is mixed with water at high pressure in the absorption column, where non-methane gases and a small quantity of methane are absorbed by the water. The gas that leaves the column can contain up to 97% of methane, and water used in the process is often regenerated in a flash tank, where absorbed molecules are separated from the water (including small amounts of methane).

In some cases, water used in the process is not regenerated. When that happens, all the gases previously absorbed leave the upgrading facility dissolved in the water.

<sup>3</sup> Cited by Persson, Margareta (2003). Evaluation of Upgrading Techniques for Biogas. Malmö, Sweden: Swedish Gas Centre.

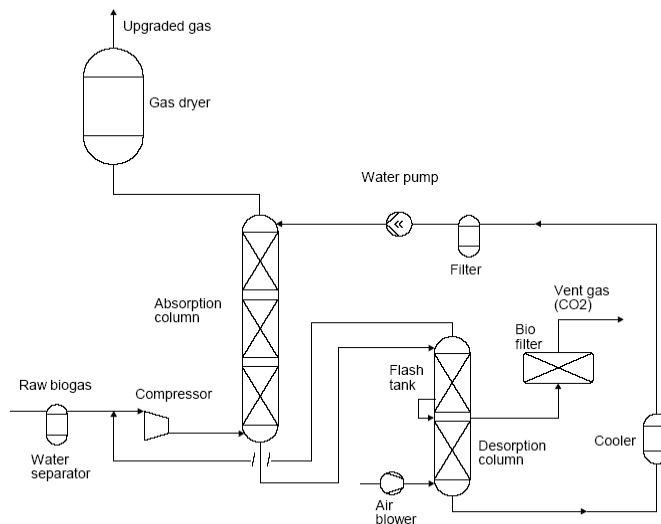

Figure 2: Absorption with water with recirculation<sup>4</sup>

-----

History of the document

| Version  | Date                               | Nature of revision(s)  |
|--|------------------------------------|--|
| 02   | EB 55, Annex #<br>30 July 2010     | <ul style="list-style-type: none"> <li>To clarify that the methodology can be used in conjunction with AM0025 and ACM0014; and</li> <li>Deletes the reference to the methodology AM0013 as this methodology has been withdrawn.</li> </ul> |
| 01.1   | EB 39, Paragraph 22<br>16 May 2008 | “Tool to calculate baseline, project and/or leakage emissions from electricity consumption” replaces the withdrawn “Tool to calculate project emissions from electricity consumption”.   |
| 01   | EB 32, Annex 1<br>22 June 2007     | Initial adoption.  |
| <b>Decision Class:</b> Regulatory<br><b>Document Type:</b> Standard<br><b>Business Function:</b> Methodology |                                    |  |

<sup>4</sup> Cited by Persson, Margareta (2003). Evaluation of Upgrading Techniques for Biogas. Malmö, Sweden: Swedish Gas Centre.