

**Revision to the approved baseline and monitoring methodology AM0001****“Incineration of HFC 23 waste streams”****I. SOURCE AND APPLICABILITY****Source**

This methodology is based on a proposal from the HFC Decomposition Project in Ulsan, Republic of Korea whose Baseline study, Monitoring and Verification Plan and Project Design Document were prepared by INEOS Fluor Japan Limited (Japan), Foosung Tech Corporation Co., Ltd. (Korea) and UPC Corporation Ltd. (Korea) (version 2.4, July 8, 2003). For more information regarding the proposal and its consideration by the Executive Board please refer to case NM0007: “HFC Decomposition Project in Ulsan” on

<http://cdm.unfccc.int/methodologies/PAmethodologies/approved.html>

Selected approach from paragraph 48 of the CDM modalities and procedures

“Existing actual or historical emissions, as applicable”

Applicability

This methodology is applicable under the following conditions:

- The project activity is the destruction of HFC 23 (CHF₃) waste streams from an existing HCFC22 production facility, ~~where the project activity occurs;~~
- The HCFC-22 production facility has an operating history of at least three years ~~of operating history~~ between beginning of the year 2000 and the end of the year 2004 and has been in operation from 2005 until the start of the project activity;
- The HFC-23 destruction occurs at the same industrial site where the HCFC-22 production occurs (i.e. no offsite transport occurs).

~~;-and
2.where no regulation requires the destruction of the total amount of HFC23 waste.~~

II. BASELINE METHODOLOGY**Project Activity**

Production of HCFC 22 generates the HFC 23. Some of the HFC 23 may be captured and sold, but the HFC 23 may also be released to the atmosphere. The project activity captures and decomposes the HFC 23 that would otherwise be released to the atmosphere (and any HCFC 22 present in this waste stream)¹.

¹ In the example of the Ulsan project activity proposal the destruction process will decompose the HFC 23 by heating it to more than 1,200°C in a thermal oxidation chamber with air and steam using LNG as a supplemental fuel. This yields CO₂, HCl and HF as by-products in a hot stream of offgas that also contains nitrogen, oxygen, carbon dioxide and moisture. This gas stream is cooled, the acids and moisture are absorbed in an aqueous solution and the acids in the solution are then neutralized with slaked lime to yield calcium chloride (CaCl₂) and



Emission Reduction

Waste HFC 23 is typically released into the atmosphere. Thus, **absent regulations to restrict HFC 23 emissions**, any HFC 23 not recovered for sale **and not destroyed to meet regulatory requirements** is assumed to be released to the atmosphere.

The greenhouse gas emission reduction achieved by the project activity is the quantity of waste HFC 23 actually destroyed less the greenhouse gas emissions generated by the destruction process less leakage due to the destruction process. Specifically, the greenhouse gas emission reduction (ER_y) achieved by the project activity during a given year (y) is equal to the quantity of HFC 23 waste from HCFC22 production facility (Q_HFC23_y) destroyed by the project activity less the baseline HFC 23 destruction (B_HFC23_y) during that year multiplied by the approved Global Warming Potential² value for HFC23 (GWP_HFC23) less the greenhouse gas emissions generated by the destruction process (E_DP_y) less greenhouse gas leakage (L_y) due to the destruction process.

$$ER_y = (Q_HFC23_y - B_HFC23_y) * GWP_HFC23 - E_DP_y - L_y \quad (1)$$

Where,

- ER_y is the greenhouse gas emission reduction measured in tonnes of CO₂ equivalents (tCO₂e),
- Q_HFC23_y is the quantity of waste HFC 23 destroyed during the year measured in metric tonnes,
- B_HFC23_y is the baseline quantity of HFC 23 destroyed during the year measured in metric tonnes.
- GWP_HFC23 is the Global Warming Potential that converts 1 tonne of HFC 23 to tonnes of CO₂ equivalents (tCO₂e/tHFC 23). The approved Global Warming Potential value for HFC 23 is 11,700 tonnes CO₂e/tonne HFC 23 **for the first commitment period under the Kyoto Protocol**.

The emissions due to the destruction process (E_DP_y) and leakage (L_y) are both measured in tonnes of CO₂ equivalent. The quantity of waste HFC 23 destroyed (Q_HFC23_y) is calculated as the product of the quantity of waste HFC 23 supplied to the destruction process (q_HFC23_y) measured in metric tonnes and the purity of the waste HFC 23 (P_HFC23_y) supplied to the destruction process expressed as the fraction of HFC 23 in the waste [$Q_HFC23_y = q_HFC23_y * P_HFC23_y$].

The destruction process uses fuel (e.g., natural gas), steam and/or electricity. The steam and electricity are assumed to be purchased, so the emissions associated with these energy sources are included in the leakage calculation.³ The emissions due to the destruction process (E_DP_y) are the emissions due to the **natural gas/fossil fuel** use, the emissions of HFC 23 not destroyed and the greenhouse gas emissions of the destruction process. Thus:

calcium fluoride (CaF₂). The CaCl₂ and CaF₂ are disposed in a landfill. The remaining cooled and neutralised gas (now nitrogen/oxygen/carbon dioxide with low levels of moisture) is vented to atmosphere.

² **For the first commitment period under the Kyoto Protocol**, Global Warming Potential values used shall be those provided by the Intergovernmental Panel on Climate Change in its Second Assessment Report (“1995 IPCC GWP values”).

³ If the steam and/or electricity was generated within the project boundary, the associated emissions would be included in the equation for the emissions due to the destruction process.



$$E_{DP_y} = ND_{HFC23_y} * GWP_{HFC23} + Q_{FF_y} * E_{FF_y} + Q_{HFC23_y} * EF \quad (2)$$

Where,

ND_{HFC23_y} is the quantity of HFC 23 not destroyed during the year,
 $Q_{NG_y-FF_y}$ is the quantity of fossil fuel natural gas used by the destruction process during the year measured in cubic metres or tons (m^3 or tons), and
 $E_{NG_y-FF_y}$ is the emissions coefficient factor for natural gas fossil fuel combustion measured in tonnes CO₂ equivalent per cubic metre unit of natural gas fossil fuel (t CO₂e/m³ or ton). If natural gas is used, the value of $E_{NG_y-FF_y}$ will vary by region and over time⁴, but is of the order of 0.00188 tCO₂e/m³.

If a different fuel, such as liquid petroleum gas (LPG), is used for the incineration process, the variables Q_{NG_y} and E_{NG_y} are replaced with variables for the quantity of fuel used and emissions coefficient for that fuel.

The quantity of HFC 23 not destroyed (ND_{HFC23_y}) is typically small⁵; the monitoring plan provides for its periodic on site measurement. Theoretically HFC 23 can also leak to the water effluent and then escape to the atmosphere. This possibility is ignored because it is infinitesimally small; the solubility of HFC 23 is 0.1% wt at 25°C water.

The thermal destruction process converts the carbon in the HFC 23 into CO₂, which is released to the atmosphere. The quantity of CO₂ produced by the destruction process is the product of the quantity of waste HFC 23 (Q_{HFC23_y}) destroyed and the emission factor (EF). The emission factor is calculated as follows:

$$EF = \frac{44}{\text{molecular weight of HFC 23} / \text{number of C in a molecule of HFC 23}} = \frac{44}{70/1} = 0.62857 \quad (3)$$

The thermal destruction process also produces a small quantity of N₂O emissions. The N₂O emissions, on a CO₂ equivalent basis, are a small fraction of the CO₂e emissions and are therefore ignored.

Baseline

The baseline quantity of HFC 23 destroyed is the quantity of the HFC 23 waste stream required to be destroyed by the applicable regulations. If the entire waste stream is destroyed, Q_{HFC23_y} is the total amount of HFC 23 waste generated and the quantity required to be destroyed by the applicable regulations is:

$$B_{HFC23_y} = Q_{HFC23_y} * r_y \quad (4)$$

⁴ In the example of the proposed Ulsan project activity it is of the order of 0.00188 tCO₂e/m³.

⁵ In the example of the proposed Ulsan project activity the quantity of HFC 23 not destroyed is estimated at 0.001% of the quantity of HFC 23 supplied to the destruction process.



Where:

r_y is the fraction of the waste stream required to be destroyed by the regulations that apply during year y . In the absence of regulations requiring the destruction of HFC 23 waste, the typical situation in non-Annex B Parties, $r_y = 0$. Absent regulations on HFC 23 emissions, the HFC 23 waste is typically released to the atmosphere so the baseline is zero destruction.

To exclude the possibility of manipulating the production process to increase the quantity of waste, the quantity of HFC 23 waste (Q_{HFC23_y}) is limited to a fraction (w) of a maximum quantity of actual HCFC22 production during the year at the originating plant that is eligible for crediting ($Q_{HCFC_{y,max}}$).

$$Q_{HFC23_y} \leq Q_{HCFC_{y,max}} * w \quad (5)$$

Where:

$Q_{HCFC_{y,max}}$ = Maximum annual production of HCFC-22 at the originating plant that is eligible for crediting (metric tonnes per year)

w = Waste generation rate (HFC 23⁶)/(HCFC 22) for the originating plant (metric tons of HFC23 per metric tons of HCFC22)

Q_{HCFC_y} is the actual production of HCFCs during the year at the plant where the HFC 23 waste originates measured in metric tonnes.

The maximum annual HCFC-22 production quantity that is eligible for crediting ($Q_{HCFC_{y,max}}$) is the lower value between

- the actual HCFC-22 production in year y (Q_{HCFC_y}); and
- the maximum historical annual HCFC-22 equivalent production level ($Q_{HCFC_{eHist}}$) at this plant (in tonnes of HCFC22) during any of the last three (3) years between beginning of the year 2000 and the end of the year 2004. $Q_{HCFC_{eHist}}$ includes the actual HCFC-22 production plus an HCFC-22 production equivalent to the CFC production at swing plants adjusted appropriately to account for the different production rates of HCFC22 and CFCs.

In case where two or more HCFC-22 production lines are operated at one industrial site, the limit to Q_{HCFC_y} should be applied to the total production at the industrial site and calculated for all production lines together. In this case, the historical annual production of the industrial site in a particular year corresponds to the sum of the production in all production lines at the industrial site during that year. $Q_{HCFC_{eHist}}$ then corresponds to the maximum of the annual production in all production lines ($Q_{HCFC_{eHist,x}}$).

The CFC production at swing plants should be included as an equivalent HCFC-22 production in $Q_{HCFC_{eHist}}$ only for those production lines:

[Option 1: that have produced HCFC-22 at any time between 1 January 2000 and 31 December 2004. This includes the CFC-11 and CFC-12 production in years where only CFCs and no HCFC-22 production occurred in that production line.]

⁶ The quantity of HFC 23 used to calculate this coefficient is the sum of HFC 23 recovered for sale plus the waste HFC 23.



[Option 2: and only for those years in which HCFC-22 was actually produced in that production line, i.e. the production of CFC-11 and CFC-12 should not be included for those years where no HCFC-22 production occurred in that production line.]

The production of CFC-11 and CFC-12 should be included in Q_{HCFC_v} in each relevant historical year x by adjusting the production of CFC-11 and CFC-12 to an equivalent HCFC-22 production level, as follows:

$$Q_{HCFCe_{Hist}} = MAX[Q_{HCFCe_{Hist,x}}] \quad (5a)$$

$$HCFCe_{Hist,x} = Q_{HCFC_{Hist,x}} + Q_{HCFC_{Hist,swing,x}} \quad (5b)$$

$$Q_{HCFC_{Hist,swing,x}} = \frac{C_{HCFC-22}}{C_{CFC}} \cdot Q_{CFC,Hist,x} \quad (5c)$$

Where:

- $Q_{HCFCe_{Hist,x}}$ = Actual HCFC-22 production during the year x (t HCFC-22 / yr)
- $Q_{HCFC_{Hist,swing,x}}$ = Production of CFC-11 and CFC-12 in the swing plant during the year x , adjusted to an equivalent level of HCFC-22 production (t HCFC-22e / yr)
- $C_{HCFC-22}$ = HCFC-22 production capacity of the facility (tons of HCFC-22 per hour)
- C_{CFC} = CFC production capacity of the facility (tons of CFC-11 and CFC-12 per hour)
- x = Any of the last three years between beginning of the year 2000 and the end of the year 2004
- $Q_{CFC,Hist,x}$ = Production of CFC-11 and CFC-12 in the swing plant during the year x (tons of CFC-11 and CFC-12 / yr)

The HCFC-22 and CFC production capacities of the facility ($C_{HCFC-22}$ and C_{CFC}) should be determined based on historical data from the period 2000 to 2004, by dividing the quantity of HCFC-22 or CFCs produced during a representative time period by that time period. The production capacities should be determined for all production lines separately. Furthermore, both production capacities (for HCFC-22 and the CFC production) should be determined for time periods where the production line was operating at the same load. Where such historic data is not available, project participants may undertake respective measurements of the HCFC-22 and CFC production capacity at the facility at full load operation. The ratio of $C_{HCFC-22} / C_{CFC}$ should not exceed the ratio of the molecular weight of HCFC-22 (86.47) to the molecular weight of the mixture of CFC-11 (137.38) and CFC-12 (120.91) produced in the production line.

The historical production data of HCFC-22 and, in case of swing plants, of CFC-11 and CFC-12 in each production line and the determination of the CFC and HCFC-22 production capacities (C_{CFC} and $C_{HCFC-22}$) and the maximum annual HCFC-22 production quantity that is eligible for crediting ($Q_{HCFC_{y,max}}$) should be documented transparently in the CDM-PDD.



The coefficient w is the waste generation rate (HFC 23⁷)/(HCFC 22) for the originating plant. The historical waste generation rate w shall be estimated for the three (3) most recent years of operation up to 2004. Direct measurement of HFC23 release is to be used where data are available, otherwise mass balance or other methods based on actual data⁸ are to be used. Uncertainty in emission rate estimates shall be quantified and conservative emission rate estimates shall be used when calculating expected emission reductions.

The value of w is set at the lowest of the three historical annual values estimated as specified above and is not to exceed 3% (0.03 tonnes of HFC 23 produced per tonne of HCFC 22 manufactured).

If insufficient data is available for the calculation of HFC23 release for all three (3) most recent years of operation up to 2004, then the default value for w to be used is 1.5%.

The measurement procedures, calculations and assumptions used to determine w should be documented transparently in the CDM-PDD.

Additionality

In the absence of regulations requiring HFC 23 destruction it is typically released to the atmosphere because a destruction facility entails significant capital and operating costs and the host entity has no direct economic incentive to incur these costs. If the quantity of HFC 23 destroyed is greater than the baseline quantity destroyed, the project activity is additional. The baseline quantity of HFC 23 destroyed is the quantity, if any, required to be destroyed by the host country's regulations governing the plant.

Leakage

Leakage is emissions of greenhouse gases due to the project activity that occur outside the project boundary. The sources of leakage due to the destruction process are:

- Greenhouse gas (CO₂ and N₂O) emissions associated with the production of purchased energy (steam and/or electricity)
- CO₂ emissions due to transport of sludge to the landfill

$$L_y = \sum_i (Q_{F_{i,y}} * E_{F_{i,y}}) + ET_y \quad (6)$$

Where $Q_{F_{i,y}}$ is the quantity of energy type F_i purchased for the destruction process during year y , $E_{F_{i,y}}$ is the greenhouse gas emissions factor for energy type F_i during year y , and ET_y and the greenhouse gas emissions associated with sludge transport during year y .

⁷ The quantity of HFC 23 used to calculate this coefficient is the sum of HFC 23 recovered for sale plus the waste HFC 23.

⁸ The estimation may be based on the carbon efficiency and the fluorine efficiency of the process and normally the average of the two values shall be used unless there are overriding considerations (such as a much lower uncertainty of one of the two evaluations) that can be adequately documented. If HCFC22 leakage was not directly measured, the carbon and fluorine efficiencies may be used to determine both HFC23 waste and HCFC22 leakage. The DOE shall verify if the estimates obtained in this way can reasonably be used to calculate w or if it shall be considered that insufficient data are available to calculate HFC23 release for this plant (and therefore require the use of a default value of 1.5%).



III. MONITORING METHODOLOGY

Monitoring methodology is based on direct measurement of the amount of HFC 23 waste destroyed and of the energy used by the destruction process as shown in Figure 1.

This monitoring methodology provides for direct and continuous measurement of the actual quantity HFC 23 destroyed, as well as the quantities of electricity, steam and fossil fuel used by the destruction process.

The emission reductions are dominated by the quantity of HFC 23 destroyed. To measure this quantity accurately two flow meters are used. The flow meters shall be calibrated every six months by an officially accredited entity. The zero check on the flow meters shall be conducted every week. If the zero check indicates that flow meter is not stable, and immediate calibration of the flow meter shall be undertaken. Most of the time, under normal operation, both flow meters measure the same amount of HFC 23 flows simultaneously. Where the flow meter readings differ by greater than twice their claimed accuracy (for example 10% if the accuracy is claimed to be $\pm 5\%$) then the reason for the discrepancy is investigated and the fault remedied. For the sake of conservativeness the lower value of the two readings will always be used to estimate the HFC 23 waste flows. The monthly quantity of HFC 23 waste flows (q_{HFC23_m}) is the sum of the lower periodic⁹ reading of the two meters, as follows:

$$q_{\text{HFC23}_m} = \sum_{t=\text{number of period in a month}} \min^m(q_{\text{HFC23}_{1,t}}, q_{\text{HFC23}_{2,t}})$$

Other factors in the monitoring process for quality control are:

- Purity of HFC 23 is checked monthly by sampling using gas chromatography. Combinations of continuous flow measurement and calculation will be used to estimate quantities of other materials, e.g., air that may be in the HFCs if this is appropriate.
- In case where the HFC-23 from several production lines is destroyed in one HFC-23 destruction facility or in cases where HFC-23 is captured and sold or in cases where not all of the HFC-23 generation is destroyed, the amount of HFC 23 waste generated at the HCFC-22 production plant should be measured with a single flow meter for each production line, in addition to the measurement of the amount of HFC-23 destroyed. For transparency purposes, this waste generation ~~The output of HFC 23 from the HCFC 22 plant~~ will be checked yearly by comparing it with the amount of ~~HCFC 22 produced to the sum of the~~ HFC 23 recovered for sale and the HFC 23 decomposed.

The quantities of gaseous effluents (CO, HCl, HF, Cl₂, dioxin and NOX) and liquid effluents (PH, COD, BOD, n-H (normal hexane extracts), SS (suspended solid), phenol, and metals (Cu, Zn, Mn and Cr) are measured every six months to ensure compliance with environmental regulations.

⁹ the periodic frequency of less than one hour can be used, as documented in the PDD.

Figure 1
Monitoring approach

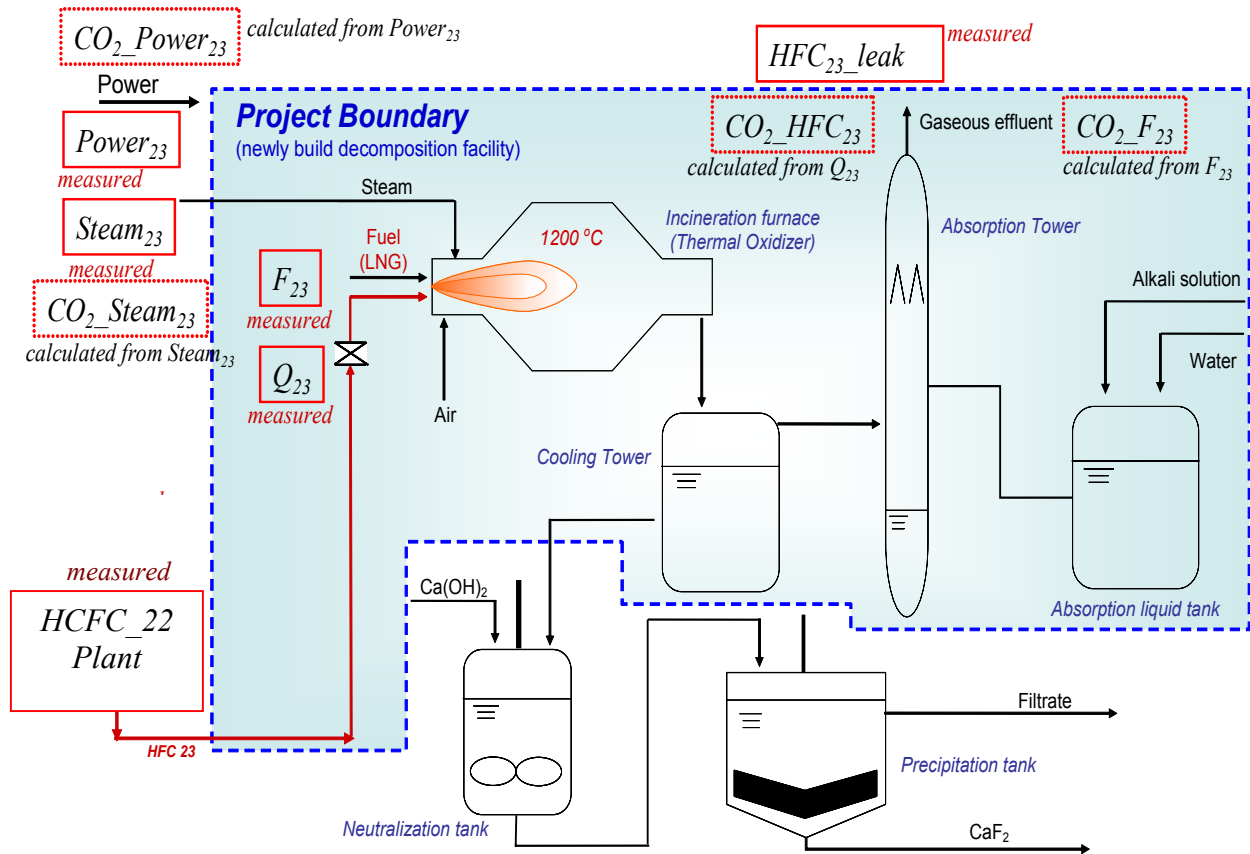

$$CO_2_Power_{23} = E_F_{1,y}$$

$$Power_{23} = Q_F_{1,y}$$

$$Steam_{23} = Q_F_{2,y}$$

$$CO_2_Steam_{23} = E_F_{2,y}$$

$$HCFC_{22} \text{ Plant} = Q_HCFC_y$$

$$F_{23} = Q_NG_y$$

$$CO_2_F_{23} = Q_NG_y * E_NG_y$$

$$Q_{23} = Q_HFC_{23,y}$$

$$HFC_{23_leak} = ND_HFC_{23,y}$$

$$CO_2_HFC_{23} = Q_HFC_{23,y} * EF$$



Data to be collected or used to monitor emissions from the project activity, and how this data will be archived

Monitored data for project emissions in the boundary (GHG)

ID number	Data type	Data variable	Data unit	Measured (m), calculated (c) or estimated (e)	Recording frequency	Proportion of data to be monitored	How will the data be archived? (electronic/paper)	For how long is archived data kept?	Comment
1. q_HFC23y	Mass	Quantity of HFC 23 supplied to the destruction process	kg-HFC 23	(m) measured by flow meters in parallel that are calibrated weekly	Monthly	100%	Electronic	Project lifetime	The monthly quantity of HFC 23 waste flows (q_HFC23 _m) is the sum of the lower periodic ¹⁰ reading of the two meters.
1b.	Mass	Quantity of HFC 23 generated in each HCFC-22 production line	kg HFC 23	measured by a single flow meter	Monthly	100%	Electronic		Applicable where (a) not all HFC-23 is destroyed or (b) several production lines operate or (c) part of the HFC-23 is sold.
2. HFC23y	%	Purity of the HFC 23 supplied to the destruction process	%	(m) measured monthly by sampling	Monthly		Electronic	Project lifetime	Measured using gas chromatography
3. Q_NGyFFy	Mass	Quantity of natural gas fossil fuel used by the destruction process	m ³	(m) measured	Monthly	100%	Electronic	Project lifetime	Measured using a fuel meter

¹⁰ the periodic frequency of less than one hour can be used, as documented in the CDM-PDD.



In addition the quantities of gaseous effluents (CO, HCl, HF, Cl₂, dioxin and NO_X) and liquid effluents (PH, COD, BOD, n-H (normal hexane extracts), SS (suspended solid), phenol, and metals (Cu, Zn, Mn and Cr) are measured in a manner and with a frequency that complies with local environmental regulations.



D.4. 1 Potential sources of emissions which are significant and reasonably attributable to the project activity, but which are not included in the project boundary, and identification if and how data will be collected and archived on these emission sources.

Monitored data for project emissions outside of the boundary (GHG)

ID number	Data type	Data variable	Data unit	Measured (m), calculated (c) or estimated (e)	Recording frequency	Proportion of data to be monitored	How will the data be archived? (electronic/paper)	For how long is archived data kept?	Comment
4. ND_HFC23y	Mass	Quantity of HFC 23 in gaseous effluent	kg-HFC	(m) measured	Monthly	100%	Electronic	Project lifetime	When the thermal oxidizer stops, analysis of the effluent gas is done to check leaked HFC 23 by sampling.
5. Q_F1,y,y	Energy	Electricity consumption by the destruction process	kWh	(m) measured	Monthly	100%	Electronic	Project lifetime	Metered
6. Q_F2,y,y	Energy	Steam consumption by the destruction process	kg-steam	(m) measured	Monthly	100%	Electronic	Project lifetime	Metered



D.5. Relevant data necessary for determining the baseline of anthropogenic emissions by sources of GHG and identification if and how such data will be collected and archived.

Monitored data for baseline emissions (GHG)

ID number	Data type	Data variable	Data unit	Measured (m), calculated (c) or estimated (e)	Recording frequency	Proportion of data to be monitored	How will the data be archived? (electronic/paper)	For how long is archived data kept?	Comment
7. Q_HCFC _y	Mass	The quantity of HCFC 22 produced in the plant generating the HFC 23 waste	tonnes - HCFC 22	(m) measured	Monthly	100%	Electronic	Project lifetime	Reference data to check cut off condition and rough estimation of Q_HCFC23 _y . If more than one production lines exist in an industrial site production of each shall be separately measured and reported.
8. HFC23_sold	Mass	HFC 23 sold by the facility generating the HFC 23 waste	tonnes -HFC 23	(m) measured	Annually	100%	Electronic	Project lifetime	Reference data to check cut off condition and rough estimation of Q_HCFC23 _y
Q_HCFC _{Hist}	Mass	The quantity of HCFC 22 produced in the plant generating the HFC 23 waste	tonnes - HCFC 22	(m)	annually	100%	Electronic	Project lifetime	based on the historical production records HCFC production for the years between beginning of the year 2000 and the end of the year 2004. This



									data shall be reported in the registered CDM-PDD.
C _{HCFC-22}	Mass	Hourly production HCFC 22 capacity of production line	tonnes - HCFC 22/ hour	(m)		100%	Electronic	Project lifetime	This data is used to estimate equivalence of HCFC and CFC production. This value is either based on historical records between beginning of 2000 and end of 2004 or measurements. Both should be at the same load levels as the corresponding data on CFC production rate.
C _{CFC}	Mass	Hourly CFC production capacity of production line	tonnes -CFC/ hour	(m)		100%	Electronic	Project lifetime	This data is used to estimate equivalence of HCFC and CFC production. This value is either based on historical records between beginning of 2000 and end of 2004 or measurements. Both should be at the same load levels as the corresponding data on HCFC 22 production rate.



Q _{HCFC_{Hist,sw}} ing	Mass	HCFC22 equivalent of historic CFC production.	tonnes - HCFC 22/ hour	(c)		100%	Electronic	Project lifetime	Data for all years between beginning of 2000 and end of 2004 shall be reported in the registered CDM PDD.
Q _{HCFC_{eHist,s}} wing	Mass	Historical HCFC22 production.	tonnes - HCFC 22/ hour	(c)		100%	Electronic	Project lifetime	Data for all years between beginning of 2000 and end of 2004 shall be reported in the registered CDM PDD.
w	ratio	Production of HFC23 per tonne of HCFC22	fraction	e		100%	Electronic	Project lifetime	w shall be estimated either using data for years between beginning of 2000 and end of 2004 or if no data is available as per procedure defined in the baseline methodology. The data shall be reported in the registered CDM PDD along with details of measurement procedures, calculations and assumptions.



**D.6. Quality control (QC) and quality assurance (QA) procedures are being undertaken for data monitored.
(data items in tables contained in section D.3., D.4. and D.5 above, as applicable)**

Data	Uncertainty level of data (High/Medium/Low)	Are QA/QC procedures planned for these data?	Outline explanation why QA/QC procedures are or are not being planned.
1. q_HFC23y	Low	Yes. A QA & QC organization will be formed and QA & QC procedures that are equivalent to JIS (Japanese Industrial Standard) in terms of equipment and analytical method will be set. Will be measured using two flowmeters in parallel. The flow meters shall be calibrated every six months by an officially accredited entity. The zero check on the flow meters shall be conducted every week. If the zero check indicates that flow meter is not stable, and immediate calibration of the flow meter shall be undertaken.	QA & QC procedures are set and implemented in order to, 1. Secure a good consistency through planning to implementation of this CDM project and, 2. Stipulate who has responsibility for what and, 3. Avoid any misunderstanding between people and organization involved.
1b.	Low	Check for consistency by determining the HFC23/HCFC-22 waste generation rate and comparing it with the waste generation in previous years.	
2. P_HFC23y	Low	Will be measured using gas chromatography	Ditto
3. Q_NGyFFy	Low	Will be metered using natural gas meter	Ditto
4. ND_HFC23y	Low	Will be measured from the gas effluent of the destruction process	Ditto
5. Q_F1y	Low	Will be metered using electricity meter	Ditto
6. Q_F2y	Low	Will be metered using steam meter	Ditto
7. Q_HCFCy		Will be obtained from production records of the facility where the HFC 23 waste originates	Ditto
8. HFC23_sold		Will be obtained from production and sales records of the facility where the HFC 23 waste originates	Ditto



All of the measurement instruments are to be recalibrated monthly per internationally accepted procedures except for the HFC 23 flowmeters whose recalibration frequency is weekly to reduce the error level.



Miscellaneous parameters

Calculation of the emission reductions also requires data for:

$E_{NG_y-FF_y}$ - The emissions coefficient for the ~~natural gas~~ fossil fuel used by the destruction process in tonnes of CO₂ equivalent per cubic metre ~~or ton~~ of ~~natural gas~~ fossil fuel (t CO₂e/m³ ~~or ton~~). The value of $E_{NG_y-FF_y}$ will vary by region and over time.

$E_{F_{i,y}}$ - The emissions coefficient for the electricity used by the destruction process in tonnes of CO₂ equivalent per kWh. The value of $E_{F_{i,y}}$ for electricity depends on the source of the electricity and may vary over time.

$E_{F_{i,y}}$ - The emissions coefficient for the steam used by the destruction process in tonnes of CO₂ equivalent per tonne steam. The value of $E_{F_{i,y}}$ for steam depends on the source of the steam and may vary over time.

GWP_HFC23 - The 100 year Global Warming Potential of HFC 23. The Global Warming Potential converts 1 tonne of HFC 23 to tonnes of CO₂ equivalents (tonnes CO₂e/tonnes HFC 23). The approved Global Warming Potential value for HFC 23 for the first commitment period is 11,700 tonnes CO₂e/tonne HFC 23.