

Draft consolidated baseline and monitoring methodology ACM00XX**“Consolidated methodology for electricity and heat generation from biomass residues”****I. SOURCE AND APPLICABILITY****Sources**

This consolidated baseline and methodology is based on elements from the following approved consolidated baseline and monitoring methodology:

- ACM0006 “Consolidated methodology for electricity generation from biomass residues”.

This methodology also refers to the latest approved versions of the following tools:

- “Tool to calculate the emission factor for an electricity system”;
- “Tool to determine methane emissions avoided from disposal of waste at a solid waste disposal site”;
- “Tool to calculate project or leakage CO₂ emissions from fossil fuel combustion”;
- “Tool to calculate baseline, project and/or leakage emissions from electricity consumption”.

For more information regarding the proposals and the tools as well as their consideration by the Executive Board please refer to <<http://cdm.unfccc.int/goto/MPappmeth>>.

Selected approach from paragraph 48 of the CDM modalities and procedures

“Existing actual or historical emissions, as applicable”.

and/or

“Emissions from a technology that represents an economically attractive course of action, taking into account barriers to investment”.

Definitions

For the purpose of this methodology, the following definitions apply:

Biomass. *Biomass* is non-fossilized and biodegradable organic material originating from plants, animals and microorganisms. This shall include products, by-products, residues and waste from agriculture, forestry and related industries as well as the non-fossilized and biodegradable organic fractions of industrial and municipal wastes. Biomass also includes gases and liquids recovered from the decomposition of non-fossilized and biodegradable organic material.

Biomass residues. *Biomass residues* are defined as biomass that is a by-product, residue or waste stream from agriculture, forestry and related industries. This shall not include municipal waste or other wastes that contain fossilized and/or non-biodegradable material (however, small fractions of inert inorganic material like soil or sands may be included).

Heat. *Heat* is defined as useful thermal energy that is generated in a heat generation plant (e.g. a boiler, a cogeneration plant, thermal solar panels, etc.) and transferred to a heat carrier (e.g. hot liquids, hot gases, steam, etc.) for utilization in thermal applications and processes, including power generation. For the purposes of this methodology, heat does not include waste heat, i.e. heat that is transferred to the environment without utilization, for example, heat in flue gas, heat transferred to cooling towers or any other heat losses. Note that heat refers to the *net* quantity of thermal energy that is transferred to a heat carrier at the heat generation facility. For example, in case of a boiler it refers to the difference of the enthalpy of the steam generated in the boiler and the enthalpy of the feed water and, if applicable, any condensate return.

Process heat. Process heat is defined as heat that is not used for mechanical or electric power generation by end-users.

Heat generator / heat generation equipment. Heat generator or heat generation equipment is defined as a facility that generates thermal energy by combustion of fuels. This includes, for example, a boiler that supplies steam or hot water, a heater that supplies hot oil or thermo fluid, or a furnace that supplies hot gas or combustion gases. When several pieces of heat generation equipment are included in one project activity, each heat generation equipment is referred to as “unit”.

Power. *Power* refers to electric power. Mechanical and other forms of power are not included under this methodology.

Power plant. A power plant is an installation that generates electric power through the conversion of heat to mechanical power using a heat engine. The heat is produced in a heat generator, through the combustion of fuels, and the electric power is generated in an electricity generator, coupled to the heat engine. The power plant includes all the equipment necessary to generate electric power, including, *inter alia*, heat generators, heat engines, electricity generators, gear boxes and speed reducers, instrumentation and control equipment, cooling equipment, pumps, fans, and also the systems required for the preparation, storage and transportation of fuels. A common example of power plant is a steam cycle plant, in which heat is produced in boilers through the combustion of fuels, transferred to steam which then drives steam turbines. The steam turbines are coupled, normally via speed reducers, to electricity generators which in turn finally generate the electric power. The steam leaving the turbines is directed to condensers, so that its residual heat content is transferred to the atmosphere via a cooling towers system. In the case of several heat generators providing heat to one heat header and/or several heat engines receiving heat from one heat header, all equipment connected to the heat header should be considered as part of the power plant.

Power-only plant. A power-only plant is a power plant to which the following conditions apply:

- (a) All heat engines of the power plant produce only power and do not co-generate heat; and
- (b) The thermal energy (e.g. steam) produced in equipment of the power plant (e.g. a boiler) is only used in heat engines (e.g. turbines or motors) and not for other processes (e.g. heating purposes or as feedstock in processes). For example, in the case of a power plant with a steam header, this means that *all* steam supplied to the steam header must be used in turbines.

Power-and-heat plant. A power-and-heat plant is a power plant which does not fulfill the conditions of a power-only plant. Power-and-heat plants encompass thus two broad categories of power plants: cogeneration plants (as defined below) and plants in which heat and power are produced at the same

installation although not necessarily in cogeneration mode, e.g. heat is extracted directly from a common heat header that also supplies heat to heat engines for power generation.

Cogeneration. A cogeneration plant is a power-and-heat plant in which at least one heat engine simultaneously generates both heat and power.

Net quantity of electricity generation. The *net quantity of electricity generation* is the electricity generated by the power plant unit after exclusion of parasitic and auxiliary loads, i.e. the electricity consumed by the auxiliary equipment of the power plant unit (e.g. pumps, fans, flue gas treatment, control equipment, etc) and equipment related to fuel handling and preparation.

Heat-to-power ratio. The heat to power ratio is defined as the quantity of process heat recovered from a heat engine per unit of electricity generated in the same heat engine, measured in the same energy units. For example, a heat engine producing 1 MWh_{el} of electricity and 2 MWh_{th} of process heat has a heat-to-power ratio of 2.

Applicability

This methodology is applicable to project activities that operate biomass-residue (co-)fired power-and-heat plants. The project activity may include the following activities or, where applicable, combinations of these activities:

- The installation of new plants at a site where currently no power and heat generation occurs (greenfield projects);
- The installation of new plants at a site where currently power or heat generation occurs. The new plant replaces or is operated next to existing plants (capacity expansion projects);
- The improvement of energy efficiency of existing plants (energy efficiency improvement projects), which can also lead to a capacity expansion, e.g. by retrofitting the existing plant;
- The total or partial replacement of fossil fuels by biomass residues in existing plants or in new plants that would have been built in the absence of the project (fuel switch projects), e.g. by increasing the share of biomass residues use as compared to the baseline, by retrofitting an existing plant to use biomass residues, etc.

The methodology is applicable under the following conditions:

- (1) No biomass types other than biomass residues are used in the project plant;¹
- (2) Fossil fuels may be co-fired in the project plant. However, the amount of fossil fuels co-fired shall not exceed 50% of the total fuel fired on an energy basis;
- (3) For projects that use biomass residues from a production process (e.g. production of sugar or wood panel boards), the implementation of the project shall not result in an increase of the processing capacity of raw input (e.g. sugar, rice, logs, etc.) or in other substantial changes (e.g. product change) in this process;

¹ Refuse Derived Fuel (RDF) may be used in the project plant but all carbon in the fuel, including carbon from biogenic sources, shall be considered as fossil fuel.

- (4) The biomass residues used by the project facility should not be stored for more than one year;
- (5) No significant energy quantities, except from transportation or mechanical treatment of the biomass residues, are required to prepare the biomass residues for fuel combustion, i.e. projects that process the biomass residues prior to combustion (e.g. esterification of waste oils, gasification, etc.) are not eligible under this methodology;
- (6) In the case of fuel switch project activities, the use of biomass residues or the increase in the use of biomass residues as compared to the baseline scenario is technically not possible at the project site without a capital investment in:
 - The retrofit or replacement of existing heat generators/boilers; or
 - The installation of new heat generators/boilers; or
 - A new dedicated biomass residues supply chain established for the purpose of the project (e.g. collecting and cleaning contaminated new sources of biomass residues that could otherwise not be used for energy purposes);
 - Equipment for preparation and feeding of biomass residues.

Finally, the methodology is only applicable if the most plausible baseline scenario, as identified per the “Procedure for the selection of the baseline scenario and demonstration of additionality” section hereunder, is:

- For power generation: scenarios P2 to P7, or a combination of any of those scenarios;
- For heat generation: scenarios H2 to H6;
- For biomass use: scenarios B1 to B8, or any combination of those scenarios. For scenarios B5 to B8, leakage emissions should be accounted for as per the procedures of the methodology.

II. BASELINE METHODOLOGY

Project boundary

The spatial extent of the project boundary encompasses:

- All plants generating power and/or heat located at the project site, whether fired with biomass residues, fossil fuels or a combination of both;
- All power plants connected physically to the electricity system (grid) that the project plant is connected to;
- All off-site heat sources that supply heat to the site where the project activity is located;
- The means of transportation of biomass residues to the project site;
- The site where the biomass residues would have been left for decay or dumped;
- The wastewater treatment facilities used to treat the wastewater produced from the treatment of biomass residues.

Explain in the CDM-PDD the specific situation of the project activity. For this purpose, project participants should document in the CDM-PDD:

- For each plant generating power and/or heat that has been operated at the project site within the most recent three years prior to the start of the project activity: the type and capacity of the heat

generators, the types and quantities of fuels which have been used in the heat generators, the type and capacity of heat engines, and whether the equipment continues operation after the start of the project activity;

- For each plant generating power and/or heat installed under the project activity: the type and capacity of the heat generators, the types and quantities of fuels used in the heat generators, the type and capacity of heat engines and direct heat extractions;
- For each plant generating power and/or heat that would be installed in the absence of the project activity: the type and capacity of the plant, including the type and capacity of the heat generators, heat engines and electric power generators used and the types and quantities of fuels which would be used in each heat generator.
- The average amounts of electricity and heat import from off-site sources that would happen in the absence of the project activity and the forecast for the project scenario.

Table 1 illustrates which emissions sources are included and which are excluded from the project boundary for determination of both baseline and project emissions. A schematic diagram of the project activity and the baseline scenario is presented in Figure 1.

Table 1: Emissions sources included or excluded from the project boundary

	Source	Gas		Justification / Explanation
Baseline	Electricity and heat generation	CO ₂	Included	Main emission source
		CH ₄	Excluded	Excluded for simplification. This is conservative.
		N ₂ O	Excluded	Excluded for simplification. This is conservative.
	Uncontrolled burning or decay of surplus biomass residues	CO ₂	Excluded	It is assumed that CO ₂ emissions from surplus biomass residues do not lead to changes of carbon pools in the LULUCF sector.
		CH ₄	To be decided by project participants	Project participants may decide to include this emission source, where case B1, B2 or B3 has been identified as the most likely baseline scenario.
		N ₂ O	Excluded	Excluded for simplification. This is conservative. Note also that emissions from natural decay of biomass are not included in GHG inventories as anthropogenic sources.
Project Activity	On-site fossil fuel consumption	CO ₂	Included	May be an important emission source
		CH ₄	Excluded	Excluded for simplification. This emission source is assumed to be very small.
		N ₂ O	Excluded	Excluded for simplification. This emission source is assumed to be very small.
	Off-site transportation of biomass residues	CO ₂	Included	May be an important emission source
		CH ₄	Excluded	Excluded for simplification. This emission source is assumed to be very small.
		N ₂ O	Excluded	Excluded for simplification. This emission source is assumed to be very small.
	Combustion of biomass	CO ₂	Excluded	It is assumed that CO ₂ emissions from surplus biomass do not lead to changes of carbon pools in the LULUCF sector.

residues for electricity and heat	CH ₄	Included or excluded	This emission source must be included if CH ₄ emissions from uncontrolled burning or decay of biomass residues in the baseline scenario are included.
	N ₂ O	Excluded	Excluded for simplification. This emission source is assumed to be small.
Storage of biomass residues	CO ₂	Excluded	It is assumed that CO ₂ emissions from surplus biomass residues do not lead to changes of carbon pools in the LULUCF sector.
	CH ₄	Excluded	Excluded for simplification. Since biomass residues are stored for not longer than one year, this emission source is assumed to be small.
	N ₂ O	Excluded	Excluded for simplification. This emissions source is assumed to be very small.
Wastewater from the treatment of biomass residues	CO ₂	Excluded	It is assumed that CO ₂ emissions from surplus biomass residues do not lead to changes of carbon pools in the LULUCF sector.
	CH ₄	Included	This emission source shall be included in cases where the waste water is treated (partly) under anaerobic conditions.
	N ₂ O	Excluded	Excluded for simplification. This emission source is assumed to be small.

Figure 1 - Schematic diagram of the project activity and the baseline scenario

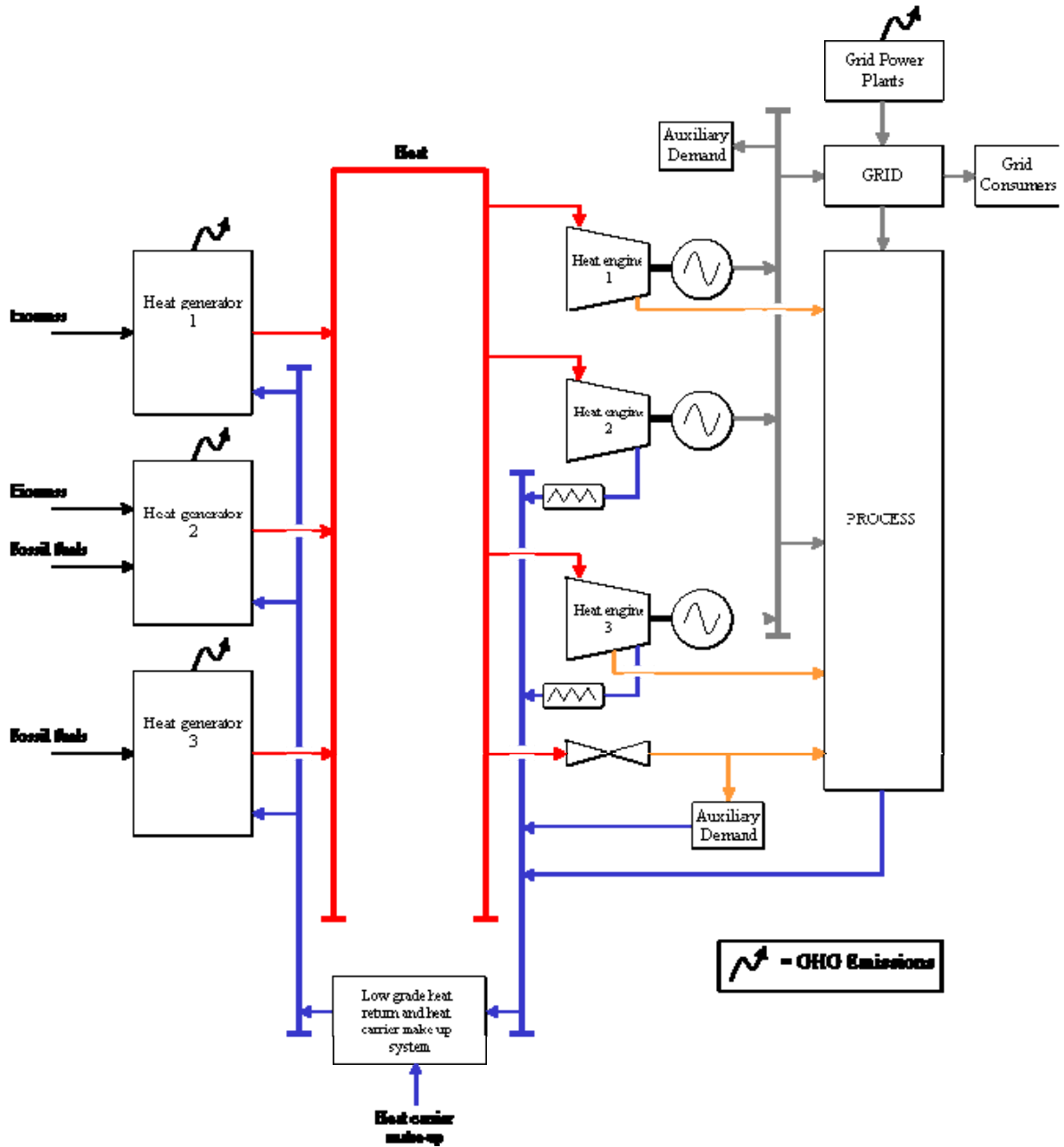

Procedure for the selection of the baseline scenario and demonstration of additionality

The selection of the baseline scenario and demonstration of additionality should be conducted by applying the following steps:

Step 1: Identification of alternative scenarios

This step serves to identify all alternative scenarios to the proposed CDM project activity(s) that can be the baseline scenario through the following sub-steps:

Step 1a: Define alternative scenarios to the proposed CDM project activity

Identify realistic alternative scenarios that are available to the project participants and that provide outputs or services with comparable quality, properties and application areas as the proposed CDM project activity.

In doing so, alternative scenarios should specify:

- How electric power would be generated in the absence of the CDM project activity; and
- How heat would be generated in the absence of the CDM project activity; and
- What would happen to the biomass residues in the absence of the project activity.

The alternative scenarios for electric power should include, *inter alia*:

- P1 The proposed project activity not undertaken as a CDM project activity;
- P2 If applicable², the continuation of power generation in existing power plants at the project site. The existing plants would operate at the same conditions (e.g. installed capacities, average load factors, or average energy efficiencies, fuel mixes, and equipment configuration) as those observed in the most recent three years prior to the project activity;
- P3 If applicable², the continuation of power generation in existing power plants at the project site. The existing plants would operate with different conditions from those observed in the most recent three years prior to the project activity;
- P4 If applicable², the retrofitting of existing power plants at the project site. The retrofitting may or may not include a change in fuel mix;
- P5 The installation of new power plants at the project site different from those installed under the project activity;
- P6 The production of power in specific off-site plants, excluding the power grid;
- P7 The production of power in the power grid.

The alternative scenarios for heat should include, *inter alia*:

- H1 The proposed project activity not undertaken as a CDM project activity;
- H2 If applicable², the continuation of heat generation in existing plants at the project site. The existing plants would operate at the same conditions (e.g. installed capacities, average load factors, or average energy efficiencies, fuel mixes, and equipment configuration) as those observed in the most recent three years prior to the project activity;

² This alternative is only applicable if there are existing plants operating at the project site.

- H3 If applicable², the continuation of heat generation in existing plants at the project site. The existing plants would operate with different conditions from those observed in the most recent three years prior to the project activity;
- H4 If applicable², the retrofitting of existing plants at the project site. The retrofitting may or may not include a change in fuel mix;
- H5 The installation of new plants at the project site different from those installed under the project activity;
- H6 The production of heat in specific off-site plants, excluding district heating;
- H7 The production of heat from district heating.

When defining plausible and credible alternative scenarios for power and heat generation, the guidance below should be followed:

- For any of the alternative scenarios described above, all assumptions with respect to installed capacities, load factors, energy efficiencies, fuel mixes, and equipment configuration, should be clearly described and justified in the CDM-PDD. The justification for existing plants should be based on the existing conditions of the plants and the justification for new plants, or changes to existing plants, should be based on design parameters selected considering realistic and credible alternative design options;
- The whole electricity and heat generation under the project scenario must be considered in the selection of the baseline scenario. Therefore, the capacities of heat and electricity generation, including the grid if applicable, considered in the baseline scenario should be able to deliver the same level of heat and power generation as that of the project scenario.
- If the project activity involves an increase in installed capacity, an increase in generation, and/or a change in demand of electricity or heat as compared to the historical situation, the baseline scenario should be determined for the overall generation under the project activity, possibly including a combination of the different scenarios described above. This is particularly relevant for cases in which existing plants have operated at the project site prior to the implementation of the project activity;
- In cases where alternative scenarios include the installation of new power or heat generation capacity at the project site other than the proposed project activity, the economically most attractive technology and fuel mix should be identified among those which provide the same service (i.e. the same power and, if applicable, heat quantity), that are technologically available and that are in compliance with relevant regulations. The type of technology, the efficiency of the plants and the fuel type should be selected in a conservative manner, i.e. where several technologies and/or fuel types could be used and are similarly economically attractive, the least carbon intensive fuel type/the most efficient technology should be considered. Ensure that the selected technology represents at least the common practice for new plants in the respective industry sector, in the country or region, excluding CDM registered projects;³
- If existing plants operated at the project site prior to the implementation of the project activity, they could be retired at the start of the project activity because they are replaced by the project plant, or they may initially be operated in parallel to the project plant and be retired at a future point in time (at the end of its lifetime). In such cases, the remaining lifetime of the existing equipment has to be determined and a baseline based on historical performance only applies until the existing power plant would have been replaced or retrofitted in the absence of the project

³ In case all similar plants are registered as CDM project activities, this assessment of common practice is not required.

activity. From that point of time, a different baseline shall apply. For the purpose of determining the remaining lifetime of equipment use the latest version of the “Tool to determine the remaining lifetime of equipment”. The remaining lifetime should be chosen in conservative manner, i.e. the earliest point in time should be chosen in cases where only a time frame can be estimated, and should be documented and justified in the CDM-PDD;

For the use of biomass residues, the alternative scenarios should include, *inter alia*:

- B1 The biomass residues are dumped or left to decay mainly under aerobic conditions. This applies, for example, to dumping and decay of biomass residues on fields;
- B2 The biomass residues are dumped or left to decay under clearly anaerobic conditions. This applies, for example, to landfills which are deeper than 5 meters. This does not apply to biomass residues that are stock-piled⁴ or left to decay on fields;
- B3 The biomass residues are burnt in an uncontrolled manner without utilizing it for energy purposes;
- B4 The biomass residues are used for power or heat generation at the project site in new and/or existing plants;
- B5 The biomass residues are used for power or heat generation at other sites in new and/or existing plants;
- B6 The biomass residues are used for other energy purposes, such as the generation of biofuels;
- B7 The biomass residues are used for non-energy purposes, e.g. as fertilizer or as feedstock in processes (e.g. in the pulp and paper industry);
- B8 The primary source of the biomass residues and/or their fate in the absence of the project activity cannot be clearly identified.⁵

When defining plausible and credible alternative scenarios for the use of biomass residues, the guidance below should be followed:

- The baseline scenario for the use of biomass residues should be separately identified for different categories of biomass residues, covering the whole amount of biomass residues supposed to be used in the project activity along the crediting period, and consistent with the alternative scenarios selected for power and heat generation (scenarios P and H above);
- A category of biomass residues is defined by three attributes: (1) its type (i.e. bagasse, rice husks, empty fruit bunches, etc.); (2) its source (e.g. produced on-site, obtained from an identified biomass residues producer, obtained from a biomass residues market, etc.); and (3) its fate in the absence of the project activity (Scenarios B above);
- For example, consider a project activity which includes the installation of a new biomass-only power plant, and the retrofit of an existing co-fired biomass-fossil-fuel power plant, which has historically used rice husks, produced on-site. Suppose that the project activity will use two types of biomass residues, rice husks (historical use plus an additional amount) and diverse agricultural residues (as additional biomass residues compared to the historical situation). Further consider that the rice husks used in the project would come from two different sources, on-site production and off-site supply from an identified rice mill. Presumably, the rice husks produced on-site would have been partly used on-site for electricity generation and partly be dumped in the

⁴ Further work is undertaken to investigate to which extent and in which cases methane emissions may occur from stock-piling biomass residues. Subject to further insights on this issue, the methodology may be revised.

⁵ For example, this scenario can be used if biomass residues are purchased from a market, or biomass residues retailers.

baseline. The rice husks procured off-site would have been dumped in the baseline. The diverse agricultural residues are purchased from a biomass retailer. For this example, four categories of biomass residues should be considered in the subsequent analysis, as illustrated in Table 2;

- Explain and document transparently in the CDM-PDD, using a table similar to Table 2, which quantities of which biomass residues categories are used in which installation(s) under the project activity and what is their baseline scenario. The last column of Table 2 corresponds to the quantity of each category of biomass residues (tonnes). For the selection of the baseline scenario and demonstration of additionality, at the validation stage, an *ex ante* estimation of these quantities should be provided. These quantities should be updated every year of the crediting period as part of the monitoring plan so as to reflect the actual use of biomass residues in the project scenario. These updated values should be used for emissions reductions calculations. Along the crediting period, new categories of biomass residues (i.e. new types, new sources, with different fate) can be used in the project activity. In this case, a new line should be added to the table.

Table 2: Example of a table for biomass residues categories

Biomass residues category (<i>k</i>)	Biomass residues type	Biomass residues source	Biomass residues fate in the absence of the project activity	Biomass residues use in project scenario	Biomass residues quantity (tonnes)
1	Rice husks	On-site production	Electricity generation on-site (B4)	Electricity generation on-site (biomass-only boiler)	See comments above
2	Rice husks	On-site production	Dumped (B1)	Electricity generation on-site (biomass-only boiler)	See comments above
3	Rice husks	Off-site from an identified rice mill	Dumped (B1)	Electricity generation on-site (biomass-only boiler)	See comments above
4	Agricultural residues	Off-site from a biomass residues retailer	Unidentified (B8)	Electricity generation on-site (co-fired boiler)	See comments above

- For biomass residues categories for which scenarios B1, B2 or B3 is deemed a plausible baseline alternative, project participants shall demonstrate that this is a realistic and credible alternative scenario. To this end, one of the following procedures should be applied:
 - Demonstrate that there is an abundant surplus of the type of biomass residue in the region of the project activity which is not utilized. For this purpose, demonstrate that the quantity of that type of biomass residues available in the region is at least 25% larger than the quantity of biomass residues of that type which is utilized in the region (e.g. for energy generation or as feedstock), including the project plant;
 - Demonstrate for the sites from where biomass residues are sourced that the biomass residues have not been collected or utilized (e.g. as fuel, fertilizer or feedstock) but have been dumped and left to decay, land-filled or burnt without energy generation (e.g. field burning) prior to their use under the project activity. This approach is only applicable to biomass residues categories for which project participants can clearly identify the site from where the biomass residues are sourced.
- The scenarios B1, B2 or B3 can only be regarded as a plausible baseline scenario for a certain category of biomass residues, if the project participants can demonstrate that at least one of the two approaches above are fulfilled. Otherwise, the baseline scenario for this particular biomass residues category should be considered as B8, and a leakage penalty will be applied when calculating leakage emissions.
- If during the crediting period, new categories of biomass residues of the type B1, B2 or B3 are used in the project activity which were not listed at the validation stage, e.g. due to new sources of biomass residues, the baseline scenario for those types of biomass residues should be assessed using the procedures outlined in this guidance for each category of biomass residues.

In case of scenarios type P, H and B, for the purpose of identifying relevant alternative scenarios, provide an overview of *other* technologies or practices that provide outputs or services with comparable quality, properties and application areas as the proposed CDM project activity and that have been implemented previously or are currently underway in the relevant geographical area. The relevant geographical area should in principle be the host country of the proposed CDM project activity. A region within the country could be the relevant geographical area if the framework conditions vary significantly within the country. However, the relevant geographical area should include preferably ten facilities (or projects) that provide outputs or services with comparable quality, properties and application areas as the proposed CDM project activity. If less than ten facilities (or projects) that provide outputs or services with comparable quality, properties and application areas as the proposed CDM project activity are found in the region/host country, the geographical area may be expanded to an area that covers if possible, ten such facilities (or projects). In cases where the above described definition of geographical area is not suitable, the project proponents should provide an alternative definition of geographical area. Other registered CDM project activities are not to be included in this analysis. Provide relevant documentation to support the results of the analysis.

Identify realistic combinations of scenarios for electric power generation, heat generation and use of biomass residues.

Outcome of Step 1a: List of plausible alternative scenarios to the project activity

Sub-step 1b: Consistency with mandatory applicable laws and regulations

The alternative(s) shall be in compliance with all mandatory applicable legal and regulatory requirements, even if these laws and regulations have objectives other than GHG reductions, e.g. to mitigate local air pollution.⁶ This sub-step does not consider national and local policies that do not have legally-binding status.

If an alternative does not comply with all mandatory applicable legislation and regulations, then show that, based on an examination of current practice in the country or region in which the mandatory law or regulation applies, those applicable mandatory legal or regulatory requirements are systematically not enforced and that non-compliance with those requirements is widespread in the country. If this cannot be shown, then eliminate the alternative from further consideration.

If the proposed project activity is the only alternative amongst the ones considered by the project participants that is in compliance with all mandatory regulations with which there is general compliance, then the proposed CDM project activity is not additional.

Outcome of Step 1b: List of alternative scenarios to the project activity that are in compliance with mandatory legislation and regulations taking into account the enforcement in the region or country.

Proceed to Step 2 (Barrier analysis).

Step 2: Barrier analysis

This step serves to identify barriers and to assess which alternatives are prevented by these barriers. Apply the following sub-steps:

Sub-step 2a: Identify barriers that would prevent the implementation of alternative scenarios

Establish a complete list of realistic and credible barriers that may prevent alternative scenarios to occur. Such realistic and credible barriers may include:

- Investment barriers, other than insufficient financial returns as analyzed in Step 3, *inter alia*:
 - For alternatives undertaken and operated by private entities: Similar activities have only been implemented with grants or other non-commercial finance terms. Similar activities are defined as activities that rely on a broadly similar technology or practices, are of a similar scale, take place in a comparable environment with respect to regulatory framework and are undertaken in the relevant geographical area, as defined in Sub-step 1a above;

⁶ For example, an alternative would be non-complying in a country where this scenario would imply violations of safety or environmental regulations.

- No private capital is available from domestic or international capital markets due to real or perceived risks associated with investments in the country where the project activity is to be implemented, as demonstrated by the credit rating of the country or other country investment reports of reputed origin.
- Technological barriers, *inter alia*:
 - Skilled and/or properly trained labor to operate and maintain the technology is not available in the relevant geographical area, which leads to an unacceptably high risk of equipment disrepair, malfunctioning or other underperformance;
 - Lack of infrastructure for implementation and logistics for maintenance of the technology (e.g. natural gas can not be used because of the lack of a gas transmission and distribution network);
 - Risk of technological failure: the process/technology failure risk in the local circumstances is significantly greater than for other technologies that provide services or outputs comparable to those of the proposed CDM project activity, as demonstrated by relevant scientific literature or technology manufacturer information;
 - The particular technology used in the proposed project activity is not available in the relevant geographical area.
- Lack of prevailing practice:
 - The alternative is the “first of its kind”.

Outcome of Step 2a: List of barriers that may prevent one or more alternative scenarios to occur.

Sub-step 2b: Eliminate alternative scenarios which are prevented by the identified barriers

Identify which alternative scenarios are prevented by at least one of the barriers listed in Sub-step 2a, and eliminate those alternative scenarios from further consideration. All alternative scenarios shall be compared to the same set of barriers. The assessment of the significance of barriers should take into account the level of access to and availability of information, technologies and skilled labour in the specific context of the industry where the project type is located. For example, projects located in sectors with small and medium sized enterprises may not have the same means to overcome technological barriers as projects in a sector where typically large or international companies operate.

Outcome of Step 2b: List of alternative scenarios to the project activity that are not prevented by any barrier.

In applying Sub-steps 2a and 2b, provide transparent and documented evidence, and offer conservative interpretations of this evidence, as to how it demonstrates the existence and significance of the identified

barriers and whether alternative scenarios are prevented by these barriers. The type of evidence to be provided should include at least one of the following:

- (a) Relevant legislation, regulatory information or industry norms;
- (b) Relevant (sectoral) studies or surveys (e.g. market surveys, technology studies, etc) undertaken by universities, research institutions, industry associations, companies, bilateral/multilateral institutions, etc;
- (c) Relevant statistical data from national or international statistics;
- (d) Documentation of relevant market data (e.g. market prices, tariffs, rules);
- (e) Written documentation from the company or institution developing or implementing the CDM project activity or the CDM project developer, such as minutes from Board meetings, correspondence, feasibility studies, financial or budgetary information, etc;
- (f) Documents prepared by the project developer, contractors or project partners in the context of the proposed project activity or similar previous project implementations;
- (g) Written documentation of independent expert judgements from industry, educational institutions (e.g. universities, technical schools, training centres), industry associations and others.

Outcome of Step 2: If there is only one alternative scenario that is not prevented by any barrier, and if this alternative is the proposed project activity undertaken without being registered as a CDM project activity, then the project activity is not additional.

If there is only one alternative scenario that is not prevented by any barrier, and if this alternative is not the proposed project activity undertaken without being registered as a CDM project activity, then this alternative scenario is identified as the baseline scenario. Explain – using qualitative or quantitative arguments – how the registration of the CDM project activity will alleviate the barriers that prevent the proposed project activity from occurring in the absence of the CDM. If the CDM alleviates the identified barriers that prevent the proposed project activity from occurring, proceed to Step 4, otherwise the project activity is not additional.

If there are still several alternative scenarios remaining, including the proposed project activity undertaken without being registered as a CDM project activity, proceed to Step 3 (investment analysis).

If there are still several alternative scenarios remaining, but which do not include the proposed project activity undertaken without being registered as a CDM project activity, explain – using qualitative or quantitative arguments – how the registration of the CDM project activity will alleviate the barriers that prevent the proposed project activity from occurring in the absence of the CDM. If the CDM alleviates the identified barriers that prevent the proposed project activity from occurring, project participants may choose to either:

- Option 1: Go to Step 3 (investment analysis); or
- Option 2: Identify the alternative with the lowest emissions⁷ (i.e., the most conservative) as the baseline scenario, and proceed to Step 4.

If the CDM does not alleviate the identified barriers that prevent the proposed project activity from occurring, then the project activity is not additional.

⁷ The respective emissions should be determined in accordance with the procedures in this methodology.

Step 3: Investment analysis

The objective of Step 3 is to compare the economic or financial attractiveness of the alternative scenarios remaining after Step 2 by conducting an investment analysis. The analysis should include all alternative scenarios remaining after Step 2, including scenarios where the project participants do not undertake an investment (e.g. a combination of B1 and P7).

Identify the financial indicator, such as IRR, NPV, cost benefit ratio, or unit cost of service (e.g., levelized cost of electricity production in \$/kWh or levelized cost of delivered heat in \$/GJ) most suitable for the project type and decision-making context. If one of the alternative scenarios remaining after Step 2 corresponds to the situation where the project participants do not undertake any investment, then use either the NPV or the IRR as financial indicator in the analysis.

Calculate the suitable financial indicator for all alternative scenarios remaining after Step 2. Include all relevant costs (including, for example, the investment cost, the operations and maintenance costs), and revenues (including subsidies/fiscal incentives,⁸ ODA, etc. where applicable), and, as appropriate, non-market costs and benefits in the case of public investors if this is standard practice for the selection of public investments in the host country.

For an alternative which does not involve any investment by the project participants, use the following values for the financial indicator:

- If the financial indicator is the NPV: assume a value of NPV equal to zero;
- If the financial indicator is the IRR: use as the IRR the financial benchmark, as determined through the options (a) to (e) below.

The financial/economic analysis shall be based on parameters that are standard in the market, considering the specific characteristics of the project type, but not linked to the subjective profitability expectation or risk profile of a particular project developer. In the particular case where the project activity can only be implemented by the project participant, the specific financial/economic situation of the company undertaking the project activity can be considered.

The discount rate (in the case of the NPV) or the financial benchmark (in the case of the IRR) shall be derived from:

- (a) Government bond rates, increased by a suitable risk premium to reflect private investment and/or the project type, as substantiated by an independent (financial) expert or documented by official publicly available financial data;
- (b) Estimates of the cost of financing and required return on capital (e.g. commercial lending rates and guarantees required for the country and the type of project activity concerned), based on bankers views and private equity investors/funds' required return on comparable projects;
- (c) A company internal financial benchmark (weighted average cost of capital of the company), only in the particular case that the project activity can only be implemented by the project participant. The project developers shall demonstrate that this financial benchmark has been consistently used in the past, i.e. that project activities under similar conditions developed by the same company used the same financial benchmark;

⁸ Note that according to guidance by the EB (EB 22, Annex 3), subsidies and incentives may be excluded from consideration in certain cases.

- (d) A government/officially approved financial benchmark where, it can be demonstrated that such financial benchmarks are used for investment decisions;
- (e) Any other indicators, if the project participants can demonstrate that the above options are not applicable and their indicator is appropriately justified.

Present the investment analysis in a transparent manner and provide all the relevant assumptions, preferably in the CDM-PDD, or in separate annexes to the PDD, so that a reader can reproduce the analysis and obtain the same results. Refer to critical techno-economic parameters and assumptions (such as capital costs, fuel prices, lifetimes, and discount rate or cost of capital). Justify and/or cite assumptions in a manner that can be validated by the DOE. In calculating the financial indicator, the risks of the alternative scenarios can be included through the cash flow pattern, subject to project-specific expectations and assumptions (e.g., insurance premiums can be used in the calculation to reflect specific risk equivalents). Assumptions and input data for the investment analysis shall not differ across alternative scenarios, unless differences can be well substantiated.

Present in the CDM-PDD submitted for validation a clear comparison of the financial indicator for all alternative scenarios and rank the alternative scenarios according to the financial indicator.

Include a sensitivity analysis to assess whether the conclusion regarding the financial attractiveness is robust to reasonable variations in the critical assumptions. The investment comparison analysis provides a valid argument in identifying the baseline scenario only if it consistently supports (for a realistic range of assumptions) the conclusion that one alternative is the most economically and/or financially attractive.

Outcome of Step 3: Ranking of the short list of alternative scenarios according to the most suitable financial indicator, taking into account the results of the sensitivity analysis.

If the investment analysis, supported by the sensitivity analysis, is not conclusive, then the alternative scenario to the project activity with least emissions⁷ among the alternative scenarios is considered as baseline scenario. If the investment analysis, supported by the sensitivity analysis, is conclusive, then the most economically or financially attractive alternative scenario is considered as baseline scenario. If the alternative considered as baseline scenario is the “proposed project activity undertaken without being registered as a CDM project activity”, then the project activity is not additional. Otherwise, proceed to Step 4.

Step 4: Common practice analysis

The previous steps shall be complemented with an analysis of the extent to which the proposed project type (e.g. technology or practice) has already diffused in the relevant sector and geographical area. This test is a credibility check to demonstrate additionality which complements the barrier analysis (Step 2) and, where applicable, the investment analysis (Step 3).

Provide an analysis to which extent similar activities to the proposed CDM project activity have been implemented previously or are currently underway. Similar activities are defined as activities (i.e., technologies or practices) that are of similar scale, take place in a comparable environment, *inter alia*, with respect to the regulatory framework and are undertaken in the relevant geographical area, as defined in Sub-step 1a above. Other registered CDM project activities are not to be included in this analysis. Provide documented evidence and, where relevant, quantitative information. On the basis of that analysis,

describe whether and to which extent similar activities have already diffused in the relevant geographical area.

If similar activities to the proposed project activity are identified, then compare the proposed project activity to the other similar activities and assess whether there are essential distinctions between the proposed project activity and the similar activities. If this is the case, point out and explain the essential distinctions between the proposed project activity and the similar activities and explain why the similar activities enjoyed certain benefits that rendered them financially attractive (e.g., subsidies or other financial flows) and which the proposed project activity can not use or why the similar activities did not face barriers to which the proposed project activity is subject.

Essential distinctions may include a serious change in circumstances under which the proposed CDM project activity will be implemented when compared to circumstances under which similar projects were carried out. For example, new barriers may have arisen, or promotional policies may have ended, leading to a situation in which the proposed CDM project activity would not be implemented without the incentive provided by the CDM. The change must be fundamental and verifiable.

Outcome of Step 4: If Step 4 is satisfied, i.e. (i) similar activities cannot be observed or (ii) similar activities are observed but essential distinctions between the proposed CDM project activity and similar activities can reasonably be explained, then the proposed project activity is additional.

If Step 4 is not satisfied, i.e. similar activities can be observed and essential distinctions between the proposed CDM project activity and similar activities cannot reasonably be explained, then the proposed CDM project activity is not additional.

Emission Reductions

Emission reductions are calculated as follows:

$$\text{Eq. 1: } ER_y = BE_y - PE_y - LE_y$$

Where:

ER_y = Emissions reductions in year y (tCO₂).

BE_y = Baseline emissions in year y (tCO₂).

PE_y = Project emissions in year y (tCO₂).

LE_y = Leakage emissions in year y (tCO₂).

For ease of reference, all data required for the calculation of project, baseline and leakage emissions are listed in Annex 1 with their corresponding data number. A schematic diagram of the project activity and the baseline scenario is presented in

Figure 1.

Baseline Emissions

Baseline emissions are calculated based on the most plausible baseline scenario identified in the “Procedure for the selection of the baseline scenario and demonstration of additionality” taking into account how power and heat would be generated, and how the biomass residues would be used, in the absence of the project activity.

In the baseline scenario biomass residues could be (i) dumped, left to decay or burnt without being used (scenarios B1, B2 and B3) or (ii) used for other applications. Related baseline emissions are only calculated in the first case, according to Step 7: Determine the baseline emissions due to uncontrolled burning or decay of biomass residues.

In the baseline scenario power and heat could be generated in three different ways:

- **Use of biomass residues at the project site.** Power and heat could be generated with biomass residues at the project site. This applies, for example, if:
 - (a) The project activity is a replacement of an existing biomass residues fired plant;
 - (b) The project activity is a capacity expansion of an existing biomass residues fired plant;
 - (c) The project activity is a fuel switch project activity where some biomass residues have already been used prior to the implementation of the project activity;
 - (d) The project activity is a retrofit of an existing biomass residues fired plant;AND/OR
- **Use of fossil fuels at the project site.** Power and heat could be generated with fossil fuels. This applies, for example, if:
 - (a) The project activity is a fuel switch from fossil fuels to biomass residues;
 - (b) In the baseline, a fossil fuel fired plant would continue to operate at the project site in parallel with a new biomass residues fired plant;AND/OR
- **Power generation in the electricity grid.** Power could be generated by power plants in the electricity grid. This applies, for example, if:
 - (a) The project activity exports electricity to the grid and no electricity would be produced at the project site in the baseline;
 - (b) The project activity results in an increase of the quantity of power produced by plants included in the project boundary and this increased power is exported to the grid or would in the baseline be purchased from the grid;

In many cases, power and heat would be generated in the baseline by a combination of these three ways and it may be difficult to clearly determine the precise mix of power generation in the grid and power or heat generation with biomass residues or fossil fuels that would have occurred in the absence of the

project activity. If power can be generated in an on-site fossil fuel power plant or can be purchased from the grid, it is particularly challenging to determine how electricity would be generated in the baseline. For example, to what extent an existing coal power plant is dispatched and to what extent electricity is purchased from the grid can depend on the prices for electricity and coal which change over time.

For this reason, this methodology adopts a conservative approach and assumes that biomass residues, if available, would be used in the baseline as a priority for the generation of power and heat. Furthermore, it is assumed that the heat provided by heat generators is used first in heat engines which operate in cogeneration mode, then in thermal applications to satisfy the heat demand, and after that in heat engines which operate for the generation of power only.

Based on these assumptions, baseline emissions are calculated as follows:

Eq. 2:

$$BE_y = EL_{BL,GR,y} \cdot EF_{EG,GR,y} + \sum_f FF_{BL,HG,y,f} \cdot EF_{FF,y,f} + EL_{BL,FF/GR,y} \cdot \min(EF_{EG,GR,y}, EF_{EG,FF,y}) + BE_{BR,y}$$

Where:

BE_y = Baseline emissions in year y (tCO₂).

$EL_{BL,GR,y}$ = Baseline minimum electricity generation in the grid in year y (MWh).

$EF_{EG,GR,y}$ = Grid emission factor in year y (tCO₂/MWh).

$FF_{BL,HG,y,f}$ = Baseline fossil fuel demand for process heat in year y (GJ).

$EF_{FF,f,y}$ = CO₂ emission factor for fossil fuel type f in year y (tCO₂/GJ).

$EL_{BL,FF/GR,y}$ = Baseline uncertain electricity generation in the grid or on-site in year y (MWh).

$EF_{EG,FF,y}$ = CO₂ emission factor for electricity generation with fossil fuels at the project site in the baseline in year y (tCO₂/MWh).

$BE_{BR,y}$ = Baseline emissions due to disposal of biomass residues in year y (tCO₂e).

y = Year of the crediting period.

f = Fossil fuel type.

The algorithm used to determine the data above can be summarized as follows:

- Step 1: Determine the baseline biomass availability and baseline generation and capacity constraints for process heat and power;
- Step 2: Determine the minimum baseline electricity generation in the grid;
- Step 3: Determine the baseline biomass-based heat and power generation;
- Step 4: Determine the baseline demand for fossil fuels to meet the balance of process heat and the corresponding electricity generation;
- Step 5: Determine the emission factors of electricity generation;
- Step 6: Determine the efficiencies of heat generators, and efficiencies and heat-to-power ratio of heat engines;
- Step 7: Determine the baseline emissions due to uncontrolled burning or decay of biomass residues

- Step 8: Calculate baseline emissions.

A flow chart is presented in Figure 2 for ease of reference.

Figure 2 - Flow chart for the calculation of baseline emissions

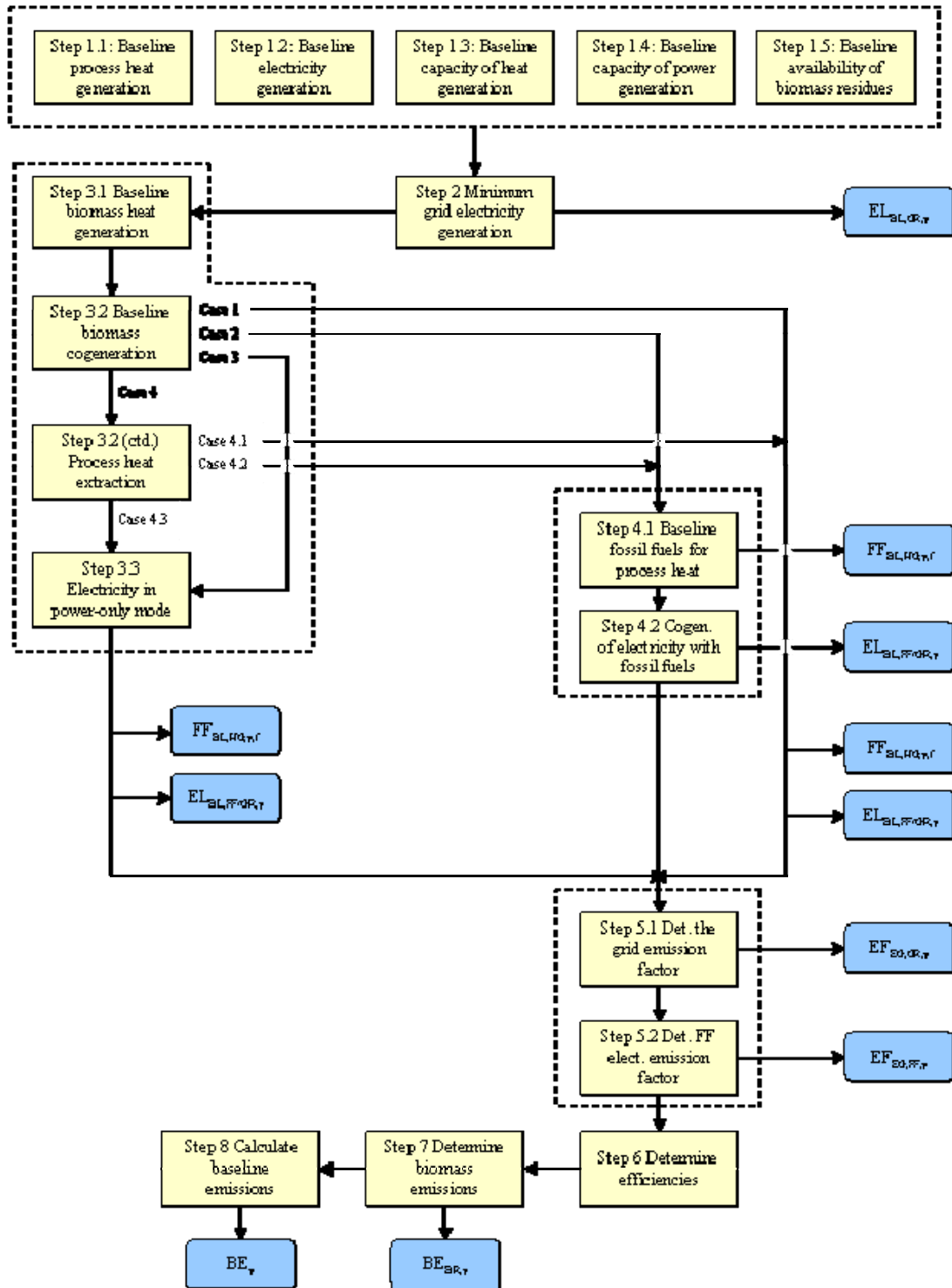

Step 1: Determine the baseline biomass availability and baseline generation and capacity constraints for process heat and power***Step 1.1: Determine total baseline process heat generation***

The amount of process heat that would be generated in the baseline in year y ($HO_{BL,y}$) is determined as the difference of the enthalpy of the process heat (steam or hot water) supplied to process heat loads in the project activity minus the enthalpy of the feed-water, the boiler blow-down and any condensate return to the heat generators. The respective enthalpies should be determined based on the mass (or volume) flows, the temperatures and, in case of superheated steam, the pressure. Steam tables or appropriate thermodynamic equations may be used to calculate the enthalpy as a function of temperature and pressure.

Step 1.2: Determine total baseline electricity generation

The amount of electricity that would be generated in the baseline in year y is calculated as follows:

$$\text{Eq. 3: } EL_{BL,y} = EL_{PJ,gross,y} + EL_{PJ,imp,y} - EL_{PJ,aux,y}$$

Where:

$EL_{BL,y}$ = Baseline electricity generation in year y (MWh).

$EL_{PJ,gross,y}$ = Gross quantity of electricity generated in all power plants which are located at the project site and included in the project boundary in year y (MWh).

$EL_{PJ,imp,y}$ = Project electricity imports from the grid in year y (MWh).

$EL_{PJ,aux,y}$ = Total auxiliary electricity consumption required for the operation of the power plants at the project site in year y (MWh).

y = Year of the crediting period.

$EL_{PJ,aux,y}$ shall include all electricity required for the operation of equipment related to the preparation, storage and transport of biomass residues (e.g. for mechanical treatment of the biomass, conveyor belts, driers, etc.) and electricity required for the operation of all power or heat generating plants which are located at the project site and included in the project boundary (e.g. for pumps, fans, cooling towers, instrumentation and control, etc.).

For this methodology, it is assumed that transmission and distribution losses in the electricity grid are not influenced significantly by the project activity and are therefore not accounted for.

Step 1.3: Determine baseline capacity of heat generation

The total capacity of heat generation available in the baseline should be calculated using the equation below. The heat generators h should be obtained from the baseline scenario identified using the “Procedure for the selection of the baseline scenario and demonstration of additionality”.

$$\text{Eq. 4: } CAP_{HG,total} = 8,760 \cdot \sum_h CAP_{HG,h} \cdot LFC_{HG,h}$$

Where:

$CAP_{HG,total}$ = Baseline heat generation capacity (GJ).

$CAP_{HG,h}$ = Baseline capacity of heat generator h (GJ/h).

$LFC_{HG,h}$ = Baseline load factor of heat generator h (ratio).

h = Heat generator in the baseline scenario.

Step 1.4: Determine baseline capacity of electricity generation

The total capacity of electricity generation available in the baseline should be calculated using the equation below. The heat engines i and j should be obtained from the baseline scenario identified using the “Procedure for the selection of the baseline scenario and demonstration of additionality” and the load factors should take into account seasonal operational constraints as well as other technical constraints in the system (e.g. availability of heat to drive heat engines).

$$\text{Eq. 5: } CAP_{EG,total} = 8,760 \cdot \left(\sum_i CAP_{EG,CG,i} \cdot LFC_{EG,CG,i} + \sum_j CAP_{EG,PO,j} \cdot LFC_{EG,PO,j} \right)$$

Where:

$CAP_{EG,total}$ = Baseline electricity generation capacity (MWh).

$CAP_{EG,CG,i}$ = Baseline electricity generation capacity of heat engine i (MW).

$LFC_{EG,CG,i}$ = Baseline load factor of heat engine i (ratio).

$CAP_{EG,PO,j}$ = Baseline electricity generation capacity of heat engine j (MW).

$LFC_{EG,PO,j}$ = Baseline load factor of heat engine j (ratio).

i = Cogeneration-type heat engine in the baseline scenario.

j = Power-only-type heat engine in the baseline scenario.

Step 1.5: Determine the baseline availability of biomass residues

Where the baseline scenario includes the use of biomass residues for the generation of power and/or heat, the amount of biomass residues of category n that would be available in the baseline in year y ($BR_{B4,n,y}$) has to be determined.

The determination of this parameter shall be based on the monitored amounts of biomass residues used for power and/or heat generation in the project boundary for which B4 has been identified as the most plausible baseline scenario in the CDM-PDD (as per Table 2 above). The biomass residues quantities used should be monitored separately for (a) each type of biomass residue (e.g. sugarcane bagasse, rice husks, empty fruit bunches, etc.) and each source (e.g. produced on-site, obtained from biomass residues suppliers, obtained from a biomass residues market, obtained from an identified biomass residues producer, etc.).

Where the whole amount of biomass residues of one particular type and from one particular source would be used in the baseline in clearly identifiable baseline heat generators, the monitored quantities of biomass residues used in the project can be directly allocated to those heat generators in the baseline scenario. However, the following situations require particular attention:

- One biomass residue type from one particular source could be used in the baseline in two or more heat generators. In this case, the use of this biomass residue type from this source has to be allocated to the different heat generators should they have different efficiencies;
- One biomass residue type from one particular source could have two different fates in the baseline scenario. The biomass categories 1 and 2 in Table 2 on page 11 illustrate this situation: the rice husks are obtained from one source but would in the baseline partly be dumped (B1) and partly be used for power generation (B4). This can apply, for example, if parts of one biomass residue type were already collected prior to the implementation of the project activity while another part was not needed and thus dumped, left to decay or burnt. In this case, it is necessary to allocate the biomass residue quantity used under the project to the following fates in the baseline scenario:
 - (a) Power or heat generation (B4), or
 - (b) Dumping, leaving to decay or burning (B1, B2 and/or B3), or
 - (c) Scenarios required for the purpose of calculating leakage effects: other fates (B5 - B8).

Where one of these situations arises, the project participants should specify and justify in the CDM-PDD in a transparent manner how the relevant allocations should be made. The approaches used should be consistent with the identified baseline scenario and reflect the particular situation of the underlying project activity. In doing so, the following allocation rules should be adhered to:

- The sum of biomass residues used in the baseline for power or heat generation in all heat generators shall correspond to the total amount of biomass residues which are used under the project activity and for which the baseline scenario is B4;
- The allocation of biomass residue should be undertaken in a conservative manner. This means that in case of uncertainty an allocation rule should be favoured that tends to result in lower emission reductions.
- In the case a biomass residues type from one particular source has been used prior to the implementation of the project activity partly in heat generators operated at the project site (scenario B4) and partly has been dumped, left to decay or burnt (scenarios B1, B2, B3) and if this situation would continue in the baseline scenario, then use, as a conservative approach to address the uncertainty associated with such an allocation, the maximum value among the following two approaches for the quantity of biomass residue of category n allocated to scenario B4:
 - (a) The highest annual historical use of that biomass residue type from that source for power and/or heat generation at the project site observed in the most recent three calendar years prior to the implementation of the project activity; and
 - (b) In the case of projects that use biomass residues from a on-site production process (e.g. production of sugar cane or rice), calculated as follows:

$$BR_{B4,n,y} = P_y \cdot \text{MAX} \left\{ \frac{BR_{\text{HIST},n,x}}{P_x}, \frac{BR_{\text{HIST},n,x-1}}{P_{x-1}}, \frac{BR_{\text{HIST},n,x-2}}{P_{x-2}} \right\}$$

Where:

$BR_{B4,n,y}$ = Quantity of biomass residues of category n used in the project activity in year y for which the baseline scenario is B4 (tonne on dry-basis).

$BR_{HIST,n,x}$ = Quantity of biomass residues of category n used for power or heat generation at the project site in year x prior to the implementation of the project activity (tonnes on dry-basis).

P_y = Quantity of the main product of the production process (e.g. sugar cane, rice) produced in year y from plants operated at the project site.

P_x = Quantity of the main product of the production process (e.g. sugar cane, rice) produced in year x from plants operated at the project site.

y = Year of the crediting period.

x = Last calendar year prior to the start of the crediting period.

n = Biomass residue category.

Step 2: Determine the minimum baseline electricity generation in the grid

The calculation of the minimum amount of electricity that would be generated in the grid in the baseline is based on the assumption that the amount of electricity generated on-site in the baseline cannot be higher than the installed capacity of power generation available in the baseline scenario. Therefore, the following equation should be used:

$$\text{Eq. 6: } EL_{BL,GR,y} = \max(0, EL_{BL,y} - CAP_{EG,total})$$

Where:

$EL_{BL,GR,y}$ = Baseline minimum electricity generation in the grid in year y (MWh).

$EL_{BL,y}$ = Baseline electricity generation in year y (MWh).

$CAP_{EG,total}$ = Baseline electricity generation capacity (MWh).

For baseline alternatives not connected to the grid or otherwise technically or legally impossible to export power to the grid $EL_{BL,GR,y} = 0$.

Step 3: Determine the baseline biomass-based heat and power generation

Step 3.1: Determine the baseline biomass-based heat generation

It is assumed that the use of biomass residues for which scenario B4 has been identified as the baseline scenario ($BR_{B4,n,y}$) would be prioritized over the use of any fossil fuels in the baseline. From that assumption, the equivalent amount of heat that would be generated with biomass residues ($HG_{BL,BR,y}$) should be determined.

Considering that the several heat generators and different categories of biomass residues might be identified as part of the baseline scenario, the prioritization of heat generators use and the allocation of biomass residues to different heat generators may be challenging and much dependent on specific site conditions. For that reason, the methodology proposes general principles that should be adhered to in order to determine the prioritization and allocation, which still leave room for technical constraints to be reflected given specific site conditions.

In order to do that follow the procedure below:

- Prepare a list of all heat generators that would use biomass residues in the baseline scenario. The list should include both biomass-based and co-fired heat generators;
- Allocate the biomass types and quantities for which B4 has been identified as the baseline scenario ($BR_{B4,n,y}$) to the different heat generators ($BR_{B4,n,h,y}$). In doing so, the following principles should be adhered to:
 - Where a biomass residue type can technically be used in more than one heat generator, it should be assumed that it is allocated from the most efficient to the less efficient heat generators to the maximum extent possible, taking into account any technical and operational constraints;
 - Where a biomass residue type can technically be used in both heat generators which do not require co-firing fossil fuels and heat generators which require co-firing fossil fuels, it should be assumed that it is to the maximum extent possible used in the heat generator which does not require co-firing fossil fuels, taking into account any technical and operational constraints. Any remaining biomass residue quantities are then allocated to the subsequent heat generators which require co-firing fossil fuels;
 - In both cases, if different types of biomass residues result in different levels of heat generation efficiency, the allocation of biomass residues should be guided by the principle that the biomass residues would be allocated so as to maximize the heat generation efficiency of the set of heat generators;
 - One particular case of technical constraint is that of heat generators that require that a minimum amount of fossil fuels be (co-)fired for heat generation. In that case the project participant may wish to: (i) clearly identify the fossil fuel type and quantity required due to this technical constraint; (ii) add the identified quantity to the parameter $FF_{BL,HG,y,f}$; (iii) determine the heat generation from this quantity of fossil fuel based on the efficiency of the heat generator; and (iv) add the calculated heat generation to the parameter $HG_{BL,BR,y}$;
 - Document and justify in the CDM-PDD in a transparent manner how the allocation of biomass residue types and quantities to heat generators will be performed during monitoring.
- Calculate the amount of heat generated with biomass residues based on the allocation above using the following equations:

$$\text{Eq. 7: } HG_{BL,BR,y} = \sum_h \sum_n (BR_{B4,n,h,y} \cdot NCV_{BR,n,y} \cdot \eta_{BL,HG,BR,h})$$

Subject to,

$$\text{Eq. 8: } \sum_h \sum_n BR_{B4,n,h,y} = \sum_n BR_{B4,n,y}, \text{ i.e. the biomass residues used in each heat generator should not exceed the total amount of biomass residues available.}$$

Eq. 9:
$$\sum_n (BR_{B4,n,h,y} \cdot NCV_{BR,n,y} \cdot \eta_{BL,HG,BR,h}) \leq 8,760 \cdot CAP_{HG,h} \cdot LFC_{HG,h}$$
, i.e. the heat generation in each heat generator should not exceed the total capacity of the heat generator;

Where:

$HG_{BL,BR,y}$ = Baseline biomass-based heat generation in year y (GJ).

$BR_{B4,n,h,y}$ = Quantity of biomass residues of category n used in heat generator h in year y with baseline scenario B4 (tonne on dry-basis).

$NCV_{BR,n,y}$ = Net calorific value of biomass residue of category n in year y (GJ/tonne on dry-basis).

$\eta_{BL,HG,BR,h}$ = Baseline biomass-based heat generation efficiency of heat generator h (ratio).

$BR_{B4,n,y}$ = Quantity of biomass residues of category n used in the project activity in year y for which the baseline scenario is B4 (tonne on dry-basis).

$CAP_{HG,h}$ = Baseline capacity of heat generator h (GJ/h).

$LFC_{HG,h}$ = Baseline load factor of heat generator h (ratio).

y = Year of the crediting period.

h = Heat generator in the baseline scenario.

Step 3.2: Determine the baseline biomass-based cogeneration of process heat and electricity and heat extraction

It is assumed that cogeneration of process heat and power using biomass-based heat ($HG_{BL,BR,y}$) would be prioritized over the use of fossil fuels for the generation of process heat and power on-site. From that assumption the equivalent amount of electricity ($EL_{BL,BR,CG,y}$) and process heat ($HO_{BL,BR,CG,y}$) that would be generated are determined.

Considering that the several heat engines of different types might be identified as part of the baseline scenario, the prioritization of heat engines use may be challenging and much dependent on specific site conditions. For that reason, the methodology proposes general principles that should be adhered to in order to determine the prioritization of use, which still leave room for technical constraints to be reflected given specific site conditions.

In order to do that follow the procedure below:

- Prepare a list containing the heat engines identified in the baseline scenario for which heat and power can be co-generated. The list should contain, in case of steam cycles, only back-pressure and heat-extraction steam turbines. Condensing steam turbines should not be considered at this stage;
- Allocate the total biomass-based heat ($HG_{BL,BR,y}$) to the different heat engines ($HG_{BL,BR,y,i}$). In doing so, the following principles should be adhered to:
 - Where heat can technically be used in more than one heat engine type, it should be assumed that it is allocated so as to maximize the co-generation of process heat. For instance, in case of steam cycles, if both back-pressure and heat-extraction steam turbines are identified in the baseline, heat should be first allocated to back-pressure

turbines and then to heat-extraction turbines to the maximum extent possible, taking into account any technical and operational constraints;

- Subject to the allocation rule above, it should be assumed that heat is allocated from the most efficient to the less efficient heat engines to the maximum extent possible, taking into account any technical and operational constraints;
 - Document and justify in the CDM-PDD in a transparent manner how the allocation of biomass-based heat to heat engines will be performed during monitoring.
- Calculate the amount of electricity and process heat generation based on the allocation above using the following equations:

$$\text{Eq. 10: } EL_{BL,BR,CG,y} = \sum_i (\eta_{BL,EG,CG,i} \cdot HG_{BL,BR,CG,y,i})$$

$$\text{Eq. 11: } HO_{BL,BR,CG,y} = 3.6 \cdot \sum_i (HPR_{BL,i} \cdot \eta_{BL,EG,CG,i} \cdot HG_{BL,BR,CG,y,i})$$

Subject to,

$$\text{Eq. 12: } \sum_i HG_{BL,BR,CG,y,i} \leq HG_{BL,BR,y}, \text{ i.e. the biomass-based heat used in cogeneration mode should not exceed the total biomass-based heat generated;}$$

$$\text{Eq. 13: } HO_{BL,BR,CG,y} \leq HO_{BL,y}, \text{ i.e. the process heat co-generated should not exceed the total process heat demand;}$$

$$\text{Eq. 14: } (\eta_{BL,EG,CG,i} \cdot HG_{BL,BR,CG,y,i}) \leq 8,760 \cdot CAP_{EG,CG,i} \cdot LFC_{EG,CG,i}, \text{ i.e. the electricity generation in each heat engine should not exceed the total capacity of the heat engine.}$$

Where:

$EL_{BL,BR,CG,y}$ = Baseline biomass-based co-generated electricity in year y (MWh).

$\eta_{BL,EG,CG,i}$ = Baseline electricity generation efficiency of heat engine i (MWh/GJ).

$HG_{BL,BR,CG,y,i}$ = Baseline biomass-based heat used in heat engine i in year y (GJ).

$HO_{BL,BR,CG,y}$ = Baseline biomass-based process heat co-generated in year y (GJ).

$HPR_{BL,i}$ = Baseline heat-to-power ratio of the heat engine i (ratio).

$HG_{BL,BR,y}$ = Baseline biomass-based heat generation in year y (GJ).

$HO_{BL,y}$ = Baseline process heat generation in year y (GJ).

$CAP_{EG,CG,i}$ = Baseline electricity generation capacity of heat engine i (MW).

$LFC_{EG,CG,i}$ = Baseline load factor of heat engine i (ratio).

i = Cogeneration-type heat engine in the baseline scenario.

y = Year of the crediting period.

The next step to be followed depends on the outcomes of the calculations above. Four cases are possible:

Case 3.2.1: If $HG_{BL,BR,y} = \sum_i HG_{BL,BR,CG,y,i}$ and $HO_{BL,y} = HO_{BL,BR,CG,y}$, then all the heat that would

be generated using biomass residues in the baseline would be used in cogeneration-type heat engines and would suffice to serve all process heat demand. It is assumed then that the use of fossil fuels on-site in the baseline scenario would be uncertain (except for the amount required due to technical constraints) because it would depend on a number of factors that are not taken into account in this methodology, particularly on the relative prices of on-site electricity generation using fossil fuels and the electricity price in the grid. In order to estimate the baseline parameters that result project participants should:

- define $EL_{BL,FF/GR,y} = EL_{BL,y} - EL_{BL,GR,y} - EL_{BL,BR,CG,y}$, $EL_{PJ,offset,y} = 0$, $FF_{BL,HG,y,f} = 0$, and,
- proceed to Step 5: Determine the emission factors of electricity generation.

Case 3.2.2: If $HG_{BL,BR,y} = \sum_i HG_{BL,BR,CG,y,i}$ and $HO_{BL,y} > HO_{BL,BR,CG,y}$, then all the heat that would

be generated using biomass residues in the baseline would be used in cogeneration-type heat engines but still some process heat demand would remain to be met. It is assumed then that the process heat balance that remains to be met would be met by using fossil fuels. In order to estimate the baseline parameters that result, project participants should:

- define $HO_{balance,FF,y} = HO_{BL,y} - HO_{BL,BR,CG,y}$,
 $EL_{balance,FF,y} = EL_{BL,y} - EL_{BL,GR,y} - EL_{BL,BR,CG,y}$, and,
- proceed to Step 4: Determine the baseline demand for fossil fuels to meet the balance of process heat and the corresponding electricity generation.

Case 3.2.3: If $HG_{BL,BR,y} > \sum_i HG_{BL,BR,CG,y,i}$ and $HO_{BL,y} = HO_{BL,BR,CG,y}$, then all process heat demand

would be met with biomass-based heat in the baseline and still there would be some biomass-based heat to be used. It is assumed then that this heat would be used for generation of power in power-only mode, i.e. without cogeneration of process heat. In order to estimate the baseline parameters that result project participants should:

- define $HG_{balance,BR,PO,y} = HG_{BL,BR,y} - \sum_i HG_{BL,BR,CG,y,i}$,
 $EL_{balance,PO,y} = EL_{BL,y} - EL_{BL,GR,y} - EL_{BL,BR,CG,y}$, and,
- proceed to Step 3.3: Determine the baseline biomass-based electricity generated in power-only mode.

Case 3.2.4: If $HG_{BL,BR,y} > \sum_i HG_{BL,BR,CG,y,i}$ and $HO_{BL,y} > HO_{BL,BR,CG,y}$, then there would be biomass-

based heat in the baseline that could still be used and process heat demand to be met. It is assumed then that this balance of biomass-based heat would be extracted from the heat header and used to meet the process heat demand without co-generation of power. Three cases should thus be considered:

Case 3.2.4.1: If $HO_{BL,y} - HO_{BL,BR,CG,y} = \frac{h_{LOW}}{h_{HIGH}} \cdot \left(HG_{BL,BR,y} - \sum_i HG_{BL,BR,CG,y,i} \right)$, i.e. the

balance of biomass-based heat (right-hand side of the equation) equals the remaining demand for process heat (left-hand side of the equation). Then there is no more biomass-based heat available and the demand for process heat has been met. It is assumed then that the use of fossil fuels on-site would be uncertain in the baseline scenario (except for the amount required due to technical constraints) because it would depend on a number of factors that are not taken into account in this methodology, particularly on the relative prices of on-site electricity generation using fossil fuels and the electricity price in the grid. In order to estimate the baseline parameters that result project participants should:

- define $EL_{BL,FF/GR,y} = EL_{BL,y} - EL_{BL,GR,y} - EL_{BL,BR,CG,y}$, $EL_{PI,offset,y} = 0$, $FF_{BL,HG,y,f} = 0$, and,
- proceed to Step 5: Determine the emission factors of electricity generation.

Case 3.2.4.2: If $HO_{BL,y} - HO_{BL,BR,CG,y} > \frac{h_{LOW}}{h_{HIGH}} \cdot \left(HG_{BL,BR,y} - \sum_i HG_{BL,BR,CG,y,i} \right)$, i.e. the

balance of biomass-based heat (right-hand side of the equation) is less than the remaining demand for process heat (left-hand side of the equation). Then all biomass-based heat was used and there still remains process heat demand to be met. It is assumed then that this process heat demand would be met by using fossil fuels in the baseline. In order to estimate the baseline parameters that result project participants should:

- define $HO_{balance,FF,y} = \left(HO_{BL,y} - HO_{BL,BR,CG,y} \right) - \frac{h_{LOW}}{h_{HIGH}} \cdot \left(HG_{BL,BR,y} - \sum_i HG_{BL,BR,CG,y,i} \right)$,
 $EL_{balance,FF,y} = EL_{BL,y} - EL_{BL,GR,y} - EL_{BL,BR,CG,y}$, and,
- proceed to Step 4: Determine the baseline demand for fossil fuels to meet the balance of process heat and the corresponding electricity generation.

Case 3.2.4.3: If $HO_{BL,y} - HO_{BL,BR,CG,y} < \frac{h_{LOW}}{h_{HIGH}} \cdot \left(HG_{BL,BR,y} - \sum_i HG_{BL,BR,CG,y,i} \right)$, i.e. the

balance of biomass-based heat (right-hand side of the equation) is greater than the remaining demand for process heat (left-hand side of the equation). Then the balance of heat produced with biomass residues is greater than the balance of process heat demand, meaning that there remains some biomass-based heat to be used after the demand for process heat was met. It is assumed then that this heat would be used to generate electricity in power-only mode, i.e. without co-generation of process heat. In order to estimate the baseline parameters that result project participants should:

- define
 $HG_{balance,BR,PO,y} = \left(HG_{BL,BR,y} - \sum_i HG_{BL,BR,CG,y,i} \right) - \frac{h_{HIGH}}{h_{LOW}} \cdot \left(HO_{BL,y} - HO_{BL,BR,CG,y} \right)$,
 $EL_{balance,PO,y} = EL_{BL,y} - EL_{BL,GR,y} - EL_{BL,BR,CG,y}$, and,

- proceed to Step 3.3: Determine the baseline biomass-based electricity generated in power-only mode.

Step 3.3: Determine the baseline biomass-based electricity generated in power-only mode

If power-only-type heat engines, i.e. heat engines that produce only electricity without cogeneration of process heat, have been identified in the baseline scenario, it is assumed that the balance of heat produced using biomass residues, if any, would be used in power-only mode.

Considering that the several heat engines of different types might be identified as part of the baseline scenario, the prioritization of heat engines use may be challenging and much dependant on specific site conditions. For that reason, the methodology proposes general principles that should be adhered to in order to determine the prioritization of use, which still leave room for technical constraints to be reflected given specific site conditions.

In order to do that follow the procedure below:

- Prepare a list containing the power-only-type heat engines (i.e. heat engines that do not co-generate any process heat) identified in the baseline scenario. The list should contain, in case of steam cycles, only condensing steam turbines. Back-pressure and heat-extraction steam turbines should not be considered here;
- Allocate the balance of biomass-based heat ($HG_{balance, BR, PO, y}$) to the different heat engines ($HG_{BL, BR, PO, y, j}$). In doing so, the following principles should be adhered to:
 - Where heat can technically be used in more than one heat engine, it should be assumed that heat is allocated from the most efficient to the less efficient heat engines to the maximum extent possible, taking into account any technical and operational constraints;
 - Document and justify in the CDM-PDD in a transparent manner how the allocation of heat to heat engines will be performed during monitoring.
- Calculate the amount of electricity generated based on the allocation above using the following equations:

$$\text{Eq. 15: } EL_{BL, BR, PO, y} = \sum_i (HG_{BL, BR, PO, y, j} \cdot \eta_{BL, EG, PO, j})$$

Subject to,

$$\text{Eq. 16: } \sum_i HG_{BL, BR, PO, y, j} \leq HG_{balance, BR, PO, y}, \text{ i.e. the biomass-based heat used in the heat engines should not exceed the biomass-based heat balance;}$$

$$\text{Eq. 17: } (HG_{BL, BR, PO, y, j} \cdot \eta_{BL, EG, PO, j}) \leq 8,760 \cdot CAP_{EG, PO, j} \cdot LFC_{EG, PO, j}, \text{ i.e. the electricity generation in each heat engine should not exceed the total capacity of the heat engine.}$$

Where:

$EL_{BL,BR,PO,y}$ = Baseline biomass-based electricity (power-only) in year y (MWh).

$HG_{BL,BR,PO,y,j}$ = Baseline biomass-based heat used in heat engine j in year y (GJ).

$\eta_{BL,EG,PO,j}$ = Average electric power generation efficiency of heat engine j (MWh/GJ).

$HG_{balance,BR,PO,y}$ = Baseline biomass-based heat balance after cogeneration in year y (GJ).

$CAP_{EG,PO,j}$ = Baseline electricity generation capacity of heat engine j (MW).

$LFC_{EG,PO,j}$ = Baseline load factor of heat engine j (ratio).

The following cases are possible depending on the results of the calculations above:

Case 3.3.1: If $EL_{balance,PO,y} \geq EL_{BL,BR,PO,y}$, the amount of electricity generated on-site in the baseline is either equal to or less than the amount of electricity generated in the project scenario. In that case:

- define $EL_{BL,FF/GR,y} = EL_{balance,PO,y} - EL_{BL,BR,PO,y}$, $EL_{PJ,offset,y} = 0$, $FF_{BL,HG,y,f} = 0$, and,
- proceed to Step 5: Determine the emission factors of electricity generation.

Case 3.3.2: If $EL_{balance,PO,y} < EL_{BL,BR,PO,y}$, the amount of electricity generated on-site in the baseline exceeds the amount of electricity generated in the project scenario. If grid-export was available in the baseline, this result indicates that the project activity results in a decrease of power output which is likely to be supplied by the grid. As a consequence, project emissions in the form of generation of electricity in the grid should be accounted for via the parameter $EL_{PJ,offset,y}$. In order to continue project participants should:

- define $EL_{BL,FF/GR,y} = 0$, $EL_{PJ,offset,y} = EL_{balance,PO,y} - EL_{BL,BR,PO,y}$, $FF_{BL,HG,y,f} = 0$, and,
- proceed to Step 5: Determine the emission factors of electricity generation.

Step 4: Determine the baseline demand for fossil fuels to meet the balance of process heat and the corresponding electricity generation

Step 4.1: Determine the baseline demand for fossil fuels to meet the balance of process heat

In many cases the amount of biomass residues available is not enough to generate the heat required to meet the process heat demand. In such cases, and if fossil-fuel-based heat generators have been identified in the baseline scenario, it is assumed that the balance of process heat is met using fossil fuels, resulting in related fossil fuel baseline emissions.

Considering that several heat generators might be identified as part of the baseline scenario, the prioritization of heat generators use may be challenging and much dependent on specific site conditions. For that reason, the methodology proposes general principles that should be adhered to in order to determine the prioritization and allocation, which still leave room for technical constraints to be reflected given specific site conditions.

In order to determine the amount of fossil fuels that would be required, the procedure below should be followed:

- Prepare a list of all heat generators that would use fossil fuels in the baseline scenario. The list should contain both biomass-based and co-fired heat generators.
- Allocate the process heat balance ($HO_{balance,FF,y}$) to the different heat generators ($HG_{BL,FF,y,h}$), subject to the difference in heat content in the different heat carriers, up to the level required for meeting the balance of process heat demand. In doing so, the following principles should be adhered to:
 - Where heat can technically be generated in more than one heat generator, it should be assumed that it is generated starting from the most efficient to the less efficient heat generators to the maximum extent possible, taking into account any technical and operational constraints, including co-firing and the partial use of the heat generator in the previous steps;
 - If different types of fossil fuels can technically be used in the heat generators, the type of fossil fuel used should be guided by the principle that fossil fuels would be used so as to maximize the heat generation efficiency of the set of heat generators;
 - Document and justify in the CDM-PDD in a transparent manner how the allocation of fossil fuel types and quantities to different heat generators will be performed during monitoring.
- Estimate the amount of fossil fuels required to generated the balance of process heat based on the allocation above using the following equations:

$$\text{Eq. 18: } FF_{BL,HG,y,f} = \sum_h \left(\frac{HG_{BL,FF,y,h}}{\eta_{BL,HG,FF,h}} \right)$$

Subject to,

$$\text{Eq. 19: } \sum_h HG_{BL,FF,y,h} \leq \frac{h_{HIGH,y}}{h_{LOW,y}} \cdot HO_{balance,FF,y}, \text{ i.e. the heat generation should not exceed the balance of process heat demand, taking into account the difference in the heat content of the heat carriers;}$$

$$\text{Eq. 20: } HG_{BL,FF,y,h} \leq 8,760 \cdot CAP_{HG,h} \cdot LFC_{HG,h}, \text{ i.e. the heat generation in each heat generator should not exceed the total capacity of the heat generator;}$$

Where:

$FF_{BL,HG,y,f}$ = Baseline fossil fuel demand for process heat in year y (GJ).

$HG_{BL,FF,y,h}$ = Baseline fossil-based heat generation in heat generator h in year y (GJ).

$\eta_{BL,HG,FF,h}$ = Baseline fossil-based heat generation efficiency of heat generator h (ratio).

$HO_{balance,FF,y}$ = Balance of process heat demand after cogeneration in year y (GJ).

$CAP_{HG,h}$ = Baseline capacity of heat generator h (GJ/h).

$LFC_{HG,h}$ = Baseline load factor of heat generator h (ratio).

$h_{LOW,y}$ = Energy content of the heat carrier at the process heat demand side (GJ/tonnes) (enthalpy of steam in case of steam systems).

$h_{\text{HIGH},y}$ = Energy content of the heat carrier at the heat generator side (GJ/tonnes) (enthalpy of steam in case of steam systems).

f = Fossil fuel type.

h = Heat generator in the baseline scenario.

y = Year of the crediting period.

Step 4.2: Determine the baseline electricity cogeneration as a consequence of the generation of process heat with fossil fuels

If there is still some capacity of cogeneration, the heat generated using fossil fuels as calculated in the step above could be used in the baseline to generate some additional electricity.

Considering that the several heat engines of different types might be identified as part of the baseline scenario, the prioritization of heat engines use may be challenging and much dependent on specific site conditions. For that reason, the methodology proposes general principles that should be adhered to in order to determine the prioritization of use, which still leave room for technical constraints to be reflected given specific site conditions.

In order to determine the additional amount of electricity produced in those heat engines, the procedure below should be followed:

- Prepare a list containing the heat engines identified in the baseline scenario for which heat and power can be co-generated. The list should contain, in case of steam cycles, only backpressure and heat-extraction steam turbines. Condensing steam turbines should not be considered;
- Allocate the total fossil-fuel-based heat ($\sum_h \text{HG}_{\text{BL,FF},y,h}$) to the different heat engines ($\text{HG}_{\text{BL,FF},y,i}$). In doing so, the following principles should be adhered to:
 - Where heat can technically be used in more than one heat engine type, it should be assumed that it is allocated so as to maximize the co-generation of process heat. For instance, in case of steam cycles, if both back-pressure and heat-extraction steam turbines are identified in the baseline, heat should be first allocated to back-pressure turbines and then to heat-extraction turbines to the maximum extent possible, taking into account any technical and operational constraints, including partial use of the heat engine in previous steps;
 - Subject to the allocation rule above, it should be assumed that heat is allocated from the most efficient to the less efficient heat engines to the maximum extent possible, taking into account any technical and operational constraints;
 - Document and justify in the CDM-PDD in a transparent manner how the allocation of heat to heat generators will be performed during monitoring.
- Calculate the amount of electricity generated based on the allocation above using the following equations:

$$\text{Eq. 21: } \quad \text{EL}_{\text{BL,FF},y} = \sum_i \left(\text{HG}_{\text{BL,FF},y,i} \cdot \eta_{\text{BL,EG,CG},i} \right)$$

Subject to,

Eq. 22: $\sum_i HG_{BL,FF,y,i} \leq \sum_h HG_{BL,FF,y,h}$, i.e. the heat allocated to the heat engines should not exceed the heat generated;

Eq. 23: $(HG_{BL,FF,y,i} \cdot \eta_{BL,EG,CG,i}) \leq 8,760 \cdot CAP_{EG,CG,i} \cdot LFC_{EG,CG,i}$, i.e. the electricity generation in each heat engine should not exceed the total capacity of the heat engine.

Where:

$EL_{BL,FF,y}$ = Baseline fossil-based electricity generation in year y (MWh).

$HG_{BL,FF,y,i}$ = Baseline fossil-based heat used in heat engine i in year y (GJ).

$\eta_{BL,EG,CG,i}$ = Baseline electricity generation efficiency of heat engine i (MWh/GJ).

$HG_{BL,FF,y,h}$ = Baseline fossil-based heat generation in heat generator h in year y (GJ).

$CAP_{EG,CG,i}$ = Baseline electricity generation capacity of heat engine i (MW).

$LFC_{EG,CG,i}$ = Baseline load factor of heat engine i (ratio).

y = Year of the crediting period.

h = Heat generator in the baseline scenario.

i = Cogeneration-type heat engine in the baseline scenario.

Three cases are possible depending on the results of the calculations above:

Case 4.2.1: If $EL_{balance,FF,y} \geq EL_{BL,FF,y}$, the amount of electricity generated on-site in the baseline is either equal to or less than the amount of electricity generated in the project scenario. In order to determine the resulting baseline emissions project participants should:

- define $EL_{BL,FF/GR,y} = EL_{balance,FF,y} - EL_{BL,FF,y}$, $EL_{PJ,offset,y} = 0$, and,
- proceed to Step 5: Determine the emission factors of electricity generation.

Case 4.2.2: If $EL_{balance,FF,y} < EL_{BL,FF,y}$, the amount of electricity generated on-site in the baseline exceeds the amount of electricity generated in the project scenario. If grid-export was available in the baseline, this result indicates that the project activity results in a decrease of power output which is likely to be supplied by the grid. As a consequence, project emissions in the form of generation of electricity in the grid should be accounted for via the parameter $EL_{PJ,offset,y}$. In order to determine the resulting baseline emissions project participants should:

- define $EL_{BL,FF/GR,y} = 0$, $EL_{PJ,offset,y} = EL_{balance,FF,y} - EL_{BL,FF,y}$, and,
- proceed to Step 5: Determine the emission factors of electricity generation.

Step 5: Determine the emission factors of electricity generation

Step 5.1: Determination of the emission factor of grid electricity generation

The parameter $EF_{EG,GR,y}$ = Grid emission factor in year y (tCO₂/MWh) should be determined as the combined margin CO₂ emission factor for grid to which the project activity is connected in year y , calculated using the latest approved version of the “Tool to calculate the emission factor for an electricity system”.

Step 5.2: Determination of the emission factor of on-site electricity generation with fossil fuels

If no fossil fuel based power generation was identified as part of the baseline scenario, or if fossil fuel based power generation was identified as part of the baseline scenario, but after conducting the previous steps all capacity of power generation based on fossil fuels is used, then make $EF_{EG,FF,y} = EF_{EG,GR,y}$.

Otherwise, i.e. fossil fuel based power generation was identified as part of the baseline scenario and after conducting the previous steps some power generation capacity based on fossil fuels is left, $EF_{EG,FF,y}$ should be determined using Option A or Option B below. If fossil fuel power plants were operated at the project site prior to the implementation of the project activity, either Option A or Option B can be used. For new power plants that would be constructed at the project site in the baseline scenario, Option B should be used.

Option A: Determine $EF_{EG,FF,y}$ as per the procedure described under “Scenario B: Electricity consumption from an off-grid captive power plant” in the latest approved version of the “Tool to calculate baseline, project and/or leakage emissions from electricity consumption”, using data from the three calendar years prior to the implementation of the project activity.

Option B: Determine a default emission factor for $EF_{EG,FF}$ based on a default efficiency of the power plant that would be operated at the project site in the baseline and a default CO₂ emission factor for the fossil fuel types that would be used, as follows:

$$\text{Eq. 24:} \quad EF_{EG,FF} = 3.6 \cdot \frac{EF_{BL,CO_2,FF}}{\eta_{BL,FF}}$$

Where:

$EF_{EG,FF,y}$ = CO₂ emission factor for electricity generation with fossil fuels at the project site in the baseline in year y (tCO₂/MWh).

$EF_{BL,CO_2,FF}$ = CO₂ emission factor of the fossil fuel type that would be used for power generation at the project site in the baseline (tCO₂/GJ).

$\eta_{BL,FF}$ = Efficiency of the fossil fuel power plant(s) at the project site in the baseline.

Step 6: Determine the efficiencies of heat generators, and efficiencies and heat-to-power ratio of heat engines

The efficiencies of heat generators and heat engines should be calculated using one of the following options:

- Option 1: Default values.** Use Option F in the latest version of the “Tool to determine the baseline efficiency of thermal or electric energy generation systems” approved by the CDM Executive Board⁹.
- Option 2: Manufacturer’s data.** This option is only applicable to heat engines and heat generators that were operated at the project site prior to the implementation of the project activity (and not new equipment that would be constructed and operated at the project site in the baseline scenario). The efficiency of the heat generator or heat engine is determined based on manufacturer’s data of the efficiency under optimal operating conditions.
- Option 3: Historical records.** This option is only applicable to heat generators and heat engines that were operated at the project site for at least three calendar years prior to the implementation of the project activity. The efficiencies of heat generators and heat engines are determined based on the historical records, as follows:

Efficiency for heat generators

The efficiency for heat generators should be calculated using the following equation:

Eq. 25:

$$\eta_{BL,HG,BR,h} = \text{MAX} \left\{ \frac{HG_{BR,h,x}}{\sum_n BR_{n,h,x} \cdot NCV_{BR,n,x}} ; \frac{HG_{BR,h,x-1}}{\sum_n BR_{n,h,x-1} \cdot NCV_{BR,n,x-1}} ; \frac{HG_{BR,h,x-2}}{\sum_n BR_{n,h,x-2} \cdot NCV_{BR,n,x-2}} \right\}$$

$$\eta_{BL,HG,FF,h} = \text{MAX} \left\{ \frac{HG_{FF,h,x}}{\sum_n FF_{f,h,x} \cdot NCV_{FF,f,x}} ; \frac{HG_{FF,h,x-1}}{\sum_n FF_{f,h,x-1} \cdot NCV_{FF,f,x-1}} ; \frac{HG_{FF,h,x-2}}{\sum_n FF_{f,h,x-2} \cdot NCV_{FF,f,x-2}} \right\}$$

Where:

$\eta_{BL,HG,BR,h}$ = Baseline biomass-based heat generation efficiency of heat generator h (ratio).

$\eta_{BL,HG,FF,h}$ = Baseline fossil-based heat generation efficiency of heat generator h (ratio)

$HG_{BR,h,x}$ = Net quantity of heat generated from using biomass residues in heat generator h in year x (MWh/yr).

$HG_{FF,h,x}$ = Net quantity of heat generated from using fossil fuels in heat generator h in year x (MWh/yr).

$BR_{n,h,x}$ = Quantity of biomass residues of category n used in heat generator h in year x (tonnes on dry-basis).

$FF_{f,h,x}$ = Quantity of fossil fuel type f fired in heat generator h in year x (mass or volume unit/yr).

$NCV_{BR,n,x}$ = Net calorific value of biomass residues of category n in year x (GJ/mass or volume unit).

$NCV_{FF,f,x}$ = Net calorific value of fossil fuel type f in year x (GJ/mass or volume unit).

⁹ Where a default value is not provided for a technology a request for revision to this methodology may be submitted.

x = Last calendar year prior to the start of the crediting period.

n = Biomass residue category.

f = Fossil fuel type.

h = Heat generator in the baseline scenario.

If only biomass residues and no fossil fuels were used for heat generation in the heat generator h prior to the implementation of the project activity, then $HG_{BR,h,x}$, $HG_{BR,h,x-1}$ and $HG_{BR,h,x-2}$ can be obtained directly from historical electricity generation records.

If fossil fuels and biomass residues were used for heat generation in heat generator h prior to the implementation of the project activity, then $HG_{BR,h,x}$, $HG_{BR,h,x-1}$ and $HG_{BR,h,x-2}$ are determined as follows:

$$\text{Eq. 26: } HG_{BR,h,x} = HG_{h,x} \cdot \frac{\sum_n BR_{n,h,x} \cdot NCV_{BR,n,x}}{\sum_n BR_{n,h,x} \cdot NCV_{BR,n,x} + \sum_f FF_{f,h,x} \cdot NCV_{FF,f,x}}$$

$$HG_{FF,h,x} = HG_{h,x} \cdot \frac{\sum_f FF_{f,h,x} \cdot NCV_{FF,f,x}}{\sum_n BR_{n,h,x} \cdot NCV_{BR,n,x} + \sum_f FF_{f,h,x} \cdot NCV_{FF,f,x}}$$

Where:

$HG_{BR,h,x}$ = Net quantity of heat generated from using biomass residues in heat generator h in year x (MWh/yr).

$HG_{FF,h,x}$ = Net quantity of heat generated from using fossil fuels in heat generator h in year x (MWh/yr).

$HG_{h,x}$ = Net quantity of heat generated in heat generator h in year x (GJ/yr).

$BR_{n,h,x}$ = Quantity of biomass residues of category n used in heat generator h in year x (tonnes on dry-basis).

$FF_{f,h,x}$ = Quantity of fossil fuel type f fired in heat generator h in year x (mass or volume unit/yr).

$NCV_{BR,n,x}$ = Net calorific value of biomass residues of category n in year x (GJ/mass or volume unit).

$NCV_{FF,f,x}$ = Net calorific value of fossil fuel type f in year x (GJ/mass or volume unit).

Efficiency for heat engines

The efficiency for heat engines should be calculated using the following equation:

Eq. 27:

$$\eta_{BL,EG,CG/PO,ij} = \text{MAX} \left\{ \frac{EL_{BR,CG/PO,x,ij}}{HG_{BR,CG/PO,x,ij}}; \frac{EL_{BR,CG/PO,x-1,ij}}{HG_{BR,CG/PO,x-1,ij}}; \frac{EL_{BR,CG/PO,x-2,ij}}{HG_{BR,CG/PO,x-2,ij}} \right\}$$

Where:

$\eta_{BL,EG,CG,i}$ = Baseline electricity generation efficiency of heat engine i (MWh/GJ).

$\eta_{BL,EG,PO,j}$ = Average electric power generation efficiency of heat engine j (MWh/GJ).

$EL_{BR,CG/PO,x,i/j}$ = Quantity of electricity generated in heat engine i/j in year x (MWh).
 $HG_{BR,CG/PO,x,i/j}$ = Quantity of heat used in heat engine i/j in year x (GJ).
 x = Last calendar year prior to the start of the crediting period
 i = Cogeneration-type heat engine in the baseline scenario
 j = Power-only-type heat engine in the baseline scenario

The heat-to-power ratio of cogeneration-type heat engines (e.g. backpressure and heat-extraction steam turbines) should be calculated as follows.

Case 1: For existing heat engines with a minimum three-year operational history prior to the project activity:

$$\text{Eq. 28: } HPR_{BL,EG,CG/PO,i/j} = \text{MAX} \left\{ \frac{HO_{BR,CG/PO,x,i/j}}{EL_{BR,CG/PO,x,i/j}}, \frac{HO_{BR,CG/PO,x,i/j}}{EL_{BR,CG/PO,x,i/j}}, \frac{HO_{BR,CG/PO,x,i/j}}{EL_{BR,CG/PO,x,i/j}} \right\}$$

Where:

$HPR_{BL,i}$ = Baseline heat-to-power ratio of the heat engine i (ratio).
 $HO_{BR,CG/PO,x,i/j}$ = Quantity of process heat extracted from the heat engine i/j in year x (GJ).
 $EL_{BR,CG/PO,x,i/j}$ = Quantity of electricity generated in heat engine i/j in year x (MWh).
 x = Last calendar year prior to the start of the crediting period.
 i = Cogeneration-type heat engine in the baseline scenario.
 j = Power-only-type heat engine in the baseline scenario.

Case 2: For heat engines without a minimum three-year operational history prior to the project activity the heat-to-power ratio should be determined as per the design conditions of the plant, following the guidance provided in the “Procedure for the selection of the baseline scenario and demonstration of additionality”.

Step 7: Determine the baseline emissions due to uncontrolled burning or decay of biomass residues

The calculation of baseline emissions due to uncontrolled burning or decay of biomass residues is optional and project participants can decide whether to include these emission sources or not. If project participants wish to include these emission sources, the procedure below should be followed, and emissions from combustion of biomass residues under the project activity should be also be determined. Otherwise, this section does not need to be applied and project emissions do not need to include emissions from the combustion of biomass residues under the project activity.

Baseline emissions due to uncontrolled burning or decay of biomass residues are only determined for those categories of biomass residues for which B1, B2 or B3 has been identified as the most plausible baseline scenario, as summarized in Table 2. The guidance provided before for the determination of the baseline scenario for biomass residues and allocation of biomass residues in the baseline should be considered in determining the quantities of biomass residues for each biomass residue category.

The emissions are determined separately for biomass residues categories for which scenarios B1 and B3 (aerobic decay or uncontrolled burning) apply, and for biomass residues categories for which scenario B2 (anaerobic decay) apply:

$$\text{Eq. 29: } BE_{BR,y} = BE_{BR,B1/B3,y} + BE_{BR,B2,y}$$

Where:

$BE_{BR,y}$ = Baseline emissions due to disposal of biomass residues in year y (tCO₂e).

$BE_{BR,B1/B3,y}$ = Baseline emissions due to aerobic decay or uncontrolled burning of biomass residues in year y (tCO₂)

$BE_{BR,B2,y}$ = Baseline emissions due to anaerobic decay of biomass residues in year y (tCO₂)

Step 7.1: Determine $BE_{BR,B1/B3,y}$

For the biomass residues categories, as described in the biomass residues categories table, for which the most likely baseline scenario is either that the biomass residues would be dumped or left to decay under mainly aerobic conditions (B1), or burnt in an uncontrolled manner without utilizing them for energy purposes (B3), baseline emissions are calculated assuming, for both scenarios (aerobic decay and uncontrolled burning), that the biomass residues would be burnt in an uncontrolled manner.

Baseline emissions are calculated by multiplying the quantity of biomass residues with the net calorific value and an appropriate emission factor, as follows:

$$\text{Eq. 30: } BE_{BR,B1/B3,y} = GWP_{CH_4} \cdot \sum_n BR_{B1/B3,n,y} \cdot NCV_{BR,n,y} \cdot EF_{BR,n,y}$$

Where:

$BE_{BR,B1/B3,y}$ = Baseline emissions due to aerobic decay or uncontrolled burning of biomass residues in year y (tCO₂)

GWP_{CH_4} = Global Warming Potential of methane valid for the commitment period (tCO₂/tCH₄)

$BR_{B1/B3,n,y}$ = Quantity of biomass residues of category n used in the project activity in year y for which the baseline scenario is B1 or B3 (tonnes on dry-basis)

$NCV_{BR,n,y}$ = Net calorific value of biomass residue of category n in year y (GJ/tonne on dry-basis)

$EF_{BR,n,y}$ = CH₄ emission factor for uncontrolled burning of the biomass residues category n during the year y (tCH₄/GJ)

n = Biomass residue category

To determine the CH₄ emission factor ($EF_{BR,n,y}$), project participants may undertake measurements or use referenced default values. In the absence of more accurate information, it is recommended to use 0.0027 t CH₄ per ton of biomass as default value for the product of $NCV_{BR,n,y}$ and $EF_{BR,n,y}$.¹⁰

The uncertainty of the CH₄ emission factor ($EF_{BR,n,y}$) is in many cases relatively high. In order to reflect this and for the purpose of providing conservative estimates of emission reductions, a conservativeness factor must be applied to the CH₄ emission factor. The level of the conservativeness factor depends on the uncertainty range of the estimate for the CH₄ emission factor. The appropriate conservativeness factor from Table 3 below shall be chosen and multiplied with the estimate for the CH₄ emission factor. For example, if the default CH₄ emission factor of 0.0027 t CH₄/t biomass is used, the uncertainty can be deemed to be greater than 100%, resulting in a conservativeness factor of 0.73. Thus, in this case an emission factor of 0.001971 t CH₄/t biomass should be used.

Table 3: Conservativeness factors

¹⁰ 2006 IPCC Guidelines, Volume 4, Table 2.5, default value for agricultural residues.

Estimated uncertainty range (%)	Assigned uncertainty band (%)	Conservativeness factor where lower values are more conservative
Less than or equal to 10	7	0.98
Greater than 10 and less than or equal to 30	20	0.94
Greater than 30 and less than or equal to 50	40	0.89
Greater than 50 and less than or equal to 100	75	0.82
Greater than 100	150	0.73

Step 7.2: Determine $BE_{BR,B2,y}$

For the biomass residues categories, as described in the biomass residues categories table, for which the most likely baseline scenario is that the biomass residues would decay under clearly anaerobic conditions (case B2), project participants shall calculate baseline emissions using the latest approved version of the “Tool to determine methane emissions avoided from disposal of waste at a solid waste disposal site”. The variable $BE_{CH_4,SWDS,y}$ calculated by the tool corresponds to $BE_{BR,B2,y}$ in this methodology. The project participants shall use as waste quantities prevented from disposal ($W_{j,x}$) in the tool, those quantities of biomass residues ($BR_{n,B2,y}$) for which B2 has been identified as the most plausible baseline scenario, as summarized in the example in Table 2.

The determination of $BR_{n,B2,y}$ shall be based on the monitored amounts of biomass residues used in power plants included in the project boundary. Where all biomass residues with the baseline scenario B2 come from one particular source, the monitored quantities of biomass residues used from that source in the project plant can be directly used. Where only parts of the biomass residues from one source would be dumped under clearly anaerobic conditions (B2), an allocation should be made consistently with Table 2 above, as provided for the project activity in the CDM-PDD. The allocation should be made in a conservative manner and consistent with the guidance provided before for $BR_{B4,n,y}$. The project participants should specify and justify in the CDM-PDD in a transparent manner how the relevant allocations should be made and how $BR_{n,B2,y}$ should be determined for the relevant biomass residue category n based on the monitored quantities. The approaches used should be consistent with the identified baseline scenario and reflect the particular situation of the underlying project activity.

Step 8: Calculate baseline emissions

Calculate baseline emissions using equation Eq. 2 above.

Project emissions

For the purpose of determining GHG emissions of the project activity, project participants shall include the following emissions sources:

- Emissions from fossil fuel consumption at the project site for the generation of electric power and heat and for auxiliary loads related to the generation of electric power and heat;
- CO₂ emissions from grid-connected fossil fuel power plants in the electricity system for any electricity that is imported from the grid to the project site;
- If either $EL_{\text{balance,PO},y} < EL_{\text{BL,BR,PO},y}$ (Case 3.3.2) or $EL_{\text{balance,FF},y} < EL_{\text{BL,FF},y}$ (Case 4.2.2), CO₂ emissions from grid-connected fossil fuel power plants in the electricity system due to reduction in electricity generation at the project site as compared to the baseline scenario;
- CO₂ emissions from off-site transportation of biomass residues that are combusted in the project plant;
- If applicable, CH₄ emissions from combustion of biomass residues for electric power and heat generation at the project site;
- If applicable, emissions from anaerobic treatment of wastewater originating from the treatment of the biomass residues prior to their combustion.

Project emissions are calculated as follows:

$$\text{Eq. 31: } PE_y = PE_{\text{FF},y} + PE_{\text{GR1},y} + PE_{\text{GR2},y} + PE_{\text{TR},y} + PE_{\text{BR},y} + PE_{\text{WW},y}$$

Where:

PE_y = Project emissions in year y (tCO₂)

$PE_{\text{FF},y}$ = Emissions during the year y due to fossil fuel consumption at the project site (tCO₂)

$PE_{\text{GR1},y}$ = Emissions during the year y due to grid electricity imports to the project site (tCO₂)

$PE_{\text{GR2},y}$ = Emissions due to a reduction in electricity generation at the project site as compared to the baseline scenario in year y (tCO₂)

$PE_{\text{TR},y}$ = Emissions during the year y due to transport of the biomass residues to the project plant (tCO₂)

$PE_{\text{BR},y}$ = Emissions from the combustion of biomass residues during the year y (tCO₂e)

$PE_{\text{WW},y}$ = Emissions from wastewater generated from the treatment of biomass residues in year y (tCO₂e)

Determination of $PE_{\text{FF},y}$

The following emission sources should be included in determining $PE_{\text{FF},y}$:

- Emissions from on-site fossil fuel consumption for the generation of electric power and heat. This includes all fossil fuels used at the project site in heat generators (e.g. boilers) for the generation of electric power and heat; and,
- Emissions from on-site fossil fuel consumption of auxiliary equipment and systems related to the generation of electric power and heat. This includes fossil fuels required for the operation of auxiliary equipment related to the power and heat plants (e.g. for pumps, fans, cooling towers, instrumentation and control, etc.) which are not accounted in the first bullet, and fossil fuels required for the operation of equipment related to the preparation, storage and transportation of fuels (e.g. for mechanical treatment of the biomass, conveyor belts, driers, etc.).

The latest approved version of the “Tool to calculate project or leakage CO₂ emissions from fossil fuel combustion” should be used to calculate $PE_{\text{FF},y}$. All combustion processes j as described in the two bullets above should be included.

Determination of $PE_{\text{GR1},y}$

If electricity is imported from the grid to the project site during year y , corresponding emissions should be accounted for as project emissions, as follows:

$$\text{Eq. 32: } PE_{GR1,y} = EF_{EG,GR,y} \cdot EL_{PJ,imp,y}$$

Where:

$PE_{GR1,y}$ = Emissions during the year y due to grid electricity imports to the project site (tCO₂).

$EL_{PJ,imp,y}$ = Project electricity imports from the grid in year y (MWh).

$EF_{EG,GR,y}$ = Grid emission factor in year y (tCO₂/MWh).

Determination of $PE_{GR2,y}$

If $EL_{balance,PO,y} < EL_{BL,BR,PO,y}$ (Case 3.3.2) or $EL_{balance,FF,y} < EL_{BL,FF,y}$ (Case 4.2.2), the amount of electricity generated on-site in the baseline exceeds the amount of electricity generated in the project scenario. In such cases it is assumed that an equivalent amount of electricity is generated during year y in order to offset this reduction in electricity generation at the project site. Corresponding emissions should be accounted as project emissions as follows:

$$\text{Eq. 33: } PE_{GR2,y} = EF_{EG,GR,y} \cdot EL_{PJ,offset,y}$$

Where:

$PE_{GR2,y}$ = Emissions due to a reduction in electricity generation at the project site as compared to the baseline scenario in year y (tCO₂).

$EF_{EG,GR,y}$ = Grid emission factor in year y (tCO₂/MWh).

$EL_{PJ,offset,y}$ = Electricity that would be generated in the baseline that exceeds the generation of electricity during year y (MWh).

Determination of $PE_{TR,y}$

In cases where the biomass residues are not generated directly at the project site, project participants shall determine CO₂ emissions resulting from transportation of the biomass residues to the project plant. In many cases transportation is undertaken by vehicles. Project participants may choose between two different approaches to determine emissions: an approach based on distance and vehicle type (Option 1) or on fuel consumption (Option 2).

Option 1

Emissions are calculated on the basis of distance and the number of trips (or the average truck load):

$$\text{Eq. 34: } PE_{TR,y} = N_y \cdot AVD_y \cdot EF_{km,y}$$

or

$$\text{Eq. 35: } PE_{TR,y} = \frac{BR_{TR,y}}{TL_y} \cdot AVD_y \cdot EF_{km,y}$$

Where:

$PE_{TR,y}$ = Emissions during the year y due to transport of the biomass residues to the project plant (tCO₂)
 N_y = Number of truck trips for the transportation of biomass during the year y
 AVD_y = Average round trip distance (from and to) between the biomass residues fuel supply sites and the site of the project plant during the year y (km)
 $EF_{km,y}$ = Average CO₂ emission factor for the trucks measured during the year y (tCO₂/km)
 $BR_{TR,y}$ = Quantity of biomass residues that has been transported to the project site during the year y (tonnes of dry matter)
 TL_y = Average truck load of the trucks used during the year y

Option 2

Emissions are calculated based on the actual quantity of fossil fuels consumed for transportation.

$$\text{Eq. 36: } PE_{TR,y} = \sum_f FC_{TR,f,y} \cdot NCV_{FF,f,y} \cdot EF_{FF,f,y}$$

Where:

$PE_{TR,y}$ = Emissions during the year y due to transport of the biomass residues to the project plant (tCO₂).
 $FC_{TR,f,y}$ = Fuel consumption of fuel type f in trucks for transportation of biomass residues during the year y (mass or volume unit).
 $EF_{FF,f,y}$ = CO₂ emission factor for fossil fuel type f in year y (tCO₂/GJ).
 $NCV_{FF,f,y}$ = Net calorific value of fossil fuel type f in year y (GJ/mass or volume unit).
 f = Fossil fuel type.
 y = Year of the crediting period.

Determination of $PE_{BR,y}$

If project proponents chose to include emissions due to uncontrolled burning or decay of biomass residues ($BE_{BR,y}$) in the calculation of baseline emissions, then emissions from the combustion of biomass residues have also to be included in the project scenario. Otherwise, this emission source need not be included. Corresponding emissions are calculated as follows:

$$\text{Eq. 37: } PE_{BR,y} = GWP_{CH_4} \cdot EF_{CH_4,BR} \cdot \sum_n BR_{PJ,n,y} \cdot NCV_{BR,n,y}$$

Where:

$PE_{BR,y}$ = Emissions from the combustion of biomass residues during the year y (tCO₂e)
 GWP_{CH_4} = Global Warming Potential of methane valid for the commitment period (tCO₂/tCH₄)
 $EF_{CH_4,BR}$ = CH₄ emission factor for the combustion of biomass residues in the project plant (tCH₄/GJ).
 $BR_{PJ,n,y}$ = Quantity of biomass residues of category n used in the project activity in year y (tonnes on dry-basis)
 $NCV_{BR,n,y}$ = Net calorific value of biomass residue of category n in year y (GJ/tonne on dry-basis)

To determine the CH₄ emission factor ($EF_{CH_4,BR}$), project participants may conduct measurements at the plant site or use IPCC default values, as provided in Table 4 below. The uncertainty of the CH₄ emission factor is in many cases relatively high. In order to reflect this and for the purpose of providing conservative estimates of emission reductions, a conservativeness factor must be applied to the CH₄ emission factor. The level of the conservativeness factor depends on the uncertainty range of the estimate

for the CH₄ emission factor. Project participants shall select the appropriate conservativeness factor from Table 5 below and shall multiply the estimate for the CH₄ emission factor with the conservativeness factor.

For example, where the default CH₄ emission factor of 30 kg/TJ from Table 4 is used, the uncertainty is estimated to be 300%, resulting in a conservativeness factor of 1.37. Thus, in this case a CH₄ emission factor of 41.1 kg/TJ should be used.

Table 4: Default CH₄ emission factors for combustion of biomass residues¹¹

	Default emission factor (kg CH ₄ / TJ)	Assumed uncertainty
Wood waste	30	300%
Sulphite lyes (Black Liquor)	3	300%
Other solid biomass residues	30	300%
Liquid biomass residues	3	300%

Table 5: Conservativeness factors

Estimated uncertainty range (%)	Assigned uncertainty band (%)	Conservativeness factor where higher values are more conservative
Less than or equal to 10	7	1.02
Greater than 10 and less than or equal to 30	20	1.06
Greater than 30 and less than or equal to 50	40	1.12
Greater than 50 and less than or equal to 100	75	1.21
Greater than 100	150	1.37

Determination of PE_{ww,y}

This emission source should be estimated in cases where wastewater originating from the treatment of the biomass is (partly) treated under anaerobic conditions and where methane from the waste water is not captured and flared or combusted. Project emissions from waste water are estimated as follows:

¹¹ Values are based on the 2006 IPCC Guidelines, Volume 2, Chapter 2, Tables 2.2 to 2.6.

$$\text{Eq. 38: } PE_{\text{WW},y} = GWP_{\text{CH}_4} \cdot V_{\text{WW},y} \cdot \text{COD}_{\text{WW},y} \cdot B_{o,\text{WW}} \cdot \text{MCF}_{\text{WW}}$$

Where:

$PE_{\text{WW},y}$ = Emissions from wastewater generated from the treatment of biomass residues in year y (tCO₂e).

GWP_{CH_4} = Global Warming Potential of methane valid for the commitment period (tCO₂/tCH₄).

$V_{\text{WW},y}$ = Quantity of waste water generated in year y (m³).

$\text{COD}_{\text{WW},y}$ = Average chemical oxygen demand of the waste water in year y (tCOD/m³).

$B_{o,\text{WW}}$ = Methane generation potential of the waste water (tCH₄/tCOD).

MCF_{WW} = Methane correction factor for the waste water (ratio).

Leakage

The main potential source of leakage for this project activity is an increase in emissions from fossil fuel combustion or other sources due to diversion of biomass residues from other uses to the project plant as a result of the project activity. Changes in carbon stocks in the LULUCF sector are expected to be insignificant since this methodology is limited to biomass residues, as defined in the applicability conditions above. The baseline scenarios for biomass residues for which this potential leakage is relevant are B5, B6, B7 and B8.

The actual leakage emissions in each of these cases may differ significantly and depend on the specific situation of each project activity. For that reason, a simplified approach is used in this methodology: it is assumed that an equivalent amount of fossil fuels, on energy basis, would be used if biomass residues are diverted from other users, no matter what the use of biomass residues would be in the baseline scenario.

Therefore, for the categories of biomass residues whose baseline scenario has been identified as B5, B6, B7 or B8, project participants shall calculate leakage emissions as follows:

$$\text{Eq. 39: } LE_y = EF_{\text{CO}_2,\text{LE}} \cdot \sum_n BR_{\text{B5/B8},n,y} \cdot \text{NCV}_{\text{BR},n,y}$$

Where:

LE_y = Leakage emissions in year y (tCO₂).

$EF_{\text{CO}_2,\text{LE}}$ = CO₂ emission factor of the most carbon intensive fossil fuel used in the country (tCO₂/GJ).

$BR_{\text{B5/B8},n,y}$ = Quantity of biomass residues of category n used in the project activity in year y , for which the baseline scenario is B5, B6, B7 or B8 (tonnes on dry-basis)

$\text{NCV}_{\text{BR},n,y}$ = Net calorific value of biomass residue of category n in year y (GJ/tonne on dry-basis)

n = Biomass residue category.

y = Year of the crediting period.

The determination of $BR_{\text{B5/B8},n,y}$ shall be based on the monitored amounts of biomass residues used in power plants included in the project boundary.

In the case that negative overall emission reductions arise in a year through application of the leakage emissions, CERs are not issued to project participants for the year concerned and in subsequent years, until emission reductions from subsequent years have compensated the quantity of negative emission reductions from the year concerned. For example, if negative emission reductions of 30 tCO₂e occur in the year t and positive emission reductions of 100 tCO₂e occur in the year $t+1$, only 70 CERs are issued for the year $t+1$.

Data and parameters not monitored

In addition to the parameters and procedures described herein, all monitoring provisions contained in the tools referred to in this methodology also apply:

- “Tool to calculate the emission factor for an electricity system”;
- “Tool to determine methane emissions avoided from disposal of waste at a solid waste disposal site”;
- “Tool to calculate project or leakage CO₂ emissions from fossil fuel combustion”;
- “Tool to calculate baseline, project and/or leakage emissions from electricity consumption”.

Document and justify all selected values in the CDM-PDD.

The following are not monitored data and parameters:

Data / Parameter:	Biomass residues categories and quantities used for the selection of the baseline scenario selection and assessment of additionality
Data unit:	- Type (i.e. bagasse, rice husks, empty fruit bunches, etc.); - Source (e.g. produced on-site, obtained from an identified biomass residues producer, obtained from a biomass residues market, etc.); - Fate in the absence of the project activity (scenarios B); - Use in the project scenario (scenarios P); - Quantity (tonnes on dry-basis)
Description:	Explain and document transparently in the CDM-PDD, using a table similar to Table 2, which quantities of which biomass residues categories are used in which installation(s) under the project activity and what is their baseline scenario. The last column of Table 2 corresponds to the quantity of each category of biomass residues (tonnes). For the selection of the baseline scenario and demonstration of additionality, at the validation stage, an <i>ex ante</i> estimation of these quantities should be provided
Source of data:	On-site assessment of biomass residues categories and quantities
Measurement procedures (if any):	---
Any comment:	This parameter is related to the procedure for the selection of the baseline scenario selection and assessment of additionality

Data / parameter:	Data 71: BR _{HIST,n,x}
Data unit:	tonnes on dry-basis
Description:	BR _{HIST,n,x} = Quantity of biomass residues of category <i>n</i> used for power or heat generation at the project site in year <i>x</i> prior to the implementation of the project activity (tonnes on dry-basis)
Source of data:	On-site measurements
Measurement procedures (if any):	Use weight or volume meters. Adjust for the moisture content in order to determine the quantity of dry biomass. The quantity shall be cross-checked with the quantity of heat generated and any fuel purchase receipts (if available)
Any comment:	---

Data / parameter:	Data 72: $BR_{n,h,x}$
Data unit:	tonnes on dry-basis
Description:	$BR_{n,h,x}$ = Quantity of biomass residues of category n used in heat generator h in year x (tonnes on dry-basis)
Source of data:	On-site measurements
Measurement procedures (if any):	Use weight or volume meters. Adjust for the moisture content in order to determine the quantity of dry biomass. The quantity shall be cross-checked with the quantity of heat generated and any fuel purchase receipts (if available)
Any comment:	---

Data / parameter:	Data 73: $FF_{f,h,x}$
Data unit:	mass or volume unit/yr
Description:	$FF_{f,h,x}$ = Quantity of fossil fuel type f fired in heat generator h in year x (mass or volume unit/yr)
Source of data:	On-site measurements
Measurement procedures (if any):	Use weight or volume meters. Adjust for the moisture content in order to determine the quantity of dry biomass. The quantity shall be cross-checked with the quantity of heat generated and any fuel purchase receipts (if available)
Any comment:	---

Data / parameter:	Data 74: $HG_{h,x}$
Data unit:	GJ
Description:	$HG_{h,x}$ = Net quantity of heat generated in heat generator h in year x (GJ/yr)
Source of data:	On-site measurements
Measurement procedures (if any):	This parameter should be determined as the difference of the enthalpy of the process heat (steam or hot water) generated by the heat generators(s) [in the project activity, monitored during year y ,] minus the enthalpy of the feed-water, the boiler blow-down and any condensate return. The respective enthalpies should be determined based on the mass (or volume) flows, the temperatures and, in case of superheated steam, the pressure. Steam tables or appropriate thermodynamic equations may be used to calculate the enthalpy as a function of temperature and pressure.
Any comment:	---

Data / parameter:	Data 75: $HG_{BR,CG/PO,x,i,j}$
Data unit:	GJ
Description:	$HG_{BR,CG/PO,x,i,j}$ = Quantity of heat used in heat engine i/j in year x (GJ)
Source of data:	On-site measurements
Measurement procedures (if any):	This parameter should be determined as the difference of the enthalpy of the process heat (steam or hot water) generated by the heat generators(s) [in the project activity, monitored during year y ,] minus the enthalpy of the feed-water, the boiler blow-down and any condensate return. The respective enthalpies should be determined based on the mass (or volume) flows, the temperatures and, in case of superheated steam, the pressure. Steam tables or appropriate thermodynamic equations may be used to calculate the enthalpy as a function of temperature and pressure.

Any comment:	---
--------------	-----

Data / parameter:	Data 76: $HO_{BR,CG/PO,x,i/j}$
Data unit:	GJ
Description:	$HO_{BR,CG/PO,x,i/j}$ = Quantity of process heat extracted from the heat engine i/j in year x (GJ)
Source of data:	On-site measurements
Measurement procedures (if any):	This parameter should be determined as the difference of the enthalpy of the process heat (steam or hot water) supplied to process heat loads in the project activity minus the enthalpy of the feed-water, the boiler blow-down and any condensate return to the heat generators. The respective enthalpies should be determined based on the mass (or volume) flows, the temperatures and, in case of superheated steam, the pressure. Steam tables or appropriate thermodynamic equations may be used to calculate the enthalpy as a function of temperature and pressure.
Any comment:	---

Data / parameter:	Data 77: $EL_{BR,CG/PO,x,i/j}$
Data unit:	MWh
Description:	$EL_{BR,CG/PO,x,i/j}$ = Quantity of electricity generated in heat engine i/j in year x (MWh)
Source of data:	On-site measurements
Measurement procedures (if any):	Use calibrated electricity meters
Any comment:	---

Data / parameter:	Data 78: P_x
Data unit:	Use suitable units, as appropriate
Description:	P_x = Quantity of the main product of the production process (e.g. sugar cane, rice) produced in year x from plants operated at the project site
Source of data:	On-site measurements
Measurement procedures (if any):	---
Any comment:	---

Data / parameter:	Data 79: $CAP_{HG,h}$
Data unit:	GJ/h
Description:	$CAP_{HG,h}$ = Baseline capacity of heat generator h (GJ/h)
Source of data:	On-site measurements
Measurement procedures (if any):	This parameter should reflect the design maximum heat generation capacity (in GJ/h) of the baseline heat generator h . It should be based on the installed capacity of the heat generator. Project participants should document transparently and justify in the CDM-PDD how this parameter was determined.
Any comment:	---

Data / parameter:	Data 80: $CAP_{EG,CG,i}$ Data 81: $CAP_{EG,PO,i}$
--------------------------	--

Data unit:	MW
Description:	$CAP_{EG,CG,i}$ = Baseline electricity generation capacity of heat engine i (MW) $CAP_{EG,PO,j}$ = Baseline electricity generation capacity of heat engine j (MW)
Source of data:	On-site measurements
Measurement procedures (if any):	This parameter should reflect the design maximum electricity generation capacity (in MW) of the baseline heat engines i and j . It should be based on the installed capacity of the heat engines. Project participants should document transparently and justify in the CDM-PDD how this parameter was determined.
Any comment:	---

Data / parameter:	Data 82: $LFC_{HG,h}$
Data unit:	Ratio
Description:	$LFC_{HG,h}$ = Baseline load factor of heat generator h (ratio)
Source of data:	On-site measurements
Measurement procedures (if any):	This parameter should reflect the maximum load factor (i.e. the ratio between the ‘actual heat generation’ of the heat generator and its ‘design maximum heat generation’ along one year of operation) of the baseline heat generator h , taking into account downtime due to maintenance, seasonal operational patterns, and any other technical constraints. Project participants should document transparently and justify in the CDM-PDD how this parameter was determined.
Any comment:	---

Data / parameter:	Data 83: $LFC_{EG,CG,i}$ Data 84: $LFC_{EG,CG,j}$
Data unit:	Ratio
Description:	$LFC_{EG,CG,i}$ = Baseline load factor of heat engine i (ratio) $LFC_{EG,PO,j}$ = Baseline load factor of heat engine j (ratio)
Source of data:	On-site measurements
Measurement procedures (if any):	This parameter should reflect the maximum load factor (i.e. the ratio between the ‘actual electricity generation’ of the heat engine and its ‘design maximum electricity generation’ along one year of operation) of the baseline heat engine i or j . The actual electricity generation of the heat engine should be determined taking into account downtime due to maintenance, seasonal operational patterns, and any other technical constraints. Project participants should document transparently and justify in the CDM-PDD how this parameter was determined.
Any comment:	---

Data / parameter:	Data 85: $EF_{BL,CO2,FF}$
Data unit:	tCO ₂ /GJ
Description:	$EF_{BL,CO2,FF}$ = CO ₂ emission factor of the fossil fuel type that would be used for power generation at the project site in the baseline (tCO ₂ /GJ)
Source of data:	Either conduct measurements or use accurate and reliable local or national data where available. Where such data is not available, use IPCC default emission factors (country-specific, if available) if they are deemed to reasonably represent local circumstances. Choose the value in a conservative manner and justify the choice

Measurement procedures (if any):	Measurements shall be carried out at reputed laboratories and according to relevant international standards
Any comment:	In case of plants existing before project implementation, the lowest CO ₂ emission factor should be used in case of multi fuel plants

Data / parameter:	Data 86: $\eta_{BL,FF}$
Data unit:	ratio
Description:	$\eta_{BL,FF}$ = Efficiency of the fossil fuel power plant(s) at the project site in the baseline
Source of data:	Either use the higher value among (a) the measured efficiency and (b) manufacturer's information on the efficiency; OR use default values as provided in Annex 1 of the "Tool to calculate the emission factor for an electricity system"; OR assume an efficiency of 100%
Measurement procedures (if any):	If measurements are conducted, use recognized standards for the measurement of the heat generator efficiency, such as the " <i>British Standard Methods for Assessing the thermal performance of boilers for steam, hot water and high temperature heat transfer fluids</i> " (BS845). Where possible, use preferably the direct method (dividing the net heat generation by the energy content of the fuels fired during a representative time period), as it is better able to reflect average efficiencies during a representative time period compared to the indirect method (determination of fuel supply or heat generation and estimation of the losses). Document measurement procedures and results and manufacturer's information transparently in the CDM-PDD
Any comment:	---

Data / parameter:	Data 87: $NCV_{BR,n,x}$
Data unit:	GJ/tons on a dry basis
Description:	$NCV_{BR,n,x}$ = Net calorific value of biomass residues of category n in year x (GJ/mass or volume unit)
Source of data:	Either conduct measurements or use accurate and reliable local or national data where available. Where such data is not available, use IPCC default net calorific values (country-specific, if available) if they are deemed to reasonably represent local circumstances. Choose the values in a conservative manner and justify the choice
Measurement procedures (if any):	Measurements shall be carried out at reputed laboratories and according to relevant international standards
Any comment:	---

Data / parameter:	Data 88: $NCV_{FF,f,x}$
Data unit:	GJ/mass or volume unit
Description:	$NCV_{FF,f,x}$ = Net calorific value of fossil fuel type f in year x (GJ/mass or volume unit)
Source of data:	Either conduct measurements or use accurate and reliable local or national data where available. Where such data is not available, use IPCC default net calorific values (country-specific, if available) if they are deemed to reasonably represent local circumstances. Choose the values in a conservative manner and justify the choice.
Measurement	Measurements shall be carried out at reputed laboratories and according to relevant

procedures (if any):	international standards
Any comment:	---

Data / parameter:	Data 89: GWP _{CH4}
Data unit:	tCO ₂ e/tCH ₄
Description:	GWP _{CH4} = Global Warming Potential of methane valid for the commitment period (tCO ₂ /tCH ₄)
Source of data:	IPCC
Measurement procedures (if any):	21 for the first commitment period. Shall be updated according to any future COP/MOP decisions
Any comment:	---

III. MONITORING METHODOLOGY

Monitoring procedures

Describe and specify in the CDM-PDD all monitoring procedures, including the type of measurement instrumentation used, the responsibilities for monitoring and QA/QC procedures that will be applied. Where the methodology provides different options (e.g. use of default values or on-site measurements), specify which option will be used. All meters and instruments should be calibrated regularly as per industry practices.

All data collected as part of monitoring should be archived electronically and be kept at least for 2 years after the end of the last crediting period. 100% of the data should be monitored if not indicated differently in the comments in the tables below.

In addition to the parameters and procedures described herein, all monitoring provisions contained in the tools referred to in this methodology also apply:

- “Tool to calculate the emission factor for an electricity system”;
- “Tool to determine methane emissions avoided from disposal of waste at a solid waste disposal site”;
- “Tool to calculate project or leakage CO₂ emissions from fossil fuel combustion”;
- “Tool to calculate baseline, project and/or leakage emissions from electricity consumption”.

Data and parameters monitored

Data / Parameter:	Amount of fuel used in the heat generation equipment, if any
Data unit:	GJ
Description:	If any heat which is used for purposes other than power generation (e.g. heat which is produced in boilers or extracted from the header to feed thermal loads in the process) is generated during the crediting period or was generated prior to the implementation of the project activity, by any on-site or off-site heat generation equipment connected to the project site, the amount of fuel used in the heat generation equipment should be monitored and clearly differentiated from any fuel used in the project activity. The following conditions should be checked using this data:

	<ul style="list-style-type: none"> The implementation of the project activity does not influence directly or indirectly the operation of the heat generation equipment, i.e. the heat generation equipment would operate in the same manner in the absence of the project activity; and, The heat generation equipment does not influence directly or indirectly the operation of the project plant, e.g. no fuels are diverted from the heat generation equipment to the project plant.
Source of data:	On-site measurements
Measurement procedures (if any):	Use weight or volume meters. The quantity shall be cross-checked with the quantity of electricity generated and any fuel purchase receipts (if available)
Monitoring frequency:	Data monitored continuously and aggregated as appropriate, to calculate emissions reductions
QA/QC procedures:	---
Any comment:	This parameter is related to an applicability condition

Data / Parameter:	Biomass residues categories and quantities used in the project activity
Data unit:	<ul style="list-style-type: none"> Type (i.e. bagasse, rice husks, empty fruit bunches, etc.); Source (e.g. produced on-site, obtained from an identified biomass residues producer, obtained from a biomass residues market, etc.); Fate in the absence of the project activity (scenarios B); Use in the project scenario (scenarios P and H); Quantity (tonnes on dry-basis)
Description:	<p>Explain and document transparently in the CDM-PDD, using a table similar to Table 2, which quantities of which biomass residues categories are used in which installation(s) under the project activity and what is their baseline scenario.</p> <p>The last column of Table 2 corresponds to the quantity of each category of biomass residues (tonnes on dry-basis). These quantities should be updated every year of the crediting period as part of the monitoring plan so as to reflect the actual use of biomass residues in the project scenario. These updated values should be used for emissions reductions calculations.</p> <p>Along the crediting period, new categories of biomass residues (i.e. new types, new sources, with different fate) can be used in the project activity. In this case, a new line should be added to the table. If those new categories are of the type B1, B2 or B3, the baseline scenario for those types of biomass residues should be assessed using the procedures outlined in the guidance provided in the procedure for the selection of the baseline scenario and demonstration of additionality</p>
Source of data:	On-site measurements
Measurement procedures (if any):	Use weight meters. Adjust for the moisture content in order to determine the quantity of dry biomass
Monitoring frequency:	Data monitored continuously and aggregated as appropriate, to calculate emissions reductions
QA/QC procedures:	Crosscheck the measurements with an annual energy balance that is based on purchased quantities and stock changes
Any comment:	---

Data / parameter:	For biomass residues categories for which scenarios B1, B2 or B3 is deemed a
--------------------------	--

	plausible baseline alternative, project participants shall demonstrate that this is a realistic and credible alternative scenario
Data unit:	tonnes
Description:	<ul style="list-style-type: none"> - Quantity of available biomass residues of type n in the region - Quantity of biomass residues of type n that are utilized (e.g. for energy generation or as feedstock) in the defined geographical region - Availability of a surplus of biomass residues type n (which can not be sold or utilized) at the ultimate supplier to the project and a representative sample of other suppliers in the defined geographical region
Source of data:	Surveys or statistics
Measurement procedures (if any):	---
Monitoring frequency:	At the validation stage for biomass residues categories identified <i>ex-ante</i> , and always that new biomass residues categories are included during the crediting period
QA/QC procedures:	---
Any comment:	---

Data / Parameter:	Data 44: $BR_{PJ,n,y}$
Data unit:	tonnes on dry-basis
Description:	$BR_{PJ,n,y}$ = Quantity of biomass residues of category <i>n</i> used in the project activity in year <i>y</i> (tonnes on dry-basis)
Source of data:	On-site measurements
Measurement procedures (if any):	Use weight meters. Adjust for the moisture content in order to determine the quantity of dry biomass
Monitoring frequency:	Data monitored continuously and aggregated as appropriate, to calculate emissions reductions
QA/QC procedures:	Crosscheck the measurements with an annual energy balance that is based on purchased quantities and stock changes
Any comment:	The biomass residue quantities used should be monitored separately for (a) each type of biomass residue (e.g.) and each source (e.g. produced on-site, obtained from biomass residues suppliers, obtained from a biomass residues market, obtained from an identified biomass residues producer, etc.)

Data / Parameter:	Data 45: $BR_{B4,n,y}$
Data unit:	tonnes on dry-basis
Description:	$BR_{B4,n,y}$ = Quantity of biomass residues of category <i>n</i> used in the project activity in year <i>y</i> for which the baseline scenario is B4 (tonne on dry-basis)
Source of data:	On-site measurements
Measurement procedures (if any):	Use weight meters. Adjust for the moisture content in order to determine the quantity of dry biomass
Monitoring frequency:	Data monitored continuously and aggregated as appropriate, to calculate emissions reductions
QA/QC procedures:	Crosscheck the measurements with an annual energy balance that is based on purchased quantities and stock changes
Any comment:	The procedures in Step 1.5 on page 23 should also be followed

Data / Parameter:	Data 46: $BR_{B1/B3,n,y}$
Data unit:	tonnes on dry-basis
Description:	$BR_{B1/B3,n,y}$ = Quantity of biomass residues of category n used in the project activity in year y for which the baseline scenario is B1 or B3 (tonnes on dry-basis)
Source of data:	On-site measurements
Measurement procedures (if any):	Use weight meters. Adjust for the moisture content in order to determine the quantity of dry biomass
Monitoring frequency:	Data monitored continuously and aggregated as appropriate, to calculate emissions reductions
QA/QC procedures:	Crosscheck the measurements with an annual energy balance that is based on purchased quantities and stock changes
Any comment:	---

Data / Parameter:	Data 47: $BR_{B5/B8,n,y}$
Data unit:	tonnes on dry-basis
Description:	$BR_{B5/B8,n,y}$ = Quantity of biomass residues of category n used in the project activity in year y , for which the baseline scenario is B5, B6, B7 or B8 (tonnes on dry-basis)
Source of data:	On-site measurements
Measurement procedures (if any):	Use weight meters. Adjust for the moisture content in order to determine the quantity of dry biomass
Monitoring frequency:	Data monitored continuously and aggregated as appropriate, to calculate emissions reductions
QA/QC procedures:	Crosscheck the measurements with an annual energy balance that is based on purchased quantities and stock changes
Any comment:	---

Data / Parameter:	Data 48: $BR_{TR,y}$
Data unit:	tonnes on dry-basis
Description:	$BR_{TR,y}$ = Quantity of biomass residues that has been transported to the project site during the year y (tonnes of dry matter)
Source of data:	On-site measurements
Measurement procedures (if any):	Use weight or volume meters. If volume meters are used convert to mass units using the density of each category of biomass residues. Adjust for the moisture content in order to determine the quantity of dry biomass
Monitoring frequency:	Data monitored continuously and aggregated as appropriate, to calculate emissions reductions
QA/QC procedures:	Crosscheck the measurements with an annual energy balance that is based on purchased quantities and stock changes
Any comment:	---

Data / parameter:	Data 49: $FC_{TR,f,y}$
Data unit:	Mass or volume unit
Description:	$FC_{TR,f,y}$ = Fuel consumption of fuel type f in trucks for transportation of biomass

	residues during the year y (mass or volume unit)
Source of data:	Fuel purchase receipts or fuel consumptions meters in the trucks
Measurement procedures (if any):	---
Monitoring frequency:	Data monitored continuously and aggregated as appropriate, to calculate emissions reductions
QA/QC procedures:	Cross-checked the resulting CO ₂ emissions for plausibility with a simple calculation based on the distance approach (option 1).
Any comment:	Applicable if option 2 is chosen to estimate CO ₂ emissions from transportation

Data / Parameter:	Data 50: $EF_{km,y}$
Data unit:	tCO ₂ /km
Description:	$EF_{km,y}$ = Average CO ₂ emission factor for the trucks measured during the year y (tCO ₂ /km)
Source of data:	Conduct sample measurements of the fuel type, fuel consumption and distance traveled for all truck types. Calculate CO ₂ emissions from fuel consumption by multiplying with appropriate net calorific values and CO ₂ emission factors. For net calorific values and CO ₂ emission factors, use reliable national default values or, if not available, (country-specific) IPCC default values. Alternatively, choose emission factors applicable for the truck types used from the literature in a conservative manner (i.e. the higher end within a plausible range)
Measurement procedures (if any):	---
Monitoring frequency:	At least annually
QA/QC procedures:	Cross-check measurement results with emission factors referred to in the literature
Any comment:	---

Data / Parameter:	Data 51: $EF_{BR,n,y}$
Data unit:	tCH ₄ /GJ
Description:	$EF_{BR,n,y}$ = CH ₄ emission factor for uncontrolled burning of the biomass residues category n during the year y (tCH ₄ /GJ)
Source of data:	Conduct measurements or use reference default values
Measurement procedures (if any):	To determine the CH ₄ emission factor, project participants may undertake measurements or use referenced default values. In the absence of more accurate information, it is recommended to use 0.0027 t CH ₄ per ton of biomass as default value for the product of NCV_k and $EF_{burning,CH_4,k,y}$
Monitoring frequency:	---
QA/QC procedures:	---
Any comment:	---

Data / Parameter:	Data 52: $EF_{FF,f,y}$
Data unit:	tCO ₂ /GJ
Description:	$EF_{FF,f,y}$ = CO ₂ emission factor for fossil fuel type f in year y (tCO ₂ /GJ)
Source of data:	Either conduct measurements or use accurate and reliable local or national data where available. Where such data is not available, use IPCC default emission

	factors (country-specific, if available) if they are deemed to reasonably represent local circumstances. Choose the value in a conservative manner and justify the choice
Measurement procedures (if any):	Measurements shall be carried out at reputed laboratories and according to relevant international standards
Monitoring frequency:	In case of measurements: At least every six months, taking at least three samples for each measurement In case of other data sources: Review the appropriateness of the data annually
QA/QC procedures:	Check consistency of measurements and local/national data with default values by the IPCC. If the values differ significantly from IPCC default values, possibly collect additional information or conduct measurements
Any comment:	---

Data / parameter:	Data 53: $EF_{CH_4, BR}$
Data unit:	tCH ₄ /GJ
Description:	$EF_{CH_4, BR}$ = CH ₄ emission factor for the combustion of biomass residues in the project plant (tCH ₄ /GJ)
Source of data:	On-site measurements or default values, as provided in Table 4
Measurement procedures (if any):	The CH ₄ emission factor may be determined based on a stack gas analysis using calibrated analyzers
Monitoring frequency:	At least quarterly, taking at least three samples per measurement
QA/QC procedures:	Check the consistency of the measurements by comparing the measurement results with measurements from previous years, relevant data sources (e.g. values in the literature, values used in the national GHG inventory) and default values by the IPCC. If the measurement results differ significantly from previous measurements or other relevant data sources, conduct additional measurements
Any comment:	Monitoring of this parameter for project emissions is only required if CH ₄ emissions from biomass combustion are included in the project boundary. Note that a conservative factor shall be applied, as specified in the baseline methodology

Data / parameter:	Data 54: $EF_{CO_2, LE}$
Data unit:	tCO ₂ /GJ
Description:	$EF_{CO_2, LE}$ = CO ₂ emission factor of the most carbon intensive fossil fuel used in the country (tCO ₂ /GJ)
Source of data:	Identify the most carbon intensive fuel type from the national communication, other literature sources (e.g. IEA). Possibly consult with the national agency responsible for the national communication / GHG inventory. If available, use national default values for the CO ₂ emission factor. Otherwise, IPCC default values may be used
Measurement procedures (if any):	---
Monitoring frequency:	Annually
QA/QC procedures:	---
Any comment:	---

Data / Parameter:	Data 55: $HO_{BL,y}$
Data unit:	GJ
Description:	$HO_{BL,y}$ = Baseline process heat generation in year y (GJ)
Source of data:	On-site measurements
Measurement procedures (if any):	This parameter should be determined as the difference of the enthalpy of the process heat (steam or hot water) supplied to process heat loads in the project activity minus the enthalpy of the feed-water, the boiler blow-down and any condensate return of the heat generators. The respective enthalpies should be determined based on the mass (or volume) flows, the temperatures and, in case of superheated steam, the pressure. Steam tables or appropriate thermodynamic equations may be used to calculate the enthalpy as a function of temperature and pressure.
Monitoring frequency:	Data monitored continuously and aggregated as appropriate, to calculate emissions reductions
QA/QC procedures:	---
Any comment:	---

Data / Parameter:	Data 56: $EL_{PJ,gross,y}$
Data unit:	MWh
Description:	$EL_{PJ,gross,y}$ = Gross quantity of electricity generated in all power plants which are located at the project site and included in the project boundary in year y (MWh)
Source of data:	On-site measurements
Measurement procedures (if any):	Use calibrated electricity meters
Monitoring frequency:	Data monitored continuously and aggregated as appropriate, to calculate emissions reductions
QA/QC procedures:	The consistency of metered electricity generation should be cross-checked with receipts from electricity sales (if available) and the quantity of fuels fired (e.g. check whether the electricity generation divided by the quantity of fuels fired results in a reasonable efficiency that is comparable to previous years).
Any comment:	---

Data / Parameter:	Data 57: $EL_{PJ,imp,y}$
Data unit:	MWh
Description:	$EL_{PJ,imp,y}$ = Project electricity imports from the grid in year y (MWh)
Source of data:	On-site measurements
Measurement procedures (if any):	Use calibrated electricity meters
Monitoring frequency:	Data monitored continuously and aggregated as appropriate, to calculate emissions reductions
QA/QC procedures:	The consistency of metered electricity generation should be cross-checked with receipts from electricity purchases
Any comment:	---

Data / Parameter:	Data 58: $EL_{PJ,aux,y}$
Data unit:	MWh

Description:	$EL_{PJ,aux,y}$ = Total auxiliary electricity consumption required for the operation of the power plants at the project site in year y (MWh)
Source of data:	On-site measurements
Measurement procedures (if any):	Use calibrated electricity meters
Monitoring frequency:	Data monitored continuously and aggregated as appropriate, to calculate emissions reductions
QA/QC procedures:	The consistency of metered electricity generation should be cross-checked with receipts from electricity sales (if available) and the quantity of fuels fired (e.g. check whether the electricity generation divided by the quantity of fuels fired results in a reasonable efficiency that is comparable to previous years).
Any comment:	$EG_{PJ,aux,y}$ shall include all electricity required for the operation of equipment related to the preparation, storage and transport of biomass residues (e.g. for mechanical treatment of the biomass, conveyor belts, driers, etc.) and electricity required for the operation of all power plants which are located at the project site and included in the project boundary (e.g. for pumps, fans, cooling towers, instrumentation and control, etc.)

Data / Parameter:	Data 59: $NCV_{BR,n,y}$
Data unit:	GJ/tonnes on dry-basis
Description:	$NCV_{BR,n,y}$ = Net calorific value of biomass residue of category n in year y (GJ/tonne on dry-basis)
Source of data:	On-site measurements
Measurement procedures (if any):	Measurements shall be carried out at reputed laboratories and according to relevant international standards. Measure the NCV on dry-basis
Monitoring frequency:	At least every six months, taking at least three samples for each measurement.
QA/QC procedures:	Check the consistency of the measurements by comparing the measurement results with measurements from previous years, relevant data sources (e.g. values in the literature, values used in the national GHG inventory) and default values by the IPCC. If the measurement results differ significantly from previous measurements or other relevant data sources, conduct additional measurements. Ensure that the NCV is determined on the basis of dry biomass
Any comment:	---

Data / Parameter:	Data 60 : $NCV_{FF,f,y}$
Data unit:	GJ/mass or volume unit
Description:	$NCV_{FF,f,y}$ = Net calorific value of fossil fuel type f in year y (GJ/mass or volume unit)
Source of data:	Either conduct measurements or use accurate and reliable local or national data where available. Where such data is not available, use IPCC default net calorific values (country-specific, if available) if they are deemed to reasonably represent local circumstances. Choose the values in a conservative manner and justify the choice
Measurement procedures (if any):	Measurements shall be carried out at reputed laboratories and according to relevant international standards
Monitoring frequency:	In case of measurements: At least every six months, taking at least three samples for each measurement

	In case of other data sources: Review the appropriateness of the data annually
QA/QC procedures:	Check consistency of measurements and local/national data with default values by the IPCC. If the values differ significantly from IPCC default values, possibly collect additional information or conduct measurements
Any comment:	

Data / Parameter:	Data 61: $h_{LOW,y}$ Data 62: $h_{HIGH,y}$
Data unit:	GJ/tonnes
Description:	$h_{LOW,y}$ = Energy content of the heat carrier at the process heat demand side (GJ/tonnes) (enthalpy of steam in case of steam systems) $h_{HIGH,y}$ = Energy content of the heat carrier at the heat generator side (GJ/tonnes) (enthalpy of steam in case of steam systems)
Source of data:	On-site measurements
Measurement procedures (if any):	The specific enthalpies should be determined based on the temperatures and, in case of superheated steam, the pressure. Steam tables or appropriate thermodynamic equations may be used to calculate the enthalpy as a function of temperature and pressure.
Monitoring frequency:	Data monitored continuously and aggregated as appropriate, to calculate emissions reductions
QA/QC procedures:	---
Any comment:	---

Data / parameter:	Moisture content of the biomass residues
Data unit:	% Water content
Description:	Moisture content of each biomass residues type k
Source of data:	On-site measurements
Measurement procedures (if any):	---
Monitoring frequency:	The moisture content should be monitored for each batch of biomass of homogeneous quality. The weighted average should be calculated for each monitoring period and used in the calculations
QA/QC procedures:	---
Any comment:	In case of dry biomass, monitoring of this parameter is not necessary

Data / Parameter:	Data 63: P_y
Data unit:	Use suitable units, as appropriate
Description:	P_y = Quantity of the main product of the production process (e.g. sugar cane, rice) produced in year y from plants operated at the project site
Source of data:	On-site measurements
Measurement procedures (if any):	---
Monitoring frequency:	Data aggregated as appropriate, to calculate emissions reductions
QA/QC procedures:	---
Any comment:	---

Data / Parameter:	Data 64: N_y
Data unit:	---
Description:	N_y = Number of truck trips for the transportation of biomass during the year y
Source of data:	On-site measurements
Measurement procedures (if any):	---
Monitoring frequency:	Data monitored continuously and aggregated as appropriate, to calculate emissions reductions
QA/QC procedures:	Check consistency of the number of truck trips with the quantity of biomass combusted, e.g. by the relation with previous years
Any comment:	---

Data / Parameter:	Data 65: AVD_y
Data unit:	km
Description:	AVD_y = Average round trip distance (from and to) between the biomass residues fuel supply sites and the site of the project plant during the year y (km)
Source of data:	Records by project participants on the origin of the biomass
Measurement procedures (if any):	---
Monitoring frequency:	Data monitored continuously and aggregated as appropriate, to calculate emissions reductions
QA/QC procedures:	Check consistency of distance records provided by the truckers by comparing recorded distances with other information from other sources (e.g. maps).
Any comment:	Applicable if option 1 is chosen to estimate CO ₂ emissions from transportation. If biomass is supplied from different sites, this parameter should correspond to the mean value of km traveled by trucks that supply the biomass plant

Data / Parameter:	Data 66: TL_y
Data unit:	tonnes
Description:	TL_y = Average truck load of the trucks used during the year y (tonnes)
Source of data:	On-site measurements
Measurement procedures (if any):	Determined by averaging the weights of each truck carrying biomass to the project plant
Monitoring frequency:	Data monitored continuously and aggregated as appropriate, to calculate emissions reductions
QA/QC procedures:	---
Any comment:	---

Data / parameter:	Data 67: $V_{ww,y}$
Data unit:	m ³
Description:	$V_{ww,y}$ = Quantity of waste water generated in year y (m ³)
Source of data:	On-site measurements
Measurement procedures (if any):	---
Monitoring frequency:	Data monitored continuously and aggregated as appropriate, to calculate emissions reductions

QA/QC procedures:	---
Any comment:	---

Data / parameter:	Data 68: COD _{WW,y}
Data unit:	tCOD/m ³
Description:	COD _{WW,y} = Average chemical oxygen demand of the waste water in year y (tCOD/m ³)
Source of data:	On-site measurements
Measurement procedures (if any):	---
Monitoring frequency:	---
QA/QC procedures:	---
Any comment:	---

Data / parameter:	Data 69: B _{o,WW}
Data unit:	tCH ₄ /tCOD
Description:	B _{o,WW} = Methane generation potential of the waste water (tCH ₄ /tCOD)
Source of data:	On-site measurements or reference default values
Measurement procedures (if any):	---
Monitoring frequency:	---
QA/QC procedures:	---
Any comment:	---

Data / parameter:	Data 70: MCF _{WW}
Data unit:	ratio
Description:	MCF _{WW} = Methane correction factor for the waste water (ratio)
Source of data:	On-site measurements or reference default values
Measurement procedures (if any):	---
Monitoring frequency:	---
QA/QC procedures:	---
Any comment:	---

IV. REFERENCES AND ANY OTHER INFORMATION

Not applicable.

Annex 1: Definition of data used in the methodology

Data <Number>: <Name> <Units>	Cross-references in the methodology
Data 1: ER_y = Emissions reductions in year y (tCO ₂)	Calculated in Eq. 1 on page 18
Data 2: BE_y = Baseline emissions in year y (tCO ₂)	Calculated in Eq. 2 on page 20
Data 3: $EL_{BL,y}$ = Baseline electricity generation in year y (MWh)	Calculated in Eq. 3 on page 22
Data 4: $CAP_{HG,total}$ = Baseline heat generation capacity (GJ)	Calculated in Eq. 4 on page 22
Data 5: $CAP_{EG,total}$ = Baseline electricity generation capacity (MWh)	Calculated in Eq. 5 on page 23
Data 6: $EL_{BL,GR,y}$ = Baseline minimum electricity generation in the grid in year y (MWh)	Calculated in Eq. 6 on page 25
Data 7: $HG_{BL,BR,y}$ = Baseline biomass-based heat generation in year y (GJ)	Calculated in Eq. 7 on page 26.
Data 8: $BR_{B4,n,h,y}$ = Quantity of biomass residues of category n used in heat generator h in year y with baseline scenario B4 (tonne on dry-basis)	Calculated in Eq. 8 on page 26
Data 9: $EL_{BL,BR,CG,y}$ = Baseline biomass-based co-generated electricity in year y (MWh)	Calculated in Eq. 10 on page 28
Data 10: $HO_{BL,BR,CG,y}$ = Baseline biomass-based process heat co-generated in year y (GJ)	Calculated in Eq. 11 on page 28
Data 11: $HG_{BL,BR,CG,y,i}$ = Baseline biomass-based heat used in heat engine i in year y (GJ)	Calculated in Eq. 12 on page 28
Data 12: $EL_{BL,BR,PO,y}$ = Baseline biomass-based electricity (power-only) in year y (MWh)	Calculated in Eq. 15 on page 31
Data 13: $HG_{BL,BR,PO,y,j}$ = Baseline biomass-based heat used in heat engine j in year y (GJ)	Calculated in Eq. 16 on page 31
Data 14: $HG_{BL,FF,y,h}$ = Baseline fossil-based heat generation in heat generator h in year y (GJ)	Calculated in Eq. 19 on page 33
Data 15: $EL_{BL,FF,y}$ = Baseline fossil-based electricity generation in year y (MWh)	Calculated in Eq. 21 on page 34
Data 16: $HG_{BL,FF,y,i}$ = Baseline fossil-based heat used in heat engine i in year y (GJ)	Calculated in Eq. 22 on page 35
Data 17: $HG_{BR,h,x}$ = Net quantity of heat generated from using biomass residues in heat generator h in year x (MWh/yr)	Calculated in Eq. 26 on page 38
Data 18: $HG_{FF,h,x}$ = Net quantity of heat generated from using fossil fuels in heat generator h in year x (MWh/yr)	Calculated in Eq. 26 on page 38
Data 19: $HPR_{BL,i}$ = Baseline heat-to-power ratio of the heat engine i (ratio)	Calculated in Eq. 28 on page 39
Data 20: $BE_{BR,y}$ = Baseline emissions due to disposal of biomass residues in year y (tCO ₂ e)	Calculated in Eq. 29 on page 39

Data 21: $BE_{BR,B1/B3,y}$ = Baseline emissions due to aerobic decay or uncontrolled burning of biomass residues in year y (tCO ₂)	Calculated in Eq. 30 on page 40
Data 22: PE_v = Project emissions in year y (tCO ₂)	Calculated in Eq. 31 on page 42
Data 23: $PE_{GR1,y}$ = Emissions during the year y due to grid electricity imports to the project site (tCO ₂)	Calculated in Eq. 32 on page 43
Data 24: $PE_{GR2,y}$ = Emissions due to a reduction in electricity generation at the project site as compared to the baseline scenario in year y (tCO ₂)	Calculated in Eq. 33 on page 43
Data 25: $PE_{TR,y}$ = Emissions during the year y due to transport of the biomass residues to the project plant (tCO ₂)	Calculated in Eq. 34, Eq. 35, or Eq. 36 on page 43
Data 26: $PE_{BR,y}$ = Emissions from the combustion of biomass residues during the year y (tCO ₂ e)	Calculated in Eq. 37 on page 44
Data 27: $PE_{WW,y}$ = Emissions from wastewater generated from the treatment of biomass residues in year y (tCO ₂ e)	Calculated in Eq. 38 on page 46
Data 28: LE_v = Leakage emissions in year y (tCO ₂)	Calculated in Eq. 39 on page 46
Data 29: $EF_{EG,FF,y}$ = CO ₂ emission factor for electricity generation with fossil fuels at the project site in the baseline in year y (tCO ₂ /MWh)	Calculated in Step 5 on page 35
Data 30: $\eta_{BL,EG,CG,i}$ = Baseline electricity generation efficiency of heat engine i (MWh/GJ)	Calculated in Step 6 on page 36
Data 31: $\eta_{BL,EG,PO,j}$ = Average electric power generation efficiency of heat engine j (MWh/GJ)	Calculated in Step 6 on page 36
Data 32: $\eta_{BL,HG,FF,h}$ = Baseline fossil-based heat generation efficiency of heat generator h (ratio)	Calculated in Step 6 on page 36
Data 33: $\eta_{BL,HG,BR,h}$ = Baseline biomass-based heat generation efficiency of heat generator h (ratio)	Calculated in Step 6 on page 36
Data 34: $FF_{BL,HG,y,f}$ = Baseline fossil fuel demand for process heat in year y (GJ)	Calculated along the several steps in the Baseline Emissions section, depending on the balances of heat and electricity
Data 35: $EL_{BL,FF/GR,y}$ = Baseline uncertain electricity generation in the grid or on-site in year y (MWh)	Calculated along the several steps in the Baseline Emissions section, depending on the balances of heat and electricity
Data 36: $HG_{balance,BR,PO,y}$ = Baseline biomass-based heat balance after cogeneration in year y (GJ)	Calculated along the several steps in the Baseline Emissions section, depending on the balances of heat and electricity
Data 37: $EL_{balance,PO,y}$ = Baseline electricity generation after cogeneration in year y (MWh)	Calculated along the several steps in the Baseline Emissions section, depending on the balances of heat and electricity
Data 38: $HO_{balance,FF,y}$ = Balance of process heat demand after cogeneration in year y (GJ)	Calculated along the several steps in the Baseline Emissions section, depending on the balances of heat and electricity
Data 39: $EL_{balance,FF,y}$ = Baseline electricity balance after biomass-based generation in year y (MWh)	Calculated along the several steps in the Baseline Emissions section, depending on the balances of heat and electricity

Data 40: $EL_{PJ,offset,y}$ = Electricity that would be generated in the baseline that exceeds the generation of electricity during year y (MWh)	Calculated along the several steps in the Baseline Emissions section, depending on the balances of heat and electricity
Data 41: $EF_{EG,GR,y}$ = Grid emission factor in year y (tCO_2/MWh)	Calculated in Step 5 on page 35 using the “Tool to calculate the emission factor for an electricity system”
Data 42: $BE_{BR,B2,y}$ = Baseline emissions due to anaerobic decay of biomass residues in year y (tCO_2)	Calculated in Step 7.2 on page 41 using the “Tool to determine methane emissions avoided from disposal of waste at a solid waste disposal site”
Data 43: $PE_{FF,y}$ = Emissions during the year y due to fossil fuel consumption at the project site (tCO_2)	Calculated using the “Tool to calculate project or leakage CO_2 emissions from fossil fuel combustion”
Data 44: $BR_{PJ,n,y}$ = Quantity of biomass residues of category n used in the project activity in year y (tonnes on dry-basis)	Monitored
Data 45: $BR_{B4,n,y}$ = Quantity of biomass residues of category n used in the project activity in year y for which the baseline scenario is B4 (tonne on dry-basis)	Monitored
Data 46: $BR_{B1/B3,n,y}$ = Quantity of biomass residues of category n used in the project activity in year y for which the baseline scenario is B1 or B3 (tonnes on dry-basis)	Monitored
Data 47: $BR_{B5/B8,n,y}$ = Quantity of biomass residues of category n used in the project activity in year y , for which the baseline scenario is B5, B6, B7 or B8 (tonnes on dry-basis)	Monitored
Data 48: $BR_{TR,y}$ = Quantity of biomass residues that has been transported to the project site during the year y (tonnes of dry matter)	Monitored
Data 49: $FC_{TR,f,y}$ = Fuel consumption of fuel type f in trucks for transportation of biomass residues during the year y (mass or volume unit)	Monitored
Data 50: $EF_{km,y}$ = Average CO_2 emission factor for the trucks measured during the year y (tCO_2/km)	Monitored
Data 51: $EF_{BR,n,y}$ = CH_4 emission factor for uncontrolled burning of the biomass residues category n during the year y (tCH_4/GJ)	Monitored
Data 52: $EF_{FF,f,y}$ = CO_2 emission factor for fossil fuel type f in year y (tCO_2/GJ)	Monitored
Data 53: $EF_{CH_4,BR}$ = CH_4 emission factor for the combustion of biomass residues in the project plant (tCH_4/GJ)	Monitored
Data 54: $EF_{CO_2,LE}$ = CO_2 emission factor of the most carbon intensive fossil fuel used in the country (tCO_2/GJ)	Monitored
Data 55: $HO_{BL,y}$ = Baseline process heat generation in year y (GJ)	Monitored
Data 56: $EL_{PJ,gross,y}$ = Gross quantity of electricity	Monitored

generated in all power plants which are located at the project site and included in the project boundary in year y (MWh)	
Data 57: $EL_{PJ,imp,y}$ = Project electricity imports from the grid in year y (MWh)	Monitored
Data 58: $EL_{PJ,aux,y}$ = Total auxiliary electricity consumption required for the operation of the power plants at the project site in year y (MWh)	Monitored
Data 59: $NCV_{BR,n,y}$ = Net calorific value of biomass residue of category n in year y (GJ/tonne on dry-basis)	Monitored
Data 60: $NCV_{FF,f,y}$ = Net calorific value of fossil fuel type f in year y (GJ/mass or volume unit)	Monitored
Data 61: $h_{LOW,y}$ = Energy content of the heat carrier at the process heat demand side (GJ/tonnes) (enthalpy of steam in case of steam systems)	Monitored
Data 62: $h_{HIGH,y}$ = Energy content of the heat carrier at the heat generator side (GJ/tonnes) (enthalpy of steam in case of steam systems)	Monitored
Data 63: P_y = Quantity of the main product of the production process (e.g. sugar cane, rice) produced in year y from plants operated at the project site	Monitored
Data 64: N_y = Number of truck trips for the transportation of biomass during the year y	Monitored
Data 65: AVD_y = Average round trip distance (from and to) between the biomass residues fuel supply sites and the site of the project plant during the year y (km)	Monitored
Data 66: TL_y = Average truck load of the trucks used during the year y (tonnes)	Monitored
Data 67: $V_{WW,y}$ = Quantity of waste water generated in year y (m ³)	Monitored
Data 68: $COD_{WW,y}$ = Average chemical oxygen demand of the waste water in year y (tCOD/m ³)	Monitored
Data 69: $B_{o,WW}$ = Methane generation potential of the waste water (tCH ₄ /tCOD)	Monitored
Data 70: MCF_{WW} = Methane correction factor for the waste water (ratio)	Monitored
Data 71: $BR_{HIST,n,x}$ = Quantity of biomass residues of category n used for power or heat generation at the project site in year x prior to the implementation of the project activity (tonnes on dry-basis)	Not monitored
Data 72: $BR_{n,h,x}$ = Quantity of biomass residues of category n used in heat generator h in year x (tonnes on dry-basis)	Not monitored
Data 73: $FF_{f,h,x}$ = Quantity of fossil fuel type f fired in heat generator h in year x (mass or volume	Not monitored

unit/yr)	
Data 74: $HG_{h,x}$ = Net quantity of heat generated in heat generator h in year x (GJ/yr)	Not monitored
Data 75: $HG_{BR,CG/PO,x,i/j}$ = Quantity of heat used in heat engine i/j in year x (GJ)	Not monitored
Data 76: $HO_{BR,CG/PO,x,i/j}$ = Quantity of process heat extracted from the heat engine i/j in year x (GJ)	Not monitored
Data 77: $EL_{BR,CG/PO,x,i/j}$ = Quantity of electricity generated in heat engine i/j in year x (MWh)	Not monitored
Data 78: P_x = Quantity of the main product of the production process (e.g. sugar cane, rice) produced in year x from plants operated at the project site	Not monitored
Data 79: $CAP_{HG,h}$ = Baseline capacity of heat generator h (GJ/h)	Not monitored
Data 80: $CAP_{EG,CG,i}$ = Baseline electricity generation capacity of heat engine i (MW)	Not monitored
Data 81: $CAP_{EG,PO,j}$ = Baseline electricity generation capacity of heat engine j (MW)	Not monitored
Data 82: $LFC_{HG,h}$ = Baseline load factor of heat generator h (ratio)	Not monitored
Data 83: $LFC_{EG,CG,i}$ = Baseline load factor of heat engine i (ratio)	Not monitored
Data 84: $LFC_{EG,PO,j}$ = Baseline load factor of heat engine j (ratio)	Not monitored
Data 85: $EF_{BL,CO_2,FF}$ = CO ₂ emission factor of the fossil fuel type that would be used for power generation at the project site in the baseline (tCO ₂ /GJ)	Not monitored
Data 86: $\eta_{BL,FF}$ = Efficiency of the fossil fuel power plant(s) at the project site in the baseline	Not monitored
Data 87: $NCV_{BR,n,x}$ = Net calorific value of biomass residues of category n in year x (GJ/mass or volume unit)	Not monitored
Data 88: $NCV_{FF,f,x}$ = Net calorific value of fossil fuel type f in year x (GJ/mass or volume unit)	Not monitored
Data 89: GWP_{CH_4} = Global Warming Potential of methane valid for the commitment period (tCO ₂ /tCH ₄)	Not monitored
Index 1: y = Year of the crediting period	-
Index 2: h = Heat generator in the baseline scenario	-
Index 3: i = Cogeneration-type heat engine in the baseline scenario	-
Index 4: j = Power-only-type heat engine in the baseline scenario	-
Index 5: f = Fossil fuel type	-
Index 6: x = Last calendar year prior to the start of the crediting period	-

Index 7: n = Biomass residue category	-
---------------------------------------	---

History of the Document

Version	Date	Nature of Revision
01	EB XX, Annex XX DD MMMM 2010	To be considered at EB XX.